

Miniature Telephone Line Interface Module for CTI Applications

Description

The XE0055CS2 is an extremely compact, high-performance telephone interface module. The XE0055CS2 meets the technical requirements for V.34bis operation yet fills less than one quarter cubic inch of space. The XE0055CS2 complies with FCC Part 68 Rules simplifying certification of the completed system.

The XE0055CS2 is a low power design operating from a single +5 volt power supply. As with all Xecom telephone interface modules, internal ring indication and switch hook are provided to establish the telephone line connection.

The XE0055CS2 also includes advanced features for Computer Telephone Integration (CTI) applications. The XE0055CS2 incorporates Caller ID access and a continuous Connect Detect monitor. Connect Detect reports the current availability of the local telephone line. With these features the host can screen incoming calls and initiate outgoing calls only when the line is available.

Features

- * Small Size: 2.0" long by 0.5" wide by 0.27" thick;
- * V.34bis compatible for data transfer at speeds up to 33,600 bps;
- * FCC Part 68 Compliant;
- * Integrated Ring Detect Circuit;
- * Provides an on-hook signal path for monitoring the Caller ID Signal
- * Integrated Connect Detect circuit continually monitors the availability of the local telephone line
- * Single 5 Volt Power Supply
- * Integrated Solid-State Switch Hook
- * Provides a 1500 volt isolation barrier between the Telephone Line and all other circuits

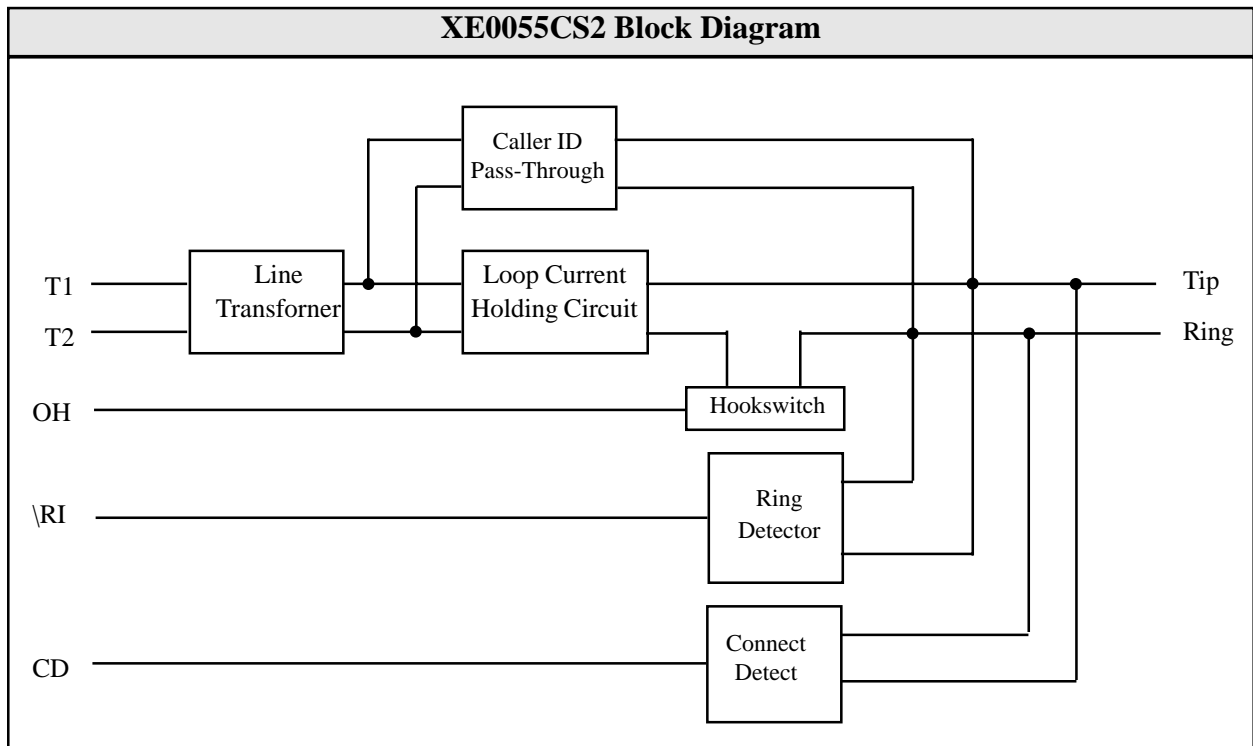

XE0055CS2 Mechanical Specifications

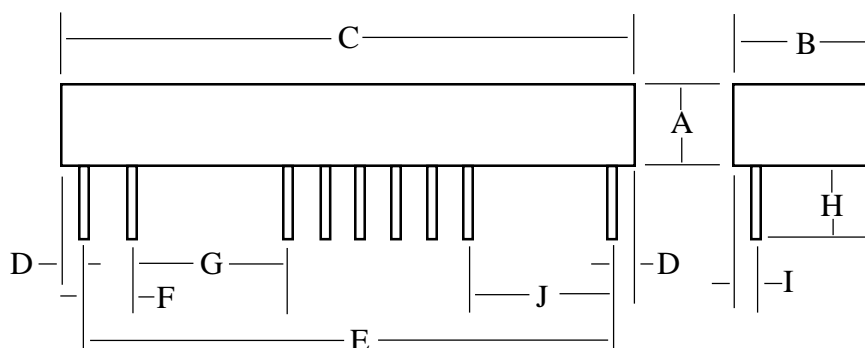

Dim	Inches		Millimeters	
	Min	Max	Min	Max
A	0.290	0.310	7.37	7.87
B	0.490	0.510	12.45	12.95
C	1.990	2.010	50.55	51.05
D	0.040	0.060	1.02	1.52
E	1.390	1.410	35.31	35.81
F	0.090	0.110	2.29	2.79
G	0.790	0.810	20.07	20.57
H	0.125	0.200	3.18	5.08
I	0.022	0.028	0.56	0.71
J	0.490	0.510	12.45	12.95

Pin Size: 0.025" by 0.025"
Recommended hole size: 0.056"

ABSOLUTE MAXIMUM RATINGS

Storage Temperature	-25°C to +85°C
Operating Temperature Range	0°C to +70°C
Maximum Lead Temperature (soldering 2 seconds per wave)	260°C

Note: The XE0204 is available with an extended operating temperature range of -40C to +85C. To specify the version with the extended operating temperature range order XE0204-ITR.

XE0055CS2 Pin Configuration

XE0055CS2								
1	2	3	4	5	6	7	8	9
o	o	o	o	o	o	o	o	o
Ring	Tip	OH	T1	Gnd	Vcc	T2	/RI	CD

XE0055CS2 Pin Descriptions

Pin	Name	Description
1	Ring	Ring is one of two signals which form the telephone network connection (RJ11 Pin 4). This device is not sensitive to the polarity of the battery voltage on the telephone line. Ring has 1500 volts isolation from the rest of the circuitry. This isolation must be preserved throughout the system.
2	Tip	Tip provides the second connection to the telephone network (RJ11 Pin 3). Tip has 1500 volts isolation from the rest of the circuitry. This isolation must be preserved throughout the system.
3	OH	Hook-switch relay control input. A high on OH closes the internal relay and connects the equipment to the telephone line.
4	T1	T1 connects directly to the secondary side of the XE0055CS2 telephone line transformer.
5	GND	This pin is used as common reference for all of the control signals in the XE0055CS2. Signals on T1 and T2 are not referenced to ground.
6	VCC	VCC provides the power source for the hook-switch control. The XE0055CS2 will operate with VCC equal to either 3.3 or 5 volts
7	T2	T2 connects directly to the secondary side of the telephone line transformer of the XE0055CS2
8	/RI	Ring Indicate, output, active low, TTL, RI provides a half-wave representation of the Ring appearing on the telephone line. An external pull-up resistor is required to correctly bias the ring indicate output.
9	CD	The Connect Detect output indicates the status of the local telephone line. A high on CD indicates that the local telephone line is connected and is not currently in use. A low on CD indicates that the local telephone line is either disconnected from the XE0055CS2 or is being used by some other telephone equipment.

XE0055CS2 Electrical Specification ($V_{cc}=+5v \pm 10\%$, $T_a=0$ to 70 deg C)

Parameter	Conditions	Min	Typ	Max	Units
Power Supply Current	Off Hook, 5.0 Volts		10	15	mA
Transmit Insertion loss	600 Ohm Impedence, 1000 Hz	1.7	2.7	3.7	dB
Receive Insertion loss	600 Ohm Impedence, 1000 Hz	1.7	2.7	3.7	dB
Line Impedance	At 1000 Hz, Rm 340 ohms	540	600	660	Ohms
Coupler Match Input impedance	Input impedance to T1 & T2	386	390	394	Ohms
Ring Detect Sensitivity	Min. AC voltage between Tip & Ring Type B ringer	38		150	Vrms
Ring Detect Peak Current	Ringing Voltage of 40 Vrms applied across Tip and Ring	100			uA
Ring Detect Idle Current	No Ringing Voltage present			10	uA
Ring Indicate Output	Ring Voltage present on Tip and Ring		0.2	0.5	Volts
Hook Switch Control Voltage	ON: (off-hook)	2.0	3.0		Volts
	OFF: (on-hook)		0.2	0.5	Volts
Hook Switch Control Current	Off-Hook		15	25	mA
Loop Current	Off-Hook current draw from the Telephone Line	20		100	mA
Total Harmonic Distortion	At 1800 Hz, -9 dBm signal level	-72	-76		dBm

XE0055CS2 Typical Connection Diagram

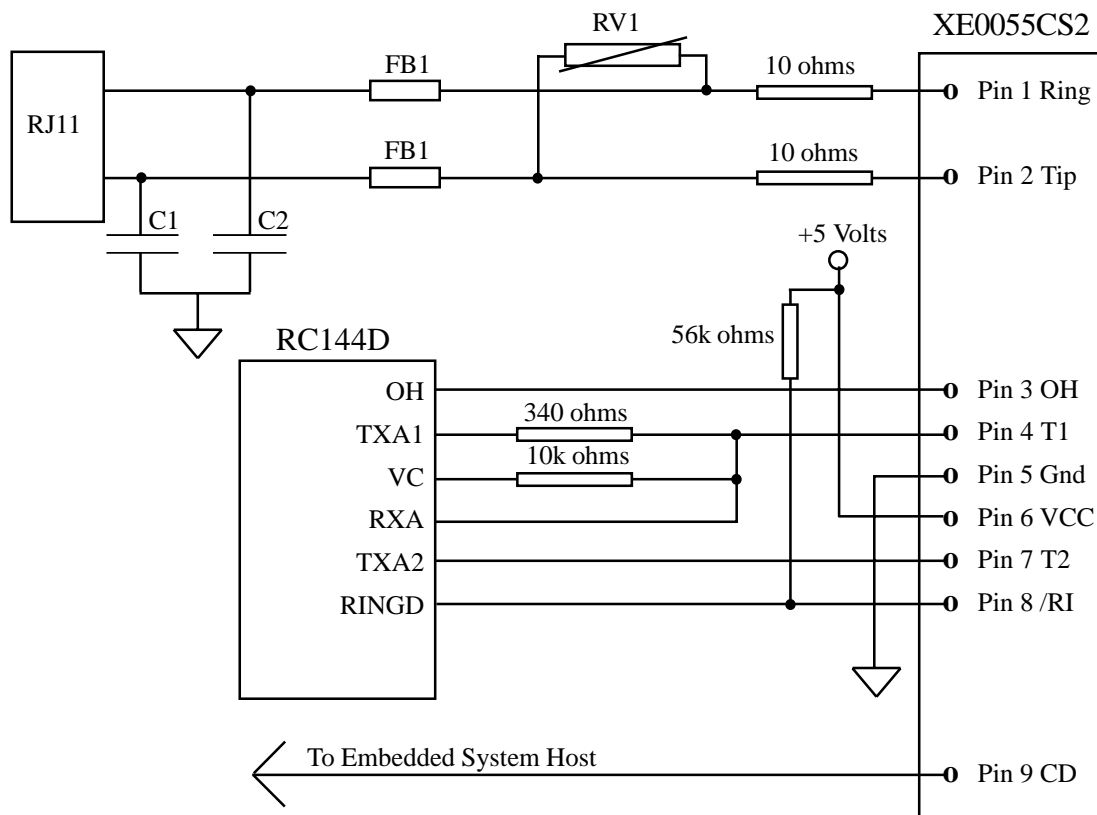

Notes:

FB1 and FB2 are ferrite beads. They work in conjunction with Capacitors C1 and C2 to eliminate EMI from the telephone cable. Xecom recommends a TDK CB30-1812 surface mount ferrite bead because it provides over 100 ohms impedance at 100 MHz.

C1 and C2 ground any EMI signal present on Tip and Ring. Xecom recommends a Sprague 30GAT47 capacitor. This is a 470 pF capacitor rated for 3000 Volts. The high voltage rating is required to maintain the required isolation barrier between the telephone line and ground.

RV1 is a solid-state protection device to reduce the likelihood of damage due to lightning strikes. RV1 works in conjunction with the two 10 ohm resistors to protect the XE0055CS2 circuitry. Xecom recommends the Teccor P3100 Sidactor for this function. Its typical breakover voltage of 310 volts prevents the XE0055CS2 from being exposed to voltage surges while being rated high enough to prevent being triggered by an incoming Ring signal.

FCC Part 68 Instructions

When developing a product to be connected to the telephone line, it is necessary to use a circuit known as a Data Access Arrangement (DAA) approved by the appropriate governmental agency. In the US this agency is the Federal Communications Commission (FCC), while in Canada it is Industry Canada (IC). These agencies test and approve the product to ensure that it meets their specifications, thereby protecting the telephone system from damage and protecting the user from high voltage transients (such as lightning strikes) which may come down the telephone line.

The XE0055CS2 has been designed to meet all FCC Part 68 requirements for hazardous voltage, line impedance and leakage current. If the system transmits data, synthesized voice, or DTMF tones on the telephone line, the user must certify that the signals transmitted meet basic FCC requirements for maximum transmission levels, out of band energy and billing delay. Full details may be obtained from the FCC under Part 68 of the FCC Rules and Regulations, or in Title 47 of the Code of Federal Regulations, however the basic requirements are as follows:

1. Maximum Transmit Level

For the normal “permissive” (standard) telephone line, equipment which transmits data (such as a modem) must not exceed a transmission level of -9 dBm.

2. Out of Band Energy

Data equipment must not transmit “out of band” energy on the telephone line which exceeds the following limits:

Frequency		Range	Max. Power
3995 Hz	to	4005 Hz	-27 dBm
4005 Hz	to	12 kHz	-20 dBm
12 kHz	to	90 kHz	-55 dBm
90 kHz	to	270 kHz	-55 dBm
270 kHz	to	6 MHz	-15 dBm

3. DTMF Transmission Level

If the system is capable of DTMF dialing, the maximum DTMF transmission level must be less than 0 dBm averaged over a 3 second interval.

4. Billing Delay

A delay of 2 seconds or greater is required after the time the XE0055CS2 is taken “off hook” and before any information is transmitted. This is required to ensure that billing information may be exchanged between telephone company central offices without interference.

The user of the XE0055CS2 must certify to the FCC that the final system meets the requirements of Part 68 which include the criteria above as well as the high voltage protection provided by the XE0055CS2. This is generally accomplished through an independent testing lab which tests the System and submits the proper paperwork to the FCC for approval. Since the XE0055CS2 already complies with FCC Part 68 rules, this is a relatively simple process.

Terms of Sale

Devices sold by XECOM are covered by the warranty provisions appearing in its Terms of Sale only. XECOM makes no warranty, express, statutory, implied, or by description regarding the information set forth herein, or regarding the freedom of the described devices from patent infringement. XECOM makes no warranty of merchantability or fitness for any purposes. XECOM reserves the right to discontinue production and change specifications and prices at any time and without notice. This product is intended for use in normal commercial applications. Applications requiring extended temperature range, unusual environmental requirements, or high reliability applications, such as military, medical life-support or life-sustaining equipment, are specifically not recommended without additional processing and authorization by XECOM for such application.

Xecom assumes no responsibility for the use of any circuitry other than circuitry embodied in a Xecom product. No other circuits, patents, or licenses are implied.

Life Support Policy

Xecom's products are not authorized for use as Critical Components in Life Support Devices or Systems.

Life Support Devices or Systems are devices or systems which, (a) are intended for surgical implant into the body, or (b) support or sustain life, and whose failure to perform, when properly used in accordance with instructions provided in the labeling, can be reasonably expected to result in significant injury to the user.

A Critical Component is any component of a life support device or system whose failure to perform can be reasonably expected to cause failure of the life support device or system, or to affect its safety or effectiveness.

Copyright, Xecom © 1999

While Xecom, Inc. has made every effort to ensure that the information presented here is accurate, Xecom will not be liable for any damages arising from errors or omission of fact. Xecom reserves the right to modify specifications and/or prices without notice. Product mentioned herein are used for identification purposes only and may be trademarks and/or registered trademarks of their respective companies.



Xecom Incorporated
374 Turquoise Street, Milpitas, CA 95035
Ph:408-945-6640 Fax:408-942-1346
Email: info@xecom.com