



UNIVERSAL ADVANCED DOCSIS® 2.0 DOWNSTREAM MODULE

FEATURES

- **Integrated QAMLink® Advanced DOCSIS® 2.0 downstream modulator**
 - Supports 4, 16, 32, 64, 128, 256, 512 and 1024 QAM
 - Variable symbol rates up to 10 Mbaud
 - Programmable 80-tap dual square-root Nyquist filters
 - Programmable complex 24-tap T/2 predistortion filter
 - Digital interpolation filters
 - Quadrature direct digital frequency synthesizer and upconverter
 - X/sinX filter for DAC distortion compensation
- **Fully integrated ITU-T J.83 Annex A (DVB/DAVIC/EuroDOCSIS™/IEEE 802.14), Annex B (DigiCipher II®/SCTE/DOCSIS/IEEE 802.14), and Annex C (Japan) FEC encoder**
 - All codes extended to support 512/1024-QAM
 - On-chip 64 KB static RAM for interleaving
- **Integrated 10-bit digital-to-analog converter**
- **Integrated additional burst modulator for power management of CPE equipment**
- **Optional 12-bit or 14-bit digital IF output for external DAC**
- **Broadcom Serial Control (BSC) or SPI-compatible microcontroller interface**
- **JTAG test interface**
- **128-pin PQFP package**
- **Operates over industrial temperature range (-40°C to +85°C)**

SUMMARY OF BENEFITS

- **Presents a high-performance, integrated solution for modulators in digital cable TV headend, DOCSIS 2.0 cable modem termination systems (CMTS), digital microwave radio, SMATV, and MMDS applications**
- **An integrated solution that reduces board space and costs with:**
 - On-chip 64-KB static RAM to eliminate external RAM
 - Integrated 10-bit DAC with power control
 - Additional burst modulator for out-of-band signaling
 - Small footprint to enable high-density equipment
- **Improves bandwidth efficiency through 512/1024 QAM modulation**
 - Enables advanced digital services over narrow RF channels
- **Supports North American, European, and Asian modulator standards, enabling a single design for worldwide application**
- **Programmable analog IF outputs up to 100 MHz simplify image rejection filters**
- **Programmable high-granularity digital output options remove the need for SAW filters in the final RF stage while providing designers multiple options in DAC selection**
- **Advanced functions ease deployments in harsh environments**
 - Distributed CMTS in Hybrid Fiber Coaxial Fiber Node

Cable Modem Termination System (CMTS) Block Diagram

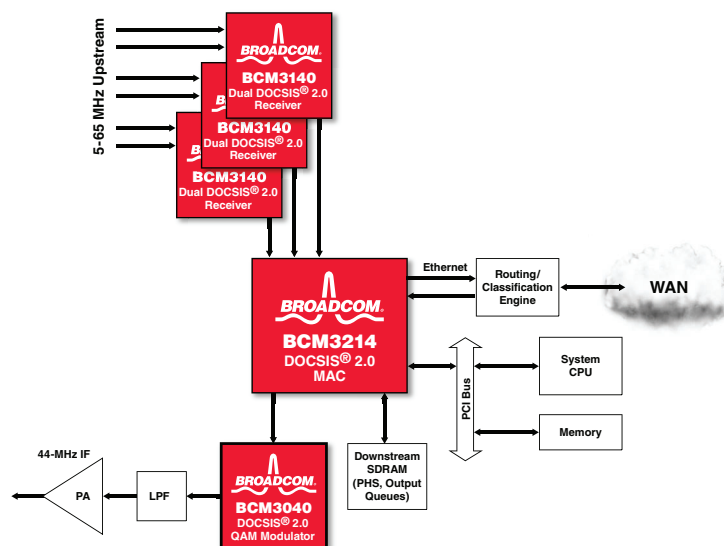

OVERVIEW

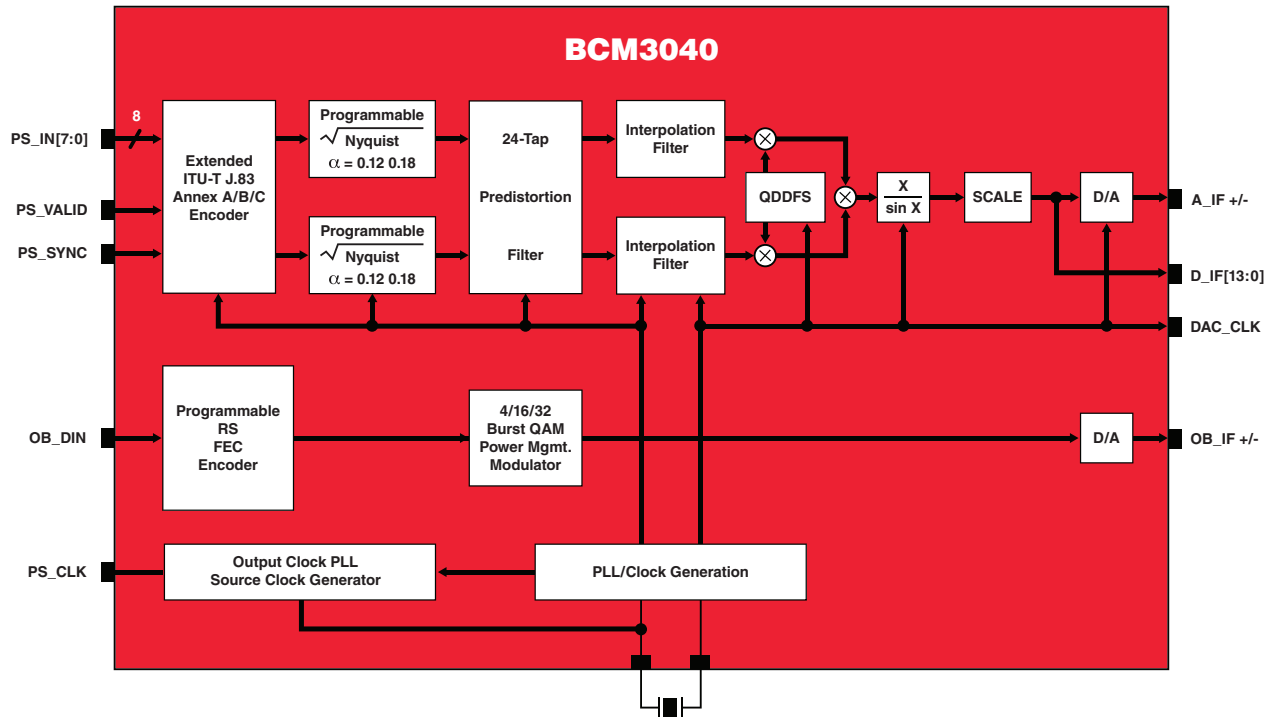

BCM3040 Block Diagram

The BCM3040 QAMLink Universal Modulator is a highly integrated solution that significantly decreases the board space and cost of modulators in digital cable TV headends, digital cable modem headends, digital microwave radio, SMATV, and MMDS applications. The BCM3040 features an advanced downstream QAM modulator that includes an extended ITU-T J.83 Annex A/B/C FEC encoder, an all-digital QAM modulator supporting up to 1024 QAM, and an integrated 10-bit DAC with power control. Additionally, the BCM3040 includes a second modulator that can be used for out-of-band signaling or CPE power control.

The advanced downstream QAM modulator supports symbol rates up to 10 Mbaud and symbol constellations from QPSK up to 1024-QAM, enabling up to 100 Mbps operation. The modulator accepts either a serial or parallel data stream, optionally recovers the data timing, and encodes the data with one of the supported coding standards. The resulting stream of QAM symbols then enters the modulator where the data pulses are shaped by the dual programmable linear phase square-root Nyquist filters. Built-in coefficients are provided for these filters for industry-standard excess bandwidth factors (alpha = 12%, 15%, or 18%). The filtered data is then passed through a 24-tap complex T/2-spaced

predistortion filter. This filter allows the user to compensate for non-idealities, such as slope distortion, introduced elsewhere in the RF portion of a design. Interpolation filters then upsample the signal to the output sample rate while providing additional signal filtering. A quadrature direct digital frequency synthesizer and I/Q modulator allow the QAM spectrum to be mixed to a precise output center frequency. The spectrum can then be predistorted by the integrated X/sinX filter to compensate for DAC distortion. The final signal can be output to the integrated 10-bit, 200-Msps DAC, which includes differential analog outputs and a gain stage that can set the output power in 0.4 dB steps. Alternatively, a selectable 12-bit or 14-bit digital IF output can drive an external DAC with sufficient linearity to enable final RF sections that do not require the use of SAW filters to meet industry-standard RF output templates.

The BCM3040 is a flexible, cost-effective worldwide solution. Because the chip accepts variable data rates and supports multiple digital transmission standards, manufacturers only need to develop one modulator for worldwide usage. The integrated feature set in the BCM3040 significantly reduces the board space in modulators, giving manufacturers a chip solution that is both cost-effective and easy to use.

Broadcom®, the pulse logo, Connecting everything®, the Connecting everything logo, and QAMLink® are among the trademarks of Broadcom Corporation and/or its affiliates in the United States, certain other countries and/or the EU. Any other trademarks or trade names mentioned are the property of their respective owners.

Connecting
everything®



BROADCOM CORPORATION
16215 Alton Parkway, P.O. Box 57013
Irvine, California 92619-7013

© 2006 by BROADCOM CORPORATION. All rights reserved.

3040-PB04-R 07/21/06

Phone: 949-450-8700
Fax: 949-450-8710
E-mail: info@broadcom.com
Web: www.broadcom.com