

RoHS Compliant Copper Small Form-factor Pluggable (SFP) Transceiver for Gigabit Ethernet with Rx-Los Indicator



Description

The LCP-1250RJ3SR-L is a 3.3V copper small form-factor pluggable (SFP) transceiver. It offers full duplex 1000 Mb/s Ethernet by transporting data over CAT 5 UTP cable (category 5 unshielded twisted pair), with RJ-45 connection. It takes signals from both CAT 5 UTP cable and the SFP SerDes interface.

The LCP-1250RJ3SR-L provides the SFP's RX_LOS pin for the link indication of cable side, and also, 1000Base-T auto-negotiation is enabled at default over cable link.

The system host should disable 1000 BASE-X auto-negotiation while LCP-1250RJ3SR-L is used.

The Gigabit Ethernet SFP ports on host systems can work well plugging with both of Delta fibre SFP transceiver and Delta copper SFP transceiver, so there is no need of software to configure MAC on host system.

At enhance, the software can configure the PHY device inner LCP-1250RJ3SR-L via SFP two-wire-inter- face. LCP-1250RJ3SR-L can also be operate on SGMII mode, which provides with tri-speed mode, 10/100/1000 Mbps operation over 1.25 GHz serial interfaces, as long as the host

system supports the SGMII interface with no clock mode on SFP cage. The SGMII interface without clock is selected by setting HWCFG_MODE[3:0] bits to '0100'.

Features

- Compatible with specifications for IEEE 802.3z/Gigabit Ethernet
- Compliant with MSA specifications for small Form Factor Pluggable (SFP) Ports
- Hot-pluggable SFP footprint
- 1000 BASE-T operation in the host system with SerDes interface (Default)
- 10/100/1000 BASE-T operation in the host system with SGMII interface (To be configured)
- Compliant with industry standard RFT electrical connector and cage
- EEPROM with serial ID functionality
- LCP-1250RJ3SR-L supports RX_LOS enabled
- Internal PHY IC is configurable by host system software via SFP 2-wire-interface

Applications

- Gigabit Ethernet over copper
- Switch to Switch interface
- Switched backplane applications
- File server interface

Performance

- LCP-1250RJ3SR-L data link up to 100m on standard CAT 5 UTP

Oct. 2007 Rev. 1.02

Product Selection

Part Number	LCP-1250RJ3SR *note1	LCP-1250RJ3SR-L *note2	LCP-1250RJ3SR-S *note3
Link Indicator On RX_LOS Pin	N/A	Available	N/A
Auto-negotiation on MAC side Enabled by default	1000Base-X	Yes	SGMII
MAC side Interface	1.25Gbps SerDes	1.25Gbps SerDes	SGMII without clock
Auto-negotiation on copper side Enabled by default	1000Base-T	1000Base-T	1000Base-T
Speed Mode (default)	1000Mbps only	1000Mbps only	10/100/1000Mbps

Notes:

1. This part supports the 1000 Base-T with SerDes interface by default. It can operate in 10/100/1000 Base-T with SGMII interface by reconfiguration of the PHY within the SFP.
2. This part uses the SFP's Rx-Los pin for link indication and 1000 Base-T auto-negotiation should be disabling on the host system. It can operate in 10/100/1000 Base-T with SGMII interface by reconfiguration of the PHY within the SFP.
3. This part supports the 10/100/1000 Base-T with SGMII interface by default.

Serial Interface Configuration (PHY Two-Wire Address 0xAC)

Register	Bits	Field	Mode	Description
27	3:0	HWCFG_MODE	R/W	Changes to these bits are disruptive to the normal operation; hence, any changes to these registers must be followed by software reset to take effect. Upon hardware reset Register 27.3:0 defaults to the value in HWCFG_MODE[3:0]. 0100 = SGMII without Clock with SGMII Auto-Neg to copper 1000 = 1000BASE-X without Clock with 1000BASE-X Auto-Neg to copper (GBIC) 1100 = 1000BASE-X without Clock without 1000BASEX Auto-Neg to copper

Absolute Maximum Ratings

Parameter	Symbol	Min.	Typ.	Max.	Unit	Note
Storage Temperature	T _s	-40		85	°C	
Supply Voltage	V _{cc}	0		5	V	

Recommended Operating Conditions

Parameter	Symbol	Min.	Typ.	Max.	Unit	Note
Ambient Operating Temperature	T _A	0		70	°C	
Supply Voltage	V _{cc}	3.135		3.465	V	

Oct. 2007 Rev. 1.02

Electrical Characteristics

($T_A=0\text{ }^{\circ}\text{C}$ to $70\text{ }^{\circ}\text{C}$, $V_{CC}=3.135\text{V}$ to 3.465V)

Parameter	Symbol	Min.	Typ.	Max.	Unit	Note
Supply Current	I_{CC}		350	400	mA	
Transmitter						
Transmitter Differential Input Voltage	$V_{D,TX}$	0.5		2.4	V	1
Differential Input Impedance	Z_{TX}	80	100	120	Ohm	
Transmitter Disable Input-High	V_{DISH}	2.0		$V_{CC}+0.3$	V	
Transmitter Disable Input-Low	V_{DISL}	0		0.8	V	
Receiver						
Data Output Differential Voltage	$V_{D,RX}$	0.35		2	V	3
Differential Output Impedance	Z_{RX}	80	100	120	Ohm	
Data Output Rise/Fall Time	$t_{r,Rx}/t_{f,Rx}$		180		ps	4
LOS Output Voltage-High	V_{SDHL}	2.0		$V_{CC}+0.3$	V	2
LOS Output Voltage-Low	V_{SDL}	0		0.8	V	2

Notes:

1. Internally AC coupled and terminated to 100-Ohm differential load.
2. Pull up to V_{CC} with a 4.7K – 10K Ohm resistor on host Board
3. Internally AC coupled, but requires a 100-Ohm differential termination at MAC side.
4. These are unfiltered 20%~80% values

SFP Transceiver Electrical Pad Layout

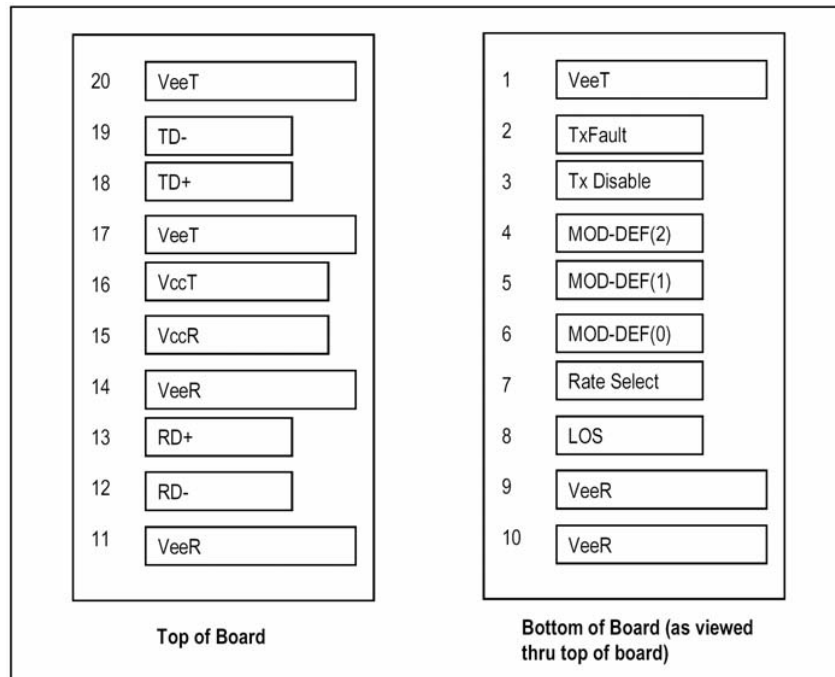

Oct. 2007 Rev. 1.02

Pin Function Definitions

Pin Num.	Name	Function	Plug Seq.	Notes
1	VeeT	Transmitter Ground	1	Note 5
2	TX Fault	Transmitter Fault Indication	3	Note 1 - Function not available
3	TX Disable	Transmitter Disable	3	Note 2 - Module disables on high or open
4	MOD-DEF2	Module Definition 2	3	Note 3 - Two-wire serial ID interface
5	MOD-DEF1	Module Definition 1	3	Note 3 - Two-wire serial ID interface
6	MOD-DEF0	Module Definition 0	3	Note 3 - grounded in module
7	Rate Select	Not Connect	3	Function not available
8	LOS	Loss of Signal	3	Note 4 - Function not available
9	VeeR	Receiver Ground	1	Note 5
10	VeeR	Receiver Ground	1	Note 5
11	VeeR	Receiver Ground	1	Note 5
12	RD-	Inverse Received Data Out	3	Note 6
13	RD+	Received Data Out	3	Note 6
14	VeeR	Receiver Ground	1	Note 5
15	VccR	Receiver Power	2	Note 7 - 3.3V ± 5%
16	VccT	Transmitter Power	2	Note 7 - 3.3V ± 5%
17	VeeT	Transmitter Ground	1	Note 5
18	TD+	Transmitter Data In	3	Note 8
19	TD-	Inverse Transmitter Data In	3	Note 8
20	VeeT	Transmitter Ground	1	Note 5

Plug Seq.: Pin engagement sequence during hot plugging.

Notes:

- 1) TX Fault is not supported and tied to ground.
- 2) TX disable is an input that is used to reset the chip of Gigabit Ethernet PHY inside the copper SFP. It is pulled up within the module with a 4.7 – 10 K Ω resistor.

Low (0 – 0.8V):	Transmitter on
(>0.8, < 2.0V):	Undefined
High (2.0 – 3.465V):	Transmitter Disabled
Open:	Transmitter Disabled
- 3) These are the module definition pins. They should be pulled up with a 4.7K – 10KΩ resistor on the host board. The pull-up voltage shall be VccT or VccR. MOD-DEF 0 is grounded in the module to indicate that the module is present. MOD-DEF 1 and MOD-DEF 2 are the clock and data lines of the two-wire serial interface, respectively.
- 4) LOS (Loss of Signal) is the indicator signal of 1000BASE-T link-up/ link-down status. HIGH outputted of LOS indicates link-down, LOW is linkup status. The LOS signal operation on copper SFP transceiver differs from optical SFP applications. It should be, pulled up with a 4.7K – 10KΩ resistor on the host board.
- 5) VeeR and VeeT are internally connected within the copper SFP.
- 6) RD+ and RD- are the received differential outputs, and they are AC-coupled 100Ω differential lines that should be terminated with 100Ω (differential) at user's SERDES. The AC coupling is done inside the copper SFP and thus not required on the host board. The differential voltage swing will be between 250mV and 625 mV, while properly terminated.

Oct. 2007 Rev. 1.02

- 7) VccR and VccT are the receiver and transmitter power supplies, and they are internally connected within the copper SFP. The power rail is defined as 3.3V \pm 5% at the SFP connector pin.
- 8) TD+ and TD- are the transmitted differential inputs, and they are terminated with 100 Ω differential load inside the module. The AC coupling is done inside the module, and thus not required on the host board.

Recommend Circuit Schematic

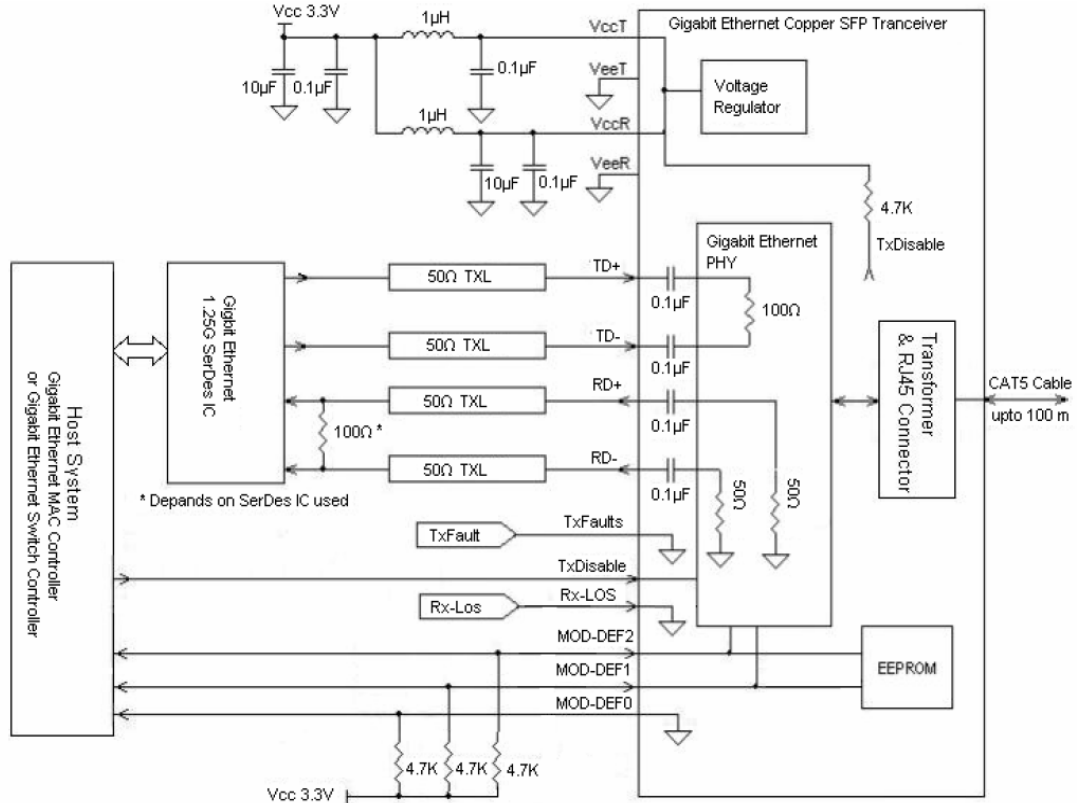

Package Outline Drawing for Metal Housing

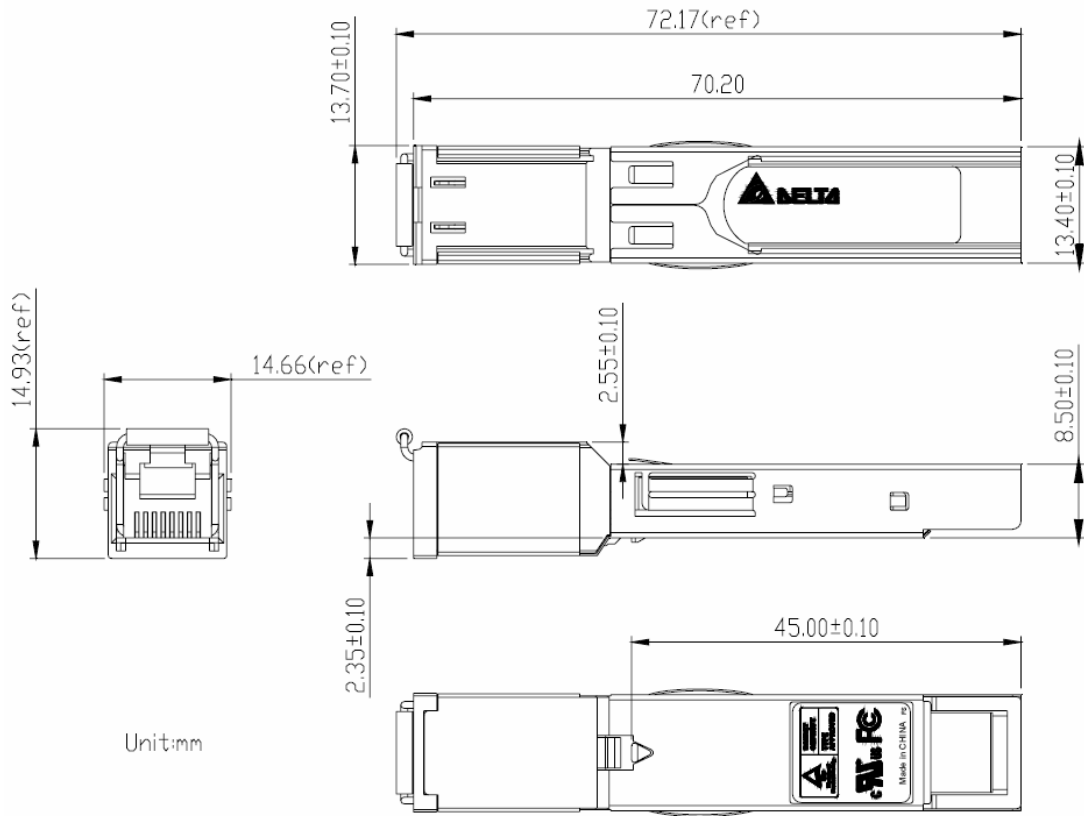

LCP-1250RJ3SR-L EEPROM Serial ID Memory Contents (Two-Wire Address A0h)

Address	Hex	ASCII	Address	Hex	ASCII	Address	Hex	ASCII	Address	Hex	ASCII	Address	Hex	ASCII	Address	Hex	ASCII
00	03		25	20		50	33	3	75	SN		100	00		125	00	
01	04		26	20		51	53	S	76	SN		101	00		126	00	
02	00		27	20		52	52	R	77	SN		102	00		127	00	
03	00		28	20		53	2D	-	78	SN		103	00				
04	00		29	20		54	4C	L	79	SN		104	00				
05	00		30	20		55	20		80	SN		105	00				
06	08		31	20		56	30	0	81	SN		106	00				
07	00		32	20		57	30	0	82	SN		107	00				
08	00		33	20		58	30	0	83	SN		108	00				
09	00		34	20		59	30	0	84	DC	Note 3	109	00				
10	00		35	20		60	00		85	DC		110	00				
11	01		36	00		61	00		86	DC		111	00				
12	0D		37	00		62	00		87	DC		112	00				
13	00		38	00		63	CS1	Note 1	88	DC		113	00				
14	00		39	00		64	00		89	DC		114	00				
15	00		40	4C	L	65	01		90	DC		115	00				
16	00		41	43	C	66	00		91	DC		116	00				
17	00		42	50	P	67	00		92	00		117	00				
18	64		43	2D	-	68	SN	Note 2	93	00		118	00				
19	00		44	31	1	69	SN		94	00		119	00				
20	44	D	45	32	2	70	SN		95	CS2	Note 4	120	00				
21	45	E	46	35	5	71	SN		96	00		121	00				
22	4C	L	47	30	0	72	SN		97	00		122	00				
23	54	T	48	52	R	73	SN		98	00		123	00				
24	41	A	49	4A	J	74	SN		99	00		124	00				

Notes:

- 1) Byte 63(CS1): Check sum of bytes 0-62.
- 2) Byte 68-83 (SN): Serial number.
- 3) Byte 84-91 (DC): Date code.
- 4) Byte 95 (CS2): Check sum of bytes 64-94.
- 5) Byte 128-255 had been set hex.00.

LCP-1250RJ3SR-L Internal PHY Register (Two-Wire Address 0xAC)

LCP-1250RJ3SR-L is internally designed of physical layer IC (Marvell 88E1111), which can be programmed via two-wire interface with the device address **0xAC**. For details of PHY IC registers in 88E1111, see Marvell document “*Alaska Ultra 88E1111 Integrated Gigabit Ethernet Transceiver*”.

Electromagnetic Emission

FCC Class A, CE Class A, VCCI Class A, C-Tick

Related Product

1. **LCP-1250RJ3SR**, SFP Copper Transceiver, IEEE 802.3z/Gigabit Ethernet, standard CAT 5 UTP
2. **GBIC-1250RJ3SR**, GBIC Transceiver, 1250Mb/s, data link up to 100 m on standard CAT 5 UTP.
3. **LCP-1250RJ3SR-S**, SFP Copper Transceiver with SGMII interface, IEEE 802.3z/Gigabit Ethernet, standard CAT 5 UTP

References

1. "Small Form-factor Pluggable (SFP) Transceiver MultiSource Agreement (MSA)", September 14, 2000
2. "IEEE Std 802.3, 2002 Edition". IEEE Standards Department, 2002.
3. "AT24C01A/02/04/08/16 2-Wire Serial CMOS EEPROM", Atmel Corporation. www.atmel.com
4. "Alaska Ultra 88E1111 Integrated 10/100/1000 Gigabit Ethernet Transceiver", Marvell Corporation. www.marvell.com
5. "Serial-GMII Specification Revision 1.8", Cisco System Corporation. www.cisco.com,