



## 16-PORT 1GB, 2G, 4GBPS FIBRE CHANNEL FABRIC SWITCH

### FEATURES

- Highly integrated System-on-Chip (SOC)
- 16 Fibre Channel ports
- 32 bit, 66MHz PCI interface
- Integrated SERDES
- 1G, 2G, 4G Link Data Rates
- Auto-speed Negotiation
- N, NL, F, FL and E Port Types
- Point-to-Point, Fabric and Arbitrated Loop topologies
- Per-port Frame Processing
- Public / Private Address translation
- Hardware Zoning
- 2 Virtual Channels per port
- 17 BB credit per port
- Non-blocking Cross-bar, Arbiter / Scheduler
- 128 Gbps aggregate switching bandwidth
- Less than 1usec latency
- Integrated statistics
- Internal data-path protection
- JTAG, Memory BIST, Active SI / Active LI Diagnostics, Link and system loop-backs
- LED controller per port
- High Performance 0.13u process technology
- 12W power consumption: 1.25V core, 2.5V/3.3V I/O
- 40mm x 40mm, 792 pin EPGA package

### APPLICATIONS

- Fabric Switch
- Embedded Fabric Switch
- Root Fabric Switch
- RAID
- FBOD, SBOD

### BENEFITS

- Enables highly reliable, low-cost, small form-factor system design
- Highly integrated
- Low power consumption
- Features and flexibility providing a broad range of deployment applications
- Reference system design available
- Fabric services and Device Driver Software

### BCM8440 - Based Fabric Switch

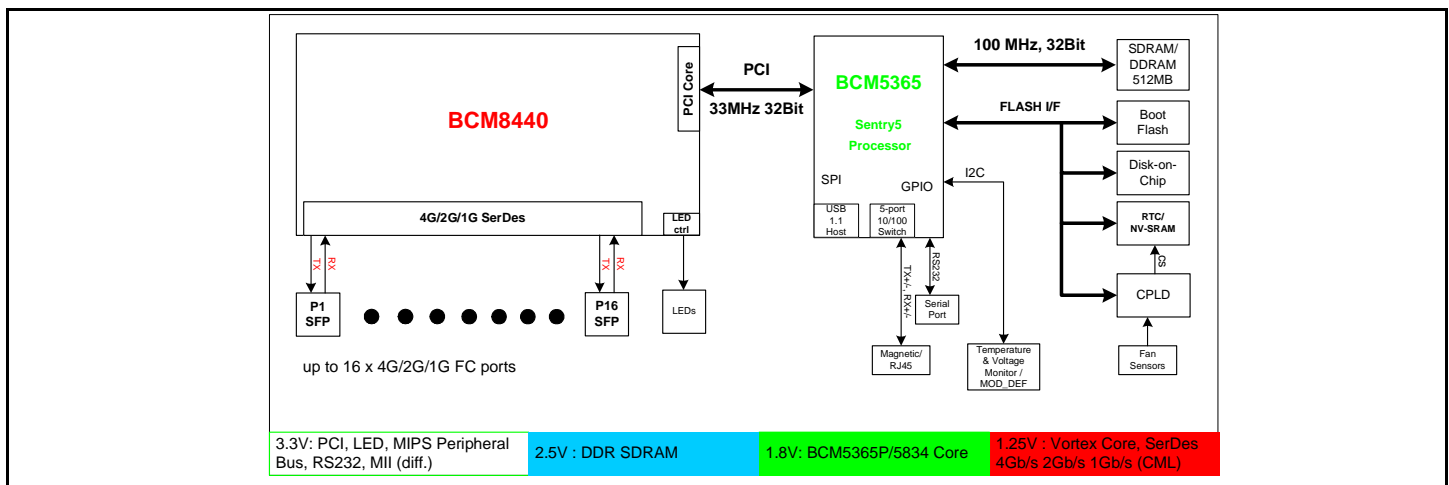

## OVERVIEW

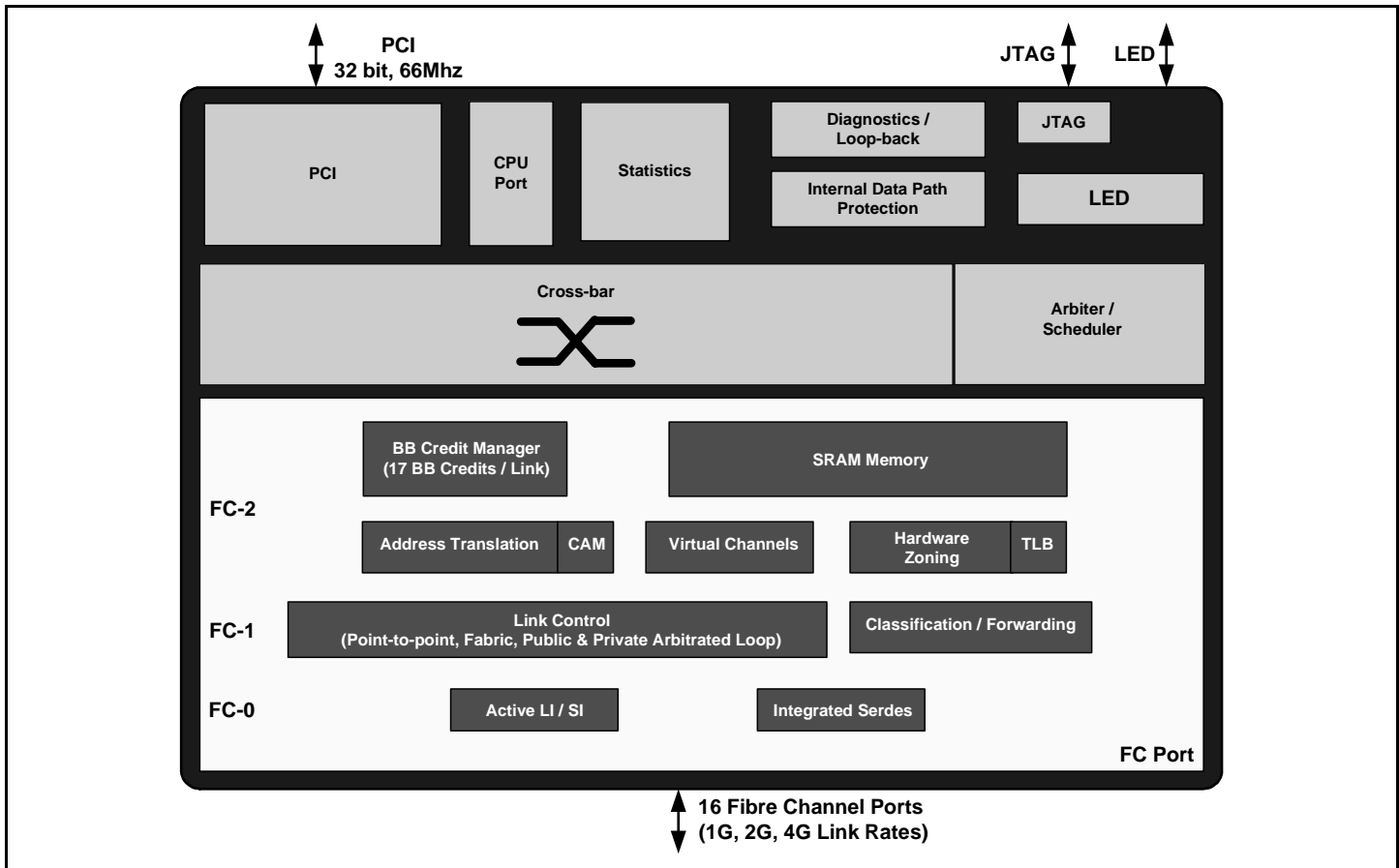

The BCM8440 Fibre Channel Fabric Switch IC offers a high level of system integration, performance and features for next generation Fibre Channel switches. Because of the small form factor and low power the BCM8440 is ideal for embedded Fibre Channel Fabric Switch applications or cost effective stand-alone switches.

The BCM8440 contains 16 Fibre Channel link ports that incorporate integrated SERDES drivers. A 32bit, 66Mhz PCI interface allows ubiquitous connectivity to common CPU complexes and legacy systems.

The Broadcom reference design is based on the industry-proven MIPs processor.

To accelerate the product development cycle, Broadcom can support the design of Fibre Channel switching solutions, including device drivers, Fabric Services software, reference designs through full turn-key development. Standards and Inter-operability testing can also be provided.

### Interfaces

- Sixteen Fibre Channel links
- 32bit, 66MHz PCI
- LED status
- JTAG

**Broadcom**<sup>®</sup>, the pulse logo, and **Connecting everything**<sup>®</sup> are trademarks of Broadcom Corporation and/or its subsidiaries in the United States and certain other countries. All other trademarks mentioned are the property of their respective owners.

Connecting  
**everything**<sup>®</sup>



**BROADCOM CORPORATION**  
16215 Alton Parkway, P.O. Box 57013  
Irvine, California 92619-7013

© 2004 by BROADCOM CORPORATION. All rights reserved.

8440-PB01-R 03/01/04

Phone: 949-450-8700  
Fax: 949-450-8710  
E-mail: [info@broadcom.com](mailto:info@broadcom.com)  
Web: [www.broadcom.com](http://www.broadcom.com)