

DESCRIPTION

The HI-8420 is a six channel discrete-to-digital interface device. The HI-8423 has eight channels. Mixed-signal CMOS technology is used to provide superior low-power performance. The device inputs are configured to sense Ground / Open discrete signals. The device outputs are CMOS / TTL compatible and may be disabled (tri-state) using the \overline{CE} and \overline{OE} pins.

The HI-8420 is a drop-in replacement for the DEI1026.

For added functionality, the Holt HI-8422 offers eight channels of Open / Ground sensing and eight channels of 28V / Ground sensing in a single device.

BLOCK DIAGRAM

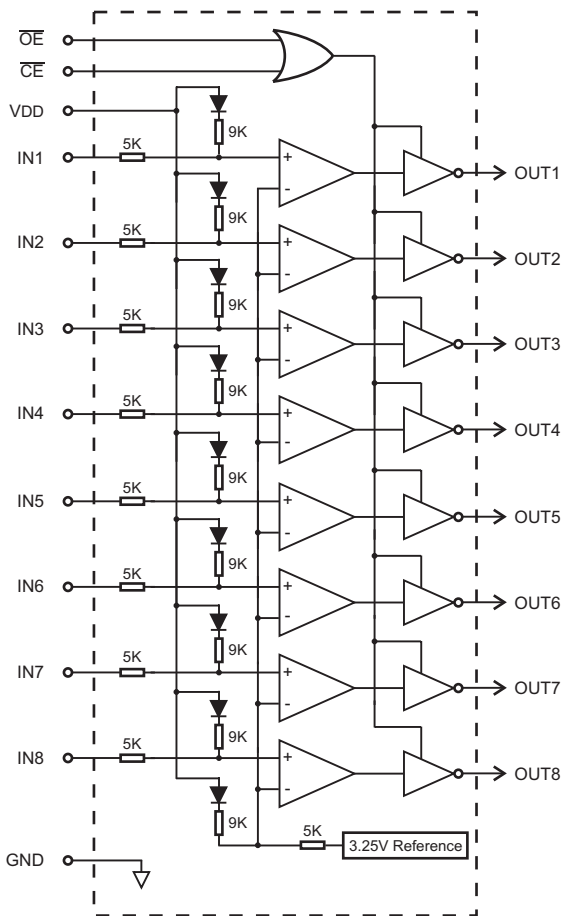

FEATURES

- 6 or 8 independent Open / Ground sensing channels
- 5.0V single supply operation
- Low power CMOS technology
- Lightning protected inputs to DO-160D level 3
- HI-8420 is a drop in replacement for DEI1026

PIN CONFIGURATIONS

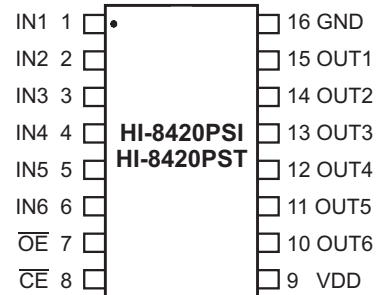

**16-Pin Plastic SOIC package
(Narrow Body)**

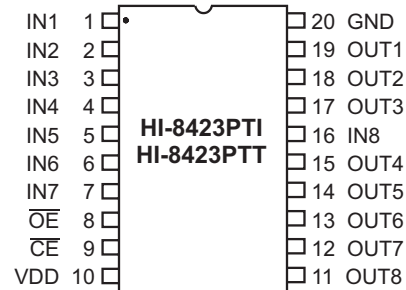

20 Pin TSSOP package

FUNCTION TABLE

Discrete Input	\overline{CE}	\overline{OE}	Output
Open	0	0	0
Ground	0	0	1
X	1	X	High Z
X	X	1	High Z

PIN DESCRIPTIONS

PIN		SYMBOL	FUNCTION	DESCRIPTION
(HI-8420)	(HI-8423)			
1	1	IN1	Discrete Input	Open / Ground sensing input, channel 1
2	2	IN2	Discrete Input	Open / Ground sensing input, channel 2
3	3	IN3	Discrete Input	Open / Ground sensing input, channel 3
4	4	IN4	Discrete Input	Open / Ground sensing input, channel 4
5	5	IN5	Discrete Input	Open / Ground sensing input, channel 5
6	6	IN6	Discrete Input	Open / Ground sensing input, channel 6
-	7	IN7	Discrete Input	Open / Ground sensing input channel 7
7	8	\overline{OE}	Digital input	Output Enable. OUT1-OUT8 are high-impedance if \overline{OE} is high
8	9	\overline{CE}	Digital input	Chip Enable. OUT1-OUT8 are high-impedance if \overline{CE} is high
9	10	VDD	Power	Positive supply voltage 5.0 V
-	11	OUT8	Tri-state output	Logic output, channel 8
-	12	OUT7	Tri-state output	Logic output, channel 7
10	13	OUT6	Tri-state output	Logic output, channel 6
11	14	OUT5	Tri-state output	Logic output, channel 5
12	15	OUT4	Tri-state output	Logic output, channel 4
-	16	IN8	Discrete Input	Open / Ground sensing input, channel 8
13	17	OUT3	Tri-state output	Logic output, channel 3
14	18	OUT2	Tri-state output	Logic output, channel 2
15	19	OUT1	Tri-state output	Logic output, channel 1
16	20	GND	Power	Ground

ABSOLUTE MAXIMUM RATINGS

Supply voltage (VDD)	-0.3 V to +7 V
Logic input voltage range	-0.3 V to +5.5 V
Discrete input voltage range	-5 V to + 35 V
Power dissipation at 25°C	350 mW
Solder temperature	275°C for 10 sec
Storage temperature	-65°C to +150°C

RECOMMENDED OPERATING CONDITIONS

Supply Voltage	
VDD	4.5 V to 5.5 V
Operating Temperature Range	
Industrial Screening	-40°C to +85°C
Hi-Temp Screening	-55°C to +125°C

NOTE: Stresses above absolute maximum ratings or outside recommended operating conditions may cause permanent damage to the device. These are stress ratings only. Operation at the limits is not recommended.

ELECTRICAL CHARACTERISTICS

VDD = 5.0V ± 10%, GND = 0V, TA = Operating Temperature Range (unless otherwise specified).

PARAMETER	SYMBOL	CONDITION	MIN	TYP	MAX	UNITS
DISCRETE INPUTS						
Ground state input voltage	VSG	Input voltage to give high output			3.0	V
Open state input voltage	VSO	Input voltage to give low output	3.5			V
Ground state input resistor	RIG	Resistor from input to ground to give high output	0		100	Ω
Open state input resistor	RIO	Resistor from input to ground to give low output	100			KΩ
Input source current	IIO	Current sourced into 100Ω to ground	-100	-330		μA
Reverse leakage current	IIR	VIN = 35 V, VDD = 0 V			5.0	mA
LOGIC INPUTS (\overline{CE}, \overline{OE})						
Input Voltage	Input voltage HI	V _{IH}	2.0			V
	Input voltage LO	V _{IL}			0.8	V
Input current	Input sink	I _{IH}			1.0	μA
	Input source	I _{IL}	-1.0			μA
OUTPUTS						
Logic output voltage	High	V _{OH}	2.4			V
	Low	V _{OL}			0.4	V
Logic output voltage (CMOS)	High	V _{OH}	V _{DD} - 0.2			V
	Low	V _{OL}			0.2	V
Tri-state output current		I _{OZ}			±10	μA
SUPPLY CURRENT						
VDD current		I _{DD}		5	10	mA
SWITCHING CHARACTERISTICS						
Propagation delay	IN to OUT	t _{LH} , t _{HL}			150	ns
Output enable time		t _{ZL} , t _{ZH}			25	ns
Output disable time		t _{LZ} , t _{HZ}			25	ns

TIMING DIAGRAMS

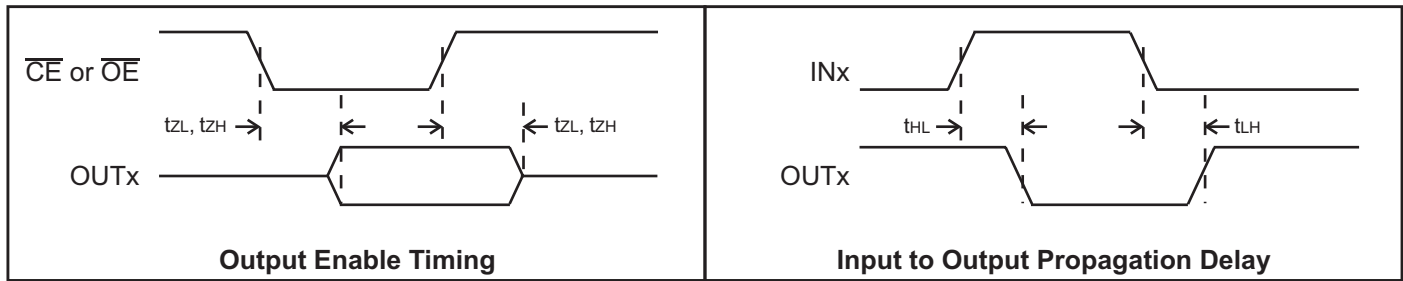

LIGHTNING PROTECTION

The Open / Ground inputs will survive DO-160D level 3, waveforms 3 and 4 without external components. In order to guarantee survival to waveform 5A an external series resistor of at least 3.3K Ω is recommended.

INPUT SWITCHING THRESHOLD

The input switching threshold of the Open / Ground inputs will decrease with increasing series resistance according to the function

$$V_T = 3.25 - 0.1R$$

where V_T is the nominal input switching threshold, and R is the value of the external series resistor in Kohms.

ORDERING INFORMATION

HI - 842xxx x x

PART NUMBER	LEAD FINISH
Blank	Tin / Lead (Sn / Pb) Solder
F	100% Matte Tin (Pb-free, RoHS compliant)

PART NUMBER	TEMPERATURE RANGE	FLOW	BURN IN
I	-40°C TO +85°C	I	NO
T	-55°C TO +125°C	T	NO

PART NUMBER	PACKAGE DESCRIPTION
8420PS	16 PIN PLASTIC NARROW BODY SOIC (16HN)
8423PT	20 PIN PLASTIC TSSOP (20HT)

16-PIN PLASTIC SMALL OUTLINE (SOIC) - NB
(Narrow Body)

inches (millimeters)
Package Type: 16HN

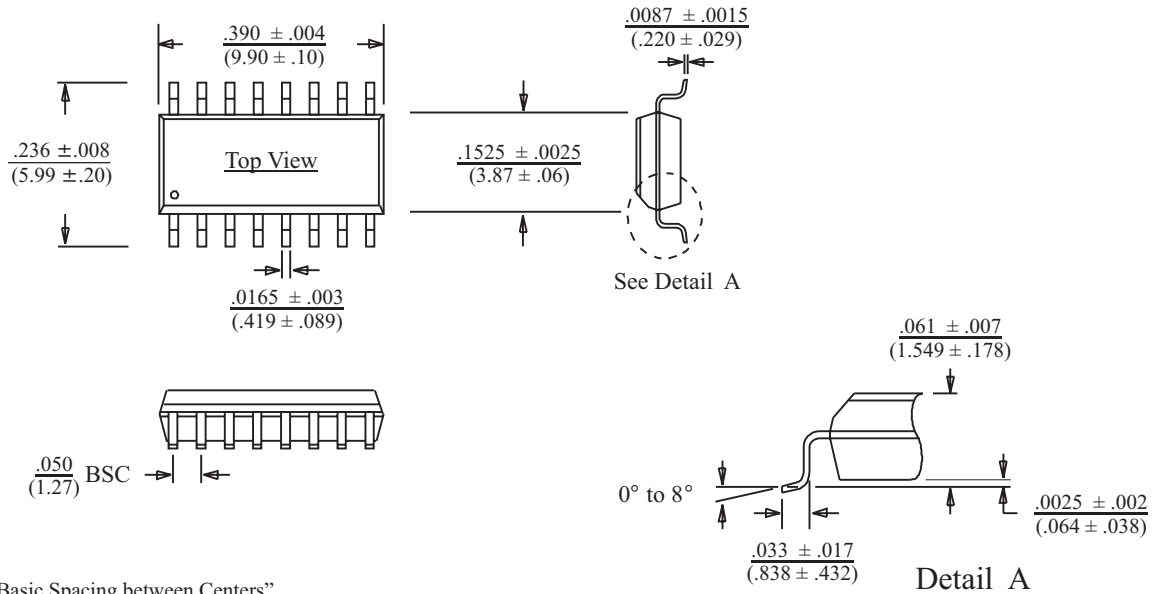

BSC = "Basic Spacing between Centers" is theoretical true position dimension and has no tolerance. (JEDEC Standard 95)

20-PIN PLASTIC TSSOP

inches (millimeters)
Package Type: 20HT

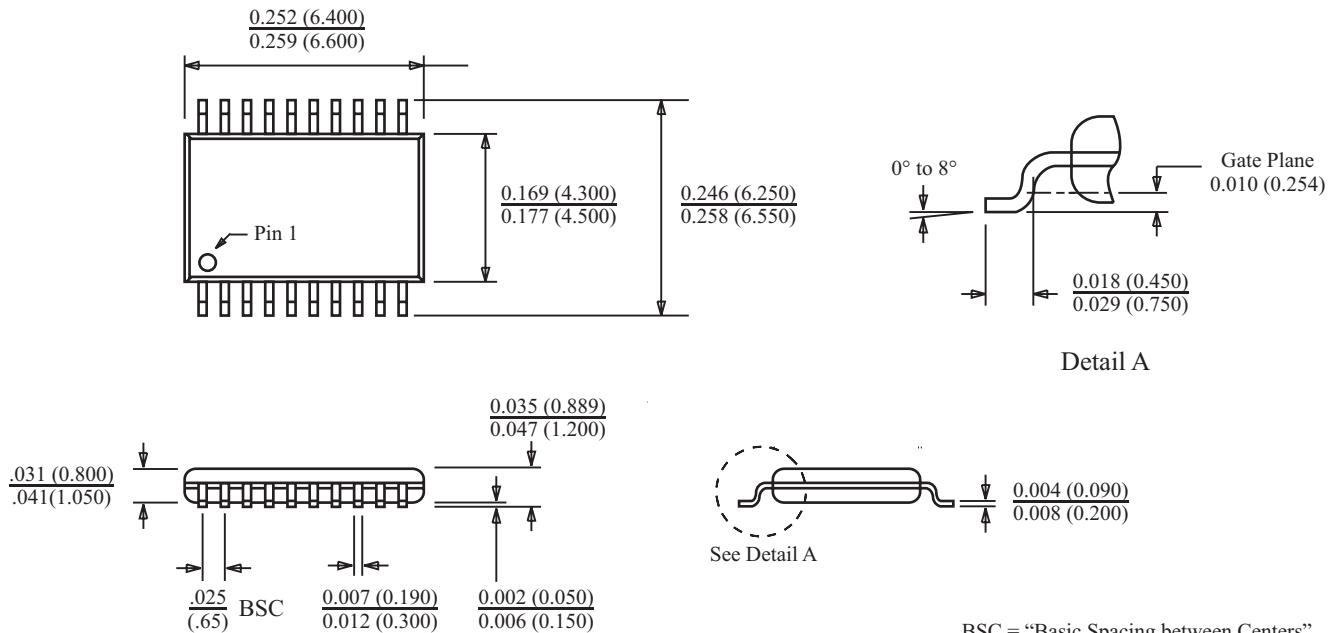

BSC = "Basic Spacing between Centers" is theoretical true position dimension and has no tolerance. (JEDEC Standard 95)