

March 2007

DESCRIPTION

The HI-8421 is a six channel discrete-to-digital interface device. The HI-8424 has eight channels. Mixed-signal CMOS technology is used to provide superior low-power performance. The device inputs are configured to sense 28V / Open discrete signals. The device outputs are CMOS / TTL compatible and may be disabled (tri-state) using the \overline{CE} and \overline{OE} pins.

The HI-8421 is a drop-in replacement for the DEI1054.

For added functionality, the Holt HI-8422 offers eight channels of Open / Ground sensing and eight channels of 28V / Ground sensing in a single device.

BLOCK DIAGRAM

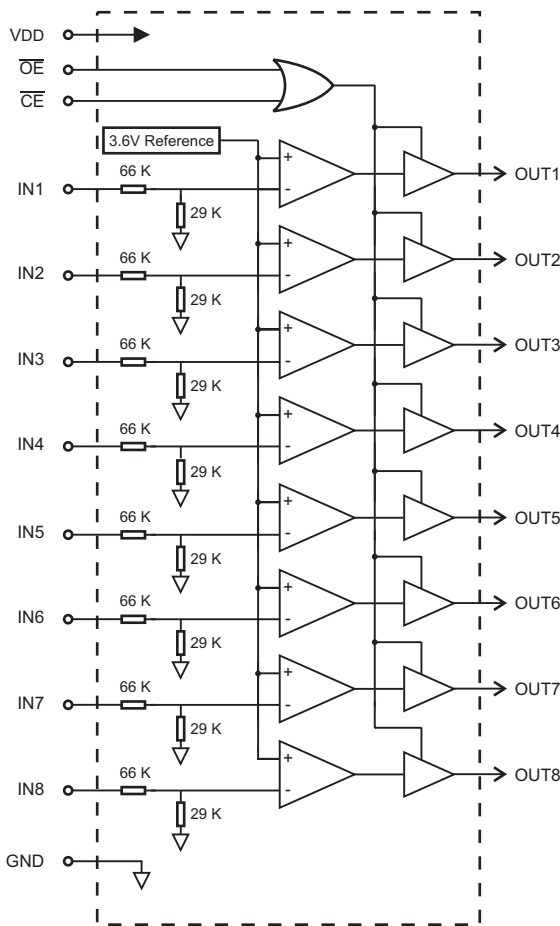

FEATURES

- 6 or 8 independent 28V / Open sensing channels
- 5.0V single supply operation
- Low power CMOS technology
- Lightning protected inputs to DO-160D level 3
- HI-8421 is a drop in replacement for DEI1054

PIN CONFIGURATIONS

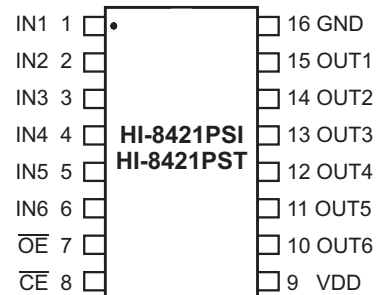

**16-Pin Plastic SOIC package
(Narrow Body)**

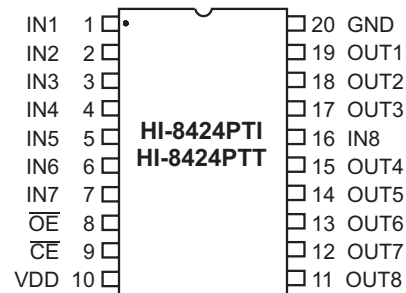

20 Pin TSSOP package

FUNCTION TABLE

Discrete Input	\overline{CE}	\overline{OE}	Output
Open	0	0	1
28 Volts	0	0	0
X	1	X	High Z
X	X	1	High Z

PIN DESCRIPTIONS

PIN		SYMBOL	FUNCTION	DESCRIPTION
(HI-8421)	(HI-8424)			
1	1	IN1	Discrete Input	28 Volt / Open sensing input, channel 1
2	2	IN2	Discrete Input	28 Volt / Open sensing input, channel 2
3	3	IN3	Discrete Input	28 Volt / Open sensing input, channel 3
4	4	IN4	Discrete Input	28 Volt / Open sensing input, channel 4
5	5	IN5	Discrete Input	28 Volt / Open sensing input, channel 5
6	6	IN6	Discrete Input	28 Volt / Open sensing input, channel 6
-	7	IN7	Discrete Input	28 Volt / Open sensing input channel 7
7	8	\overline{OE}	Digital input	Output Enable. OUT1-OUT8 are high-impedance if \overline{OE} is high
8	9	\overline{CE}	Digital input	Chip Enable. OUT1-OUT8 are high-impedance if \overline{CE} is high
9	10	VDD	Power	Positive supply voltage 5.0 V
-	11	OUT8	Tri-state output	Logic output, channel 8
-	12	OUT7	Tri-state output	Logic output, channel 7
10	13	OUT6	Tri-state output	Logic output, channel 6
11	14	OUT5	Tri-state output	Logic output, channel 5
12	15	OUT4	Tri-state output	Logic output, channel 4
-	16	IN8	Discrete Input	28 Volt / Open sensing input, channel 8
13	17	OUT3	Tri-state output	Logic output, channel 3
14	18	OUT2	Tri-state output	Logic output, channel 2
15	19	OUT1	Tri-state output	Logic output, channel 1
16	20	GND	Power	Ground

ABSOLUTE MAXIMUM RATINGS

Supply voltage (VDD)	-0.3 V to +7 V
Logic input voltage range	-0.3 V to +5.5 V
Discrete input voltage range	-80 V to + 80 V
Power dissipation at 25°C	350 mW
Solder temperature	275°C for 10 sec
Storage temperature	-65°C to +150°C

RECOMMENDED OPERATING CONDITIONS

Supply Voltage	
VDD	4.5 V to 5.5 V
Operating Temperature Range	
Industrial Screening	-40°C to +85°C
Hi-Temp Screening	-55°C to +125°C

NOTE: Stresses above absolute maximum ratings or outside recommended operating conditions may cause permanent damage to the device. These are stress ratings only. Operation at the limits is not recommended.

ELECTRICAL CHARACTERISTICS

VDD = 5.0V ± 10%, GND = 0V, TA = Operating Temperature Range (unless otherwise specified).

PARAMETER	SYMBOL	CONDITION	MIN	TYP	MAX	UNITS
DISCRETE INPUTS						
Open state input voltage	V _{SO}	Input voltage to give high output	-5		10	V
28 V state input voltage	V _{S28}	Input voltage to give low output	14			V
Open state input current	I _{SO}	Maximum input current to give high output			84	µA
28 V state input current	I _{S28}	Minimum input current to give low output	197			µA
Input resistance	R _{IN}	0 V < V _{IN} < 16 V	71		119	KΩ
Input current at 28 V	I _{IN28}	V _{IN} = 28 V			394	µA

ELECTRICAL CHARACTERISTICS (Cont.)

VDD = 5.0V ± 10%, GND = 0V, TA = Operating Temperature Range (unless otherwise specified).

PARAMETER	SYMBOL	CONDITION	MIN	TYP	MAX	UNITS	
LOGIC INPUTS (\overline{CE} , \overline{OE})							
Input Voltage	Input voltage HI	V_{IH}	2.0			V	
	Input voltage LO	V_{IL}			0.8	V	
Input current	Input sink	I_{IH}	$V_{IH} = V_{DD}$		1.0	μA	
	Input source	I_{IL}	$V_{IL} = 0 V$	-1.0		μA	
OUTPUTS							
Logic output voltage	High	V_{OH}	$I_{OH} = -5 mA$	2.4		V	
	Low	V_{OL}	$I_{OL} = 5 mA$		0.4	V	
Logic output voltage (CMOS)	High	V_{OH}	$I_{OH} = -100 \mu A$	$V_{DD} - 0.2$		V	
	Low	V_{OL}	$I_{OL} = 100 \mu A$		0.2	V	
Tri-state output current		I_{OZ}	$V_{OUT} = 0 V$ or V_{DD}		±10	μA	
SUPPLY CURRENT							
VDD current		I_{DD}	$V_{IN} = 0 V$ (all inputs)		5	10	mA
SWITCHING CHARACTERISTICS							
Propagation delay	IN to OUT	t_{LH}, t_{HL}			500	ns	
Output enable time		t_{ZL}, t_{ZH}	From \overline{CE} or \overline{OE}		25	ns	
Output disable time		t_{LZ}, t_{HZ}	From \overline{CE} or \overline{OE}		25	ns	

TIMING DIAGRAMS

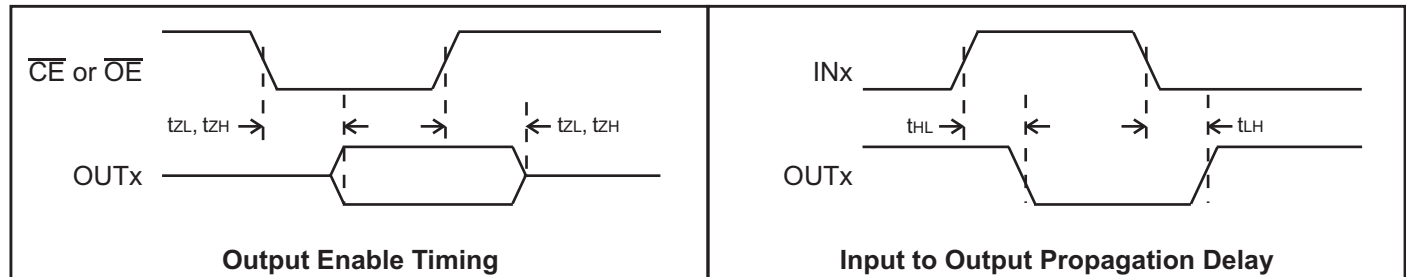

LIGHTNING PROTECTION

The 28V / Open inputs will survive DO-160D level 3, waveforms 3, 4 and 5A without external components.

ORDERING INFORMATION

HI - 842xxx x x

	LEAD FINISH		
Blank	Tin / Lead (Sn / Pb) Solder		
F	100% Matte Tin (Pb-free, RoHS compliant)		
PART NUMBER	TEMPERATURE RANGE	FLOW	BURN IN
I	-40°C TO +85°C	I	NO
T	-55°C TO +125°C	T	NO
PART NUMBER	PACKAGE DESCRIPTION		
8421PS	16 PIN PLASTIC NARROW BODY SOIC (16HN)		
8424PT	20 PIN PLASTIC TSSOP (20HT)		

16-PIN PLASTIC SMALL OUTLINE (SOIC) - NB (Narrow Body)

inches (millimeters)
Package Type: 16HN

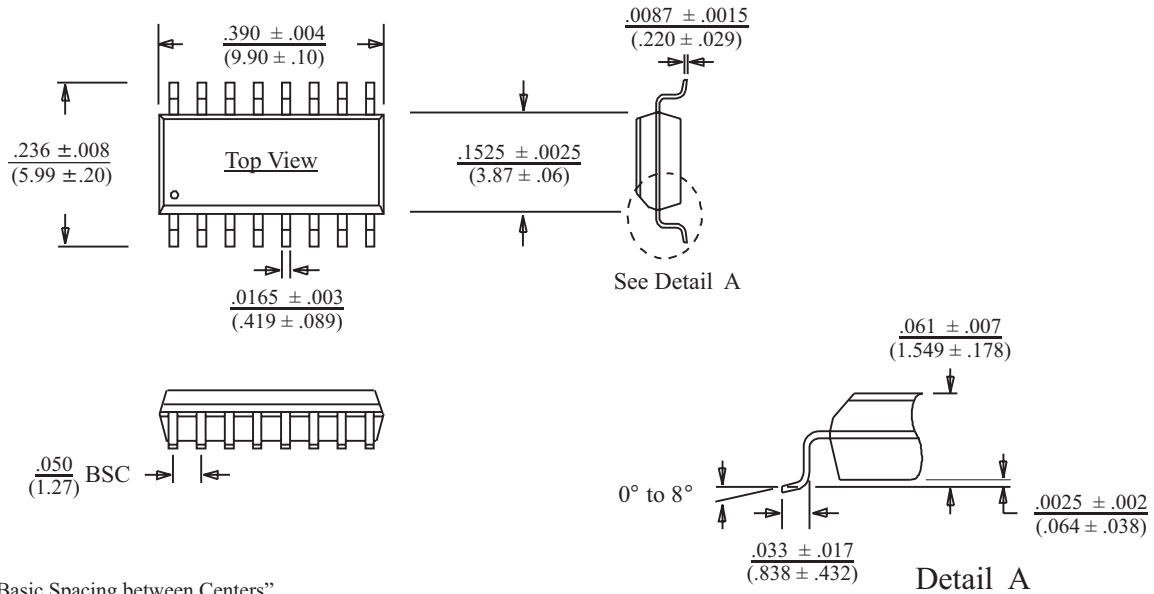

BSC = "Basic Spacing between Centers"
is theoretical true position dimension and
has no tolerance. (JEDEC Standard 95)

20-PIN PLASTIC TSSOP

inches (millimeters)
Package Type: 20HT

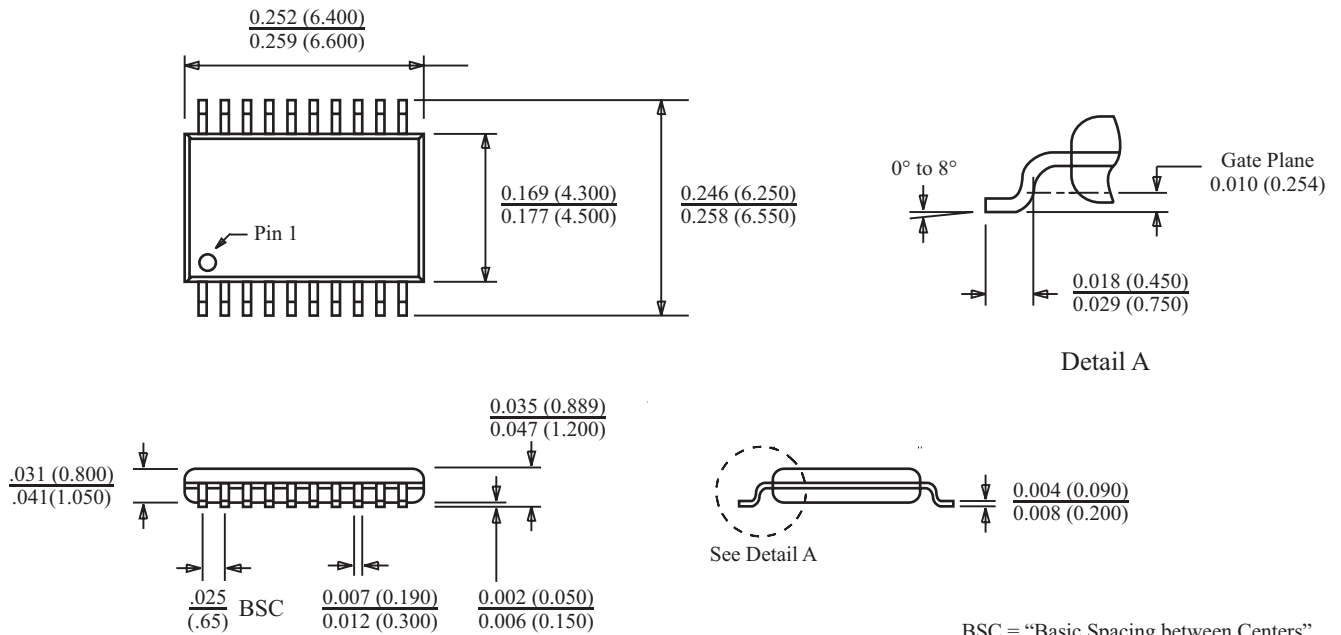

BSC = "Basic Spacing between Centers"
is theoretical true position dimension and
has no tolerance. (JEDEC Standard 95)