

# CH1817

## Family of Low Profile DAA Modules

### INTRODUCTION

The CH1817 is a Family of Low Profile Data Access Arrangement (DAA) Modules. They are compatible with all modem chip sets. These devices have been tested to meet or exceed FCC Part 68 requirements and are Canadian DOC approvable. They are also recognized by Underwriters Laboratories to UL 1459 Specifications.

The CH1817 modules are ultra small (1.0" x 1.0" x 0.35") affording an easy integration into space-sensitive designs, including laptop and hand-held computer based products. The CH1817 family of products may be socketed or mounted directly onto a Printed Circuit Board (PCB). The telephone line connection is made through TIP and RING to an RJ-11 jack or equivalent.

The CH1817 is intended for use with FAX/modem chip sets that have a data throughput of up through V.32bis. For High Speed Applications, Cermetek recommends the CH1837A.

### FUNCTIONAL DESCRIPTION

**Ring Detection.** Referring to the block diagram in Figure 1, incoming ring detection is performed by the CH1817 and the RI pin is set Low during the 2 second (typical) ring period and is restored to High for the 4 seconds (typical) between rings. During incoming ring signal activity, the  $\overline{RI}$  output is pulsed at the same frequency as the ringing signal, typically 20Hz. Figure 2 contains additional external circuitry which may be used to provide an envelope indication of the ring signal. The internal ring detection circuit is designed to deter false indications due to pulse dialing or noise on the line.

The  $\overline{RI}$  output of the CH1817 is diode protected. Therefore, an external pull-up resistor ( $R > 100K\Omega$ ) to +5V may be utilized to activate the ring detection circuit when the CH1817 is not connected to power. This can be handy in designs where power consumption is of concern. When circuited in this manner, there is virtually no current draw until a ring signal is present.

$\overline{RI}$
Output: Active low
Opto coupler, 30K $\Omega$ pull-up
Square wave: 15-68Hz (Typ. 20Hz)
Sensitivity: 38Vrms across Tip & Ring

### FEATURES

- Low Profile, Ultra small size: 1.0" x 1.0" x 0.35"
- Complete DAA function
- Ring detection
- Built-in 2-wire to 4-wire conversion
- Lightweight
- Multimedia compatible
- +5V operation
- 1000 VAC isolation
- 800 Volt surge protection
- V.32bis/14,400bps, applications
- UL1459 recognized
- CH1817-L: Low power consumption and Common mode noise rejection filter
- CH1817-LM (special order): Reduced transmit attenuation
- CH1817-D: Differential transmission input and 0dB transmission insertion loss.

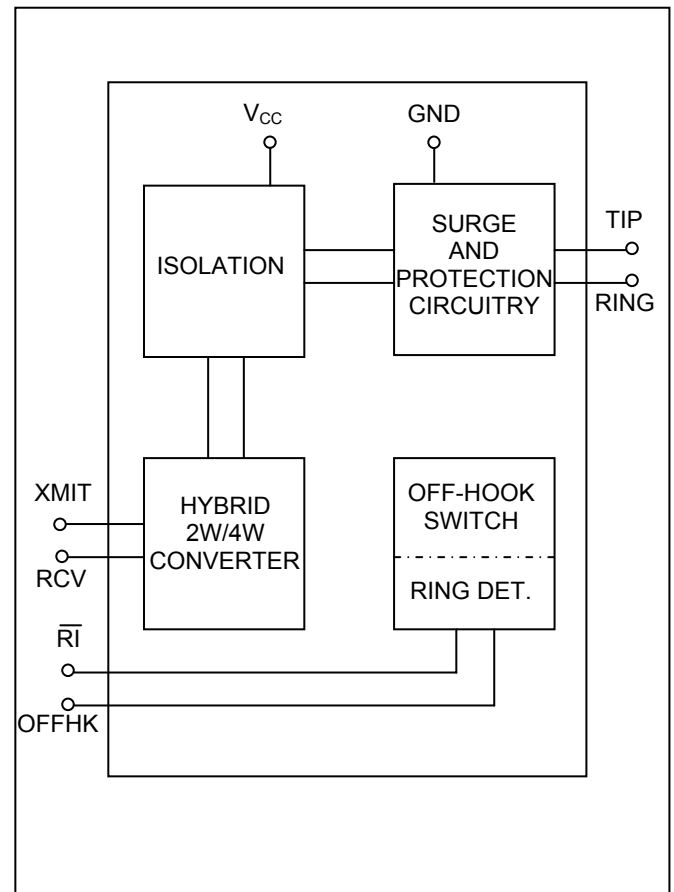

Figure 1. CH1817 DAA Functional Block Diagram.

**Hook Switch.** The OFFHK input is used to control the on-hook and off-hook status of the CH1817. When OFFHK is low, the CH1817 is in the On-Hook State. This indicates to the CO that the CH1817 is ready to receive calls. When OFFHK is high, the CH1817 allows the CO supplied loop current to flow, indicating either it is answering a call or preparing to place a call.

**OFFHK**

Input: Active High  
Active Current: 4mA

**2-Wire To 4-Wire Hybrid Converter.** This block has two functions:

1. It applies the XMIT signal to the phone line.
2. It subtracts the desired signal from the total outgoing signal on the phone line to derive the RCV signal.

The accuracy of this derivation depends on how closely the impedance of the phone line matches 600 Ohms. Generally, a small amount of the XMIT signal will appear at RCV. The ratio of the applied XMIT signal to the received XMIT signal is called Trans-Hybrid Rejection, or Trans-Hybrid Loss. On a 600Ω phone line, the CH1817 DAAs have very high trans-hybrid rejection, typically 23 dB.

**NOTE**

The FCC requires that the DTMF tone not exceed 0dBm.

**TRANSMIT SIGNAL**

The outgoing analog signal to be transmitted through the phone line should be applied to the XMIT pin (with respect to GND) and must be AC coupled as shown in Figure 2. For the CH1817-D a XMIT (+) and XMIT (-) pins provide a differential input. The CH1817-L attenuates the transmit signal by 9.5dB, 0dB for the -D option. Therefore, a transmit signal of 0dBm for the -L option (-9.5 dB for -D) applied to XMIT will comply with the FCC Part 68 requirement for data signals of -9dBm across TIP and RING.

**RECEIVE SIGNAL**

The incoming analog signal appearing between TIP and RING is presented at RCV with respect to GND and must be AC coupled to the user equipment receive input. The CH1817 does not gain the receive signal. Receive signals can vary from a maximum strength of -9dBm to below -50dBm.

**RCV**

Gain: 0dB  
Out impedance: 100Ω  
Typical Output Signal:  
-9dBm to -50dBm  
2.5Vrms to 0.27mVrms  
Signal referenced to GND  
AC coupling required

	<b>XMIT</b>			
	CH1817-D	CH1817-L	CH1817-DM	CH1817-LM
Attenuation	0dBm	9.5dBm	6.5dBm	6.5dBm
Input Impedance	150KΩ	150KΩ	150KΩ	150KΩ

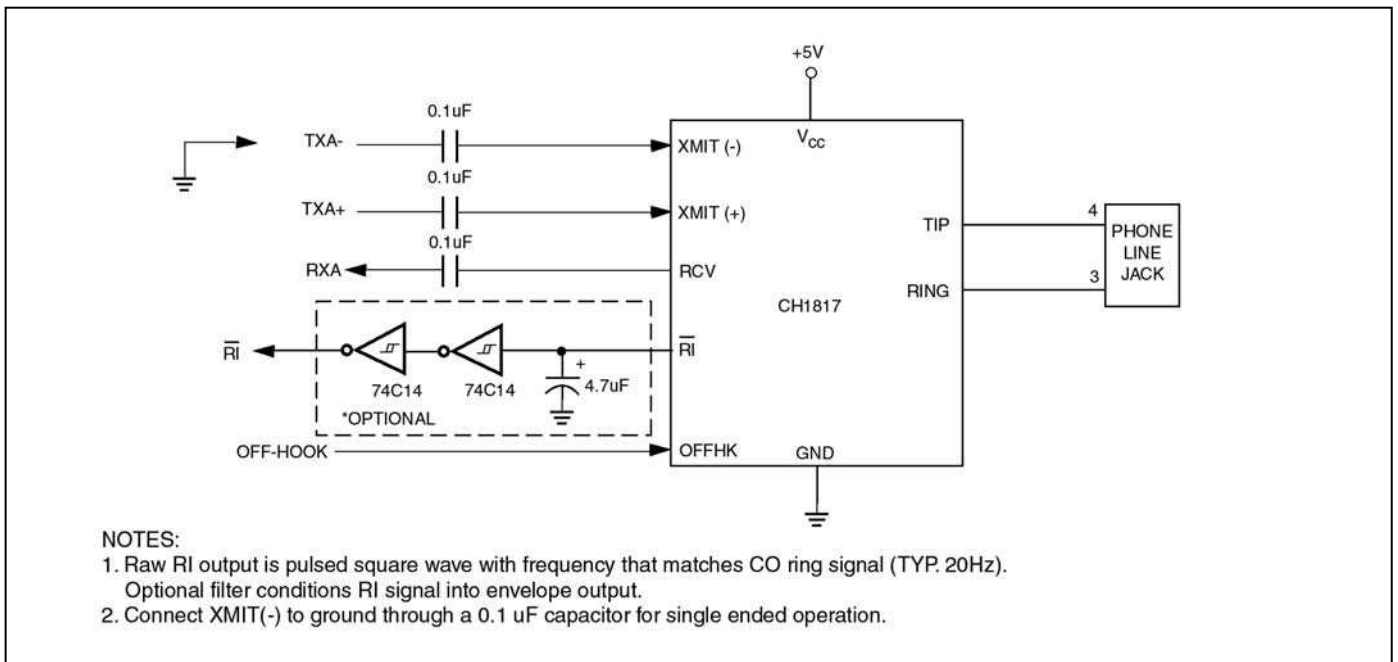

**Figure 2. Typical CH1817 Application.**

**Table 1. CH1817 Family Pin Description.**

Pin	Name	I/O	Function
1	TIP	I/O	<b>TIP.</b> Direct telephone line connection.
2	RING	I/O	<b>RING.</b> Direct telephone line connection.
3	OFFHK	I	<b>OFF HOOK.</b> When set LOW, the CH1817 is placed On-Hook. When set HIGH, the CH1817 is placed Off-Hook to answer or place a call. This input can also be used for pulse dialing. NOTE: When answering incoming calls in response to a ring indication on $\overline{RI}$ , internal relay contact degradation may occur if OFFHK is set HIGH before $\overline{RI}$ returns to its HIGH state.
4	$\overline{RI}$	O	<b>RING INDICATION.</b> It is asserted LOW by the CH1817 during the 2 second ON portion of the incoming AC Ring Signal and is asserted HIGH during the 4 second idle period between rings. An envelope of the AC ring signal may be created using the application circuit shown in Figure 2.
5	RCV	O	<b>RECEIVE.</b> This provides the signal or audio output with respect to ground and must be AC coupled with a 0.1 $\mu$ F capacitor to eliminate DC offset.
6	XMIT(-) or N/C	I or -	<b>TRANSMIT SIGNAL (-).</b> Input a differential AC coupled audio signal with respect to XMIT(+), CH1817-D versions only. All others, No Connection. For single ended operation of CH1817-D, connect this pin to ground through a 0.1 $\mu$ F capacitor.
7	VCC	I	<b>POWER SUPPLY.</b> +5V $\pm$ 5%
8	XMIT(+)	I	<b>TRANSMIT SIGNAL (+).</b> Input an AC coupled audio signal with respect to ground. Input a differential signal with respect to XMIT(-) for the CH1817-D versions only.
9	GND	I	<b>Ground.</b> Must be connected to signal ground. Note: Noise should be less than 25mV peak-to-peak.

### CH1817-L: LOW POWER

The L Family is a Low Power version of the CH1817 DAA. When Off-Hook, this DAA draws only 4mA through  $V_{CC}$ . When On-Hook, the L Family can be configured so that the Ring Detection circuit can be activated by a pull-up resistor on  $\overline{RI}$  while  $V_{CC}$  has been disconnected from the power supply, thus making the On-Hook power consumption virtually zero (See Figure 4).

### CH1817-D: 0 dB XMIT ATTENUATION

The D option has 0.0 dB insertion loss (typical) with respect to a differential input between XMIT (-) and XMIT (+). This allows the maximum signal strength of -9dBm to be input while maintaining FCC compliance. To use the CH1817-D as single end input device, ground the XMIT (-) pin through a 0.1uF capacitor.

### MOUNTING THE DAA

The DAA can be soldered directly to the host circuit card or installed in sockets. To avoid the problems of contamination, hand soldering is preferred to wave soldering. When hand cleaning use only deionized water; when wave soldering use washless flux.

### DESIGN CONSIDERATIONS

The CH1817 DAA includes circuits that couple the modem signals to the phone line and provides FCC required isolation and protection. The FCC registration process by the host product can be minimized provided that the following guidelines are followed.

1. The mounting of the DAA in the final assembly must be made so that it is isolated from exposure to any hazardous voltages within the assembly. Adequate separation and restraint of cables and cords must be provided.
2. Connection to the phone line should be made through a standard FCC approved RJ-11C jack or equivalent.
3. Circuit board traces from the DAA's TIP and RING pins must exceed 0.1 inch spacing from all other traces or other conducting material. The purpose for this spacing is to maintain 1000 VAC isolation between the phone line and the other traces. Traces should have a nominal width of 0.020 inches or greater.
4. TIP and RING traces should be as short as possible and should be oriented to prevent direct or induced coupling with other signals on the host circuit card.

5. The DAA Module is a sensitive subsystem that should be treated as any other integrated component. Pay special attention to the power supply to the DAA. The device handles signals in the millivolt range. Even though it is designed to handle noise in the power supply, steps should be taken to assure the noise level does not exceed 50mV peak-peak.
6. For data calls, Part 68 rules require silence on the phone line for at least 2 seconds after a data call has been completed to allow central offices to exchange billing information and specifies the transmit level must not exceed -9dBm. The FCC rules also require that for voice calls the final system meet the requirements of Part 68 for Out-of-Band Energy, and DTMF Transmit Levels. Because the CH1817 already meets FCC requirements for Part 68 registration for High Voltage isolation and Surge Protection, the certification of the product is normally a simple process that often can be completed directly with the FCC. If desired, independent testing labs are available that can test the system and submit the required paperwork to the FCC for approval. Cermetek can assist with the registration.
7. The CH1817 DAA as is meets or exceeds the hazardous voltage, surge and leakage requirements of the FCC. For applications that connect to Canadian phone lines, governed by the DOC (Department of Communications) and to further protect the CH1817 from field failure on excessively poor quality lines and to maintain UL recognition, a higher level of transient protection is required, thereby making mandatory the circuit consisting of two fuses and one varistor as shown in Figure 3. Adding these three devices will not affect FCC registration. Components L1, L2, C1, C2 are optional and serve two purposes. First, they restrict high frequency signals from reaching the phone line and thereby add EMI protection. Second, they protect against externally generated RFI from degrading the modem's ability to operate on proper carrier signals. Adding these devices will not affect FCC, DOC, or UL registration.

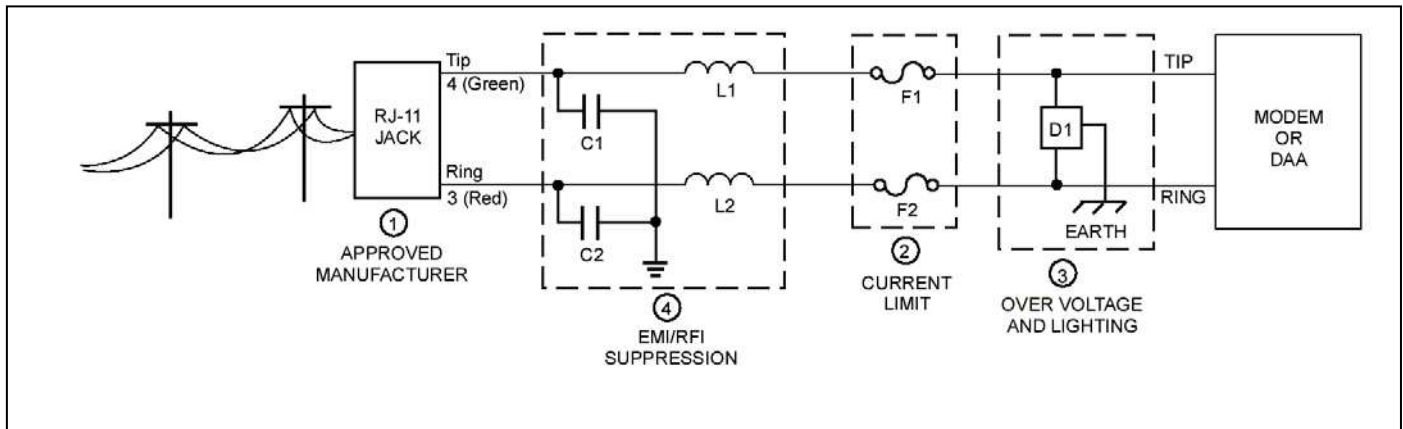

**Figure 3. Telephone Line Interface.**

1. RJ-11 Jacks must be provided by one of the vendors on the list. Refer to Application Note #130, Summary of Recommended Suppliers.
2. **Current Line Device: F1 and F2 – 1.25amp.**
  - A. UL 1459 must use a current limit device. A Poly Fuse is recommended as this device resets automatically after each power surge.
  - B. Resistors (10ohm carbon film or SMD 1/8W minimum) may be used for non UL applications.
3. **Over Voltage and Lightning Protection.**
  - A. DOC (Canada) may require external current limiting devices. Use 1ohm resistors (carbon film or SMD parts 1/8W minimum) in each lead (TIP and RING). You may substitute fuses or the Poly Fuse described in Section 2.
  - B. For lightning prone areas where there are more than 2 storms per year, provide an earth ground connection and use a three terminal sidactor or similar device that provides metallic and longitudinal protection. This must also include the current protection in Section 2.
4. **EMI/RFI Suppression.**  
The capacitor/ inductor network should be located as close to the RJ-11 Jack as possible with an excellent ground path to the chassis. Capacitors C1 and C2 should not exceed 0.005 $\mu$ F. They must have a rating of 1.5KV and typically have a value of 0.001 $\mu$ F  $\pm$  20%. Inductors L1 and L2 are ferrite cylinders and provide attenuation to high frequencies from system level components external to the CH1817. The required values must be empirically determined for each product design

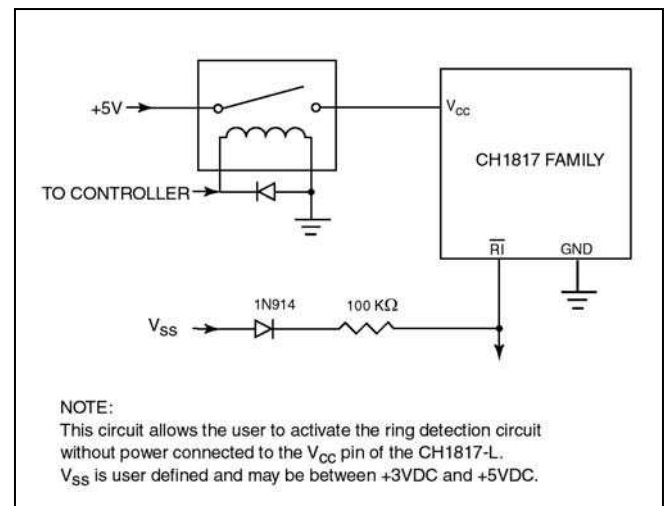

**Figure 4. Low Power Ring Detection.**

**Table 2. CH1817 DAA Electrical Specifications.**  
 $V_{CC}=+5VDC \pm 5\%$ ,  $T_A=0^\circ$  to  $55^\circ C$

Parameter	Conditions	Min.	Typ.	Max.	Units
Supply Current	Off-Hook		4	6	mA
	Off-Hook		0.6	1.5	mA
Transmission Insertion Loss	Attenuation between transmit input and telephone line at 1800Hz with 600Ohm termination:				
	CH1817-L measured XMIT(+) with respect to GND	9.0	9.5	10.0	dBm
	CH1817-DM measured XMIT(-) with respect to XMIT(+)	6.0	6.5	7.0	dBm
	CH1817-LM measured XMIT(+) with respect to GND	6.0	6.5	7.0	dBm
Receive Gain	CH1817-D measured XMIT(-) with respect to XMIT(+)	-0.5	0.0	0.5	dBm
	Gain between telephone line and receive output at 1800Hz with 600Ohm termination	-0.5	0.0	0.5	dBm
Telephone Line Input Impedance	At 1800Hz	550	600	650	Ohm
Trans-Hybrid Loss	Attenuation between the transmitter input and receiver output at 1800Hz with 600Ohm termination	18	23		dBm
Transmit Input Impedance	At 1800Hz	120	150	200	kOhm
Receive Output Impedance	At 1800Hz		100	1000	Ohm
Ring Detect Sensitivity	AC voltage between Tip and Ring	38			$V_{rms}$
Ringer Equivalency Number (REN)	Type "A"		0.2		A
Hook Switch Control Current			4		mA
Loop current		20		80	mA
Weight			10		gm

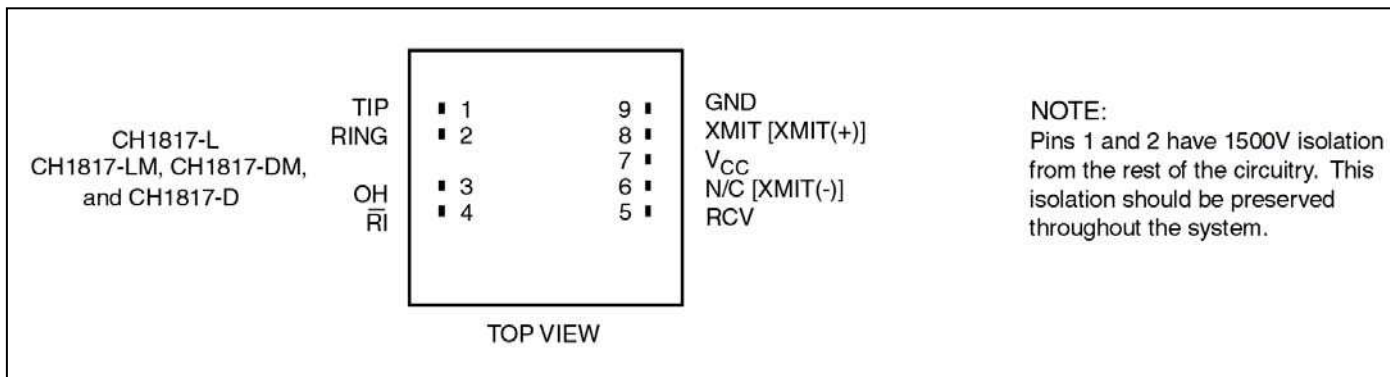

**Figure 6. Pin Connections.**

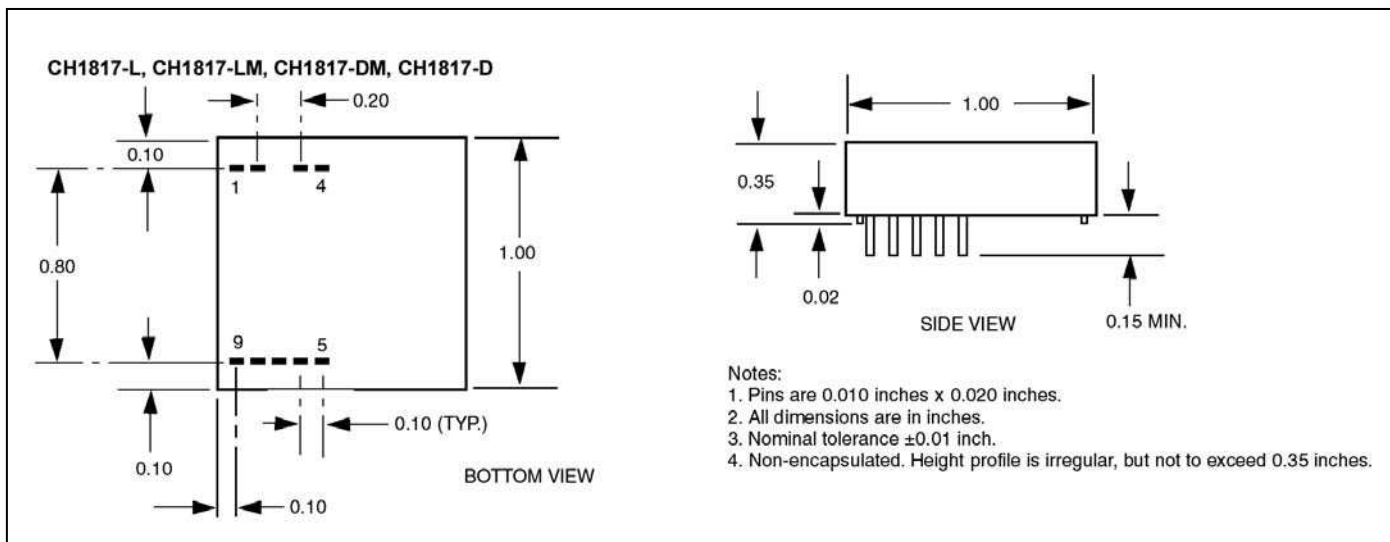

Figure 7. Mechanical Specifications.

Table 2. Product Family Summary.

Model	Summary of Features	Operating Temperature
CH1817D	UL1459 Listed, XMIT attenuated by 0.0dBm, Differential input	0°C to 55°C
CH1817L	UL1459 Listed, XMIT attenuated by 9.5dBm, Single ended input	0°C to 55°C
CH1817LM	UL1459 Listed, XMIT attenuated by 6.5dBm, Single ended input	0°C to 55°C
CH1817DM	UL1459 Listed, XMIT attenuated by 6.5dBm, Differential input	0°C to 55°C
CH1817ET*	UL1459 Listed, XMIT attenuated by 9.5dBm, Single ended input	-40°C to 85°C
CH1817LET*	UL1459 Listed, XMIT attenuated by 9.5dBm, Single ended input	-40°C to 85°C

\*Available upon special order only. Contact factory for details.

Cermetek reserves the right to make changes in specifications at any time and without notice. The information furnished by Cermetek in this publication is believed to be accurate and reliable. However, no responsibility is assumed by Cermetek for its use, or for any infringements of patents or other rights of third parties resulting from its use. No license is granted under any patents or patent rights of Cermetek.

Printed in U.S.A