



## 10/100BASE-TX DUAL-PORT DIGI-PHY™ TRANSCEIVER

### FEATURES

- Dual-port 10/100BASE-TX IEEE 802.3u Fast Ethernet transceiver
- Power consumption: <195 mW per port
- Unique energy detection circuit to enable intelligent power management
- HP auto-MDIX
- Robust CESD tolerance
- Cable length indication
- Cable noise level indication
- Cable length greater than 140 meters
- Well under 10 PPM defect ratio quality
- Industrial temperature range (-40 to 85C°)
- MII/7-wire serial interface
- IEEE 1149.1 (JTAG) scan chain support
- MII management via serial port
- 100-pin PQFP and 100-pin fpBGA package

### SUMMARY OF BENEFITS

- **Low power and intelligent power management**
  - Increase active working time
  - Prolong battery life in active standby
  - Increase reliability
- **Improved ease of use and installation, reduced support cost**
  - Straight-through or cross-over cables accommodate independent of installation
  - Resistance to CESD prevent product destruction and product returns
  - Advanced cable diagnostic features enable remote monitoring and debugging of cabling infrastructure
- **DSP-based Digi-PHY™ architecture ensures performance over temperature, voltage, and process variation**
  - Proven in over 450,000,000 Fast Ethernet ports
- **Provides ease of manufacturing with JTAG support**
- **Enables simplified system and board design with MAC interface and packaging options**

### Backplane Bus Communication 10/100BASE-TX Application

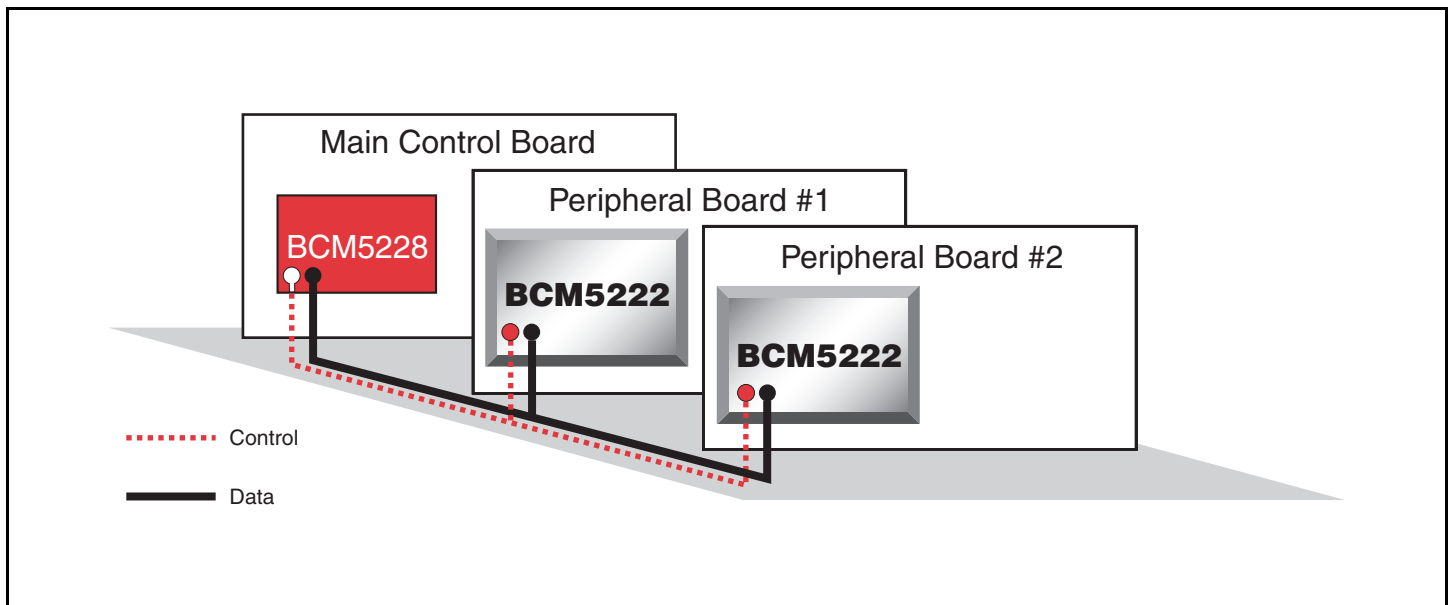

## OVERVIEW

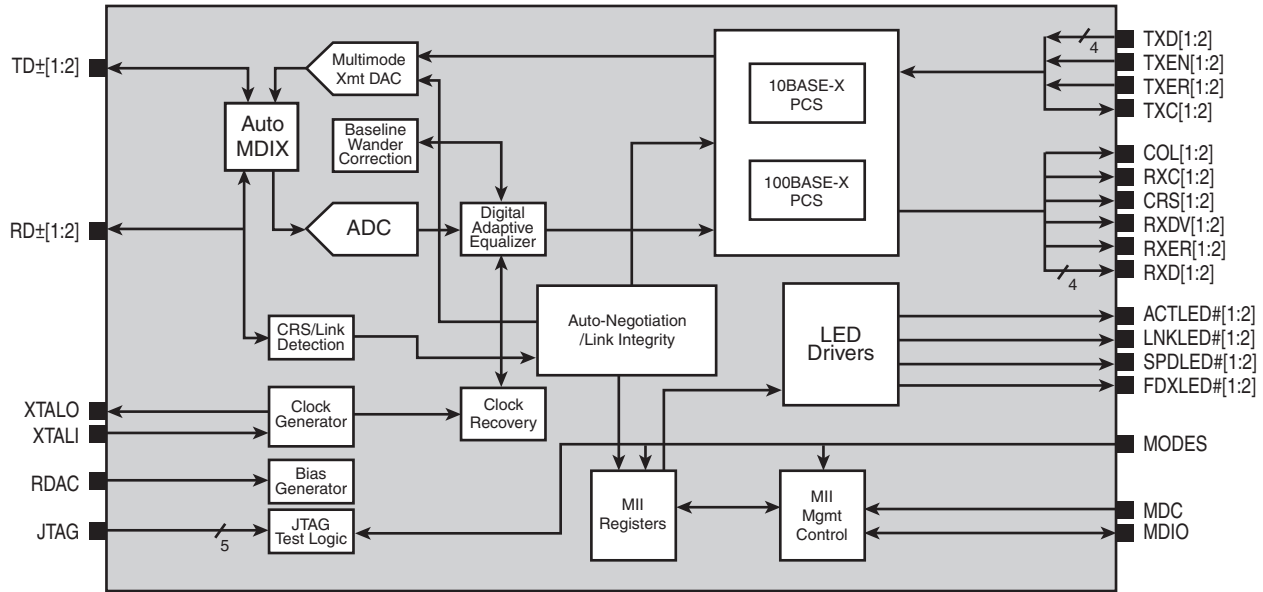

### Lowest-Power Fast Ethernet PHY

With a power dissipation of less than 195 mW per port, the BCM5222 is the industry's lowest-power Fast Ethernet PHY. In addition, the BCM5222 has several intelligent power-down states that conserve power, yet allow products based on it to automatically turn on when needed.

The BCM5222 includes a unique Intelligent Power-Management feature that powers down the device if energy is not detected on the cable. The energy detect feature is especially useful for portable and power-sensitive applications, as the BCM5222 draws virtually no energy if the cable is not plugged in and the client is not connected to the network. This results in noticeably extended battery life for portable applications, and increases product reliability due to decreased power dissipation. For lowest power consumption, the BCM5222 can be put in a power-off state (<2.0 mW).

### Network Tolerance

The BCM5222 includes features that simplify the installation and maintenance of local area networks. One such feature is the HP Auto-MDIX capability, which automatically detects and corrects crossed cables. With HP Auto-MDIX, the installer does not need to know what is on the other side of the network cable: the BCM5222 automatically

switches its transmit and receive circuitry to accommodate the link partner's polarity.

Cable-sourced electrostatic discharge (CESD) is a recently discovered phenomenon that occurs when an electrically charged network cable is plugged into a networked product, an issue becoming more prevalent with recent cable installations. The BCM5222 has been designed and tested to withstand over 9 KV of CESD, which unlike other transceivers, prevents the device from being destroyed in a CESD event.

### DSP-Based PHY Technology

The BCM5222 builds on Broadcom's proven DSP PHY design and full custom circuit design techniques to create a highly integrated and robust physical layer solution. DSP techniques allow the BCM5222 to achieve high interoperability and to exhibit robust performance across temperature (-40 to 85C°), voltage, and process variations. Broadcom's DSP-based, Digi-PHY™ technology has been proven in the shipment of over 450,000,000 Fast Ethernet ports. Broadcom's superior quality has resulted in a failure rate well under 10 PPM.

### Applications

- IP Phones
- Backplane Bus Communication
- Embedded Telecom
- Print Servers

Broadcom®, the pulse logo, and Connecting everything® are trademarks of Broadcom Corporation and/or its subsidiaries in the United States and certain other countries. All other trademarks mentioned are the property of their respective owners.

Connecting  
everything®



**BROADCOM CORPORATION**  
16215 Alton Parkway, P.O. Box 57013  
Irvine, California 92619-7013

© 2004 by BROADCOM CORPORATION. All rights reserved.

5222-PB05-R 07/01/04

Phone: 949-450-8700  
Fax: 949-450-8710  
E-mail: info@broadcom.com  
Web: www.broadcom.com