



PCI EXPRESS® TO PCI-X® I/O BRIDGE WITH INTEGRATED DUAL GIGABIT ETHERNET PORTS

FEATURES

- **Dual Gigabit Ethernet**
- **PCI Express® to PCI-X® bridge**
- **Dual integrated 1.25 Gbps SerDes interface**
- **Dual 1000BASE-X MACs**
- **Media Access Controller**
 - Integrated high-speed RISC cores
 - 56 KB receive and 22 KB transmit buffers
 - CPU task offload features (TCP, IP, UDP checksum, and Microsoft® Large Send Offload)
- **TCP segmentation, IP fragmentation, and reassembly**
- **Robust manageability**
 - PXE 2.0 remote boot
 - Universal Management Port interface for high-speed system management traffic
 - IPMI compliant server management interface
 - Out-of-Box Wake-on LAN (OOB WOL)
 - Statistic gathering (SNMP MIB II, Ethernet-like MIB, Ethernet MIB) (802.3x, clause 30)
 - Comprehensive diagnostic and configuration software suite
 - SMBus 2.0 controller

- **Power management, ACPI 1.1a compliant in multiple power modes**
- **Advanced Features**
 - Priority queuing—802.1p layer 2 priority encoding
 - Virtual LANs—802.1q VLAN tagging and support for up to 64 VLANs
 - Jumbo frames (9 KB)
 - 802.3x flow control
 - Link aggregation—802.3ad, GEC/FEC, and Smart Load Balancing
 - Failover
- **Performance features**
 - CPU task offload
 - Adaptive interrupts
 - PCI-X split transaction
 - Configurable, non-symmetric host interface access
- **484-pin PBGA package**
- **Power**
 - Rails—1.2V core, 2.5V I/O, and 3.3V I/O
 - Peak power dissipation of 5.0W
 - Average power dissipation of 3.0W

APPLICATIONS

- Highly integrated LAN on Motherboard (LOM) designs
- Blade Servers
- Rack Optimized Servers

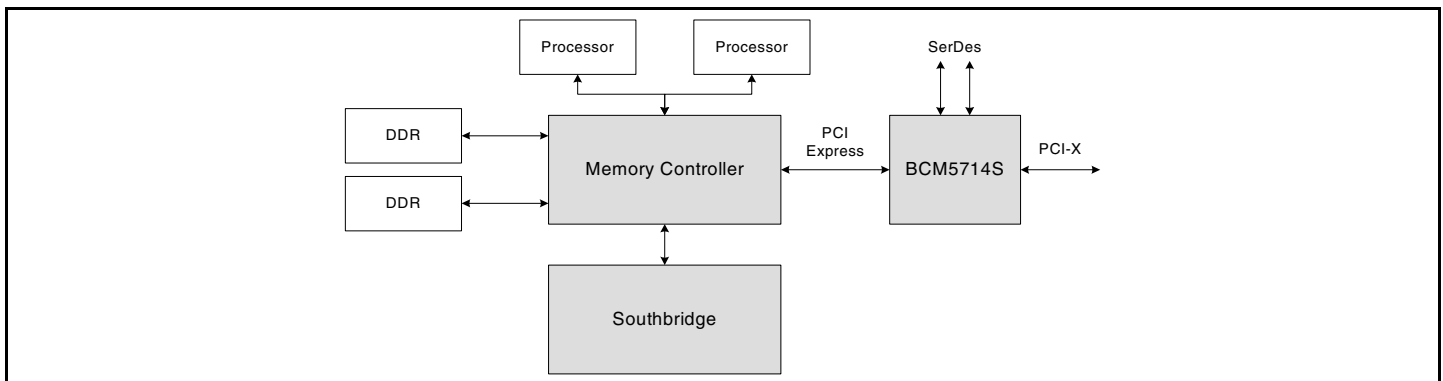

System Block Diagram

OVERVIEW

The BCM5714S device is a highly integrated communication and storage bridge for entry-level servers and embedded applications. The primary applications are UP and DP servers featuring PCI Express connectivity for I/O expansion.

The primary features of the BCM5714S are:

- Dual Gigabit NIC ports
- One full 64-bit/133-MHz PCI-X 1.0 bus
- Host interface of PCI Express
- Integrated SerDes

The BCM5714S connects to server chip sets with an x4 PCI Express interface and provides an independent PCI-X 1.0 bus for peripheral connectivity. The x4 PCI Express interface is a flexible design and supports x1 and x2 PCI Express connectivity as well. The PCI-X bus is 64 bits wide and runs at 133 MHz.

As an integrated I/O bridge that provides a high performance data flow path between the PCI-E host interface and the integrated I/O sub system, the PCI-X bus provides high-performance I/O expansion within the system, and the Gigabit Ethernet interfaces provide high performance network interfaces to the external world. The 64-bit PCI-X bus segment operates at 33 MHz, 66 MHz, 100 MHz, and 133 MHz. The Gigabit Ethernet Interface represents Broadcom's fourth generation of server controllers with fully integrated SerDes transceivers.

The PCI-X Bridge also has the following features:

- Allows concurrency between the PCI Express and the PCI-X buses
- Eight deep PCI Express-to-PCI-X memory write posting (PCI Express-to-PCI-X transactions)
- Four deep PCI Express-to-PCI-X non-posted request queue (PCI Express-to-PCI-X transactions)
- Caching with a 16-deep, 32-byte I/O cache for PCI to main memory transactions for each PCI bus
- Support write-through caching protocol
- Supports up to 14 outstanding split transactions (PCI-X-to-main memory transactions)
- Eight-deep PCI-X-to-PCI Express request queue (PCI-X-to-main memory transactions)
- Parity protection on the PCI-X bus in a conventional PCI and PCI-X mode1
- Optional ECC protection on the PCI-X bus in PCI-X mode1
- Three programmable regions each for PCI-X memory, and one region for I/O
- VGA-compatible addressing support
- Multiple I/O APIC support
- Peer-to-peer transfer support
- Integrated PCI-X bus arbitration that supports up to four PCI-X bus masters
- PCI-X bus error reporting
- RAS features

Broadcom[®], the pulse logo, **Connecting everything**[®], and the Connecting everything logo are among the trademarks of Broadcom Corporation and/or its affiliates in the United States, certain other countries and/or the EU. Any other trademarks or trade names mentioned are the property of their respective owners.

Connecting
everything[®]



BROADCOM CORPORATION

16215 Alton Parkway,
Irvine, California 92619-7013

© 2009 by BROADCOM CORPORATION. All rights reserved.

5714S-PB03-R 04/06/09

Phone: 949-450-8700
Fax: 949-450-8710
E-mail: info@broadcom.com
Web: www.broadcom.com