



BROADCOM'S NEW 65-NM "SMART" SWITCH ENABLES MASS DEPLOYMENT OF GIGABIT ETHERNET FOR THE CONSUMER MARKET

FEATURES

- **Highly integrated, 65-nanometer (nm) process, non-blocking 5-port 10/100/1000 switch silicon that integrates:**
 - Five 10/100/1000 PHYs.
 - Two fully integrated, GMII/RGMII/MII interfaces Inband Management Ports (IMP) for glueless connection to a CPU or WLAN.
- **Patented ease of use capabilities:**
 - LoopDTech™ technology provides loop detection without running spanning tree protocol (STP).
 - CableChecker™ enables advanced cable diagnostics based on the Broadcom® Convergence Algorithm.
- **Virtual Local-Area Network (VLAN)**
 - IEEE 802.1Q-based VLAN with 4K entries.
 - Port-based VLAN.
 - VLAN double tagging (Q-in-Q): Supports addition and removal of one or two tags and VLAN translation.
 - MAC-based VLAN.
- **Quality of Service (QoS)**
 - Four selectable QoS per port; SP and WRR and any combination of SP and WRR scheduling.
 - Port, MAC, IEEE 802.1P, and IPv4/IPv6 DSCP-based QoS.
- **Performance**
 - 9 KB jumbo frame support; wirespeed performance for all frame sizes.
 - 4K MAC addresses with automatic learning and aging.
 - 64 multicast group support.
 - 128-KB packet buffer.
 - Allows data packet inspection to be offloaded from a product's central processing unit (CPU), thereby freeing up CPU bandwidth to provide superior performance.
- **Security**
 - IEEE 802.1x support for secure user authentication.
 - DoS prevention hardware.
 - TCAM-based ACLs: 256 policy rules, rule-based filtering, and QoS class modification; rule-based metering and accounting; 128-byte deep packet header look-up, 28-byte matching.
- **Traffic control and network resiliency**
 - Storm control and port-based ingress/egress rate control.
 - Spanning Tree support (Rapid Spanning Tree and Multiple Spanning Trees—up to 16)
 - IPv4 IGMP and IPv6 MLD snooping
 - IEEE 802.3x programmable per-port flow control and backpressure
 - Port mirroring, LLDP, LACP

SUMMARY OF BENEFITS

- **Industry's first 65-nm 5-port Gigabit Ethernet (GbE) switch in a single chip enables ubiquitous deployment of GbE to consumer electronic devices and home networking equipment.**
- **Flexible solution enables cost-optimized consumer system designs that require scalable interfaces to address every facet of the consumer market segment.**
- **Broadcom-patented features provide unique and easy to use solutions to network loop and cable problems. LoopDTech automatically detects network debilitating loops, reducing system cost. CableChecker can be run at any time to detect cable length and problems without interrupting live traffic and keep consumers connected.**
- **VLAN feature insures proper layer 2 isolation and security.**
 - Double tagging enables carrier class devices.
 - MAC-based VLAN provides wireless AP security support.
- **Integrated QoS technology supports all types of consumer connections, including VoIP, video, audio, and data. Priority can be assigned each traffic type to ensure guaranteed delivery of time-sensitive packets and efficient use of network bandwidth.**
- **Performance enhanced architecture supports line rate data transfer to ensure consumer data (video, audio, pictures, and files) are sent at wirespeed.**
- **Increased network security that blocks unwanted access.**
 - Provides an easy way to troubleshoot security problems.
 - Provides enhanced network security and resiliency to keep the home network running efficiently.
- **Traffic control allows rate control which identifies and prioritizes different data packet types within the switch while simultaneously assigning voice packets a higher priority for outbound communications, in addition to Layer 2 and Layer 3 multicast table support for IPTV.**

OVERVIEW

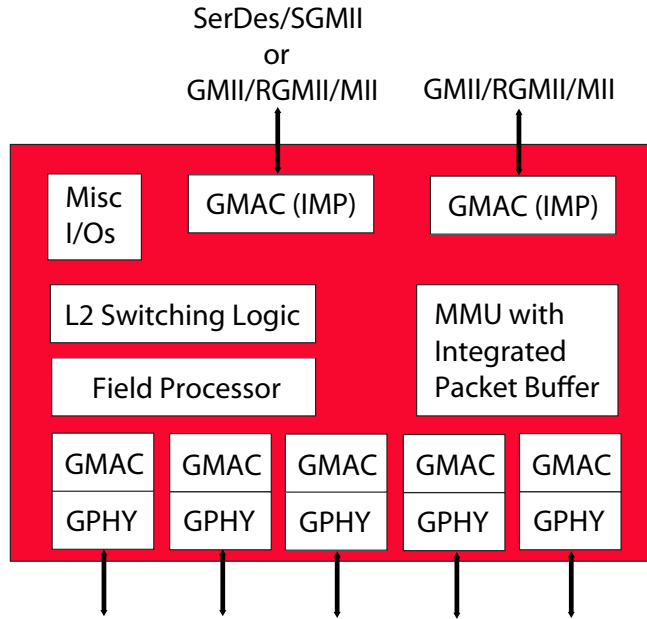

BCM53115M Block Diagram

The BCM53115 architecture is the optimal solution for consumer switching needs with its support for high-performance line rate capabilities and ability to identify and prioritize different data packet types within the switch while simultaneously assigning voice packets a higher priority for outbound communications. The BCM53115 is poised

to drive GbE into the unmanaged and Smart switch, WLAN router, and CPE/Gateway markets with its comprehensive Layer 2 feature set, support for both DSL/cable modem and WLAN connectivity, and an industry-leading 5 Gb of switching capacity—all on a single chip.

Features Supported

	<i>BCM53115M</i>	<i>BCM53115S</i>	<i>BCM53115U</i>
Number of Cu ports supported (five integrated GPHYs)	5	5	5
Number of additional IMP ports supported	2	2	0
Package (Commercial temperature)	17 x 17 (400-pin)	17 x 17 (400-pin)	17 x 17 (400-pin)
Package (Industrial temperature)	23 x 23 (484-pin)	23 x 23 (484-pin)	Not supported
CFP support	Yes	Not supported	Not supported
EAV	Yes	Not supported	Not supported
SmartPath software support	Yes	Yes	Not supported
FASTPATH [®] software support	Yes	Not supported	Not supported
ROHS support	Yes	Yes	Yes
Cable diagnostics tool support	Yes	Yes	Yes
LoopDTech tool support	Yes	Yes	Yes
Flexible LED scheme support	Yes	Yes	Not supported
Target applications and segments	CPE/Gateway	WLAN router, Smart switch	Unmanaged switch

Broadcom[®], the pulse logo, Connecting everything[®], the Connecting everything logo, LoopDTech[™], CableChecker[™], and FASTPATH are among the trademarks of Broadcom Corporation and/or its affiliates in the United States, certain other countries and/or the EU. Any other trademarks or trade names mentioned are the property of their respective owners.

Connecting
everything[®]



BROADCOM CORPORATION
5300 California Avenue
Irvine, California 92617

© 2007 by BROADCOM CORPORATION. All rights reserved.

53115-PB00-R 11/07/07

Phone: 949-926-5000
Fax: 949-926-5203
E-mail: info@broadcom.com
Web: www.broadcom.com