



AIRFORCE™ 2.4-GHZ 802.11A/B/54G™ WIRELESS LAN

REFERENCE DESIGN FEATURES

- **IEEE 802.11a/b/54g™ Mbps standard compliant and Wi-Fi CERTIFIED™** to ensure complete compatibility with 802.11a and 802.11b/g solutions and interoperability with over 800 products tested by the Wi-Fi alliance.
- **Low-power consumption** with a comprehensive power management technique. Optimized for new, low-power mobile processors, the BCM94309M consumes up to 75 percent less power than competing technologies for extended notebook battery life.
- **Maximum performance speed, reach, and security** with unique Broadcom® features such as SmartRadio™ and Xpress™ technology. Maximizes performance in presence of BlueTooth™ and other 2.4 GHz devices.
- **Low cost to manufacture** with standard CMOS processing, single-sided assembly, and direct conversion radio architecture that eliminates components. Optimized for DFM and DFT.
- **Fast time-to-market** with production quality board reference design package and complete suite of manufacturing test tools.
- **Simplified global distribution** with worldwide homologated design and single SKU that provides high performance connectivity worldwide.
- **Form factors** for a PC card and miniPCI with single-function or multi-function capability.
- **802.11a-only option** for 5 GHz-only modules.

AIRFORCE FAMILY FEATURES

- **Advanced high performance baseband processor with integrated medium access controller (MAC)** that supports future IEEE standards, such as 802.11i Security and 802.11e QoS for built-in future proof designs.
- **SmartRadio technology** improves wireless LAN throughput and range with advanced signal processing techniques. The all-CMOS solutions are capable of self-calibrating based on usage temperature and other environmental conditions, reconfiguring constantly for optimum performance.
- **OneDriver™** works with all AirForce™ 802.11a/b/54g solutions, simplifying the upgrade/update process for customers and end users. Driver certification and extensive operating system support, including WHQL certified Microsoft® Windows® drivers, Zero configuration with Microsoft XP, and embedded drivers for Linux® and VxWorks®.
- **Comprehensive security portfolio** including Cisco Compatible Extensions (CCX), Wi-Fi Protected Access (WPA) CERTIFIED, built-in hardware support for Advanced Encryption Standard (AES) protocol, Wired Equivalent Privacy (WEP) weak key avoidance, TKIP, and 802.1x.
- **Xpress technology** standards-based software enhancement. Increases aggregate network performance by up to 75 percent in a mixed 802.11a/b/54g+802.11b environment. 54g™-based client devices with Xpress technology can achieve more than six times greater performance than 802.11b products.
- **Worldwide regulatory capability** complying with DFS, TPC, passive scanning and radar detection requirements.

MP 802.11a/b/54g Mini PCI Reference Design

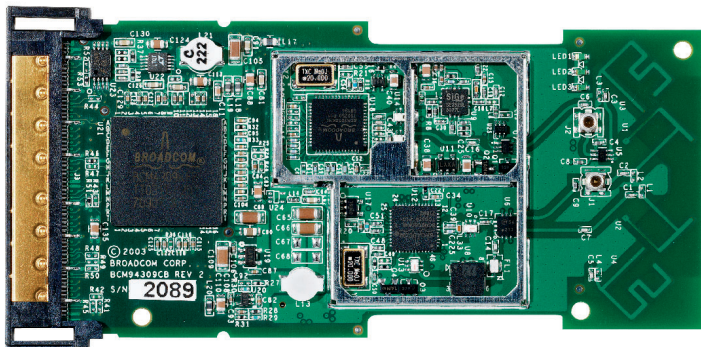

CB 802.11a/b/54g CardBus Reference Design

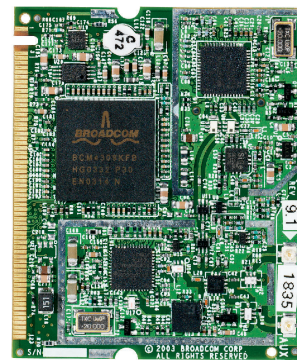

Single-Sided Design

OVERVIEW

BCM94309M Block Diagram

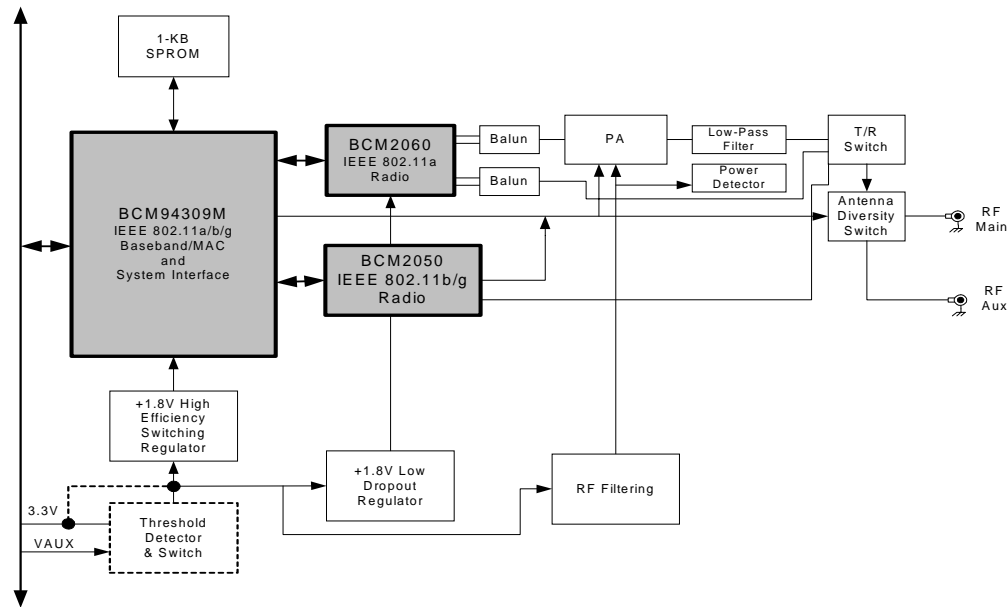

BCM94309M Specifications

Host interface: 32-bit card bus, PCI, mini PCI.	Range continued: 802.11b: 11 Mbps up to 180m LOS, 60m indoors; 1 Mbps up to 570m LOS, 125m indoors.
Network standard: IEEE 802.11a/b/g standards. IEEE 802.11h, 802.11d	Power consumption @ 3.3v: TX: 300 mA RX: 240 mA Power Save mode: ≤ 10 mA Radio disable: <10 mA
Data rate: 802.11b: 11 Mbps, 5.5 Mbps, 2 Mbps, 1 Mbps. 802.11a/g: 54 Mbps, 48 Mbps, 36 Mbps, 24 Mbps, 18 Mbps, 12 Mbps, 9 Mbps, 6 Mbps, 5.5 Mbps, 2 Mbps, and 1 Mbps.	Security: Hardware 64/128-bit WEP engine; WEP weak key avoidance; TKIP; hardware AES engine supporting CCM and OCB, WPA, 802.1x, and 802.11i.
Modulation: 802.11a/g: OFDM. 802.11b: CCK (11 Mbps, 5.5 Mbps), DQPSK (2 Mbps), and DBPSK (1 Mbps).	Delay tolerance: 802.11b: Multipath RMS delay spread @ 1% FER: 11 Mbps >250 ns, and 5.5 Mbps >300 ns
Network architectures: Infrastructure and ad hoc.	Client utility: Automatic location profile, site monitor, link status, and diagnostics.
Operating frequencies: 2.412–2.484 GHz. 4.900 GHz - 5.850 GHz	Software support: Microsoft WHQL certified for Windows XP, 2000, 98 SE, and ME.
Operating channels: 802.11b/g: 11 for North America, 13 for Europe (ETSI), 14 for Japan 802.11a: 12 channels for North America, 4 for Japan, 16 worldwide.	LED indicators: WLAN activity monitor, WLAN radio state indicators.
RF output power: 15 dBm maximum.	Switch: Manual radio on/off disables transmit and receive to comply with aviation inflight restrictions.
Antenna connectors: Hardware diversity support. Transmit and receive on main and auxiliary antenna connectors.	Temperatures: Operates from 0 to 70°C, and storage from -40 to 90°C.
Range: 802.11a/54g: 54 Mbps up to 50m Line of Sight (LOS), 20m indoors; 18 Mbps up to 150m LOS, 75m indoors.	Humidity (non-condensing): 5 to 95%
	Certifications: FCC part 15C/15.247; ETS 300 328-2; UL: IEC60950; EN 301 489-1,17; prEN50371; CE Mark; TELEC

Ordering Information

- BCM94309M CB (2.4-GHz Dual Mode CardBus Client Production Design).
- BCM94309M MP (2.4-GHz Dual Mode Mini PCI Client Production Design).
- Rev: September 2003. Specifications are subject to change without notice.

Broadcom[®], the pulse logo, Connecting everything[®], 54g[™], SmartRadio[™], Xpress[™], and OneDriver[™] are trademarks of Broadcom Corporation and/or its subsidiaries in the United States and certain other countries. Bluetooth[™] is a trademark owned by Bluetooth SIG. All other trademarks mentioned are the property of their respective owners.

Connecting
everything[®]



BROADCOM CORPORATION
16215 Alton Parkway, P.O. Box 57013
Irvine, California 92619-7013

© 2003 by BROADCOM CORPORATION. All rights reserved.

94309M-PB00-R 11/11/03

Phone: 949-450-8700
Fax: 949-450-8710
E-mail: info@broadcom.com
Web: www.broadcom.com