

DRIVER-AMPLIFIER GaAs MMIC

■GENERAL DESCRIPTION

NJG1308F is a GaAs MMIC Driver-Amplifier for 800MHz-1.9 GHz band of Cellular phone System.

It features a low current consumption and a high gain.
Small MTP6 package is adopted.

■PACKAGE OUTLINE

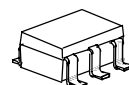

NJG1308F

■FEATURES

- Low supply voltage operation +3.0V typ.
- Low current consumption 15mA typ. @ $P_{out}=+8dBm$
- High gain 18dB typ. @ $f=938MHz$
16dB @ $f=1441MHz$
14dB @ $f=1900MHz$
- P_{out} at 1dB Gain Compression point +12dBm typ. @ $f=938MHz$
+11dBm typ. @ $f=1441/1900MHz$
- Package MTP6

■PIN CONFIGURATION

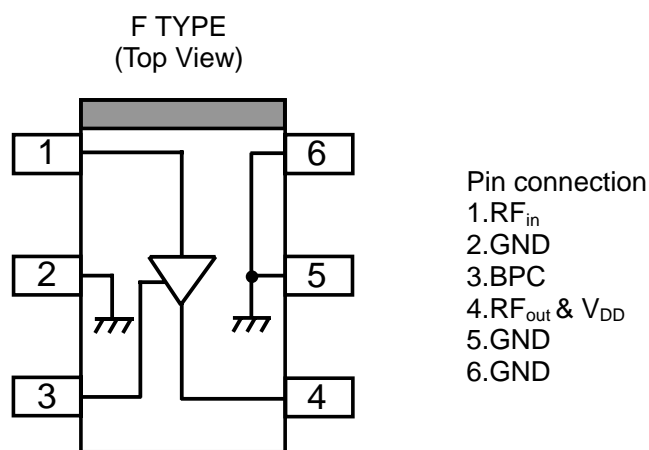

Note: is a package orientation mark.

NJG1308F

■ABSOLUTE MAXIMUM RATINGS

($T_a=+25^{\circ}\text{C}$, $Z_s=Z_l=50\Omega$)

PARAMETER	SYMBOL	CONDITIONS	RATINGS	UNITS
Drain Voltage	V_{DD}		6	V
Input Power	P_{in}	$V_{DD}=3V$	15	dBm
Power Dissipation	P_D		300	mW
Operating Temperature	T_{opr}		-40~+85	$^{\circ}\text{C}$
Storage Temperature	T_{stg}		-55~+150	$^{\circ}\text{C}$

■ELECTRICAL CHARACTERISTICS 1 (Application circuit 1)

($T_a=+25^{\circ}\text{C}$, $Z_s=Z_l=50\Omega$)

PARAMETER	SYMBOL	CONDITIONS	MIN	TYP	MAX	UNITS
Operating Frequency	Freq	$V_{DD}=3.0V$	915	938	960	MHz
Drain Voltage	V_{DD}		2.7	3.0	5.0	V
Operating Current	I_{DD}	$V_{DD}=3.0V$, $P_{out}=+8\text{dBm}$	-	15	21	mA
Small Signal Gain	Gain	$V_{DD}=3.0V$, $P_{in}=-10\text{dBm}$	15	18	21	dB
Gain Flatness	G_{flat}	$V_{DD}=3.0V$, $P_{in}=-10\text{dBm}$	-	0.5	-	dB
Pout at 1dB Gain Compression point	$P_{-1\text{dB}}$	$V_{DD}=3.0V$	-	+12	-	dBm
Adjacent Channel Leakage Power (PDC Regulation)	P_{acc}	$V_{DD}=3.0V$, $P_{out}=+8\text{dBm}$ offset=50kHz $P_{in}; \pi/4$ DQPSK	-	-60	-	dBc
Input VSWR	$VSWR_i$	$V_{DD}=3.0V$	-	1.5	-	
Output VSWR	$VSWR_o$	$V_{DD}=3.0V$	-	1.5	-	

■ELECTRICAL CHARACTERISTICS 2 (Application circuit 2)

($T_a=+25^{\circ}\text{C}$, $Z_s=Z_l=50\Omega$)

PARAMETER	SYMBOL	CONDITIONS	MIN	TYP	MAX	UNITS
Operating Frequency	freq	$V_{DD}=3.0V$	1429	1441	1453	MHz
Drain Voltage	V_{DD}		2.7	3.0	5.0	V
Operating Current	I_{DD}	$V_{DD}=3.0V$, $P_{out}=+8\text{dBm}$	-	15	21	mA
Small Signal Gain	Gain	$V_{DD}=3.0V$, $P_{in}=-10\text{dBm}$	13	16	19	dB
Gain Flatness	G_{flat}	$V_{DD}=3.0V$, $P_{in}=-10\text{dBm}$	-	0.5	-	dB
Pout at 1dB Gain Compression point	$P_{-1\text{dB}}$	$V_{DD}=3.0V$	-	+11	-	dBm
Adjacent Channel Leakage Power (PDC Regulation)	P_{acc}	$V_{DD}=3.0V$, $P_{out}=+8\text{dBm}$ offset=50kHz $P_{in}; \pi/4$ DQPSK	-	-60	-	dBc
Input VSWR	$VSWR_i$	$V_{DD}=3.0V$	-	1.5	-	
Output VSWR	$VSWR_o$	$V_{DD}=3.0V$	-	1.5	-	

■ELECTRICAL CHARACTERISTICS 3 (Application circuit 3)

($T_a=+25^{\circ}\text{C}$, $Z_s=Z_l=50\Omega$)

PARAMETER	SYMBOL	CONDITIONS	MIN	TYP	MAX	UNITS
Operating Frequency	freq	$V_{DD}=3.0\text{V}$	1890	1900	1920	MHz
Drain Voltage	V_{DD}		2.7	3.0	5.0	V
Operating Current	I_{DD}	$V_{DD}=3.0\text{V}$, $P_{out}=+8\text{dBm}$	-	15	21	mA
Small Signal Gain	Gain	$V_{DD}=3.0\text{V}$, $P_{in}=-10\text{dBm}$	11	14	17	dB
Gain Flatness	G_{flat}	$V_{DD}=3.0\text{V}$, $P_{in}=-10\text{dBm}$	-	0.5	-	dB
Pout at 1dB Gain Compression point	P_{-1dB}	$V_{DD}=3.0\text{V}$	-	+11	-	dBm
Adjacent Channel Leakage Power (PHS Regulation)	P_{acp}	$V_{DD}=3.0\text{V}$, $P_{out}=+8\text{dBm}$ offset=600kHz P_{in} : $\pi/4$ DQPSK	-	-60	-	dBc
Input VSWR	$VSWR_i$	$V_{DD}=3.0\text{V}$	-	1.5	-	
Output VSWR	$VSWR_o$	$V_{DD}=3.0\text{V}$	-	1.5	-	

■ELECTRICAL CHARACTERISTICS 4 (Application circuit 4)

($T_a=+25^{\circ}\text{C}$, $Z_s=Z_l=50\Omega$)

PARAMETER	SYMBOL	CONDITIONS	MIN	TYP	MAX	UNITS
Operating Frequency	freq	$V_{DD}=3.0\text{V}$	1750	1765	1780	MHz
Supply Voltage	V_{DD}		2.7	3.0	5.0	V
Operating Current	I_{DD}	$V_{DD}=3.0\text{V}$, $P_{out}=+8\text{dBm}$	-	15	-	mA
Power Gain	Gain	$V_{DD}=3.0\text{V}$, $P_{in}=-10\text{dBm}$	-	14	-	dB
Gain Flatness	G_{flat}	$V_{DD}=3.0\text{V}$, $P_{in}=-10\text{dBm}$	-	0.5	-	dB
Pout at 1dB Compression point	P_{-1Db}	$V_{DD}=3.0\text{V}$	-	+11	-	dBm
Input VSWR	$VSWR_i$	$V_{DD}=3.0\text{V}$	-	1.5	-	
Output VSWR	$VSWR_o$	$V_{DD}=3.0\text{V}$	-	1.5	-	

NJG1308F

■TERMINAL INFORMATION

No.	SYMBOL	DESCRIPTIONS
1	RF _{in}	RF signal input terminal of driver amplifier.
2	GND	Ground terminal.
3	BPC	Source electrode terminal of driver amplifier. The operating current is chosen by a resistor connected between this terminal and ground.
4	RF _{out} & V _{DD}	RF signal output terminal of driver amplifier. Please use choke coil for power supply of driver amplifier at this terminal.
5	GND	Ground terminal.
6	GND	Ground terminal.

TYPICAL CHARACTERISTICS 1 (Application circuit 1)

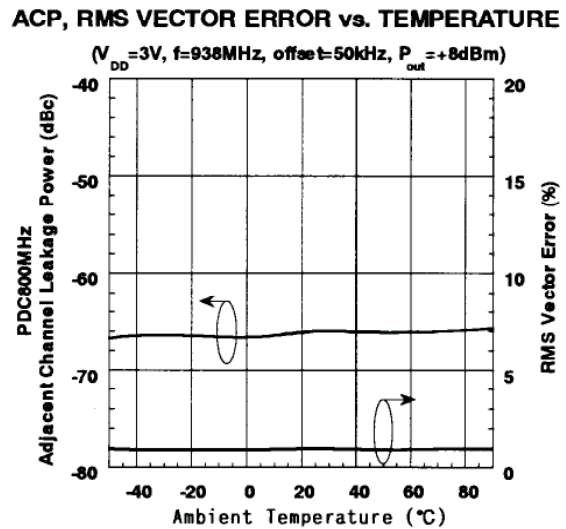
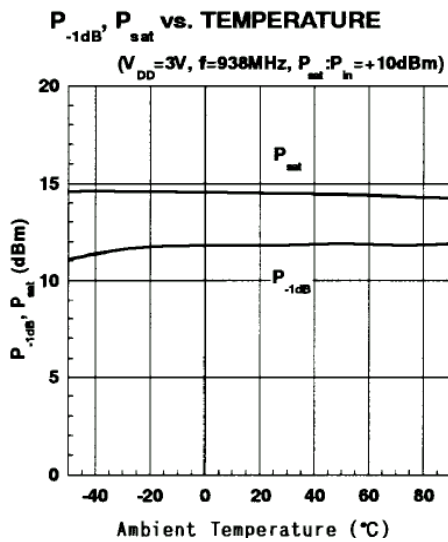
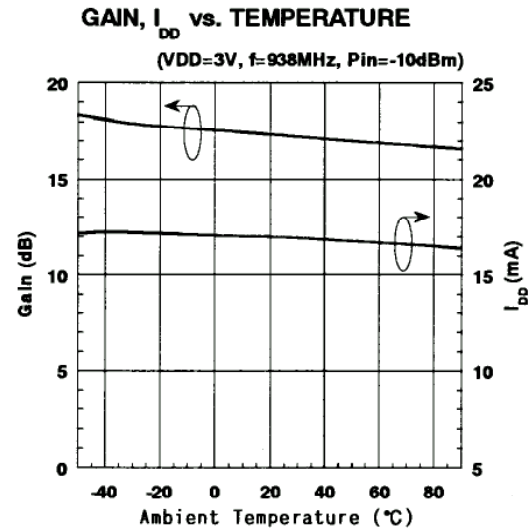
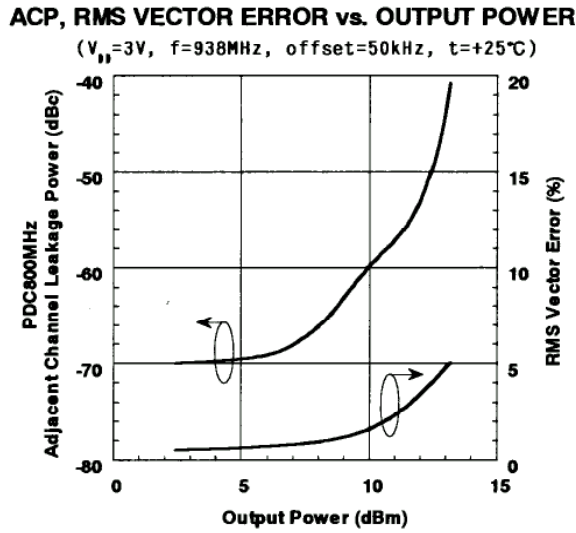
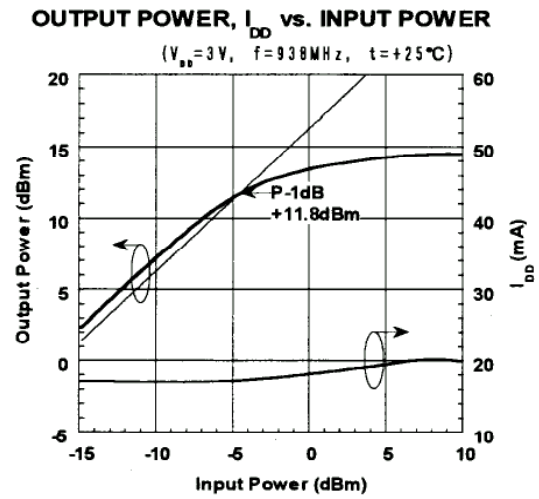
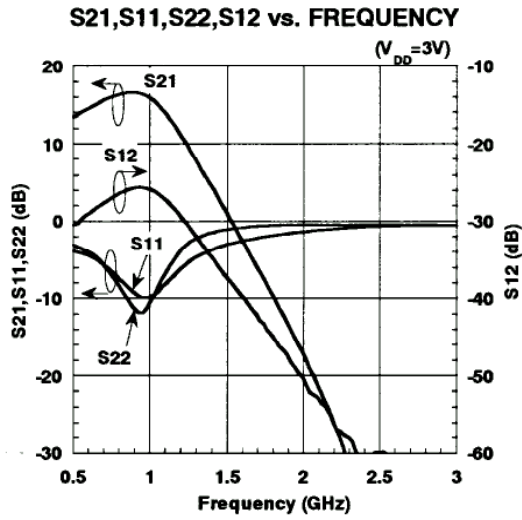

NJG1308F

TYPICAL CHARACTERISTICS 2 (Application circuit 2)

S21,S11,S22,S12 vs. FREQUENCY

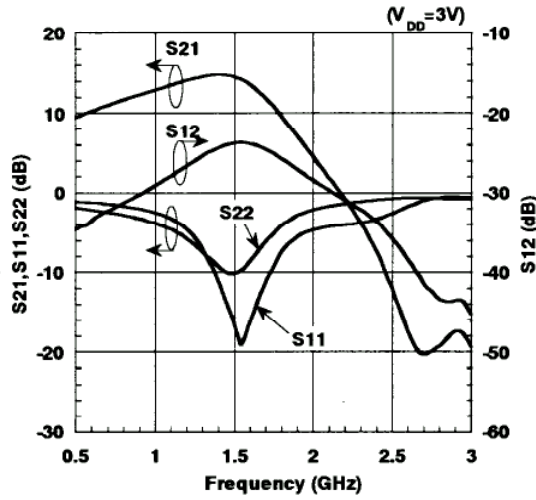

OUTPUT POWER, I_{DD} vs. INPUT POWER

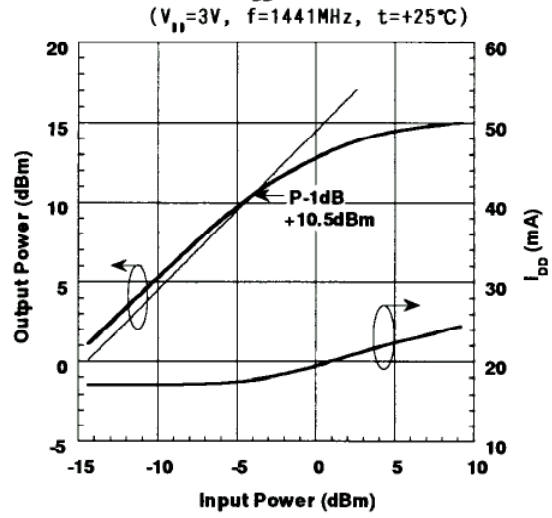

ACP, RMS VECTOR ERROR vs. OUTPUT POWER

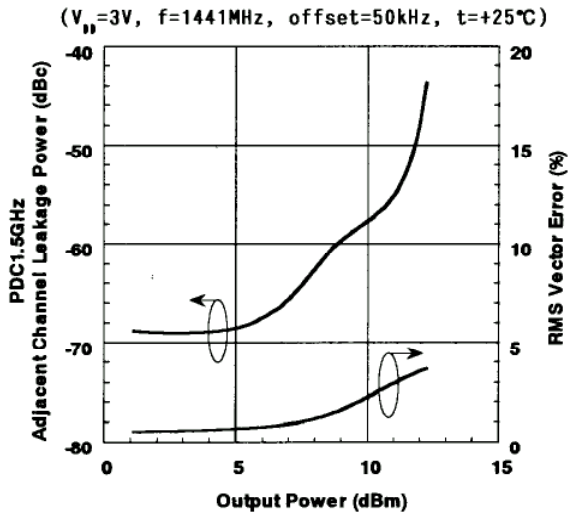

GAIN, I_{DD} vs. TEMPERATURE

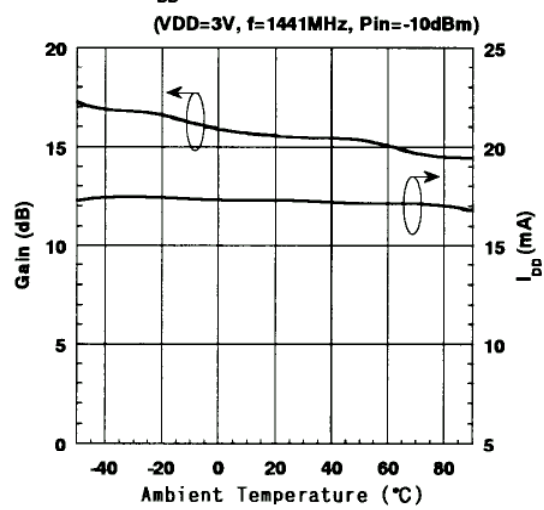

P_{-1dB}, P_{sat} vs. TEMPERATURE

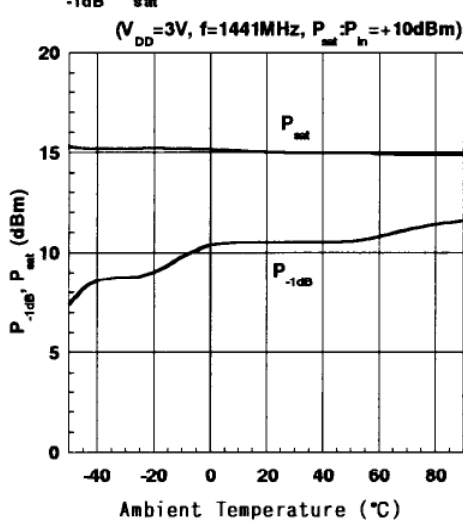

ACP, RMS VECTOR ERROR vs. TEMPERATURE

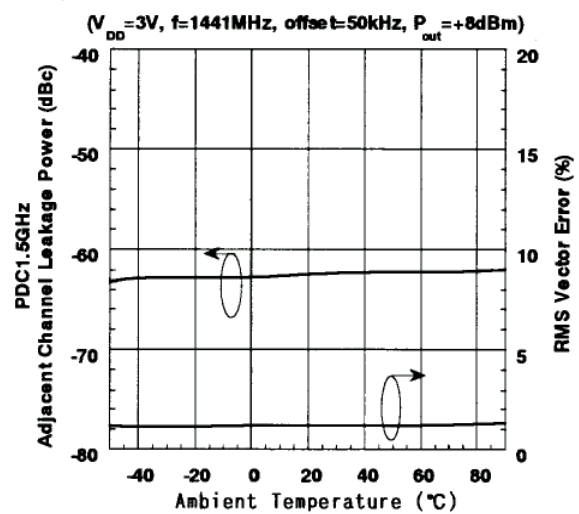

TYPICAL CHARACTERISTICS 3 (Application circuit 3)

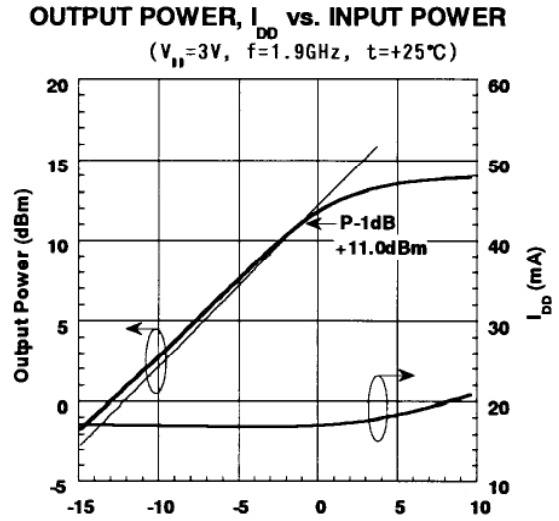
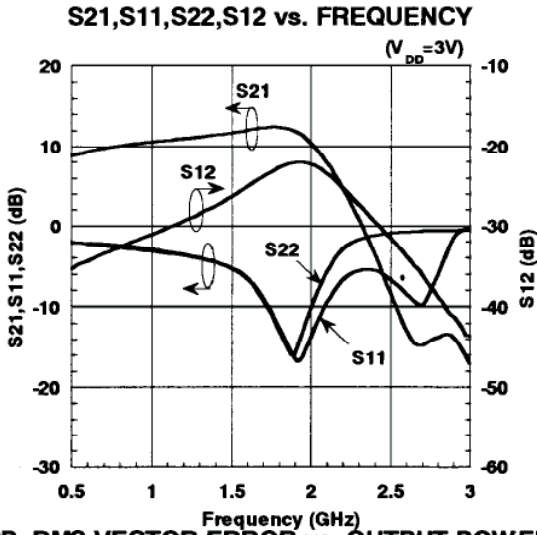

ACP, RMS VECTOR ERROR vs. OUTPUT POWER
($V_{DD}=3V, f=1.9GHz, \text{offset}=600kHz, t=+25^{\circ}C$)

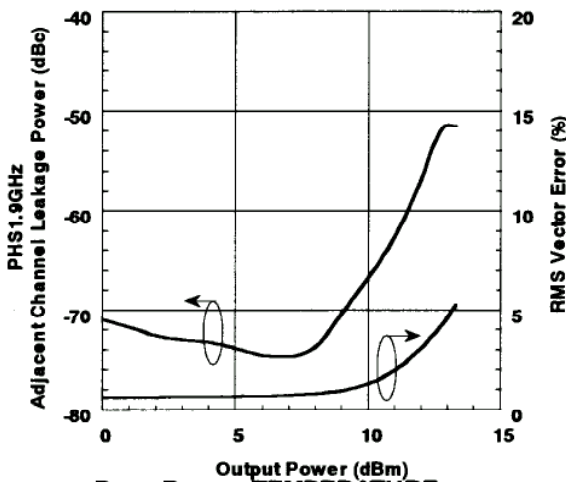

GAIN, I_{DD} vs. TEMPERATURE
($V_{DD}=3V, f=1.9GHz, P_{in}=-10dBm$)

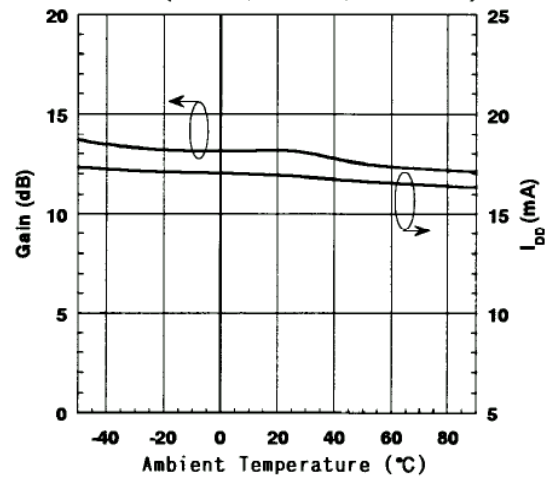

P_{-1dB}, P_{sat} vs. TEMPERATURE
($V_{DD}=3V, f=1.9GHz, P_{sat}:P_{in}=+10dBm$)

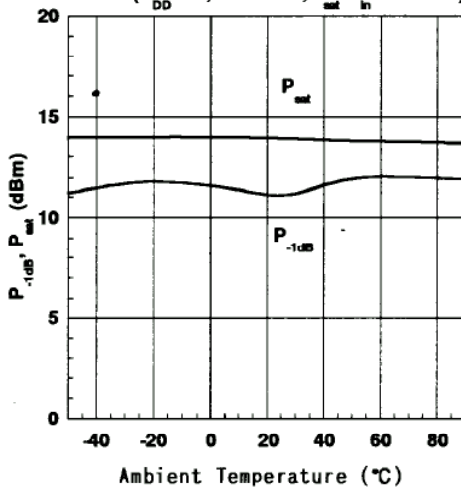

ACP, RMS VECTOR ERROR vs. TEMPERATURE
($V_{DD}=3V, f=1.9GHz, \text{offset}=600kHz, P_{out}=+8dBm$)

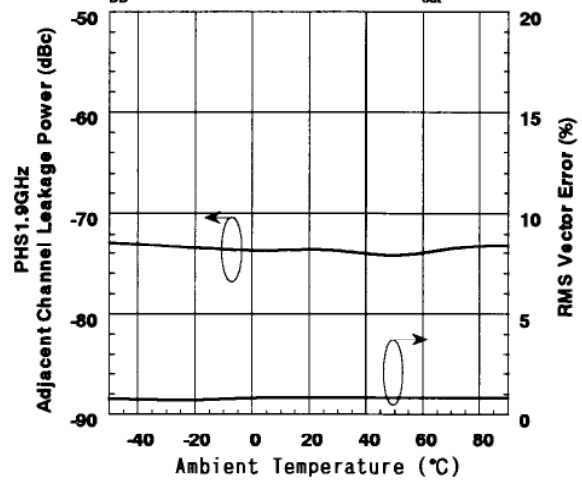

NJG1308F

■ TYPICAL CHARACTERISTICS 4 (Application circuit 4)

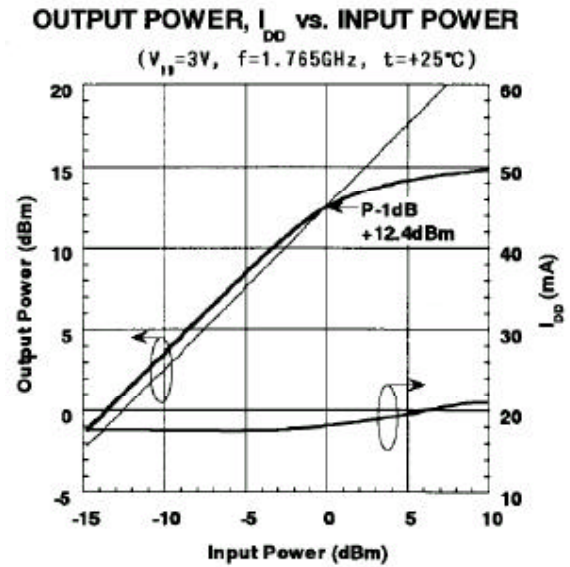
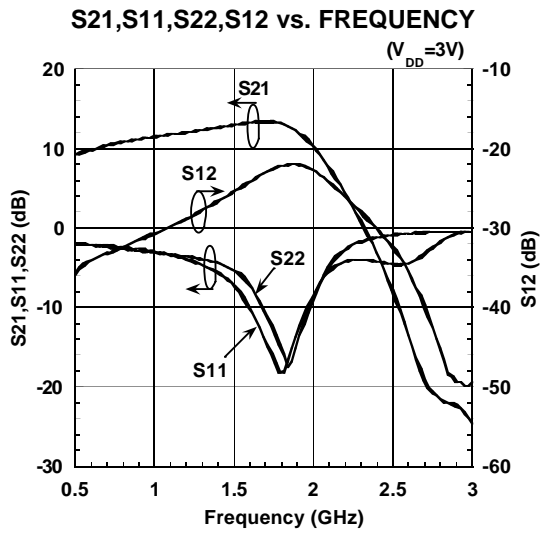

TYPICAL CHARACTERISTICS

Scattering Parameters ($V_{DD}=3V$)

Freq. (GHz)	S 11		S 21		S 12		S 22	
	mag (U)	ang (deg)	mag (U)	ang (deg)	mag (U)	ang (deg)	mag (U)	ang (deg)
0.50	0.865	-26.1	4.892	174.0	0.029	52.0	0.718	-56.5
0.60	0.853	-32.2	5.060	163.2	0.030	48.7	0.681	-63.4
0.70	0.834	-38.2	5.093	152.9	0.033	46.2	0.648	-69.6
0.80	0.810	-43.7	5.046	143.5	0.035	46.4	0.626	-74.9
0.90	0.788	-48.5	4.974	134.5	0.036	44.5	0.603	-78.8
1.00	0.757	-52.8	4.801	126.4	0.038	43.5	0.590	-82.4
1.10	0.729	-56.7	4.650	118.6	0.039	42.7	0.580	-85.6
1.20	0.700	-60.3	4.457	111.5	0.041	44.0	0.579	-88.8
1.30	0.672	-63.1	4.271	104.6	0.043	43.3	0.577	-90.9
1.40	0.645	-65.6	4.083	98.0	0.045	44.6	0.581	-93.6
1.50	0.618	-67.7	3.893	91.3	0.046	44.0	0.588	-96.0
1.60	0.589	-69.0	3.687	85.2	0.049	43.8	0.597	-98.5
1.70	0.563	-69.7	3.509	79.3	0.051	42.4	0.612	-100.8
1.80	0.541	-69.8	3.317	72.9	0.055	40.3	0.630	-103.7
1.90	0.519	-69.6	3.122	66.5	0.058	38.3	0.650	-106.9
2.00	0.502	-67.9	2.904	60.0	0.060	35.8	0.671	-110.2
2.10	0.489	-65.9	2.696	53.6	0.063	31.4	0.700	-114.5
2.20	0.490	-62.3	2.432	46.6	0.065	25.7	0.728	-119.5
2.30	0.502	-58.9	2.150	39.1	0.065	17.4	0.764	-125.8
2.40	0.536	-55.6	1.814	31.9	0.066	8.5	0.795	-132.8
2.50	0.592	-53.5	1.409	24.6	0.062	-5.9	0.828	-142.1
2.60	0.669	-53.8	0.933	21.3	0.056	-24.0	0.846	-153.2
2.70	0.760	-56.9	0.461	41.1	0.050	-54.3	0.842	-166.5
2.80	0.851	-62.8	0.575	106.1	0.048	-96.7	0.800	178.6
2.90	0.920	-70.6	1.154	113.3	0.060	-140.4	0.731	161.6
3.00	0.951	-79.2	1.703	105.2	0.081	-172.8	0.624	144.2

PIN CONNECTIONS AND FUNCTIONAL BLOCK DIAGRAM

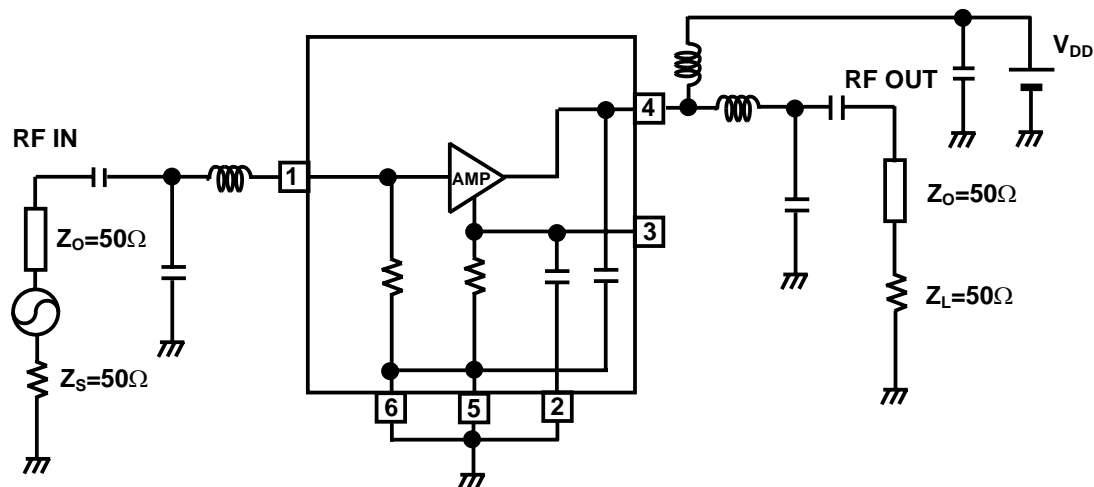

NJG1308F

APPLICATION CIRCUIT 1

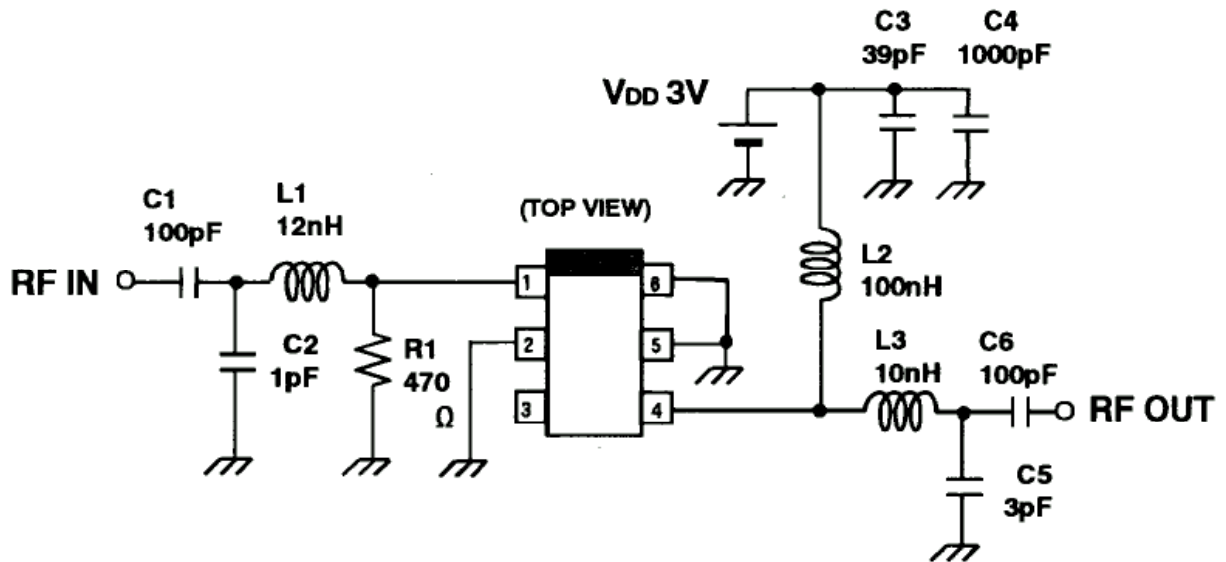

APPLICATION CIRCUIT 2

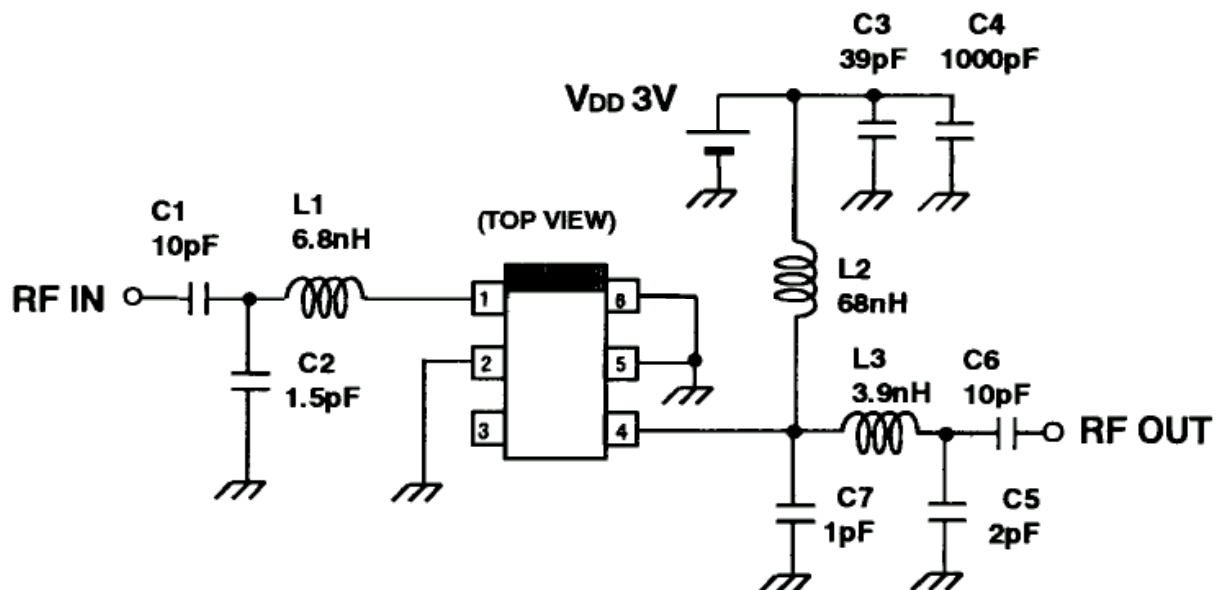

APPLICATION CIRCUIT 3

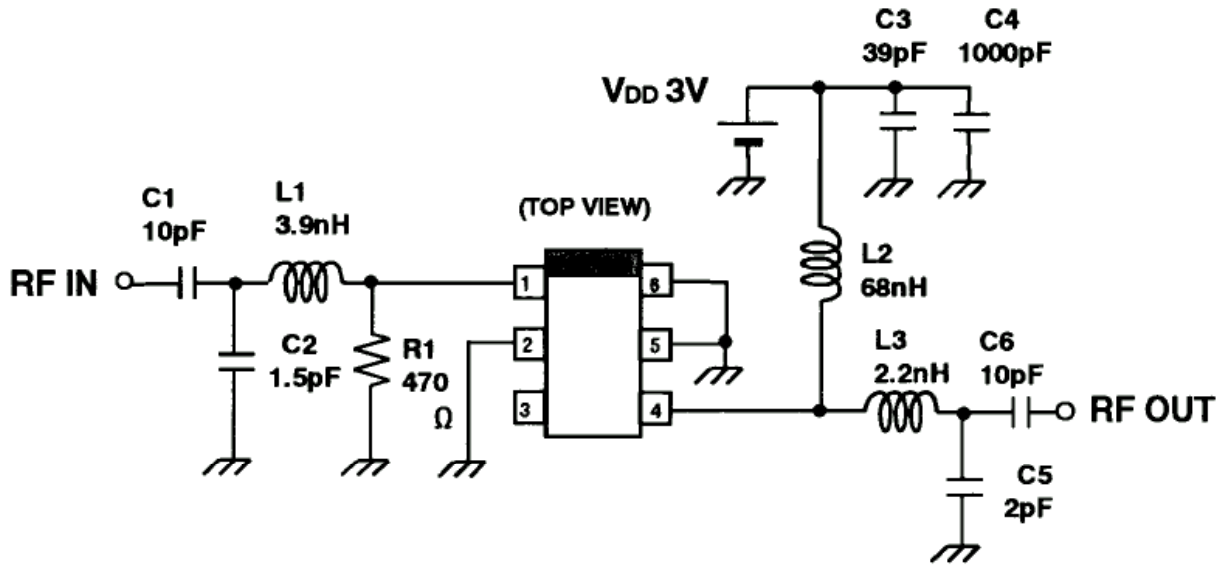

APPLICATION CIRCUIT 4

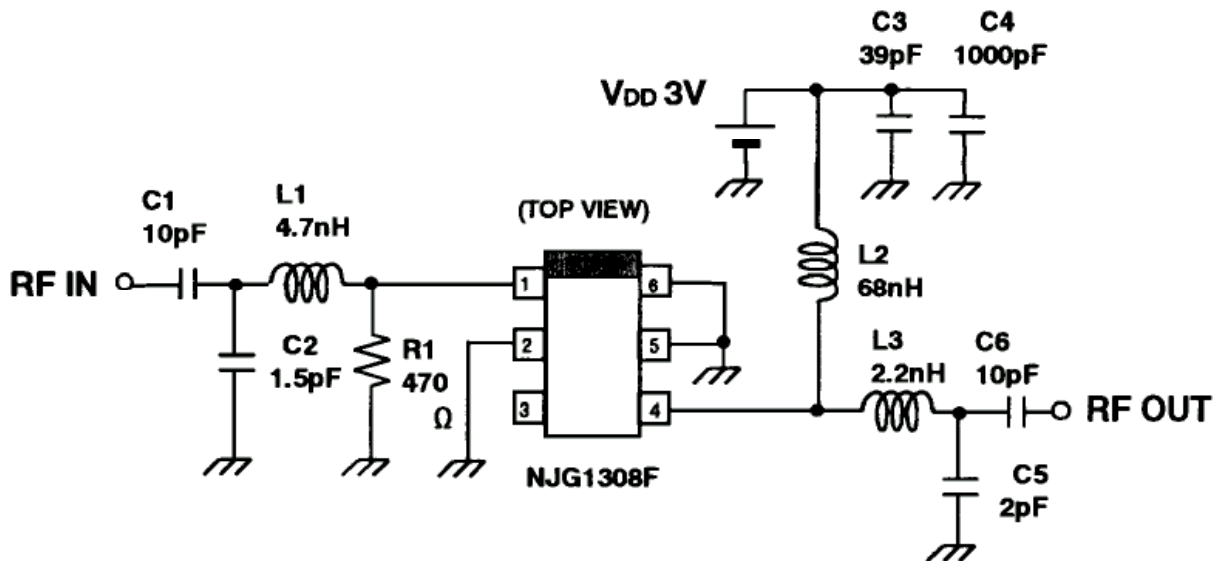

NJG1308F

RECOMMENDED PCB DESIGN

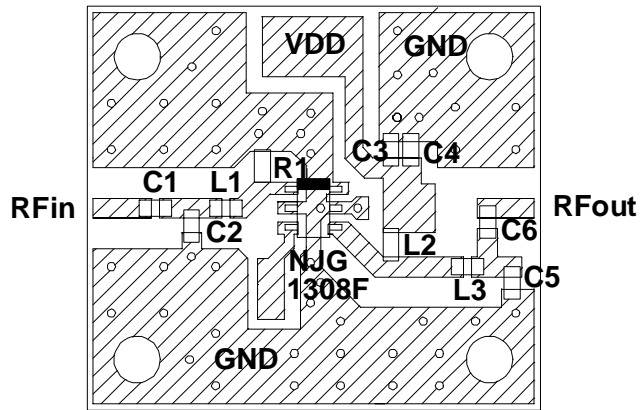

PCB:FR-4 22.5x20.0mm, t=0.5mm
 MICROSTRIP LINE WIDTH=1.0mm ($Z_0=50\Omega$)
 CHIP SIZE:1608

Notes:

[1] Following chip capacitor should be connected near to each terminal as bypass capacitor.

- (1) C3
- (2) C4

[2] Following chip capacitors are necessary to block DC bias.

- (3) C1
- (4) C6

[3] Chip parts list.

Parts ID	Comment
C1~C6	MURATA GRM39 Series
L1~L3	TAIYO-YUDEN HK1608 Series

PACKAGE OUTLINE (MTP6)

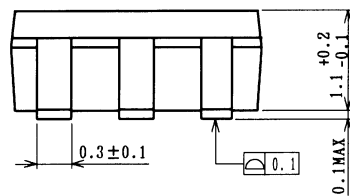
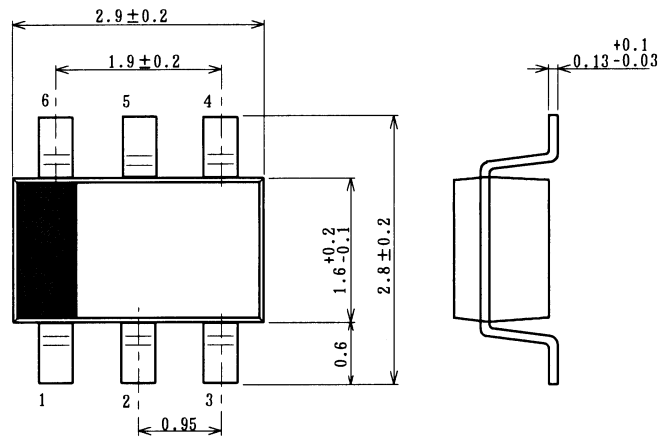

Lead material	: Copper
Lead surface finish	: Solder plating
Molding material	: Epoxy resin
UNIT	: mm
Weight	: 14mg

Cautions on using this product

This product contains Gallium-Arsenide (GaAs) which is a harmful material.

- Do NOT eat or put into mouth.
- Do NOT dispose in fire or break up this product.
- Do NOT chemically make gas or powder with this product.
- To waste this product, please obey the relating law of your country.

[CAUTION]

The specifications on this databook are only given for information, without any guarantee as regards either mistakes or omissions. The application circuits in this databook are described only to show representative usages of the product and not intended for the guarantee or permission of any right including the industrial rights.

This product may be damaged with electric static discharge (ESD) or spike voltage. Please handle with care to avoid these damages.