

## GSM900/GSM1800/CDMA800/CDMA1900 ANTENNA SWITCH GaAs MMIC (SP6T)

### ■ GENERAL DESCRIPTION

NJG1634LK5 is a GaAs SP6T antenna switch IC for GSM900/GSM1800/CDMA800/CDMA1900 handsets.

This switch IC features low harmonics, high IIP3 and low insertion loss.

This IC contains a MMIC switch die with on-chip logic circuits and a LTCC substrate with built-in two-LPFs on GSM transmit paths for suppression of transmitter harmonics.

The NJG1634LK5 features its very low height in size in spite of the use of LTCC.

### ■ PACKAGE OUTLINE

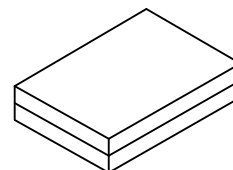

NJG1634LK5

### ■ FEATURES

- Low harmonics
  - 80/-75dBc typ. On GSM900 Tx @2fo/3fo, fo=915MHz, Pin=+35dBm, V<sub>DD</sub>=2.7V
  - 85/-80dBc typ. On GSM1800 Tx @2fo/3fo, fo=1785MHz, Pin=+32dBm, V<sub>DD</sub>=2.7V
- High IIP3
  - +68dBm typ. On CDMA800 @f=829+849MHz, Pin=+24dBm, V<sub>DD</sub>=2.7V
  - +68dBm typ. On CDMA1900 @f=1870+1910MHz, Pin=+24dBm, V<sub>DD</sub>=2.7V
- Low insertion loss
  - 0.80dB typ. On GSM900 Tx @f=915MHz, Pin=+35dBm, V<sub>DD</sub>=2.7V
  - 1.10dB typ. On GSM1800 Tx @f=1785MHz, Pin=+32dBm, V<sub>DD</sub>=2.7V
  - 0.60dB typ. On CDMA800 @f=849MHz, Pin=+27dBm, V<sub>DD</sub>=2.7V
  - 0.70dB typ. On CDMA1900 @f=1910MHz, Pin=+27dBm, V<sub>DD</sub>=2.7V
- Built-in two LPFs
  - Attenuation 35 / 31 dB typ. On GSM900 Tx @2fo / 3fo
  - Attenuation 35 / 35 dB typ. On GSM1800 Tx @2fo / 3fo
- Low height Package LCSP16-K5 (Package size: 4.5x3.2x1.0mm)

### ■ PIN CONFIGURATION

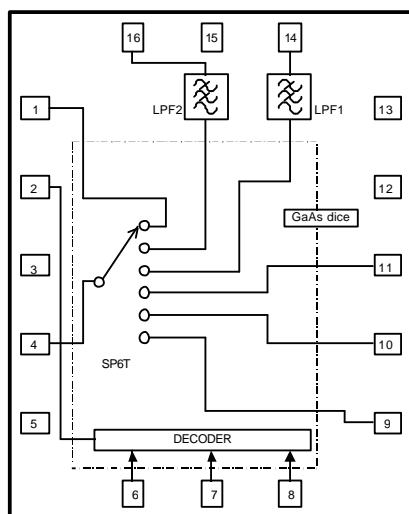

#### PIN CONNECTION

1. CDMA1900
2. VDD
3. GND
4. ANT
5. GND
6. CTL\_A
7. CTL\_B
8. CTL\_C
9. GSM1800 TX
10. GSM900 RX
11. CDMA800
12. N/C
13. GND
14. GSM1800 TX
15. GND
16. GSM900 TX

**NOTE:** Please note that any data or drawing in this catalog is subject to change.

# NJG1634LK5

---

## ■ TRUTH TABLE

"H"= $V_{CTL(H)}$ , "L"= $V_{CTL(L)}$

On Path	CTL A	CTL B	CTL C	VDD
GSM900 Tx	H	H	L	H
GSM900 Rx	L	H	H	H
CDMA800	L	H	L	H
GSM1800 Tx	H	L	L	H
GSM1800 Rx	L	L	H	H
CDMA1900	H	L	H	H
Idle	X	X	X	L

X: Do not care

## ■ ABSOLUTE MAXIMUM RATINGS

( $T_a=+25^{\circ}\text{C}$ ,  $Z_s=Z_l=50\Omega$ )

PARAMETER	SYMBOL	CONDITIONS		DUTY CYCLE	RATINGS	UNITS
RF Input Power	Pin	Antenna Port	100kHz~12.75GHz	CW	28.0	dBm
		EGSM Tx	880MHz~915MHz	4 : 8	36.0	dBm
		DCS Tx	1710MHz~1785MHz	4 : 8	36.0	dBm
		Cellular CDMA	824MHz~894MHz	CW	34.0	dBm
		PCS CDMA	1850MHz~1990MHz	CW	34.0	dBm
		All Rx port	100kHz~12.75GHz	CW	28.0	dBm
Supply Voltage	$V_{DD}$	$V_{DD}$ terminal			5	V
Control Voltage	$V_{CTL}$	$V_{CTL(L)}=0V$ , $V_{CTL(H)}=2.7V$			5	V
Power Dissipation	$P_D$				600	mW
Operating Temperature	$T_{opr}$				-40~+85	$^{\circ}\text{C}$
Storage Temperature	$T_{stg}$				-55~+150	$^{\circ}\text{C}$

## ■ ELECTRICAL CHARACTERISTICS 1 (DC)

( $T_a=+25^{\circ}\text{C}$ ,  $Z_s=Z_l=50\Omega$ )

PARAMETER	SYMBOL	CONDITIONS	MIN	TYP	MAX	UNITS
Supply Voltage	VDD		2.5	2.7	3.6	V
Control Voltage	VCTL(H)		2.0	2.7	VDD	V
	VCTL(L)		0	-	0.4	V

# NJG1634LK5

## ■ ELECTRICAL CHARACTERISTICS 2 (GSM900 Tx ON mode)

(General conditions:  $T_a=+25^{\circ}\text{C}$ ,  $Z_s=Z_l=50\Omega$ ,  $V_{DD}=2.7\text{V}$ ,  $V_{CTL(L)}=0\text{V}$ ,  $V_{CTL(H)}=2.7\text{V}$ )

PARAMETER	SYMBOL	CONDITIONS	MIN	TYP	MAX	UNITS
Frequency Range 1	$f_{\text{GSM900 Tx}}$	GSM900 Tx Band	880	-	915	MHz
Current Consumption 1	IDD1	Pin=35dBm at GSM900 Tx Port	-	400	700	$\mu\text{A}$
Insertion Loss 1	LOSS1	GSM900 Tx – ANT, $f_{\text{GSM900 Tx}}$ , Pin=35dBm	-	0.8	1.2	dB
Isolation 1	ISL1	GSM900 Tx to GSM900 Rx, $f_{\text{GSM900 Tx}}$ , Pin=35dBm	40	50	-	dB
Isolation 2	ISL2	GSM900 Tx to GSM1800 Rx, $f_{\text{GSM900 Tx}}$ , Pin=35dBm	35	45	-	dB
Isolation 3	ISL3	GSM900 Tx to CDMA800, $f_{\text{GSM900 Tx}}$ , Pin=35 dBm	35	40	-	dB
Isolation 4	ISL4	GSM900 Tx to CDMA1900, $f_{\text{GSM900 Tx}}$ , Pin=35 dBm	25	35	-	dB
VSWR 1	VSWR1	ANT port, $f_{\text{GSM900 Tx}}$	-	1.1	2.0	
VSWR 2	VSWR2	GSM900 port, $f_{\text{GSM900 Tx}}$	-	1.1	2.0	
2nd Harmonic Suppression 1	2HS(1)	GSM900 Tx to ANT, $2 \times f_{\text{GSM900 Tx}}$	30	35	-	dB
3rd Harmonic Suppression 1	3HS(1)	GSM900 Tx to ANT, $3 \times f_{\text{GSM900 Tx}}$	26	31	-	dB
2nd Harmonics 1	$2f_o(1)$	$f_o = f_{\text{GSM900 Tx}}$ , Pin=35dBm	-	-80	-70	dBc
3rd Harmonics 1	$3f_o(1)$	$f_o = f_{\text{GSM900 Tx}}$ , Pin=35dBm	-	-75	-70	dBc

## ■ ELECTRICAL CHARACTERISTICS 3 (GSM900 Rx ON mode)

(General conditions:  $T_a=+25^{\circ}\text{C}$ ,  $Z_s=Z_l=50\Omega$ ,  $V_{DD}=2.7\text{V}$ ,  $V_{CTL(L)}=0\text{V}$ ,  $V_{CTL(H)}=2.7\text{V}$ )

PARAMETER	SYMBOL	CONDITIONS	MIN	TYP	MAX	UNITS
Frequency Range 2	$f_{\text{GSM900 Rx}}$	GSM900 Rx Band	925	-	960	MHz
Current Consumption 2	IDD2	Pin=10dBm	-	400	700	$\mu\text{A}$
Insertion Loss 2	LOSS2	GSM900 Rx - ANT, $f_{\text{GSM900 Rx}}$	-	0.8	1.1	dB
Isolation 5	ISL5	GSM900 Tx to ANT, $f_{\text{GSM900 Tx}}$	33	43	-	dB
VSWR 3	VSWR3	ANT port, $f_{\text{GSM900 Rx}}$	-	1.6	2.0	
VSWR 4	VSWR4	GSM900 Rx port, $f_{\text{GSM900 Rx}}$	-	1.6	2.0	

## ■ ELECTRICAL CHARACTERISTICS 4 (GSM1800 Tx ON mode)

(General conditions:  $T_a=+25^{\circ}\text{C}$ ,  $Z_s=Z_i=50\Omega$ ,  $VDD=2.7\text{V}$ ,  $VCTL(L)=0\text{V}$ ,  $VCTL(H)=2.7\text{V}$ )

PARAMETER	SYMBOL	CONDITIONS	MIN	TYP	MAX	UNITS
Frequency Range 3	$f_{\text{GSM1800 Tx}}$	GSM1800 Tx Band	1710	-	1785	MHz
Current Consumption 3	IDD3	Pin=32dBm	-	400	700	$\mu\text{A}$
Insertion Loss 3	LOSS3	GSM1800 Tx - ANT $f_{\text{GSM1800 Tx}}$ , Pin=32dBm	-	1.1	1.4	dB
Isolation 6	ISL6	GSM1800 Tx to GSM900 Rx $f_{\text{GSM1800 Tx}}$ , Pin=32dBm	25	35	-	dB
Isolation 7	ISL7	GSM1800 Tx to GSM1800 Rx $f_{\text{GSM1800 Tx}}$ , Pin=32dBm	40	50	-	dB
Isolation 8	ISL8	GSM1800 Tx to CDMA800 $f_{\text{GSM1800 Tx}}$ , Pin=32dBm	20	27	-	dB
Isolation 9	ISL9	GSM1800 Tx to CDMA1900 $f_{\text{GSM1800 Tx}}$ , Pin=32dBm	27	37	-	dB
VSWR 5	VSWR5	ANT port, $f_{\text{GSM1800 Tx}}$	-	1.5	2.0	
VSWR 6	VSWR6	GSM1800 Tx port, $f_{\text{GSM1800 Tx}}$	-	1.5	2.0	
2nd Harmonic Suppression 2	2HS(2)	GSM1800 Tx to ANT, 2x $f_{\text{GSM1800 Tx}}$	28	35	-	dB
3rd Harmonic Suppression 2	3HS(2)	GSM1800 Tx to ANT, 3x $f_{\text{GSM1800 Tx}}$	28	35	-	dB
2nd Harmonics 2	2fo(2)	fo= $f_{\text{GSM1800 Tx}}$ , Pin=32dBm	-	-85	-70	dBc
3rd Harmonics 2	3fo(2)	fo= $f_{\text{GSM1800 Tx}}$ , Pin=32dBm	-	-80	-70	dBc

## ■ ELECTRICAL CHARACTERISTICS 5(GSM1800 Rx ON mode)

(General conditions:  $T_a=+25^{\circ}\text{C}$ ,  $Z_s=Z_i=50\Omega$ ,  $VDD=2.7\text{V}$ ,  $VCTL(L)=0\text{V}$ ,  $VCTL(H)=2.7\text{V}$ )

PARAMETER	SYMBOL	CONDITIONS	MIN	TYP	MAX	UNITS
Frequency Range 4	$f_{\text{GSM1800 Rx}}$	GSM1800 Rx Band	1805	-	1880	MHz
Current Consumption 4	IDD4	Pin=10dBm	-	400	700	$\mu\text{A}$
Insertion Loss 4	LOSS4	ANT - GSM1800 Rx , $f_{\text{GSM1800 Rx}}$	-	1.0	1.3	dB
Isolation 10	ISL10	GSM1800 Tx to ANT, $f_{\text{GSM1800 Tx}}$	25	35	-	dB
VSWR 7	VSWR7	ANT port, $f_{\text{GSM1800 Rx}}$	-	1.5	2.0	
VSWR 8	VSWR8	GSM1800 Rx port, $f_{\text{GSM1800 Rx}}$	-	1.5	2.0	

## ■ Electrical Characteristics 6 (CDMA800 ON mode)

(General conditions:  $T_a=+25^{\circ}\text{C}$ ,  $Z_0=Z_i=50\Omega$ ,  $V_{DD}=2.7\text{V}$ ,  $V_{CTL(L)}=0\text{V}$ ,  $V_{CTL(H)}=2.7\text{V}$ )

PARAMETER	SYMBOL	CONDITIONS	MIN	TYP	MAX	UNITS
Frequency Range 5	$f_{\text{CDMA800 Tx}}$	CDMA800 Tx Band	824	-	849	MHz
Frequency Range 6	$f_{\text{CDMA800 Rx}}$	CDMA800 Rx Band	869	-	894	MHz
Current Consumption 5	IDD5	Pin=27dBm	-	400	700	$\mu\text{A}$
Insertion Loss 5	LOSS5	ANT- CDMA800, $f_{\text{CDMA800 Tx}}$ , $f_{\text{CDMA800 Rx}}$ , Pin=27dBm	-	0.6	0.95	dB
Isolation 11	ISL11	CDMA800 to GSM900 Rx $f_{\text{CDMA800 Tx}}$	25	35	-	dB
Isolation 12	ISL12	CDMA800 to GSM1800 Rx $f_{\text{CDMA800 Tx}}$	30	40	-	dB
0.1dB Compression Input Power 1	$P_{-0.1\text{dB}(1)}$	$f_{\text{CDMA800 Tx}}$	30	34	-	dBm
Input 3 <sup>rd</sup> Order Intercept Point 1	IIP3(1)	$f=829\text{MHz}+849\text{MHz}$ , Pin=24dBm+24dBm *1	65	68	-	dBm
VSWR 9	VSWR9	ANT port , $f_{\text{CDMA800 Tx}}$ , $f_{\text{CDMA800 Rx}}$	-	1.5	2.0	
VSWR 10	VSWR10	CDMA800 port, $f_{\text{CDMA800 Tx}}$ , $f_{\text{CDMA800 Rx}}$	-	1.5	2.0	

\*1: The input IP3 is defined as following equation,  $\text{IIP3} = (3 \times \text{Pout} - \text{IM3}) / 2 + \text{LOSS}$ .

## ■ ELECTRICAL CHARACTERISTICS 7 (CDMA1900 ON mode)

(General conditions:  $T_a=+25^{\circ}\text{C}$ ,  $Z_0=Z_i=50\Omega$ ,  $V_{DD}=2.7\text{V}$ ,  $V_{CTL(L)}=0\text{V}$ ,  $V_{CTL(H)}=2.7\text{V}$ )

PARAMETER	SYMBOL	CONDITIONS	MIN	TYP	MAX	UNITS
Frequency Range 7	$f_{\text{CDMA1900 Tx}}$	CDMA1900 Tx Band	1850	-	1910	MHz
Frequency Range 8	$f_{\text{CDMA1900 Rx}}$	CDMA1900 Rx Band	1930	-	1990	MHz
Current Consumption 6	IDD6	Pin=27dBm	-	400	700	$\mu\text{A}$
Insertion Loss 6	LOSS6	ANT- CDMA1900, $f_{\text{CDMA1900 Tx}}$ , $f_{\text{CDMA1900 Rx}}$ , Pin=27dBm	-	0.7	1.0	dB
Isolation 13	ISL13	CDMA1900 to GSM900 Rx , $f_{\text{CDMA1900 Tx}}$	25	35	-	dB
Isolation 14	ISL14	CDMA1900 to GSM1800 Rx , $f_{\text{CDMA1900 Tx}}$	40	50	-	dB
0.1dB Compression Input Power 2	$P_{-0.1\text{dB}(2)}$	$f_{\text{CDMA1900 Tx}}$	30	34	-	dBm
Input 3 <sup>rd</sup> Order Intercept Point 2	IIP3(2)	$f=1870\text{MHz}+1910\text{MHz}$ , Pin=24dBm+24dBm *1	65	68	-	dBm
VSWR 11	VSWR11	ANT port , $f_{\text{CDMA1900 Tx}}$ , $f_{\text{CDMA1900 Rx}}$	-	1.4	2.0	
VSWR 12	VSWR12	CDMA1900 port, $f_{\text{CDMA1900 Tx}}$ , $f_{\text{CDMA1900 Rx}}$	-	1.3	2.0	

\*1: The input IP3 is defined as following equation,  $\text{IIP3} = (3 \times \text{Pout} - \text{IM3}) / 2 + \text{LOSS}$ .

## ■ TERMINAL INFORMATION

No.	SYMBOL	DESCRIPTION
1	CDMA1900	RF transmitting/receiving port. An external capacitor is required to block DC voltage.
2	VDD	Positive voltage supply terminal. The positive voltage (+2.5~+3.6V) has to be supplied. Please connect a bypass capacitor with GND terminal for excellent RF performance.
3	GND	Ground terminal. Please connect this terminal with ground plane as close as possible for excellent RF performance.
4	ANT	RF transmitting/receiving port. An external capacitor is required to block DC voltage.
5	GND	Ground terminal. Please connect this terminal with ground plane as close as possible for excellent RF performance.
6	CTL_A	Control signal input terminal. This terminal is set to High-Level (+2.0V~VDD) or Low-Level (0~0.4V).
7	CTL_B	Control signal input terminal. This terminal is set to High-Level (+2.0V~VDD) or Low-Level (0~0.4V).
8	CTL_C	Control signal input terminal. This terminal is set to High-Level (+2.0V~VDD) or Low-Level (0~0.4V).
9	GSM1800 RX	RF receiving port. An external capacitor is required to block DC voltage.
10	GSM900 RX	RF receiving port. An external capacitor is required to block DC voltage.
11	CDMA800	RF transmitting/receiving port. An external capacitor is required to block DC voltage.
12	N/C	No connected terminal.
13	GND	Ground terminal. Please connect this terminal with ground plane as close as possible for excellent RF performance.
14	GSM1800 TX	RF transmitting port. An external capacitor is required to block DC voltage. This port is connected the LPF for GSM1800 Tx band into LTCC substrate.
15	GND	Ground terminal. Please connect this terminal with ground plane as close as possible for excellent RF performance.
16	GSM900 TX	RF transmitting port. An external capacitor is required to block DC voltage. This port is connected the LPF for GSM900 Tx band into LTCC substrate.

## ■ ELECTRICAL CHARACTERISTICS (GSM900 Tx ON mode)

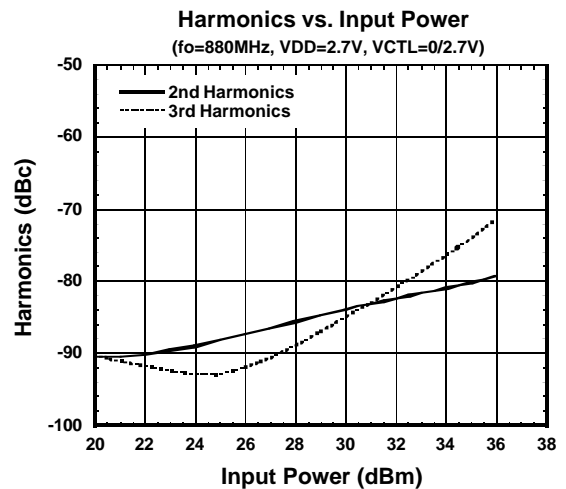
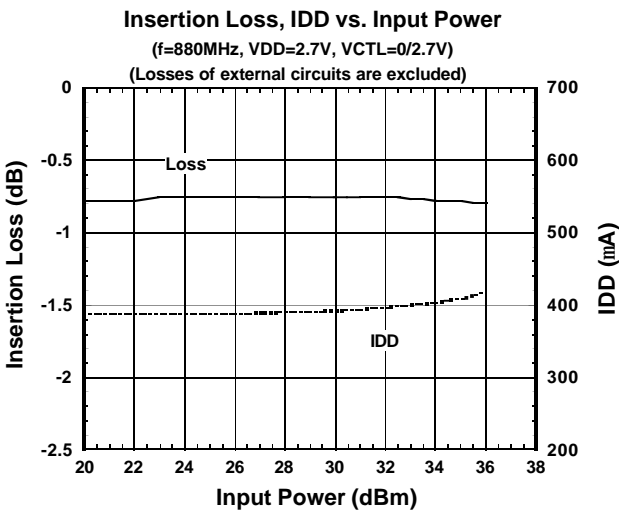
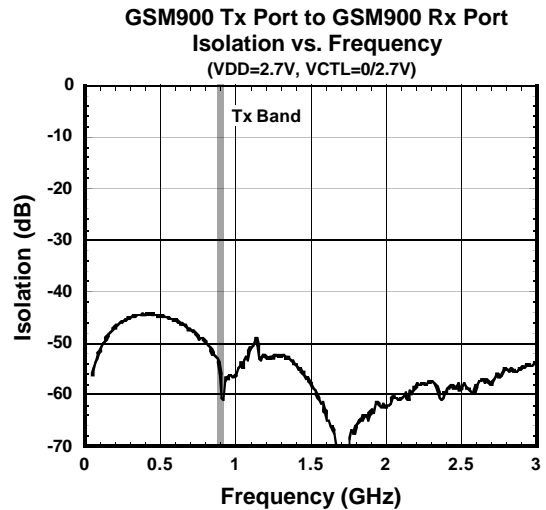
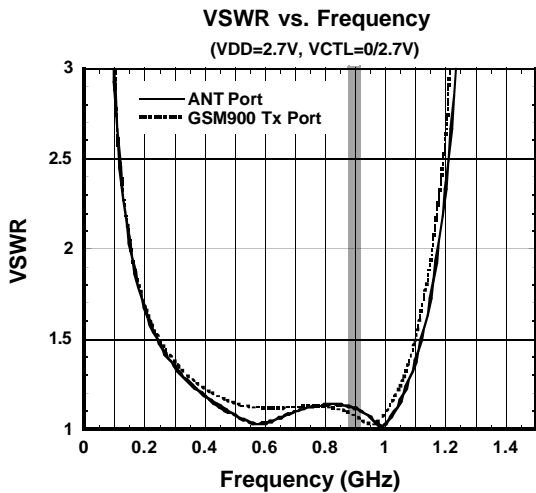
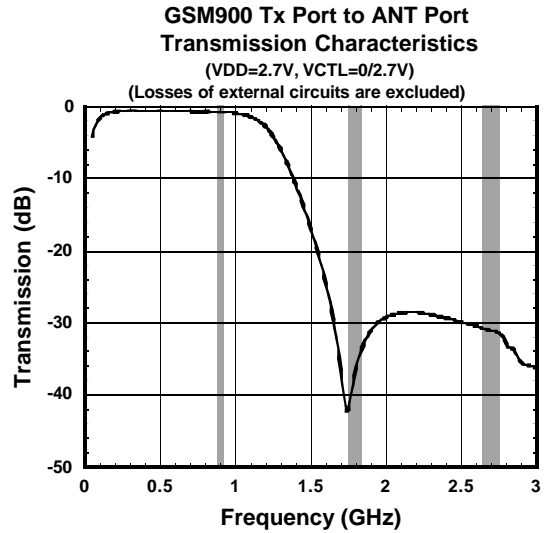
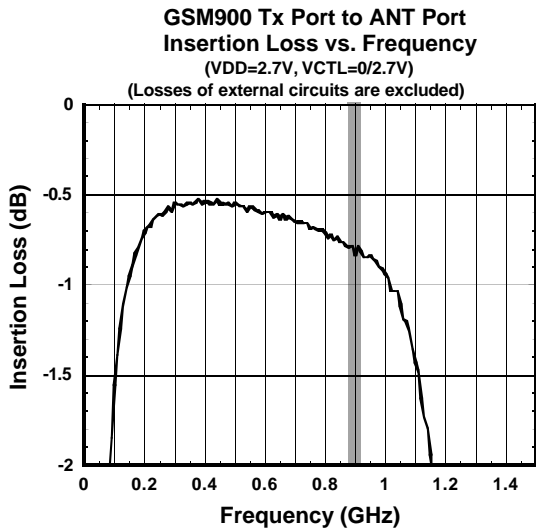



## ELECTRICAL CHARACTERISTICS (GSM900 Tx ON mode)

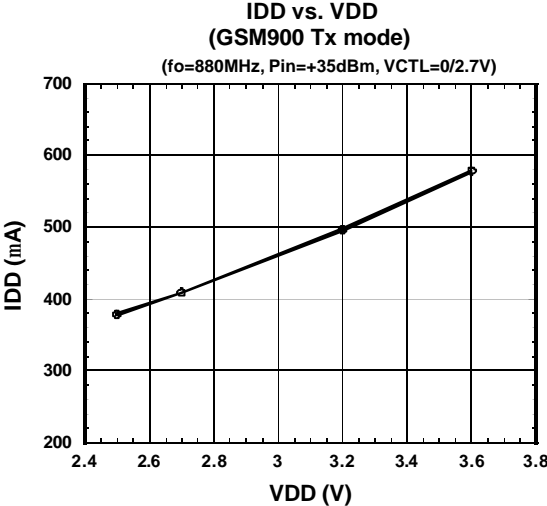
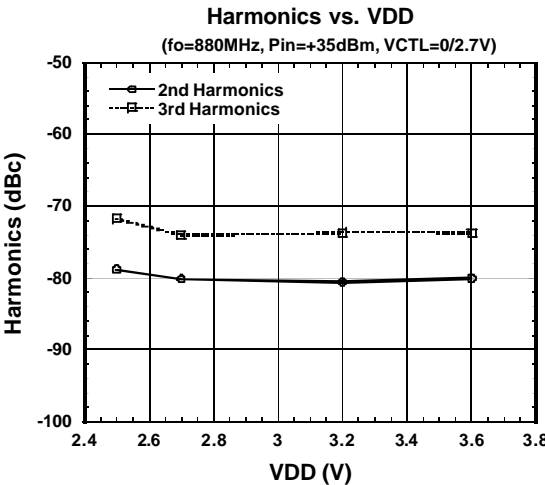
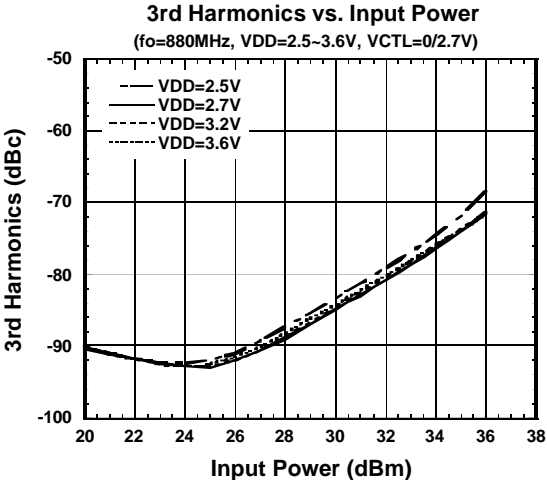
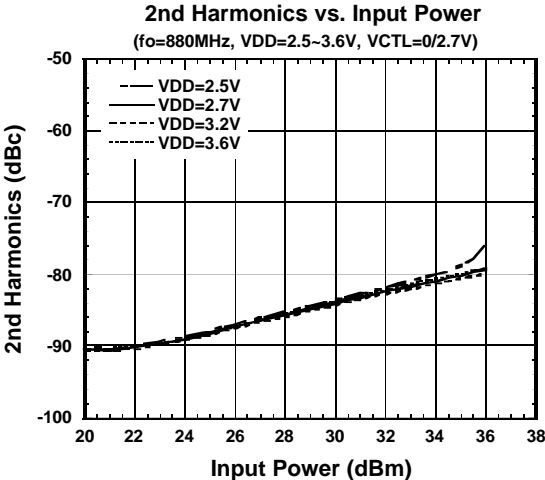

## ELECTRICAL CHARACTERISTICS (GSM900 Tx ON mode)

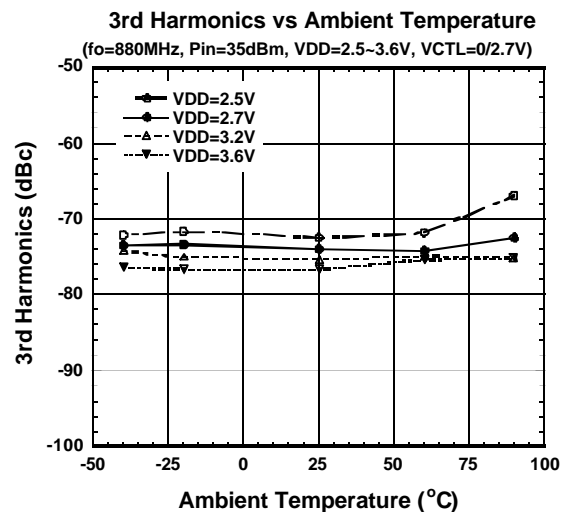
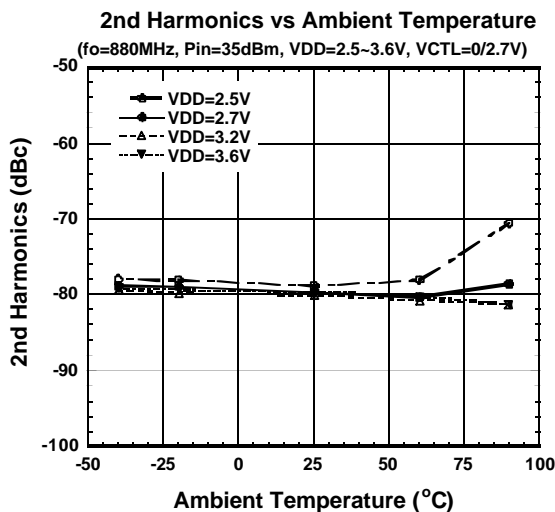
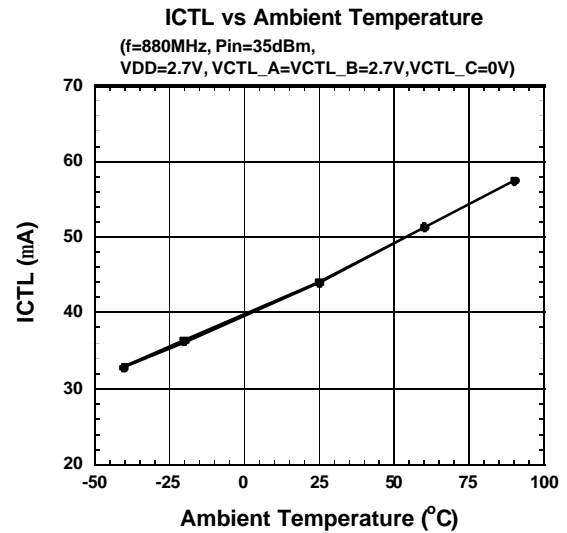
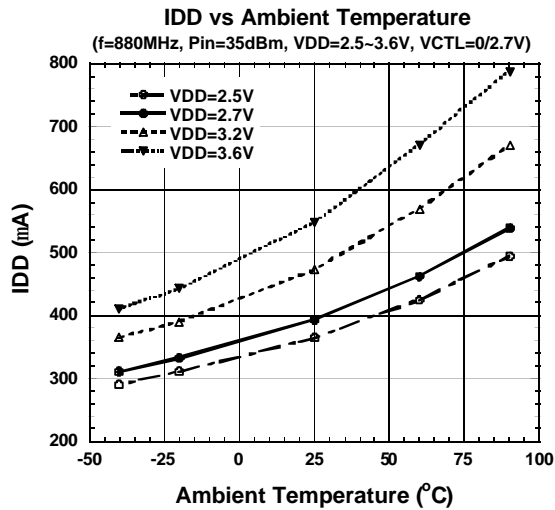
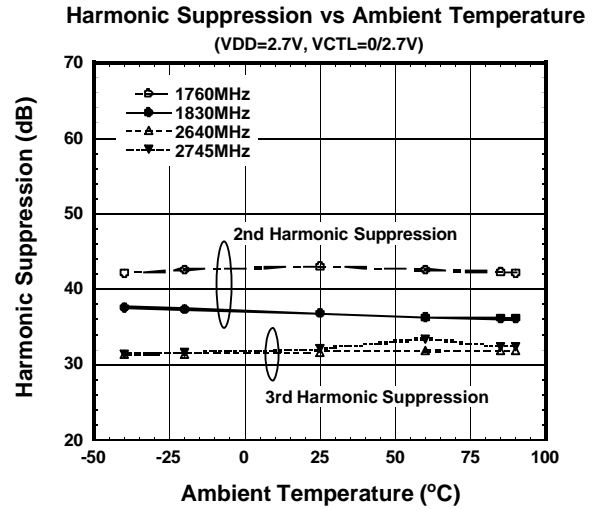
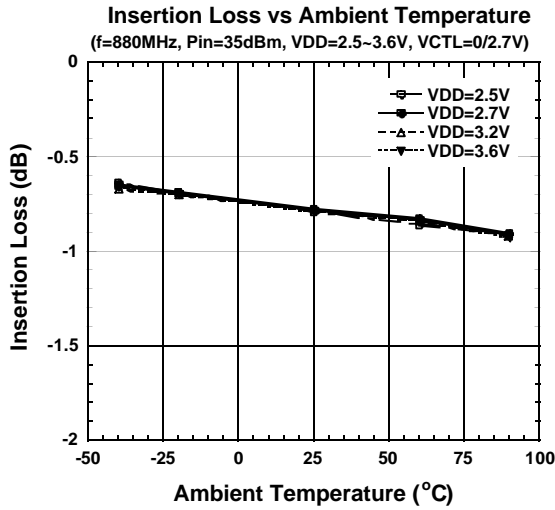

## ELECTRICAL CHARACTERISTICS (GSM900 Rx ON mode)

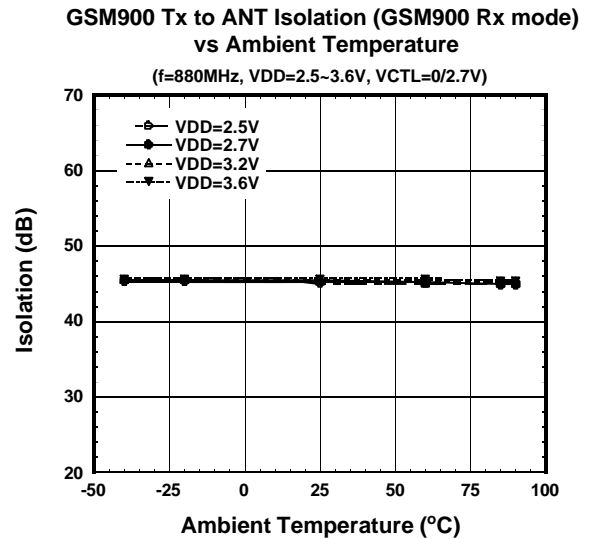
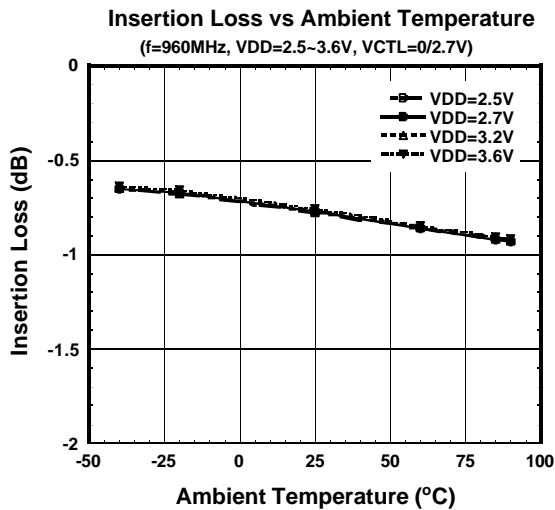
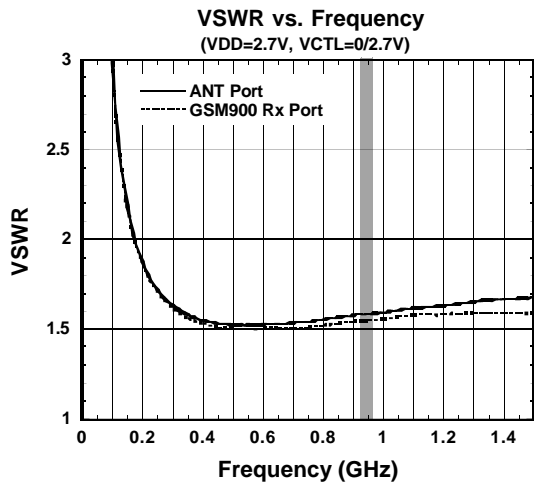
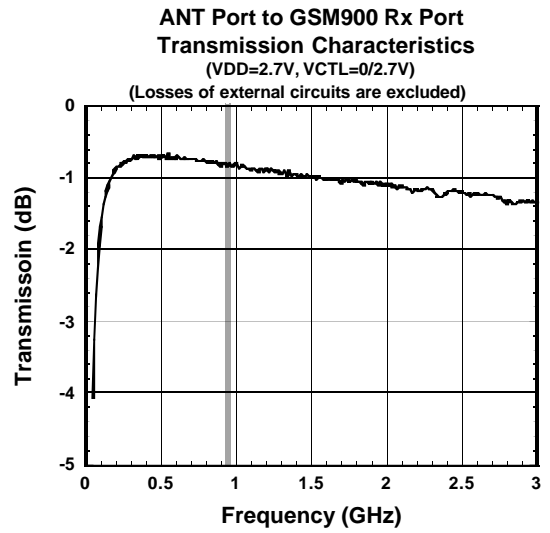
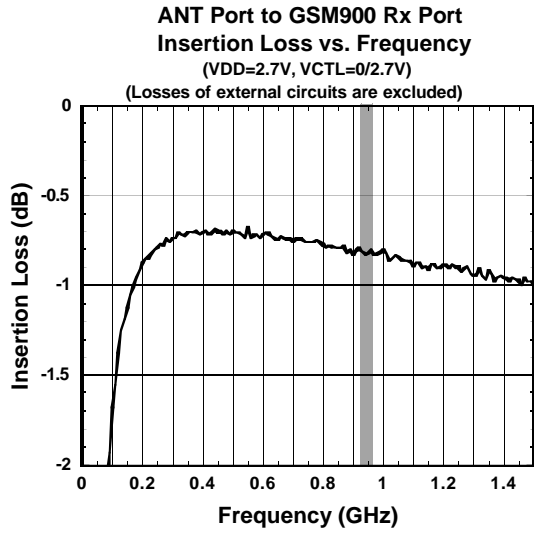

## ■ ELECTRICAL CHARACTERISTICS (GSM1800 Tx ON mode)

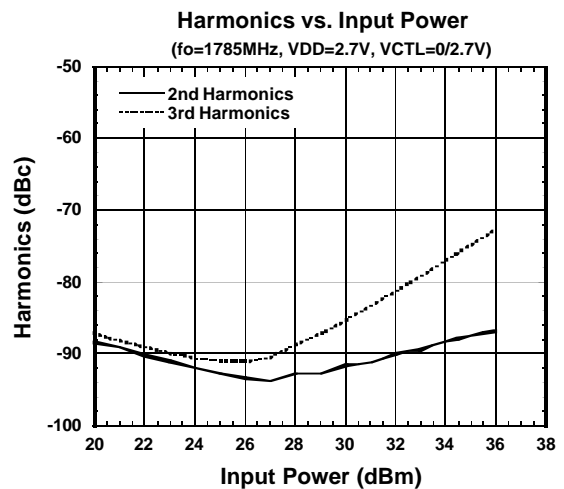
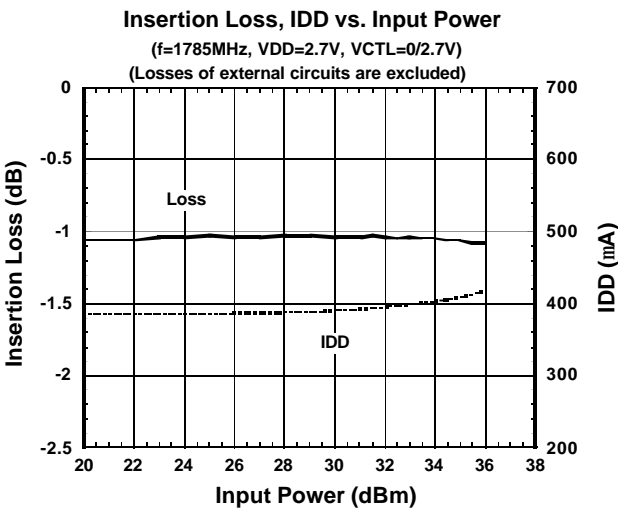
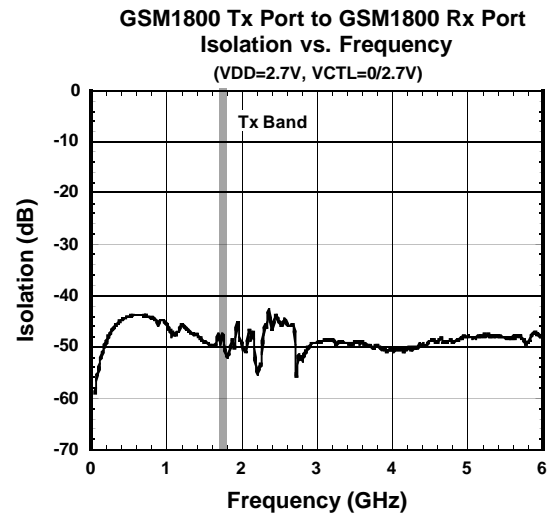
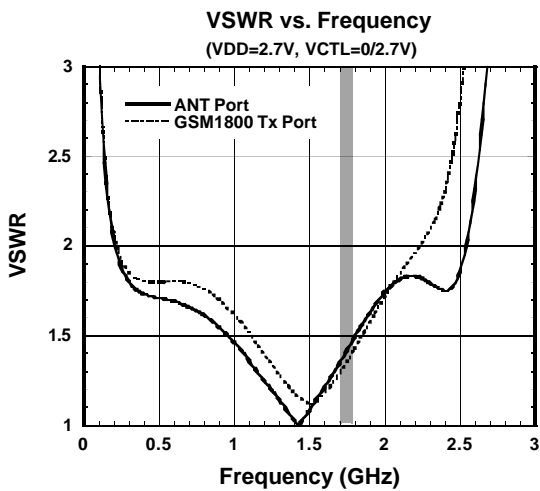
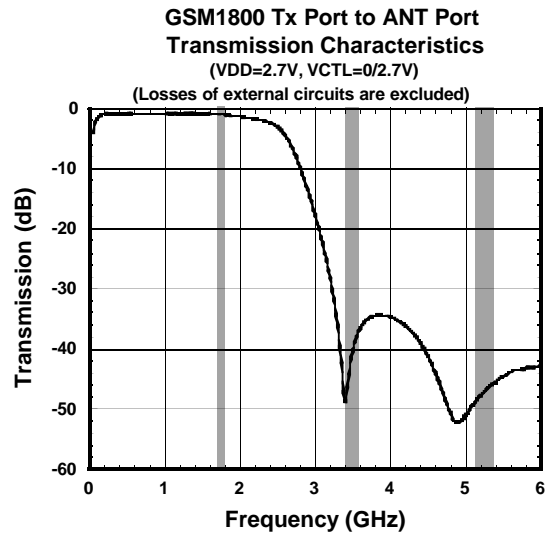
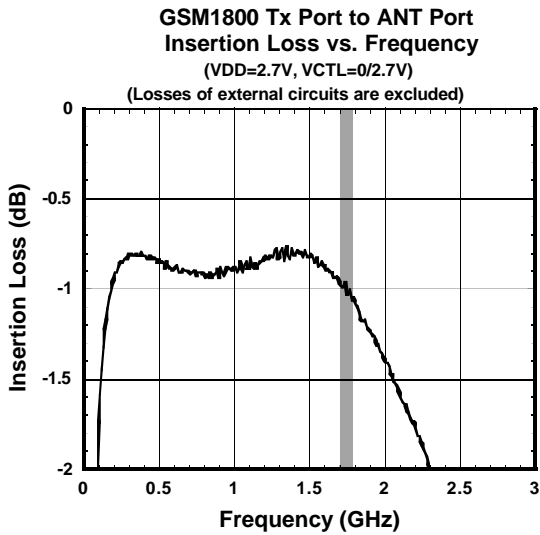

■ ELECTRICAL CHARACTERISTICS (GSM1800 Tx ON mode)

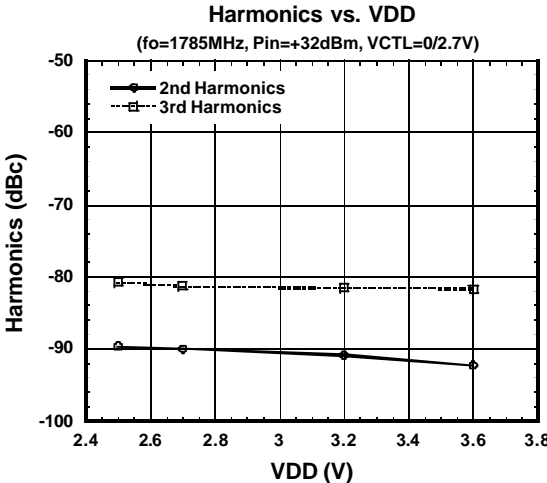
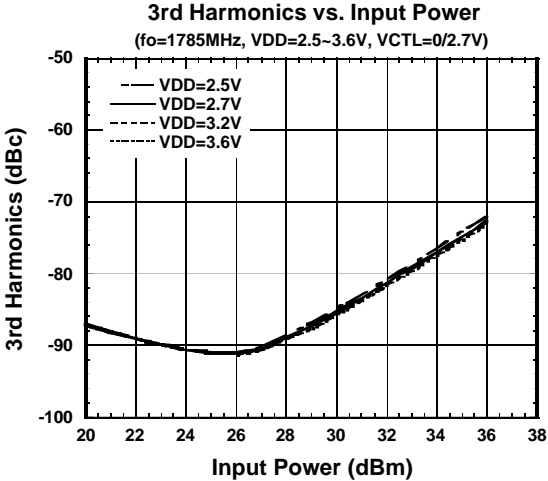
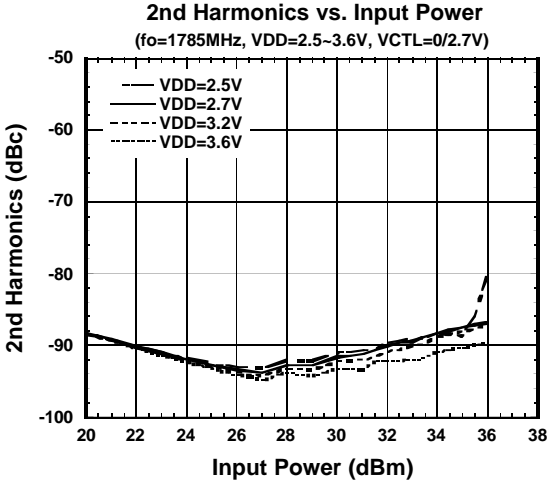

## ELECTRICAL CHARACTERISTICS (GSM1800 Tx ON mode)

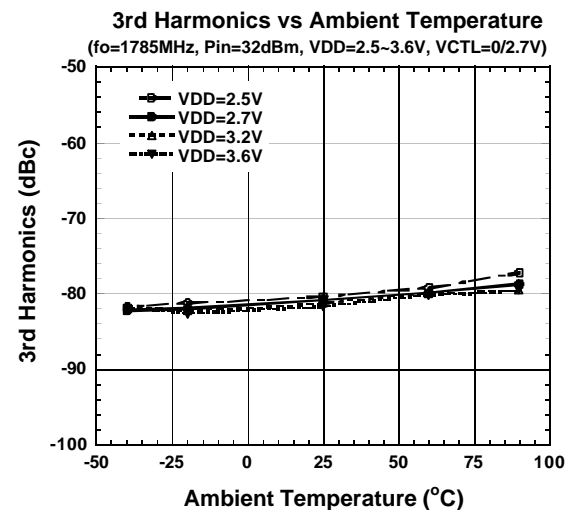
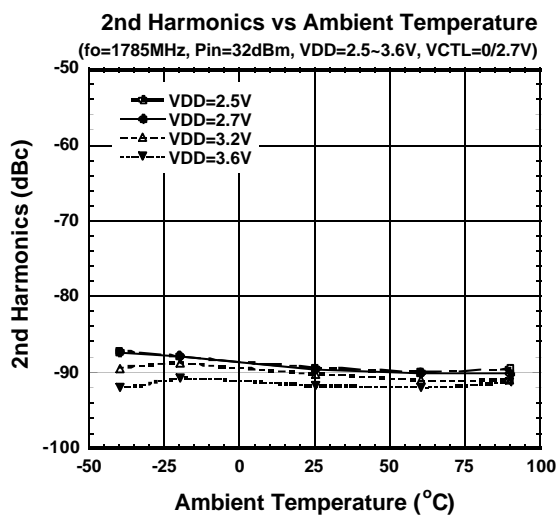
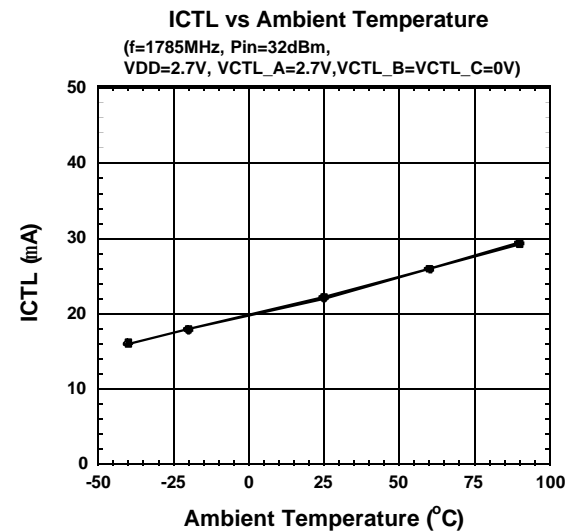
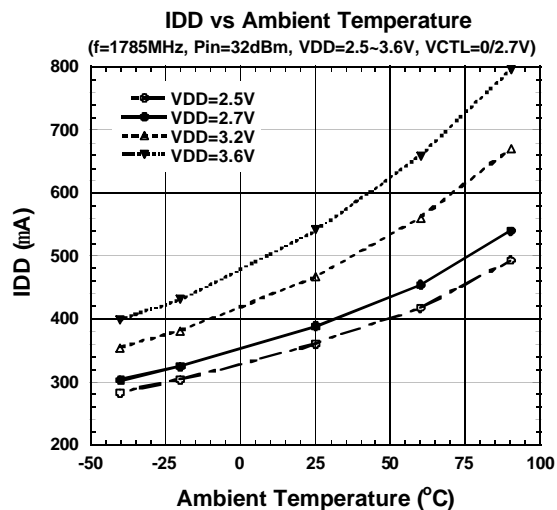
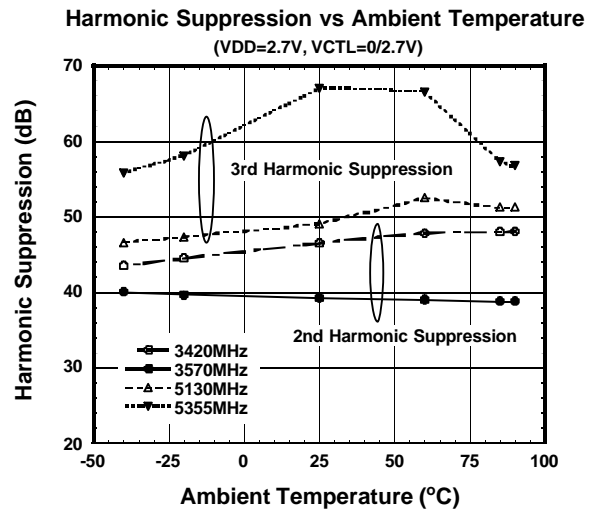
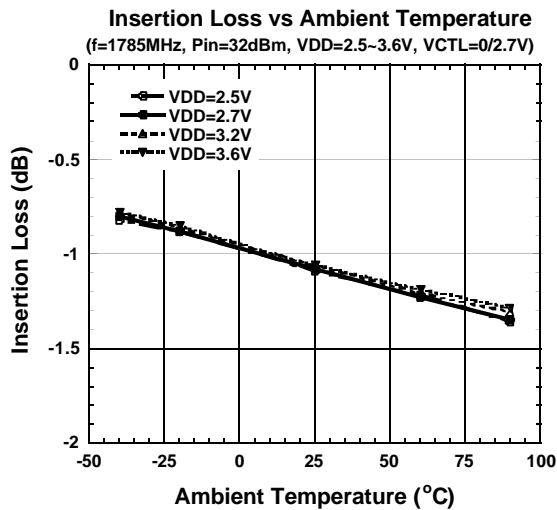

## ELECTRICAL CHARACTERISTICS (GSM1800 Rx ON mode)

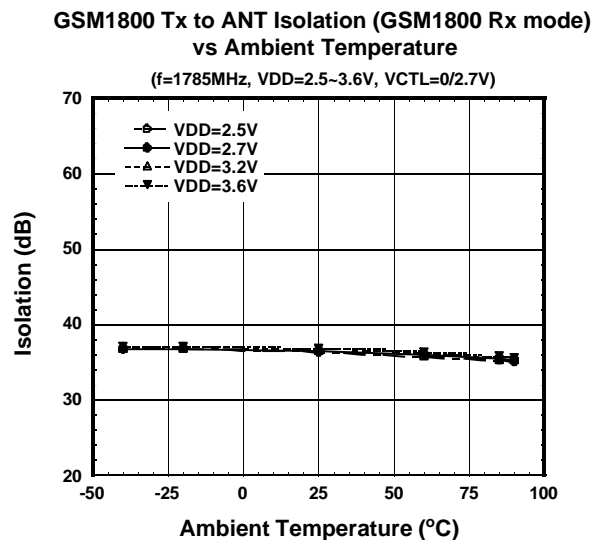
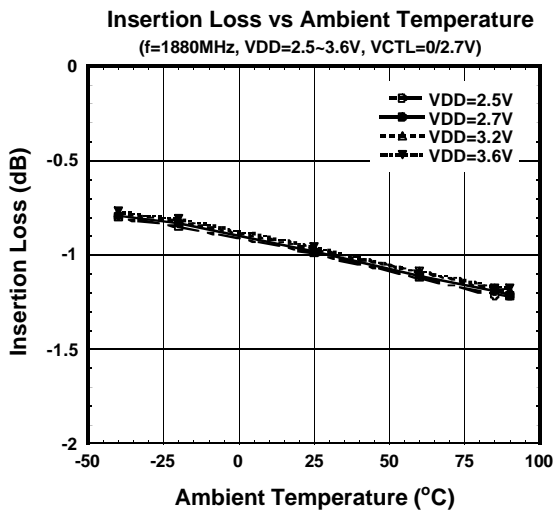
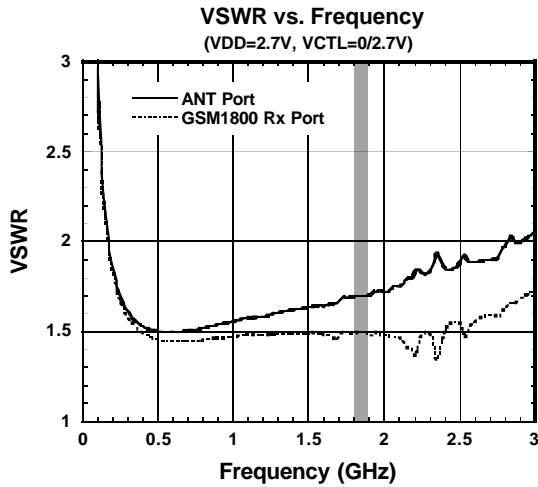
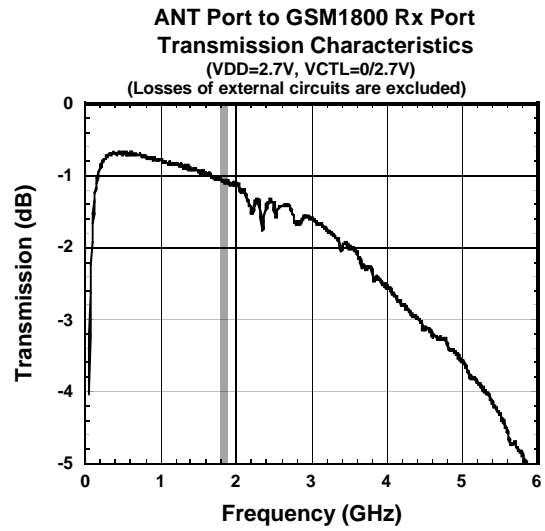
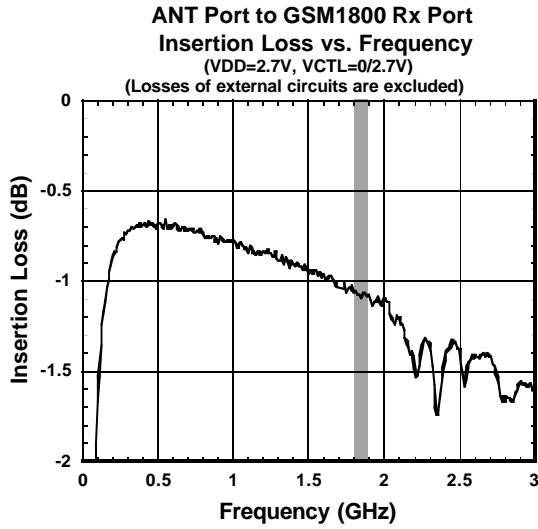

# NJG1634LK5

## ■ ELECTRICAL CHARACTERISTICS (CDMA800 ON mode)

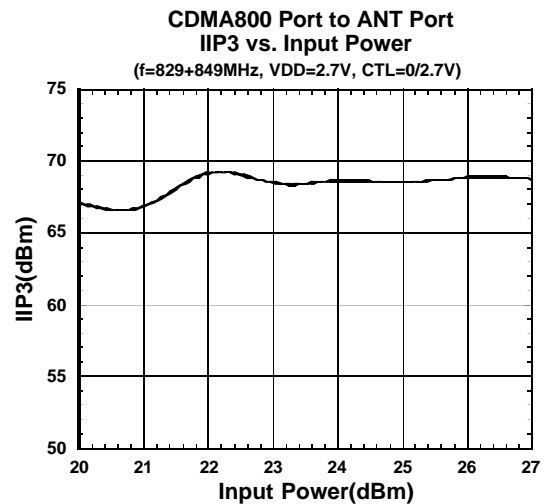
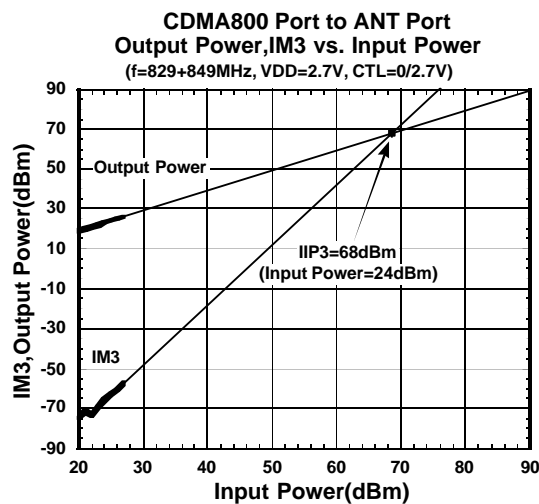
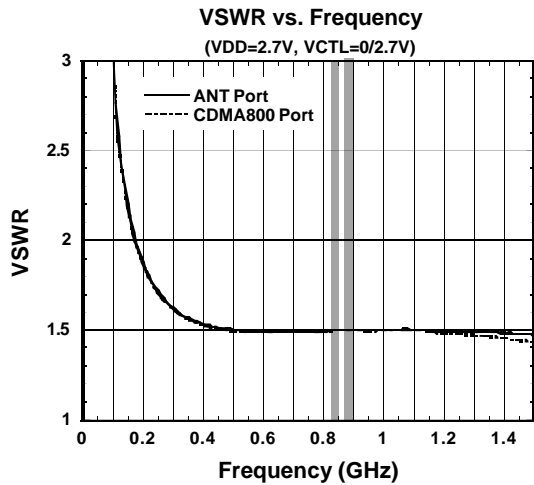
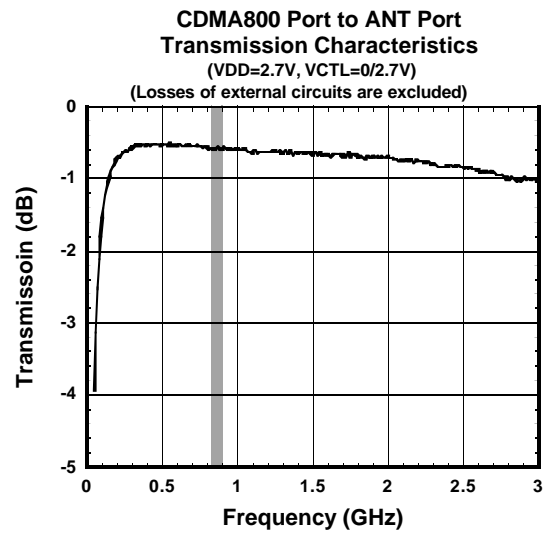
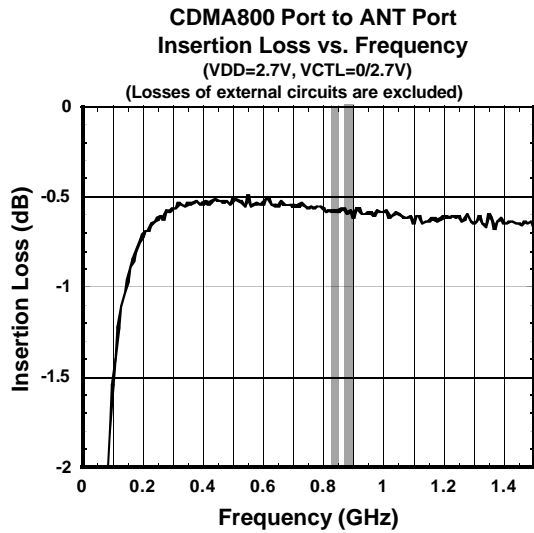



## ELECTRICAL CHARACTERISTICS (CDMA800 ON mode)

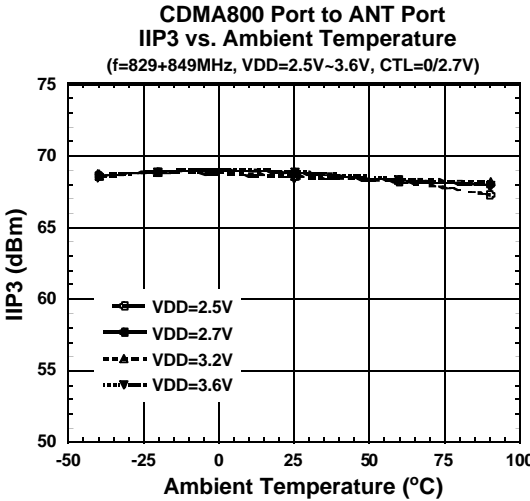
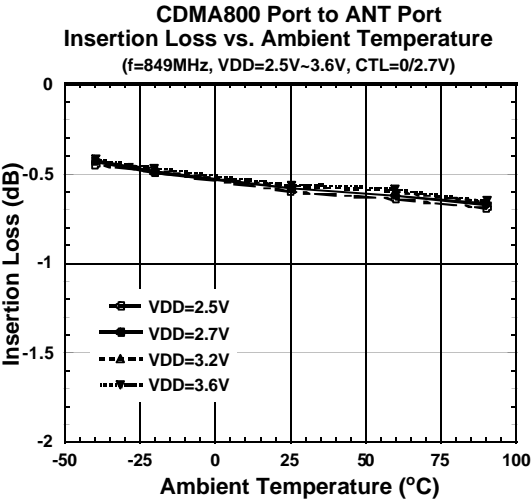
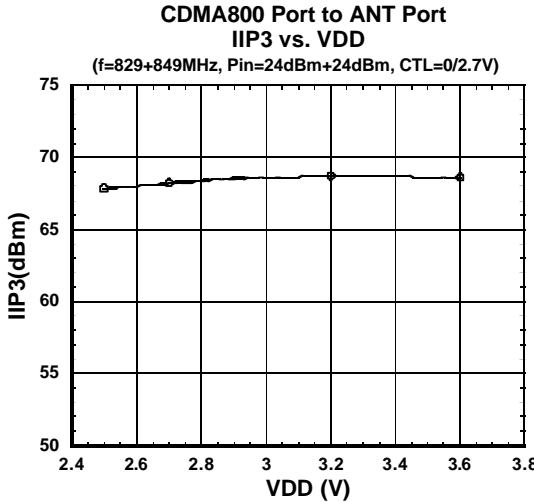
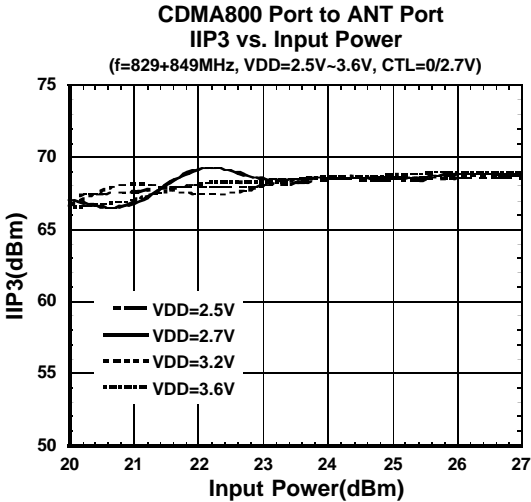

## ■ ELECTRICAL CHARACTERISTICS (CDMA1900 ON mode)

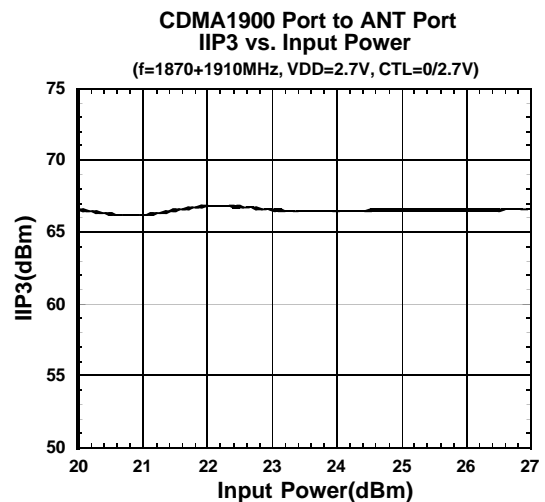
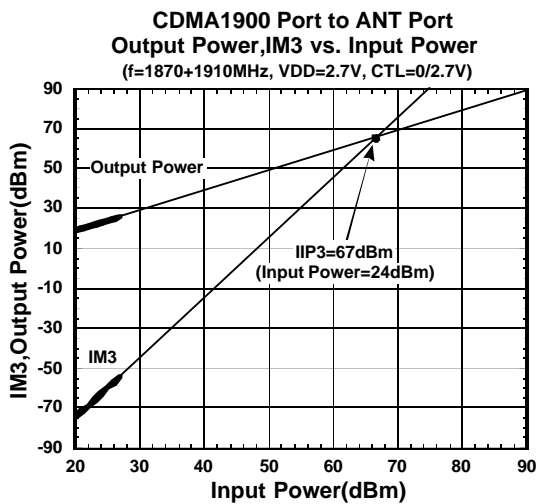
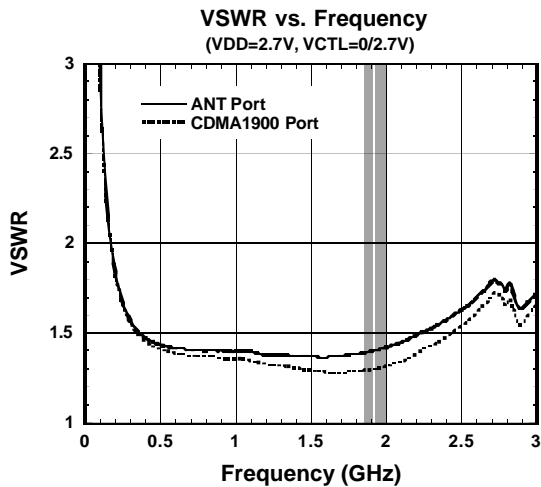
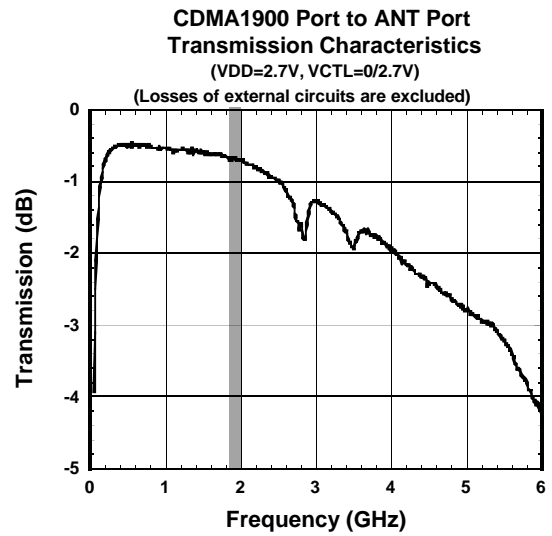
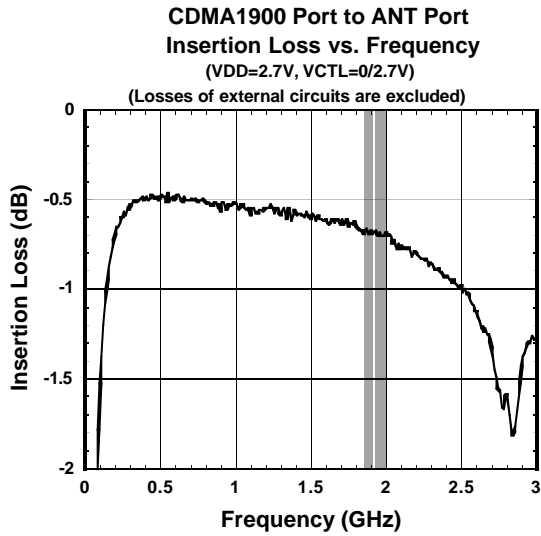

## ELECTRICAL CHARACTERISTICS (CDMA1900 ON mode)

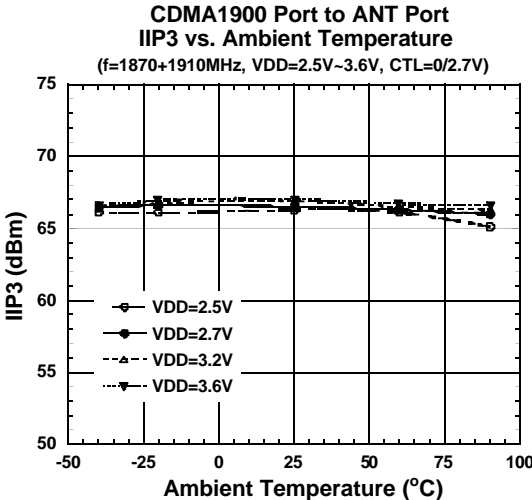
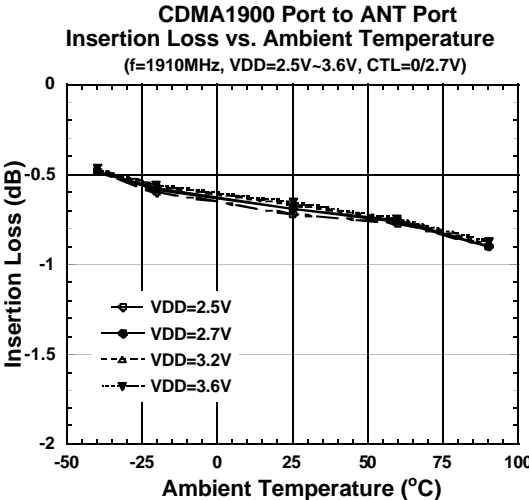
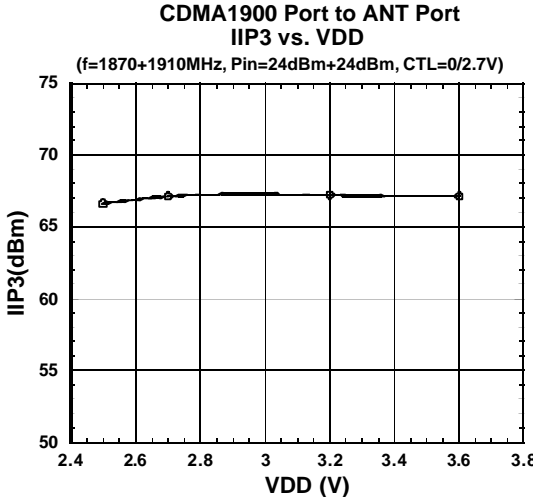
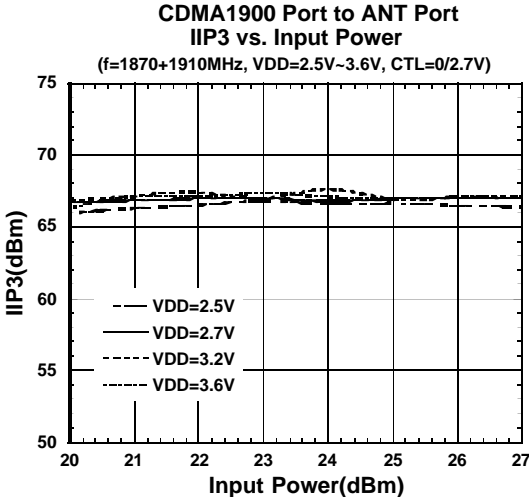

# NJG1634LK5

## APPLICATION CIRCUIT

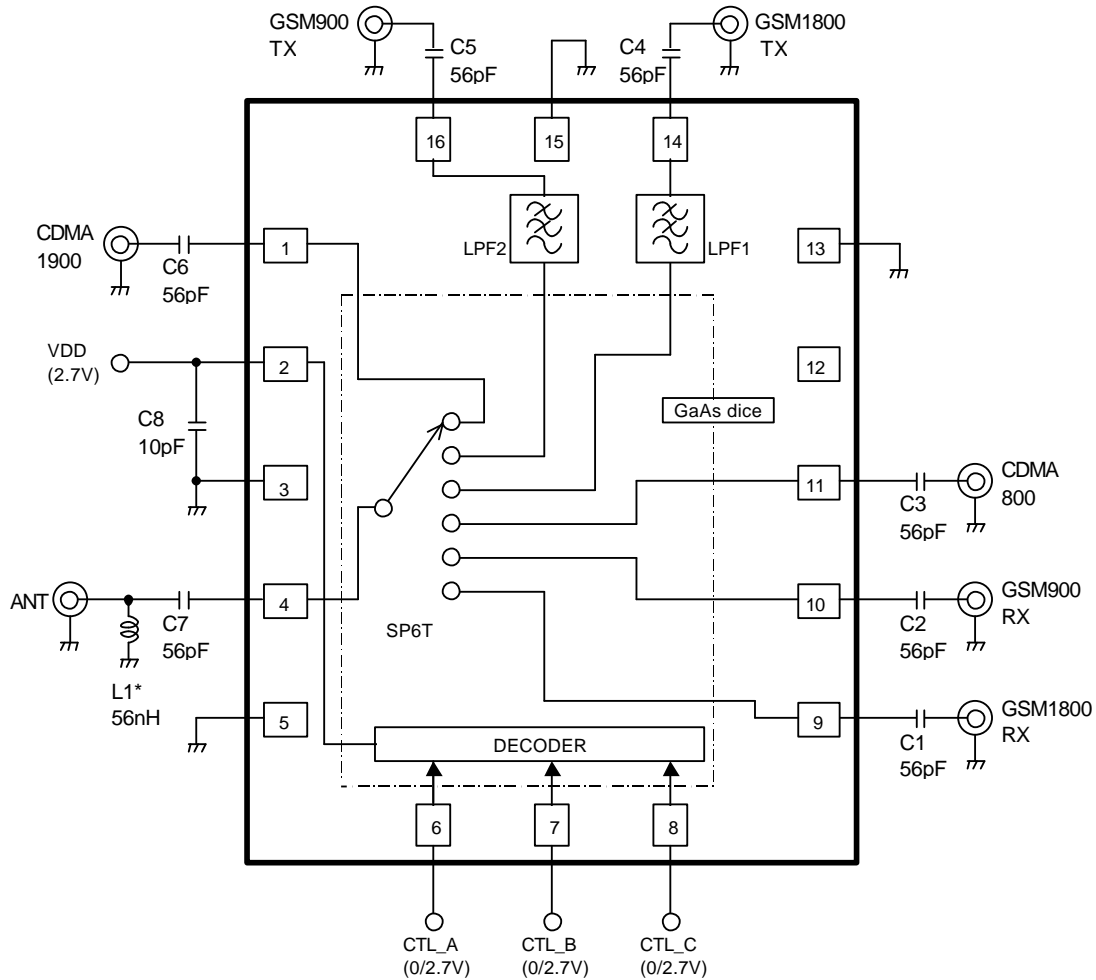

## PARTS LIST

### PARTS LIST

PART ID	Value	COMMENT
C1~C7	56pF	MURATA (GRM15)
C8	10pF	
L1*	56nH	-

\* : Inductor (56nH) is recommended on ANT port for ESD protection

**RECOMMENDED PCB DESIGN**

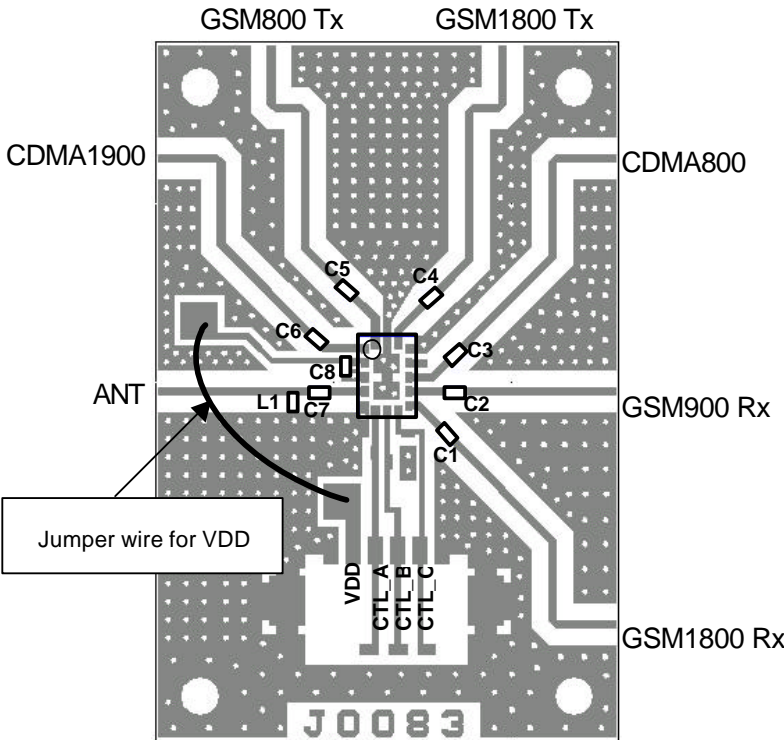

PCB SIZE= 26 x 39 mm  
 PCB: FR-4, t=0.2mm  
 CAPACITOR: size 1005  
 MICROSTRIP LINE WIDTH=0.4mm

Board total losses (Connector and PCB)

Parameter	Mode	Frequency (MHz)	Loss (dB)
Insertion Loss	EGSM Tx	880	0.19
		915	0.22
	EGSM Rx	925	0.16
		960	0.18
	Cellular Tx	824	0.18
		849	0.19
	Cellular Rx	869	0.19
		894	0.20
	DCS Tx	1710	0.36
		1785	0.37
	DCS Rx	1805	0.38
		1880	0.37
PCS Tx	1850	0.36	
	1910	0.38	
PCS RX	1930	0.38	
	1990	0.39	
Harmonics Suppression	EGSM Tx	1760	0.37
		1830	0.37
		2640	0.50
		2745	0.53
	DCS Tx	3420	0.65
		3570	0.69
		5130	0.91
		5355	0.94

**PRECAUTIONS**

- [1] For good RF performance, the ground terminals should be directly connected to the ground patterns and the through-holes as close as possible by using relatively wide pattern.
- [2] Please connect exposed GND PADS (bottom side of IC) to PCB GND using through holes.
- [3] To reduce microstrip line influence on RF characteristics, please locate bypass capacitors (C8) close to VDD terminals.

# NJG1634LK5

## PACKAGE OUTLINE (LCSP16-K5)

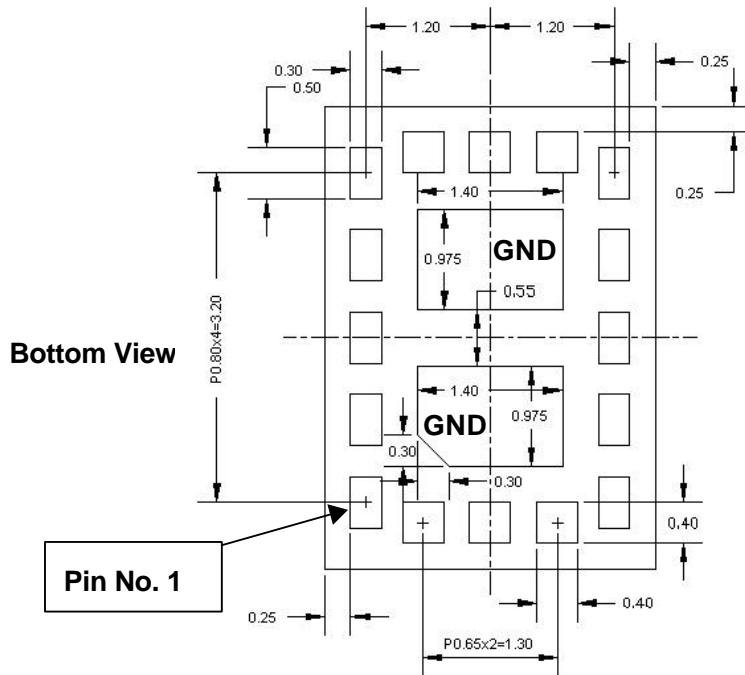
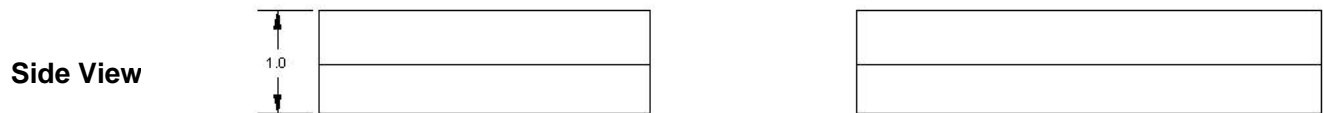
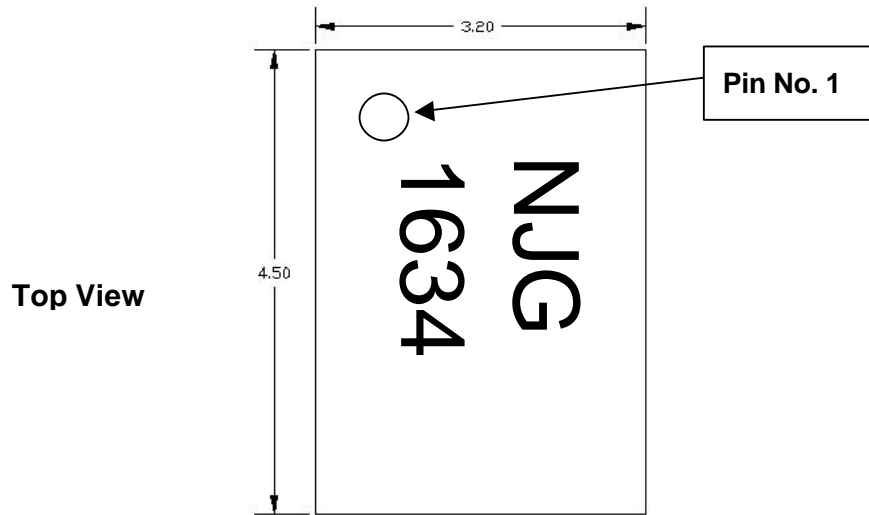

TERMINAL TREAT	Au
SUBSTRATE	LTCC
MOLDING MATERIAL	Epoxy resin
UNIT	mm
WEIGHT	40mg

### Cautions on using this product

- This product contains Gallium-Arsenide (GaAs) which is a harmful material.
- Do NOT eat or put into mouth.
  - Do NOT dispose in fire or break up this product.
  - Do NOT chemically make gas or powder with this product.
  - To waste this product, please obey the relating law of your country.

### [CAUTION]

The specifications on this databook are only given for information, without any guarantee as regards either mistakes or omissions. The application circuits in this databook are described only to show representative usages of the product and not intended for the guarantee or permission of any right including the industrial rights.

This product may be damaged with electric static discharge (ESD) or spike voltage. Please handle with care to avoid these damages.