

X-SP3T SWITCH GaAs MMIC

■ GENERAL DESCRIPTION

The NJG1655ME7 is a GaAs X (cross) - SP3T* switch MMIC, which is designed for switching of balanced signals. The NJG1655ME7 features very low phase error between on-state paths, low insertion loss, low control voltage and wide frequency coverage. The ESD protection circuit are integrated in the IC to achieve high ESD tolerance.

The NJG1655ME7 is available in a very small, lead-free, halogen-free, 2.0mm x 2.0mm x 0.397 mm, 18-pin EQFN18-E7 package.

■ PACKAGE OUTLINE

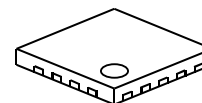

NJG1655ME7

■ FEATURES

- Low voltage operation $V_{DD}=+1.5\sim+4.5V$
- Low voltage logic control $V_{CTL(H)}=+1.3V$ min.
- Low insertion loss
 - 0.40dB typ. @ $f=1.0GHz$
 - 0.45dB typ. @ $f=2.0GHz$
- Operating current consumption 20 μA typ. @ $V_{DD}=2.7V$
- Low phase error ± 3 deg @ $f=2.0GHz$
- Small package EQFN18-E7 (Package size: 2.0mm x 2.0mm x 0.397mm typ.)
- Integrated ESD protection circuit
- Lead-free, RoHs compliant and halogen-free

■ PIN CONFIGURATION

(Top View)

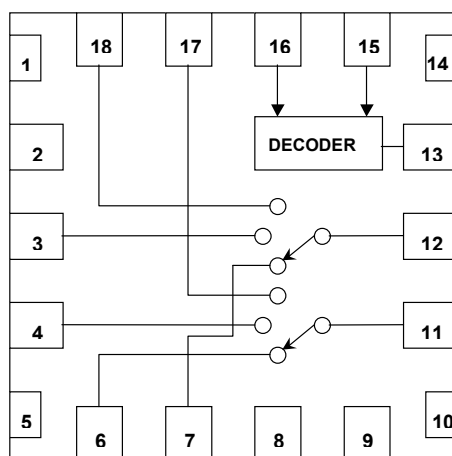

Pin connection

- | | |
|------------|-----------|
| 1. GND | 11. PCB |
| 2. NC(GND) | 12. PCA |
| 3. P2A | 13. VDD |
| 4. P2B | 14. GND |
| 5. GND | 15. VCTL2 |
| 6. P1B | 16. VCTL1 |
| 7. P1A | 17. P3B |
| 8. GND | 18. P3A |
| 9. NC(GND) | |
| 10. GND | |

■ TRUTH TABLE

ON PATH	"H"= $V_{CTL(H)}$, "L"= $V_{CTL(L)}$	
	VCTL1	VCTL2
PCA-P1A PCB-P1B	H	L
PCA-P2A PCB-P2B	L	L
PCA-P3A PCB-P3B	L	H

NOTE: The information on this datasheet is subject to change without notice.

*) X-SP3T is a paired SP3T switch controlled synchronously. The X-SP3T includes two SP3T switches whose RF lines have a crossing inside the chip.

NJG1655ME7

■ ABSOLUTE MAXIMUM RATINGS

($T_a=+25^{\circ}\text{C}$, $Z_s=Z_l=50\Omega$)

PARAMETER	SYMBOL	CONDITIONS	RATINGS	UNITS
RF Input Power	P_{IN}	$V_{DD}=2.7\text{V}$, $V_{CTL}=0\text{V}/1.8\text{V}$	28	dBm
Supply Voltage	V_{DD}	VDD terminal	5.0	V
Control Voltage	V_{CTL}	VCTL1, VCTL2 terminal	5.0	V
Power Dissipation	P_D	Four-layer FR4 PCB with through-hole (74.2mmx74.2mm), $T_j=150^{\circ}\text{C}$	1400	mW
Operating Temp.	T_{opr}		-40~+85	$^{\circ}\text{C}$
Storage Temp.	T_{stg}		-55~+150	$^{\circ}\text{C}$

■ ELECTRICAL CHARACTERISTICS

(General conditions: $T_a=+25^{\circ}\text{C}$, $Z_s=Z_l=50\Omega$, $V_{DD}=2.7\text{V}$, $V_{CTL(L)}=0\text{V}$, $V_{CTL(H)}=1.8\text{V}$, with application circuit)

PARAMETERS	SYMBOL	CONDITIONS	MIN	TYP	MAX	UNITS
Supply Voltage	V_{DD}		1.5	2.7	4.5	V
Operating Current	I_{DD}		-	20	40	μA
Control Voltage (LOW)	$V_{CTL(L)}$		0	-	0.4	V
Control Voltage (HIGH)	$V_{CTL(H)}$		1.3	1.8	4.5	V
Control Current	I_{CTL}		-	5	10	μA
Insertion Loss 1	LOSS1	$f=1.0\text{GHz}$, $P_{IN}=0\text{dBm}$	-	0.40	0.55	dB
Insertion Loss 2	LOSS2	$f=2.0\text{GHz}$, $P_{IN}=0\text{dBm}$	-	0.45	0.70	dB
Isolation 1	ISL1	$f=1.0\text{GHz}$, $P_{IN}=0\text{dBm}$ PCA-P1A,P2A,P3A, PCB-P1B,P2B,P3B	24	27	-	dB
Isolation 2	ISL2	$f=2.0\text{GHz}$, $P_{IN}=0\text{dBm}$ PCA-P1A,P2A,P3A, PCB-P1B,P2B,P3B	18	21	-	dB
Isolation 3	ISL3	$f=2.0\text{GHz}$, $P_{IN}=0\text{dBm}$ PCA-PCB	15	18	-	dB
Phase Error	PE	$f=2\text{GHz}$	-3	-	3	deg
Input Power at 0.2dB Compression Point	$P_{-0.2\text{dB}}$	$f=2\text{GHz}$	18	23	-	dBm
VSWR	VSWR	$f=2\text{GHz}$, on state	-	1.1	1.3	
Switching Time	T_{sw}	50% V_{CTL} to 10%/90% RF	-	2	5	μs

■ TERMINAL INFORMATION

No.	SYMBOL	DESCRIPTION
1, 5, 8 10, 14,	GND	Ground terminal. Connect to the PCB ground plane.
2, 9	NC(GND)	No connected terminal. This terminal is not connected with internal circuit. Connect to the PCB ground plane.
3	P2A	The 2nd RF port of the 1st switch. This port is connected with PCA port. PCB port is connected with P2B port at the same time. An external capacitor is required to block DC voltage.
4	P2B	The 2nd RF port of the 2nd switch. This port is connected with PCB port. PCA port is connected with P2A port at the same time. An external capacitor is required to block DC voltage.
6	P1B	The 1st RF port of the 2nd switch. This port is connected with PCB port. PCA port is connected with P1A port at the same time. An external capacitor is required to block DC voltage.
7	P1A	The 1st RF port of the 1st switch. This port is connected with PCA port. PCB port is connected with P1B port at the same time. An external capacitor is required to block DC voltage.
11	PCB	Common RF port of the 2nd switch. This port is connected with either of P1B, P2B, and P3B port. An external capacitor is required to block DC voltage.
12	PCA	Common RF port of the 1st switch. This port is connected with either of P1A, P2A, and P3A port. An external capacitor is required to block DC voltage.
13	VDD	Positive voltage supply terminal. The positive voltage (+1.5~+4.5V) should be supplied. Please connect a bypass capacitor with GND terminal for best RF performance.
15	VCTL2	Control signal input terminal. This terminal is set to High-Level (+1.3V~4.5V) or Low-Level (0~+0.4V).
16	VCTL1	Control signal input terminal. This terminal is set to High-Level (+1.3V~4.5V) or Low-Level (0~+0.4V).
17	P3B	The 3rd RF port of the 2nd switch. This port is connected with PCB port. PCA port is connected with P3A port at the same time. An external capacitor is required to block DC voltage.
18	P3A	The 3rd RF port of the 1st switch. This port is connected with PCA port. PCB port is connected with P3B port at the same time. An external capacitor is required to block DC voltage.

NJG1655ME7

■ ELECTRICAL CHARACTERISTICS (Losses of external circuit are excluded, with application circuit)

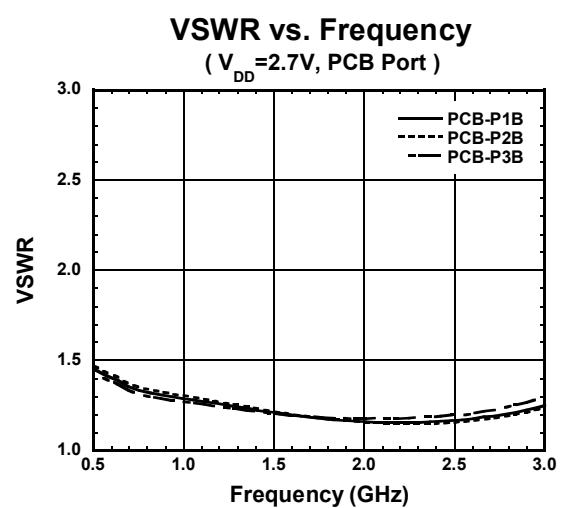
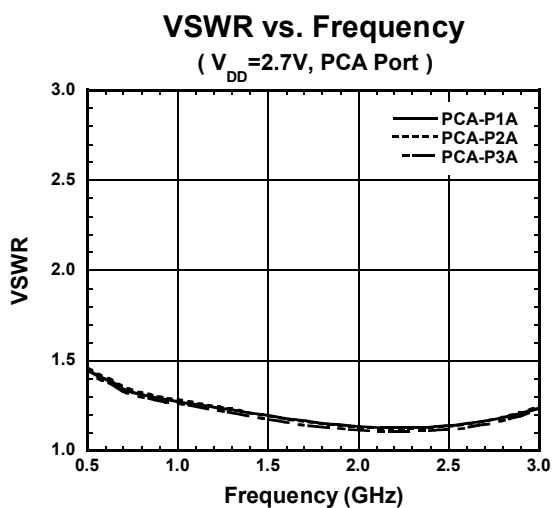
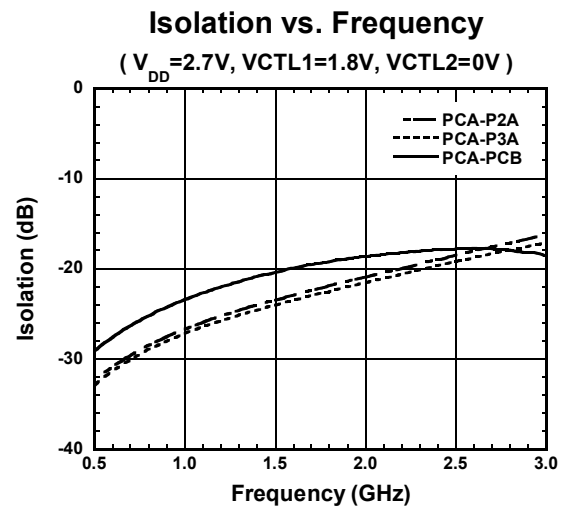
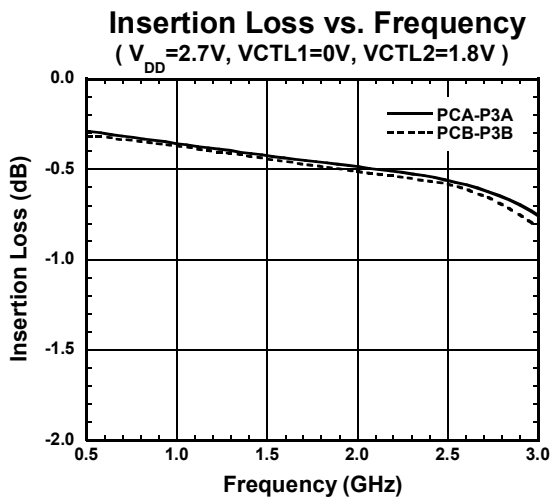
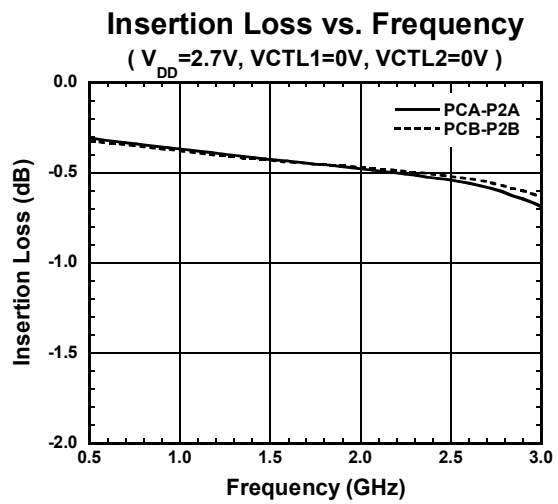
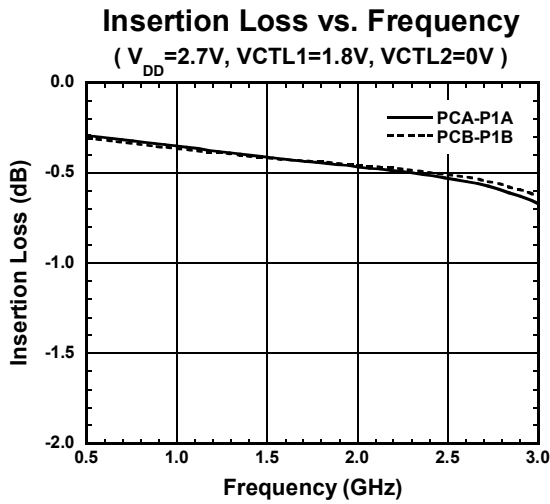

■ ELECTRICAL CHARACTERISTICS (Losses of external circuit are excluded, with application circuit)

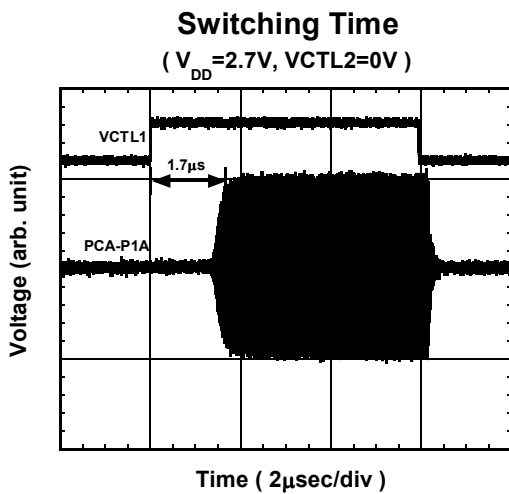
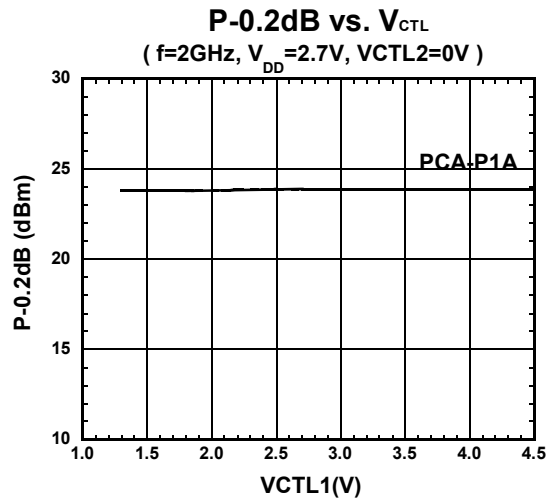
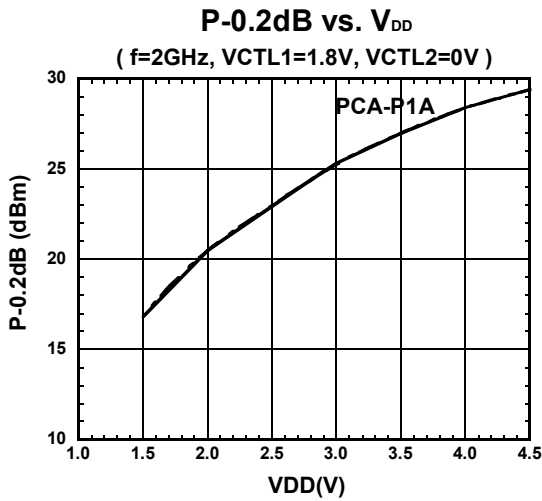
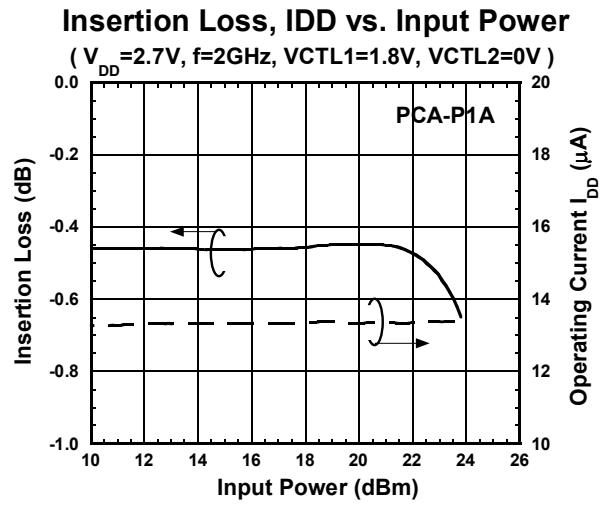
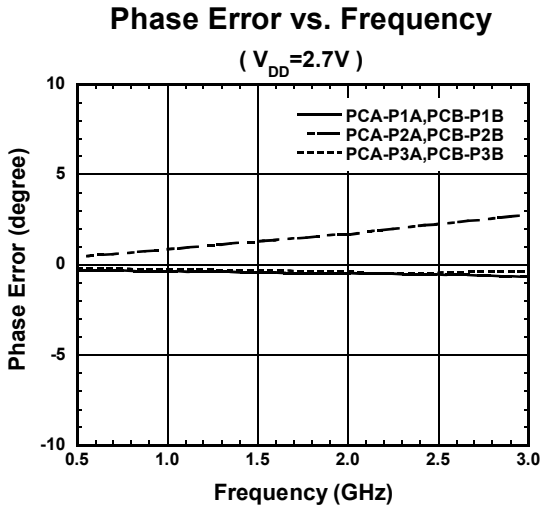

NJG1655ME7

■ELECTRICAL CHARACTERISTICS (Losses of external circuit are excluded, with application circuit)

Insertion Loss vs. Ambient Temperature

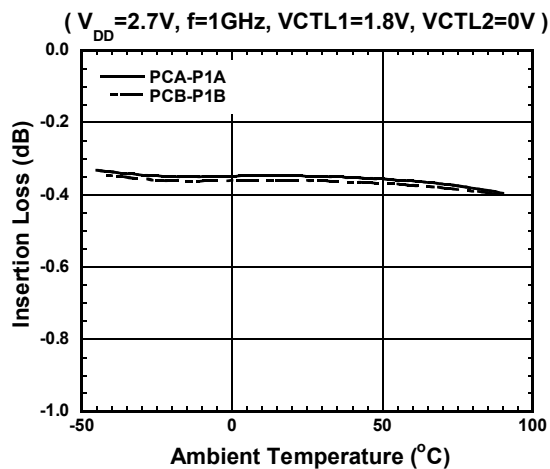

Insertion Loss vs. Ambient Temperature

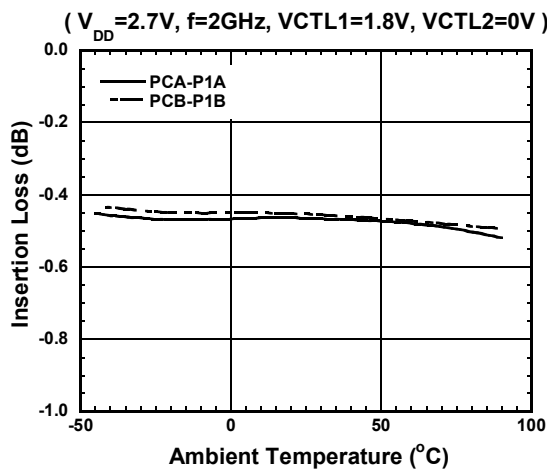

Insertion Loss vs. Frequency

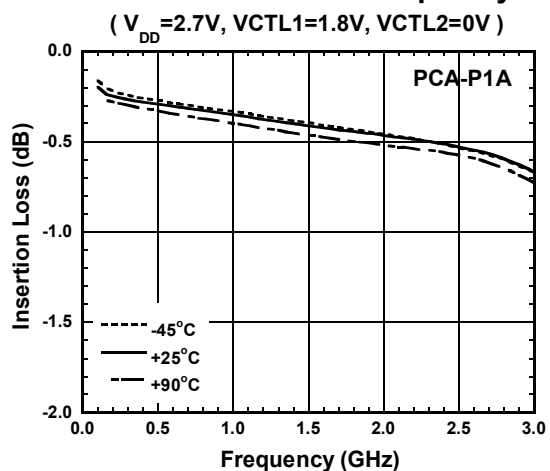

Isolation vs. Ambient Temperature

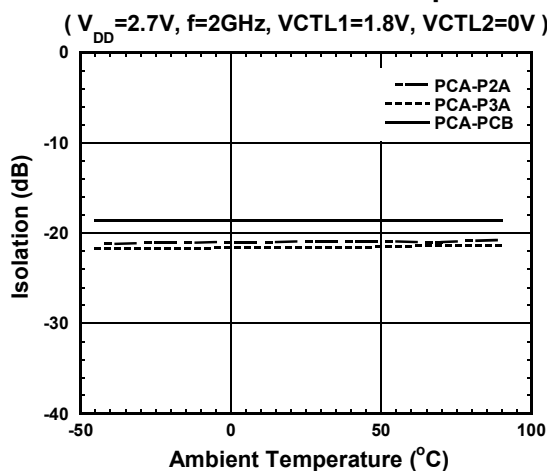

VSWR vs. Ambient Temperature

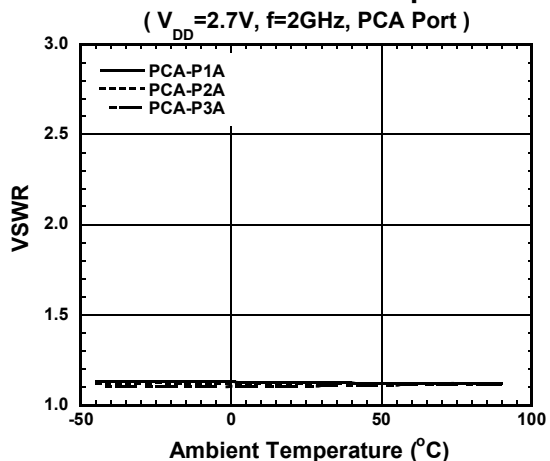

VSWR vs. Ambient Temperature

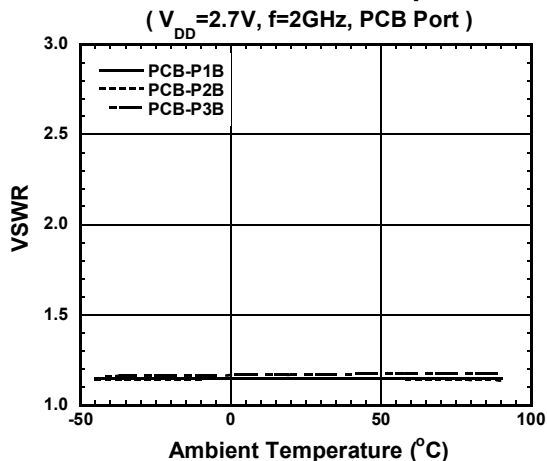

ELECTRICAL CHARACTERISTICS (Losses of external circuit are excluded, with application circuit)

Phase Error vs. Ambient Temperature

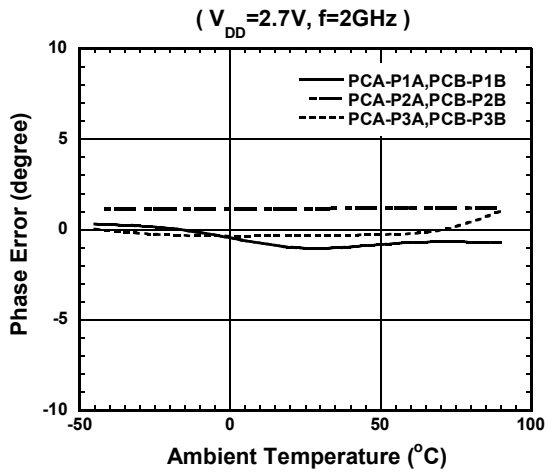

Phase Error vs. Frequency

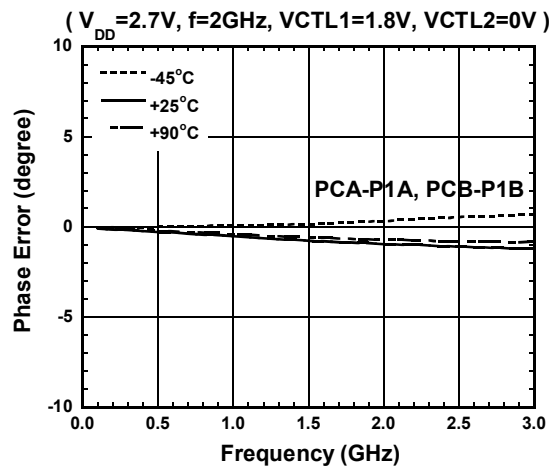

P-0.2dB vs. Ambient Temperature

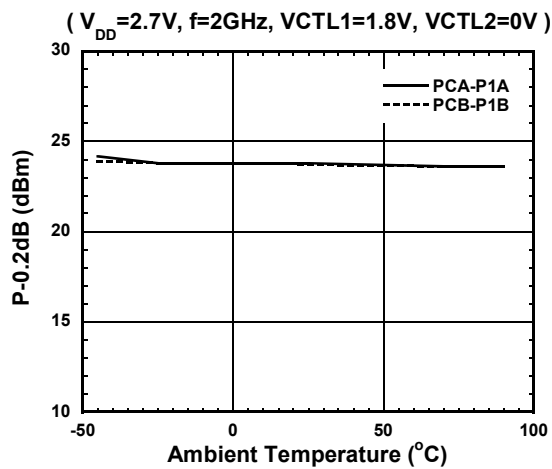

P-0.2dB vs. Ambient Temperature

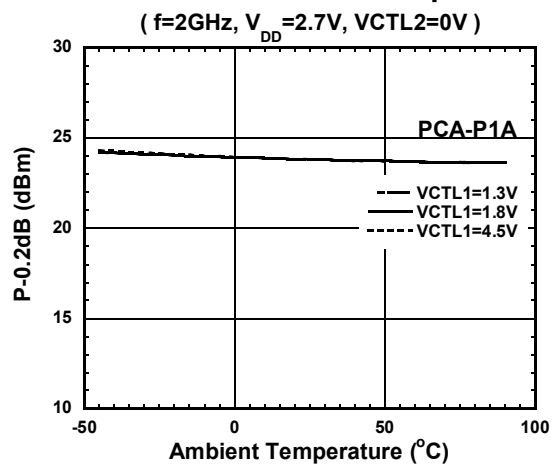

Switching Time vs. Ambient Temperature

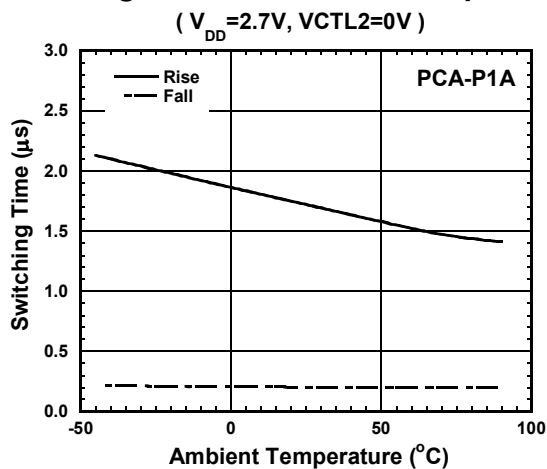

NJG1655ME7

APPLICATION CIRCUIT

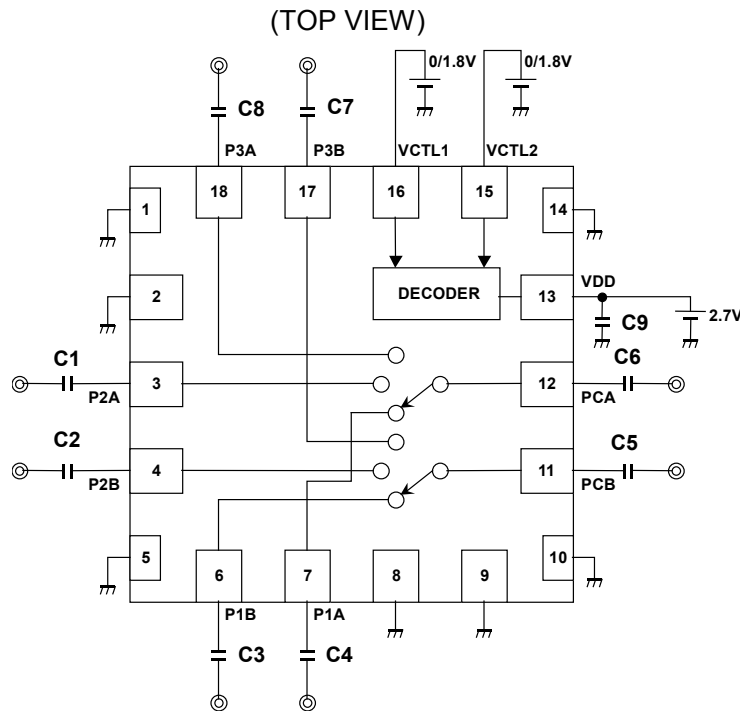

PARTS LIST

PART ID	Value	Notes
C1~C8	56pF	MURATA (GRM15)
C9	1000pF	

TEST PCB LAYOUT

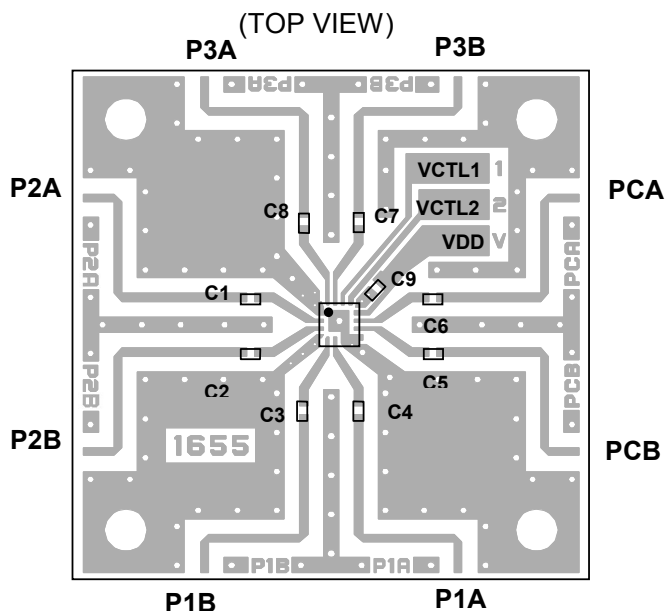

Losses of PCB, capacitors and connectors

Frequency	Loss
1GHz	0.36dB
2GHz	0.49dB

PRECAUTIONS

- [1] The DC blocking capacitors (C1~C8) must be placed at all RF terminals (PCA, PCB, P1A, P1B, P2A, P2B, P3A and P3B).
- [2] The bypass capacitor (C9) should be placed as close as VDD terminal.
- [3] Please layout ground pattern right under this IC to avoid degradation of isolation or high power characteristics.

New Japan Radio Co., Ltd.

PACKAGE OUTLINE (EQFN18-E7)

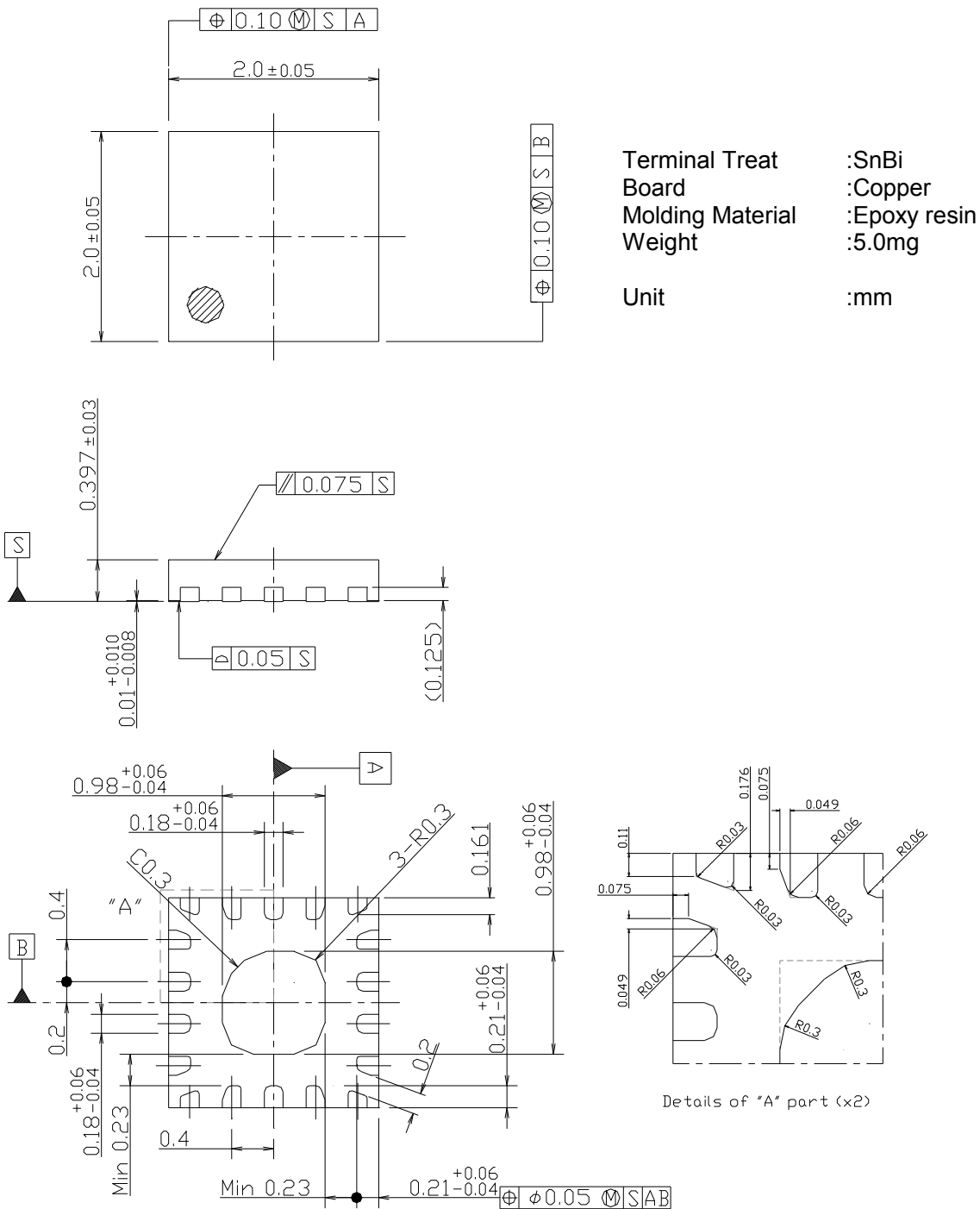

Cautions on using this product

This product contains Gallium-Arsenide (GaAs) which is a harmful material.

- Do NOT eat or put into mouth.
- Do NOT dispose in fire or break up this product.
- Do NOT chemically make gas or powder with this product.
- To waste this product, please obey the relating law of your country.

This product may be damaged with electric static discharge (ESD) or spike voltage. Please handle with care to avoid these damages.

[CAUTION]

The specifications on this databook are only given for information, without any guarantee as regards either mistakes or omissions. The application circuits in this databook are described only to show representative usages of the product and not intended for the guarantee or permission of any right including the industrial rights.