

W-CDMA Triple LNA GaAs MMIC

■GENERAL DESCRIPTION

NJG1125PB5 is a Triple band LNA IC designed for W-CDMA /UMTS cellular phone of 2.1GHz, 1.7GHz and 800MHz band.

This IC has a LNA pass-through function to select high gain mode or low gain mode.

An ultra small and ultra thin package of FFP16-B5 is adopted.

■PACKAGE OUTLINE



NJG1125PB5

■FEATURES

- Low voltage operation +2.85V typ.
- Low ctl voltage operation +1.85V typ.
- Low current consumption 2.4mA typ. @High Gain Mode
0uA typ. @Low Gain Mode
- Package FFP16-B5 (Package size: 2.0 x 2.0 x 0.65mm typ.)

[High gain mode]

- High gain 17.0dB typ. @ $f_{RF}=2140\text{MHz}$
16.5dB typ. @ $f_{RF}=885\text{MHz}$
17.5dB typ. @ $f_{RF}=1860\text{MHz}$
- Low noise figure 1.75dB typ. @ $f_{RF}=2140\text{MHz}$
1.50dB typ. @ $f_{RF}=885\text{MHz}$
1.65dB typ. @ $f_{RF}=1860\text{MHz}$
- High Input IP3 0dBm typ. @ $f_{RF}=2140.0+2140.1\text{MHz}$, Pin=-30dBm
-1dBm typ. @ $f_{RF}=885.0+885.1\text{MHz}$, Pin=-30dBm
+1dBm typ. @ $f_{RF}=1860.0+1860.1\text{MHz}$, Pin=-30dBm

[Low gain mode]

- Gain -8.0dB typ. @ $f_{RF}=2140\text{MHz}$
-6.5dB typ. @ $f_{RF}=885\text{MHz}$
-9.0dB typ. @ $f_{RF}=1860\text{MHz}$
- High Input IP3 +14dBm typ. @ $f_{RF}=2140.0+2140.1\text{MHz}$, Pin=-16dBm
+12dBm typ. @ $f_{RF}=885.0+885.1\text{MHz}$, Pin=-20dBm
+14dBm typ. @ $f_{RF}=1860.0+1860.1\text{MHz}$, Pin=-16dBm

■PIN CONFIGURATION

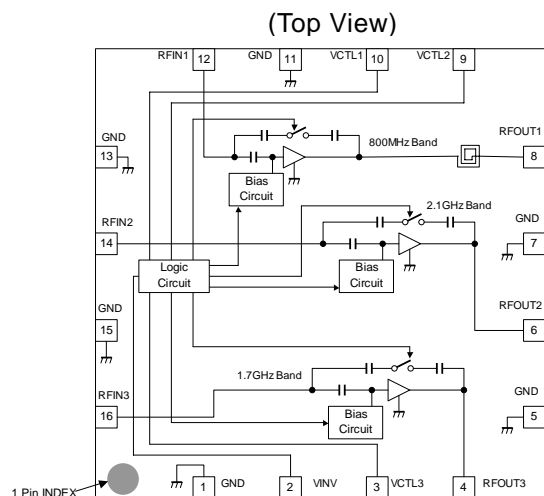

Pin Connection

- | | |
|----------------------|-----------------------|
| 1. GND | 9. VCTL2 (Band Sel.) |
| 2. VINV | 10. VCTL1 (Band Sel.) |
| 3. VCTL3 (Gain Sel.) | 11. GND |
| 4. RFOUT3 (1.7GHz) | 12. RFIN1 (800MHz) |
| 5. GND | 13. GND |
| 6. RFOUT2 (2.1GHz) | 14. RFIN2 (2.1GHz) |
| 7. GND | 15. GND |
| 8. RFOUT1 (800MHz) | 16. RFIN3 (1.7GHz) |

Note: Specifications and description listed in this catalog are subject to change without prior notice.

NJG1125PB5

■ABSOLUTE MAXIMUM RATINGS

T_a=+25°C

PARAMETER	SYMBOL	CONDITIONS	RATINGS	UNITS
Operating voltage	V _{DD}		5.0	V
Inverter supply voltage	V _{INV}		5.0	V
Control voltage	V _{CTL}	V _{CTL} 1, 2, 3	5.0	V
Input power	P _{in}	V _{DD} =2.7V	+15	dBm
Power dissipation	P _D	At on PCB Board	300	mW
Operating temperature	T _{opr}		-40~+85	°C
Storage temperature	T _{stg}		-55~+125	°C

■ELECTRICAL CHARACTERISTICS 1 (DC)

GENERAL CONDITIONS: V_{DD}=V_{INV}=2.85V, T_a=+25°C

PARAMETERS	SYMBOL	CONDITIONS	MIN	TYP	MAX	UNITS
Operating voltage	V _{DD}		2.7	2.85	3.6	V
Inverter supply voltage	V _{INV}		2.7	2.85	3.6	V
Control voltage1 (High)	V _{CTL1(H)}		1.52	1.85	V _{INV} +0.3	V
Control voltage1 (Low)	V _{CTL1(L)}		0	0	0.3	V
Control voltage 2 (High)	V _{CTL2(H)}		1.52	1.85	V _{INV} +0.3	V
Control voltage 2 (Low)	V _{CTL2(L)}		0	0	0.3	V
Control voltage 3 (High)	V _{CTL3(H)}		1.52	1.85	V _{INV} +0.3	V
Control voltage 3 (Low)	V _{CTL3(L)}		0	0	0.3	V
Operating current1 2.1GHz High gain mode	I _{DD1}	V _{CTL1} =0V, V _{CTL2} =0V, V _{CTL3} =1.85V, RF OFF	-	2.4	3.1	mA
Operating current2 800MHz High gain mode	I _{DD2}	V _{CTL1} =1.85V, V _{CTL2} =0V, V _{CTL3} =1.85V, RF OFF	-	2.4	3.1	mA
Operating current3 1.7GHz High gain mode	I _{DD3}	V _{CTL1} =0V, V _{CTL2} =1.85V, V _{CTL3} =1.85V, RF OFF	-	2.4	3.1	mA
Operating current4 Low gain mode	I _{DD4}	V _{CTL3} =0V, RF OFF	-	0	5	uA
Inverter current1	I _{INV1}	V _{CTL3} =1.85V	-	80	130	uA
Inverter current2	I _{INV2}	V _{CTL3} =0V	-	45	80	uA
Control current1	I _{CTL1}	V _{CTL1} =1.85V	-	3	10	uA
Control current2	I _{CTL2}	V _{CTL2} =1.85V	-	3	10	uA
Control current3	I _{CTL3}	V _{CTL3} =1.85V	-	3	10	uA

■ ELECTRICAL CHARACTERISTICS 2 (2.1GHz Band High Gain Mode)

GENERAL CONDITIONS: $V_{DD}=V_{INV}=2.7V$, $V_{CTL1}=0V$, $V_{CTL2}=0V$, $V_{CTL3}=1.85V$, $f_{RF}=2140MHz$,
 $T_a=+25^{\circ}C$, $Z_s=Z_l=50ohm$

PARAMETERS	SYMBOL	CONDITIONS	MIN	TYP	MAX	UNITS
Small signal gain1	Gain1	Exclude PCB & connector losses (IN: 0.09dB, OUT: 0.36dB)	15.0	17.0	19.3	dB
Noise figure1	NF1	Exclude PCB & connector losses (IN: 0.09dB)	-	1.75	2.00	dB
Pin at 1dB gain compression point1	P-1dB(IN)1		-16.0	-12.5	-	dBm
Input 3rd order intercept point1	IIP3_1	$f1=f_{RF}$, $f2=f_{RF}+100kHz$, Pin=-30dBm	-6.0	0.0	-	dBm
RF Input VSWR1	VSWRi1		-	1.7	2.2	
RF Output VSWR1	VSWRo1		-	1.8	2.3	

■ ELECTRICAL CHARACTERISTICS 3 (2.1GHz Band Low Gain Mode)

GENERAL CONDITIONS: $V_{DD}=V_{INV}=2.7V$, $V_{CTL1}=0V$, $V_{CTL2}=0V$, $V_{CTL3}=0V$, $f_{RF}=2140MHz$,
 $T_a=+25^{\circ}C$, $Z_s=Z_l=50ohm$

PARAMETERS	SYMBOL	CONDITIONS	MIN	TYP	MAX	UNITS
Small signal gain2	Gain2	Exclude PCB & connector losses (IN: 0.09dB, OUT: 0.36dB)	-11.0	-8.0	-6.0	dB
Noise figure2	NF2	Exclude PCB & connector losses (IN: 0.09dB)	-	8.5	11.5	dB
Pin at 1dB gain compression point2	P-1dB(IN)2		+5.0	+12.0	-	dBm
Input 3rd order intercept point2	IIP3_2	$f1=f_{RF}$, $f2=f_{RF}+100kHz$, Pin=-16dBm	0.0	+14.0	-	dBm
RF Input VSWR2	VSWRi2		-	2.0	2.4	
RF Output VSWR2	VSWRo2		-	1.5	2.0	

NJG1125PB5

■ELECTRICAL CHARACTERISTICS 4 (800MHz Band High Gain Mode)

GENERAL CONDITIONS: $V_{DD}=V_{INV}=2.7V$, $V_{CTL1}=1.85V$, $V_{CTL2}=0V$, $V_{CTL3}=1.85V$, $f_{RF}=885MHz$,
 $T_a=+25^{\circ}C$, $Z_s=Z_l=50ohm$

PARAMETERS	SYMBOL	CONDITIONS	MIN	TYP	MAX	UNITS
Small signal gain3	Gain3	Exclude PCB & connector losses (IN: 0.06dB, OUT: 0.16dB)	14.5	16.5	18.5	dB
Noise figure3	NF3	Exclude PCB & connector losses (IN: 0.06dB)	-	1.50	1.70	dB
Pin at 1dB gain compression point3	P-1dB(IN)3		-16.0	-9.0	-	dBm
Input 3rd order intercept point3	IIP3_3	$f1=f_{RF}$, $f2=f_{RF}+100kHz$, Pin=30dBm	-8.0	-1.0	-	dBm
RF Input VSWR3	VSWRi3		-	1.5	2.0	
RF Output VSWR3	VSWRo3		-	1.5	2.1	

■ELECTRICAL CHARACTERISTICS 5 (800MHz Band Low Gain Mode)

GENERAL CONDITIONS: $V_{DD}=V_{INV}=2.7V$, $V_{CTL1}=1.85V$, $V_{CTL2}=0V$, $V_{CTL3}=0V$, $f_{RF}=885MHz$,
 $T_a=+25^{\circ}C$, $Z_s=Z_l=50ohm$

PARAMETERS	SYMBOL	CONDITIONS	MIN	TYP	MAX	UNITS
Small signal gain4	Gain4	Exclude PCB & connector losses (IN: 0.06dB, OUT: 0.16dB)	-8.5	-6.5	-4.5	dB
Noise figure4	NF4	Exclude PCB & connector losses (IN: 0.06dB)	-	6.5	9.5	dB
Pin at 1dB gain compression point4	P-1dB(IN)4		+3.5	+11.0	-	dBm
Input 3rd order intercept point4	IIP3_4	$f1=f_{RF}$, $f2=f_{RF}+100kHz$, Pin=-20dBm	0.0	+12.0	-	dBm
RF Input VSWR4	VSWRi4		-	2.0	2.5	
RF Output VSWR4	VSWRo4		-	1.9	2.2	

■ELECTRICAL CHARACTERISTICS 6 (1.7GHZ Band High Gain Mode)

GENERAL CONDITIONS: $V_{DD}=V_{INV}=2.7V$, $V_{CTL1}=0V$, $V_{CTL2}=1.85V$, $V_{CTL3}=1.85V$, $f_{RF}=1860MHz$,
 $T_a=+25^{\circ}C$, $Z_s=Z_l=50\Omega$

PARAMETERS	SYMBOL	CONDITIONS	MIN	TYP	MAX	UNITS
Small signal gain5	Gain5	Exclude PCB & connector losses (IN: 0.10dB, OUT: 0.31dB)	15.5	17.5	19.0	dB
Noise figure5	NF5	Exclude PCB & connector losses (IN: 0.10dB)	-	1.65	1.80	dB
Pin at 1dB gain compression point5	P-1dB(IN)5		-16.0	-11.5	-	dBm
Input 3rd order intercept point5	IIP3_5	$f_1=f_{RF}$, $f_2=f_{RF}+100kHz$, Pin=-30dBm	-6.0	+1.0	-	dBm
RF Input VSWR5	VSWRi5		-	2.0	2.6	
RF Output VSWR5	VSWRo5		-	1.9	2.4	

■ELECTRICAL CHARACTERISTICS 6 (1.7GHZ Band Low Gain Mode)

GENERAL CONDITIONS: $V_{DD}=V_{INV}=2.7V$, $V_{CTL1}=0V$, $V_{CTL2}=1.85V$, $V_{CTL3}=0V$, $f_{RF}=1860MHz$,
 $T_a=+25^{\circ}C$, $Z_s=Z_l=50\Omega$

PARAMETERS	SYMBOL	CONDITIONS	MIN	TYP	MAX	UNITS
Small signal gain6	Gain6	Exclude PCB & connector losses (IN: 0.10dB, OUT: 0.31dB)	-11.5	-9.0	-7.0	dB
Noise figure6	NF6	Exclude PCB & connector losses (IN: 0.10dB)	-	9.5	12.0	dB
Pin at 1dB gain compression point6	P-1dB(IN)6		+4.0	+12.5	-	dBm
Input 3rd order intercept point6	IIP3_6	$f_1=f_{RF}$, $f_2=f_{RF}+100kHz$, Pin=-16dBm	0.0	+14.0	-	dBm
RF Input VSWR6	VSWRi6		-	1.7	2.3	
RF Output VSWR6	VSWRo6		-	1.4	2.0	

■TERMINAL INFORMATION

No.	SYMBOL	DESCRIPTION
1	GND	Ground terminal. (0V)
2	VINV	Inverter voltage supplies terminal.
3	VCTL3	Control voltage supply terminal. The high level voltage of this terminal selects High Gain Mode. The low level voltage of this terminal selects Low Gain Mode.
4	RFOUT3	Output terminal of 1.7GHz band. This terminal is also the power supply terminal of the LNA, please use inductor (L10) to connect power supply.
5	GND	Ground terminal. (0V)
6	RFOUT2	Output terminal of 2.1GHz band. This terminal is also the power supply terminal of the LNA, please use inductor (L6) to connect power supply.
7	GND	Ground terminal. (0V)
8	RFOUT1	Output terminal of 800MHz band. This terminal is also the power supply terminal of the LNA, please use inductor (L3) to connect power supply.
9	VCTL2	Control voltage supply terminal. The frequency band (2Ghz / 800MHz / 1.7GHz) selects by 2bit control signal. (Please refer to truth table.)
10	VCTL1	
11	GND	Ground terminal. (0V)
12	RFIN1	RF input terminal of 800MHz band. The RF signal is input through external matching circuit connected to this terminal. The DC blocking capacitor is not required.
13	GND	Ground terminal. (0V)
14	RFIN2	RF input terminal of 2.1GHz band. The RF signal is input through external matching circuit connected to this terminal. The DC blocking capacitor is not required.
15	GND	Ground terminal. (0V)
16	RFIN3	RF input terminal of 1.7GHz band. The RF signal is input through external matching circuit connected to this terminal. The DC blocking capacitor is not required.

CAUTION

- 1) Ground terminal (1, 5, 7, 11, 13, 15) should be connected to the ground plane as low inductance as possible.

■ TRUTH TABLE

Control voltage			Operating state					
V _{CTL1} (Band Sel1)	V _{CTL2} (Band Sel2)	V _{CTL3} (Gain Sel1)	2.1GHz Band		800MHz Band		1.7GHz Band	
			LNA	Bypass	LNA	Bypass	LNA	Bypass
L	L	L	OFF	ON	OFF	ON	OFF	ON
L	L	H	ON	OFF	OFF	OFF	OFF	OFF
H	L	L	OFF	ON	OFF	ON	OFF	ON
H	L	H	OFF	OFF	ON	OFF	OFF	OFF
L	H	L	OFF	ON	OFF	ON	OFF	ON
L	H	H	OFF	OFF	OFF	OFF	ON	OFF
H	H	L	Don't Care					
H	H	H						

“L”=0 ~ 0.3V, “H”=1.52 ~ V_{INV}+0.3 V

NJG1125PB5

■ ELECTRICAL CHARACTERISTICS (2.1GHz Band High Gain Mode)

**2.1GHz@High Gain
Pout vs. Pin**

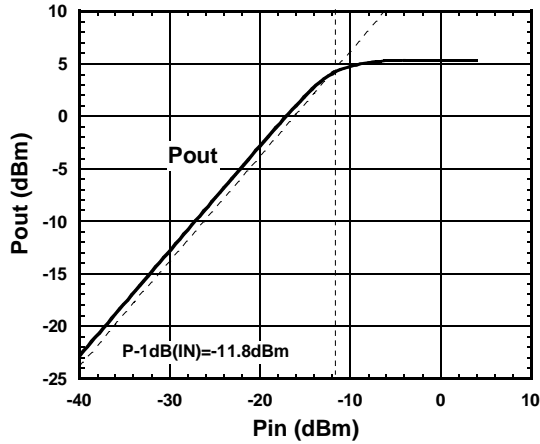

Condition
 $T_a = +25^\circ\text{C}$,
 $f = 2140\text{MHz}$,
 $V_{DD} = V_{INV} = 2.7\text{V}$,
 $V_{CTL1} = 0\text{V}$, $V_{CTL2} = 0\text{V}$, $V_{CTL3} = 1.85\text{V}$

**2.1GHz@High Gain
Gain, IDD vs. Pin**

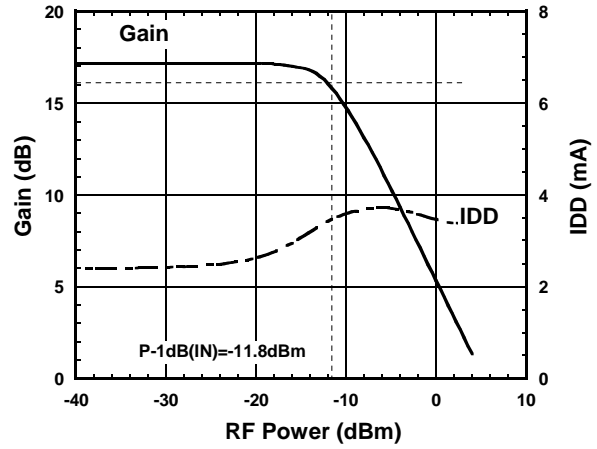

Condition
 $T_a = +25^\circ\text{C}$,
 $f = 2140\text{MHz}$,
 $V_{DD} = V_{INV} = 2.7\text{V}$,
 $V_{CTL1} = 0\text{V}$, $V_{CTL2} = 0\text{V}$, $V_{CTL3} = 1.85\text{V}$

**2.1GHz@High Gain
NF vs. frequency**

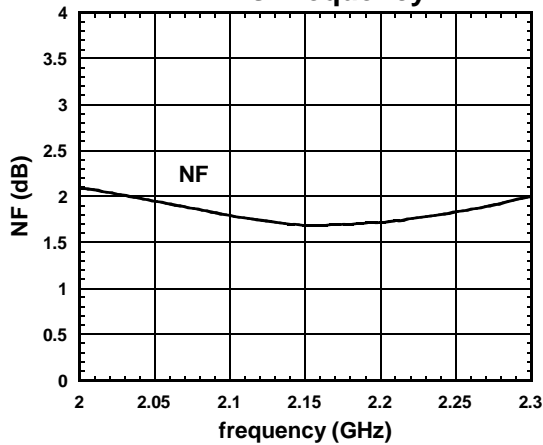

Condition
 $T_a = +25^\circ\text{C}$,
 $f = 2 \sim 2.3\text{GHz}$,
 $V_{DD} = V_{INV} = 2.7\text{V}$,
 $V_{CTL1} = 0\text{V}$, $V_{CTL2} = 0\text{V}$, $V_{CTL3} = 1.85\text{V}$

**2.1GHz@High Gain
Pout, IM3 vs. Pin**

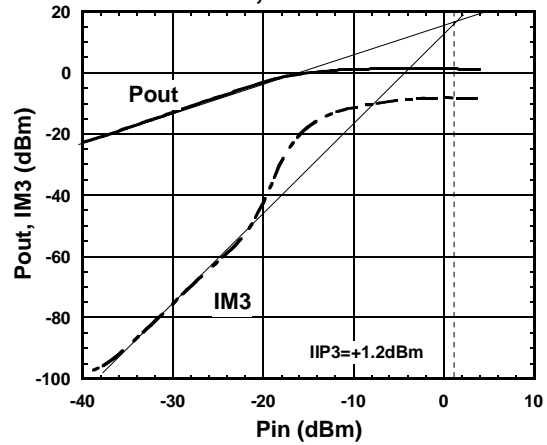

Condition
 $T_a = +25^\circ\text{C}$,
 $f_1 = 2140\text{MHz}$, $f_2 = f_1 + 100\text{kHz}$,
 $V_{DD} = V_{INV} = 2.7\text{V}$,
 $V_{CTL1} = 0\text{V}$, $V_{CTL2} = 0\text{V}$, $V_{CTL3} = 1.85\text{V}$

■ ELECTRICAL CHARACTERISTICS (2.1GHz Band High Gain Mode)

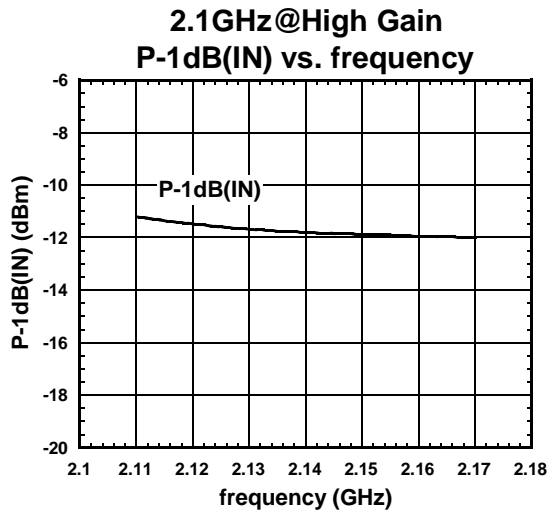

Condition

$T_a = +25^\circ\text{C}$,
 $f = 2.1 \sim 2.2\text{GHz}$,
 $V_{DD} = V_{INV} = 2.7\text{V}$,
 $V_{CTL1} = 0\text{V}$, $V_{CTL2} = 0\text{V}$, $V_{CTL3} = 1.85\text{V}$

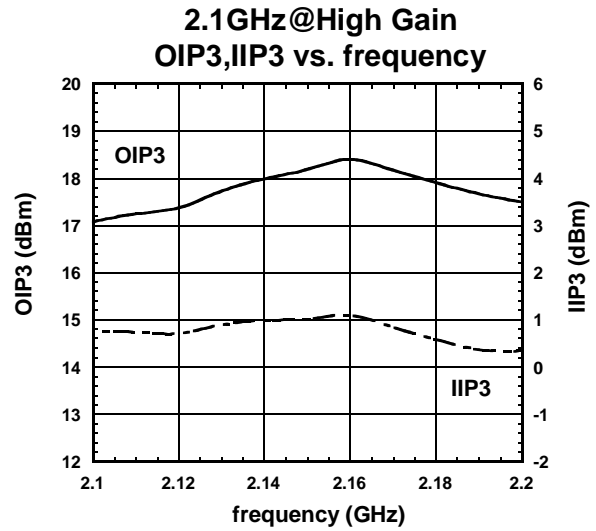

Condition

$T_a = +25^\circ\text{C}$,
 $f_1 = 2.1 \sim 2.2\text{GHz}$, $f_2 = f_1 + 100\text{kHz}$,
 $\text{Pin} = -30\text{dBm}$,
 $V_{DD} = V_{INV} = 2.7\text{V}$,
 $V_{CTL1} = 0\text{V}$, $V_{CTL2} = 0\text{V}$, $V_{CTL3} = 1.85\text{V}$

NJG1125PB5

ELECTRICAL CHARACTERISTICS (2.1GHz Band High Gain Mode)

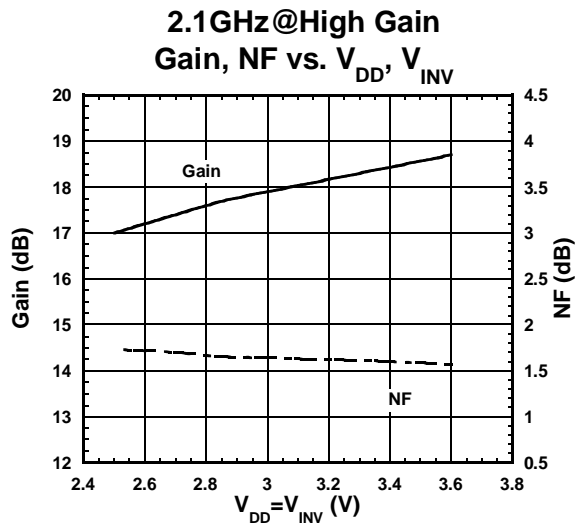

Condition
 $T_a = +25^\circ\text{C}$,
 $f = 2140\text{MHz}$,
 $V_{CTL1} = 0\text{V}$, $V_{CTL2} = 0\text{V}$, $V_{CTL3} = 1.85\text{V}$

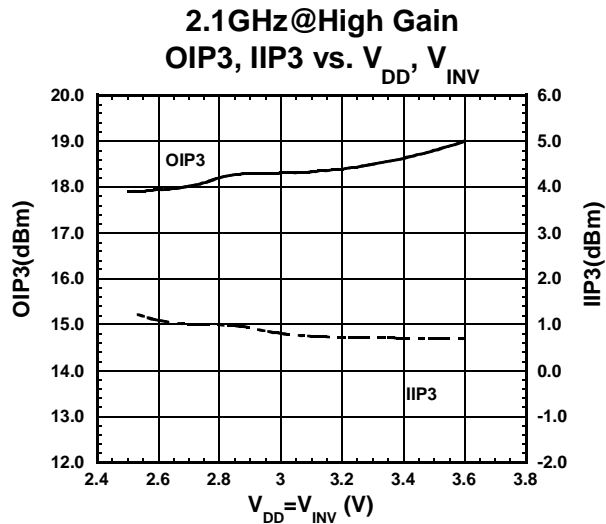

Condition
 $T_a = +25^\circ\text{C}$,
 $f_1 = 2140\text{MHz}$, $f_2 = f_1 + 100\text{kHz}$,
 $P_{in} = -30\text{dBm}$,
 $V_{CTL1} = 0\text{V}$, $V_{CTL2} = 0\text{V}$, $V_{CTL3} = 1.85\text{V}$

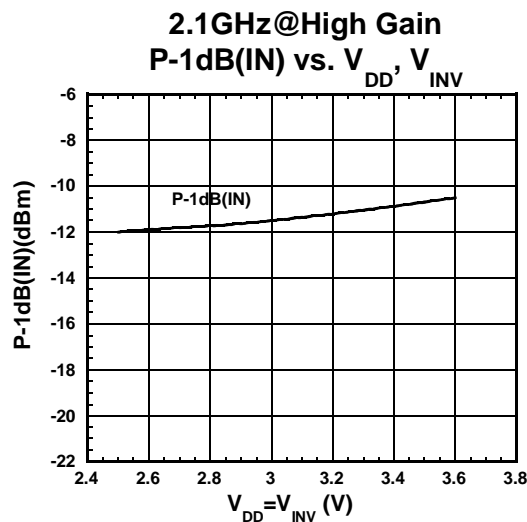

Condition
 $T_a = +25^\circ\text{C}$,
 $f = 2140\text{MHz}$,
 $V_{CTL1} = 0\text{V}$, $V_{CTL2} = 0\text{V}$, $V_{CTL3} = 1.85\text{V}$

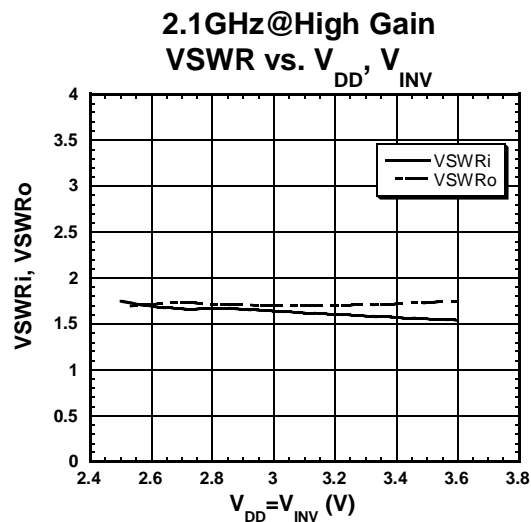

Condition
 $T_a = +25^\circ\text{C}$,
 $f = 2140\text{MHz}$,
 $V_{CTL1} = 0\text{V}$, $V_{CTL2} = 0\text{V}$, $V_{CTL3} = 1.85\text{V}$

■ ELECTRICAL CHARACTERISTICS (2.1GHz Band High Gain Mode)

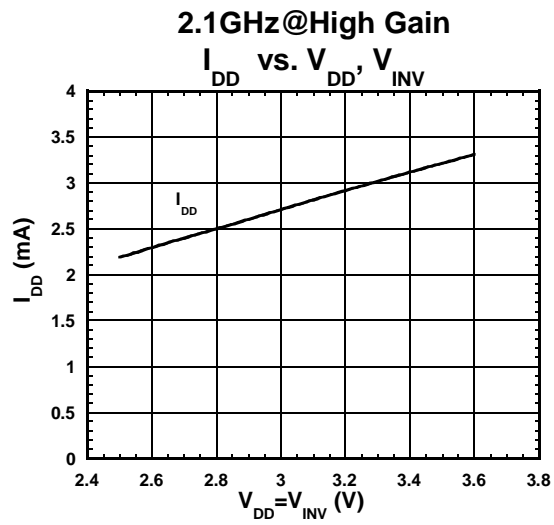

Condition

$T_a = +25^\circ\text{C}$,

RF=OFF,

$V_{CTL1} = 0\text{V}$, $V_{CTL2} = 0\text{V}$, $V_{CTL3} = 1.85\text{V}$

NJG1125PB5

ELECTRICAL CHARACTERISTICS (2.1GHz Band High Gain Mode)

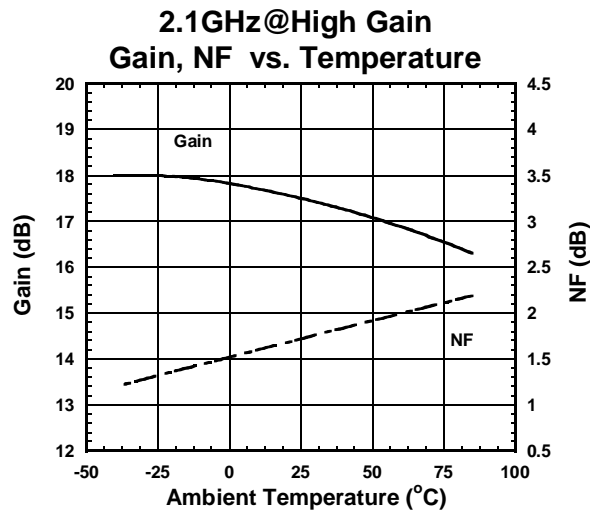

Condition

$f=2140\text{MHz}$,
 $V_{DD}=V_{INV}=2.7\text{V}$,
 $V_{CTL1}=0\text{V}$, $V_{CTL2}=0\text{V}$, $V_{CTL3}=1.85\text{V}$

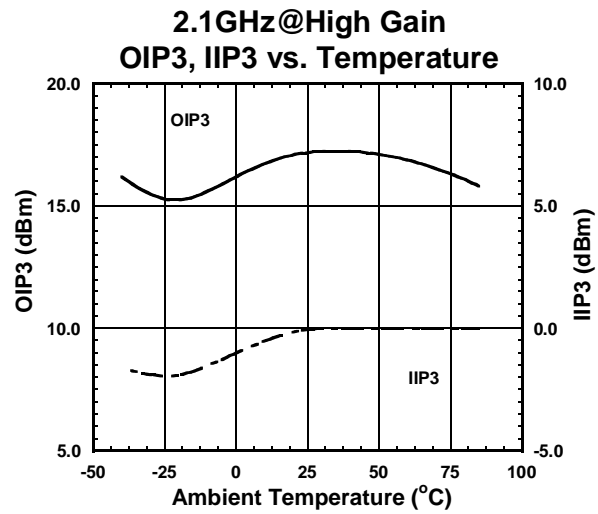

Condition

$f_1=2140\text{MHz}$, $f_2=f_1+100\text{kHz}$,
 $P_{in}=-30\text{dBm}$,
 $V_{DD}=V_{INV}=2.7\text{V}$,
 $V_{CTL1}=0\text{V}$, $V_{CTL2}=0\text{V}$, $V_{CTL3}=1.85\text{V}$

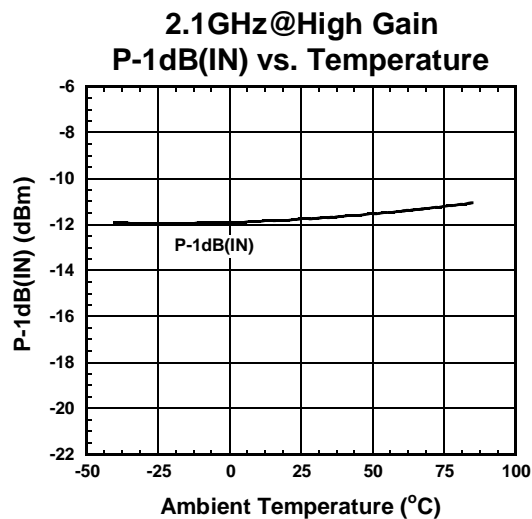

Condition

$f=2140\text{MHz}$,
 $V_{DD}=V_{INV}=2.7\text{V}$,
 $V_{CTL1}=0\text{V}$, $V_{CTL2}=0\text{V}$, $V_{CTL3}=1.85\text{V}$

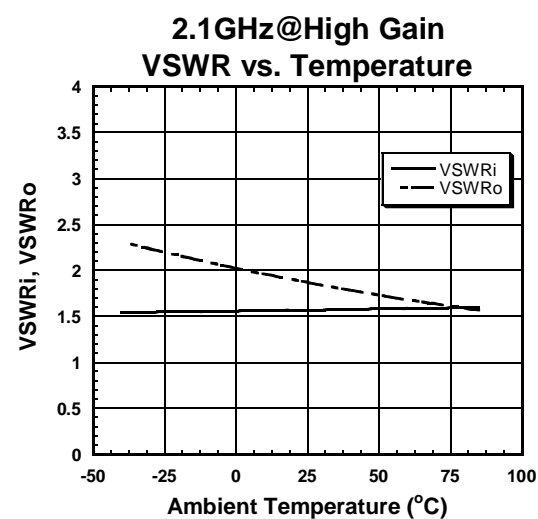

Condition

$f=2140\text{MHz}$,
 $V_{DD}=V_{INV}=2.7\text{V}$,
 $V_{CTL1}=0\text{V}$, $V_{CTL2}=0\text{V}$, $V_{CTL3}=1.85\text{V}$

■ ELECTRICAL CHARACTERISTICS (2.1GHz Band High Gain Mode)

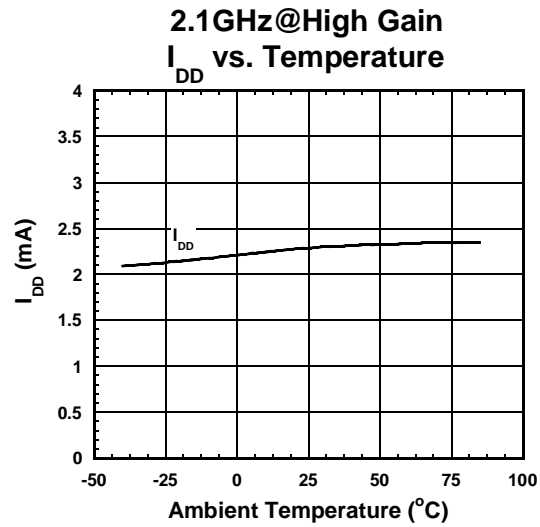

Condition

RF=OFF,

$V_{DD} = V_{INV} = 2.7V$

$V_{CTL1} = 0V, V_{CTL2} = 0V, V_{CTL3} = 1.85V$

NJG1125PB5

ELECTRICAL CHARACTERISTICS (2.1GHz Band High Gain Mode)

Condition: $T_a=+25^{\circ}\text{C}$, $V_{DD}=V_{INV}=2.7\text{V}$, $V_{CTL1}=0\text{V}$, $V_{CTL2}=0\text{V}$, $V_{CTL3}=1.85\text{V}$

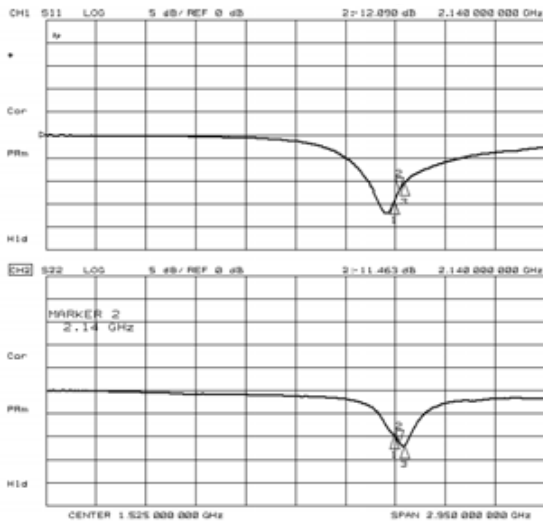

S11, S22

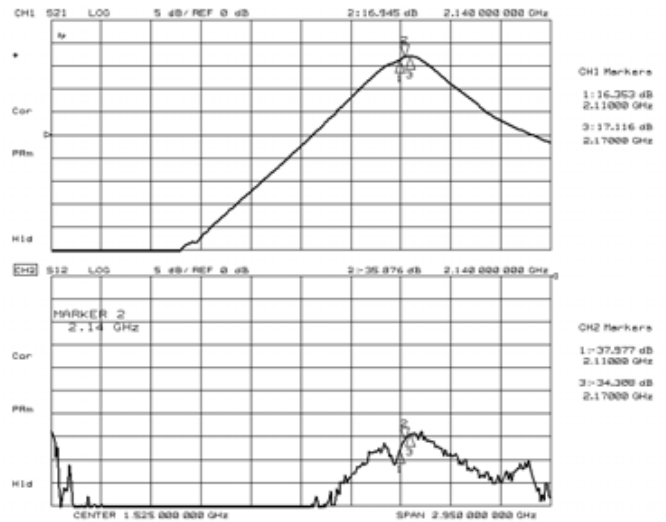

S 21, S12

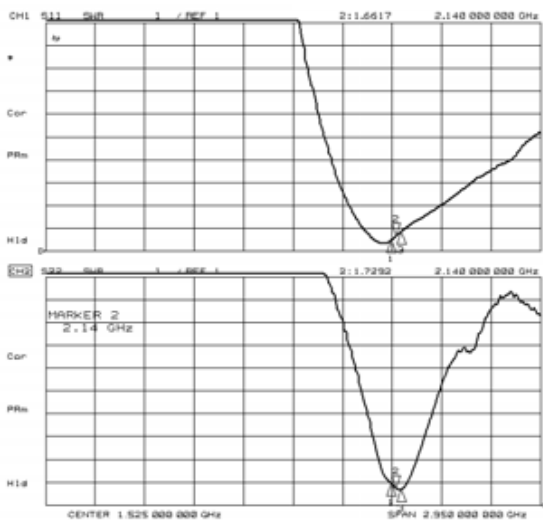

VSWR

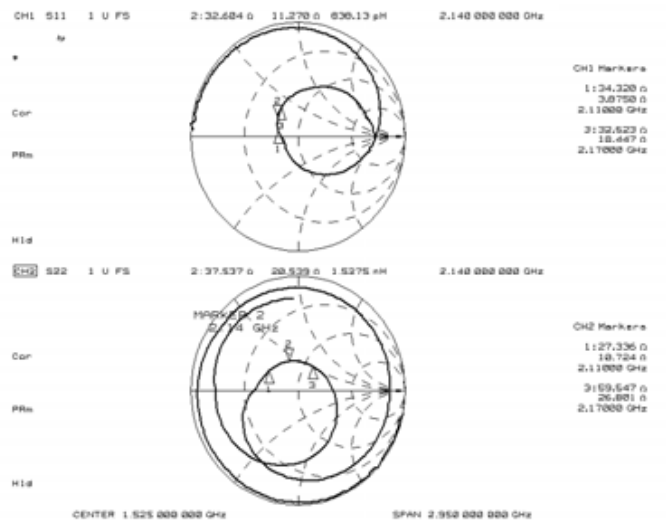

Zin, Zout

■ ELECTRICAL CHARACTERISTICS (2.1GHz Band High Gain Mode)

Condition: $T_a=+25^{\circ}\text{C}$, $V_{DD}=V_{INV}=2.7\text{V}$, $V_{CTL1}=0\text{V}$, $V_{CTL2}=0\text{V}$, $V_{CTL3}=1.85\text{V}$

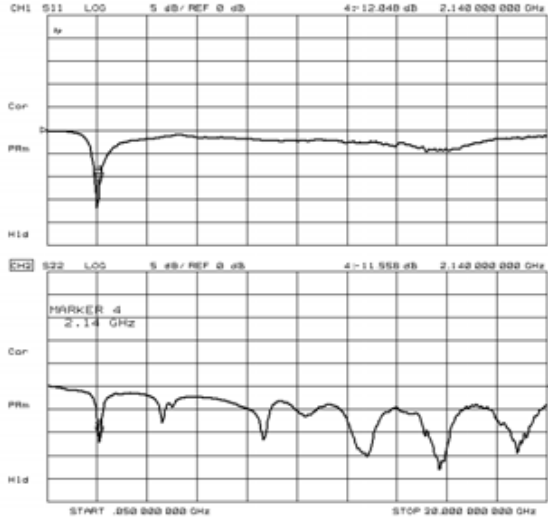

S11, S22
($f=50\text{MHz}\sim 20\text{GHz}$)

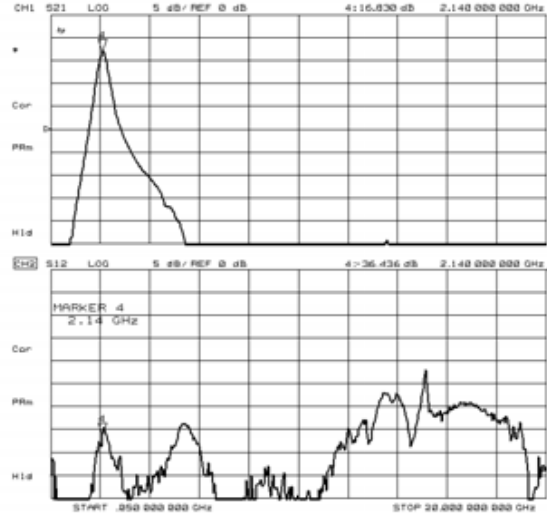

S21, S12
($f=50\text{MHz}\sim 20\text{GHz}$)

2.1GHz @High Gain k factor vs. frequency

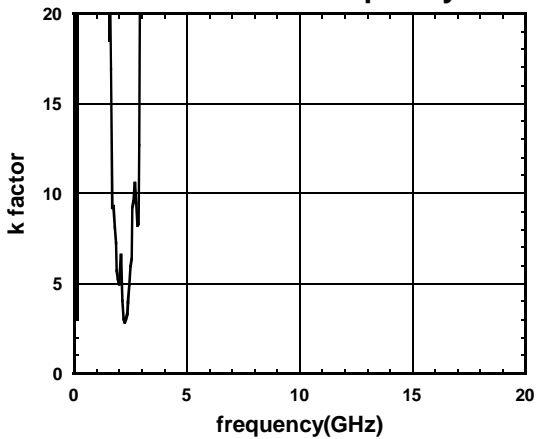

k factor
($f=50\text{MHz}\sim 20\text{GHz}$)

NJG1125PB5

■ ELECTRICAL CHARACTERISTICS (2.1GHz Band Low Gain Mode)

**2.1GHz@Low Gain
Pout vs. Pin**

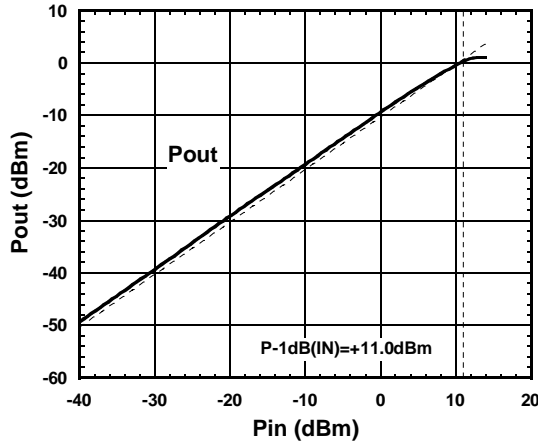

Condition
 $T_a = +25^\circ\text{C}$,
 $f = 2140\text{MHz}$,
 $V_{DD} = V_{INV} = 2.7\text{V}$,
 $V_{CTL1} = 0\text{V}$, $V_{CTL2} = 0\text{V}$, $V_{CTL3} = 0\text{V}$

**2.1GHz@Low Gain
Gain, IDD vs. Pin**

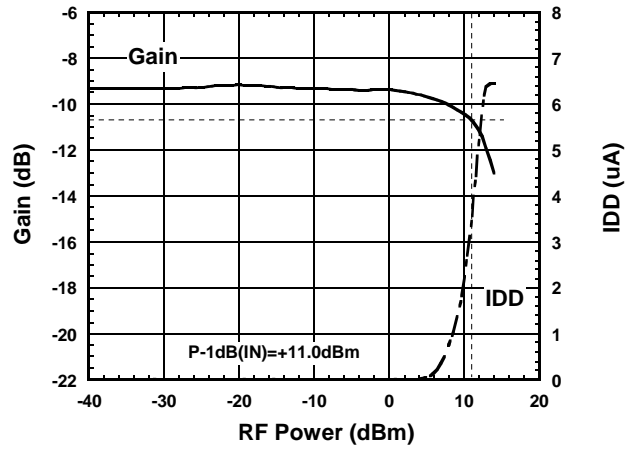

Condition
 $T_a = +25^\circ\text{C}$,
 $f = 2140\text{MHz}$,
 $V_{DD} = V_{INV} = 2.7\text{V}$,
 $V_{CTL1} = 0\text{V}$, $V_{CTL2} = 0\text{V}$, $V_{CTL3} = 0\text{V}$

**2.1GHz@Low Gain
NF vs. frequency**

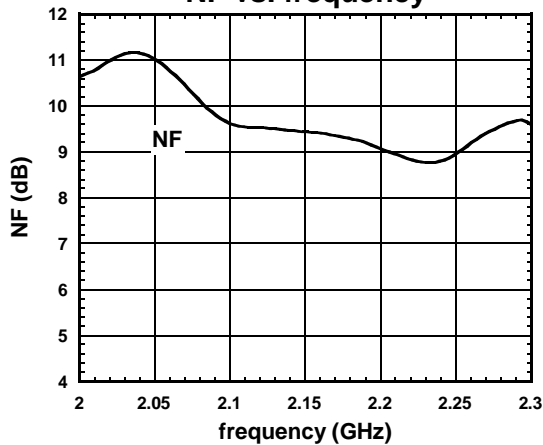

Condition
 $T_a = +25^\circ\text{C}$,
 $f = 2 \sim 2.3\text{GHz}$,
 $V_{DD} = V_{INV} = 2.7\text{V}$,
 $V_{CTL1} = 0\text{V}$, $V_{CTL2} = 0\text{V}$, $V_{CTL3} = 0\text{V}$

**2.1GHz@Low Gain
Pout, IM3 vs. Pin**

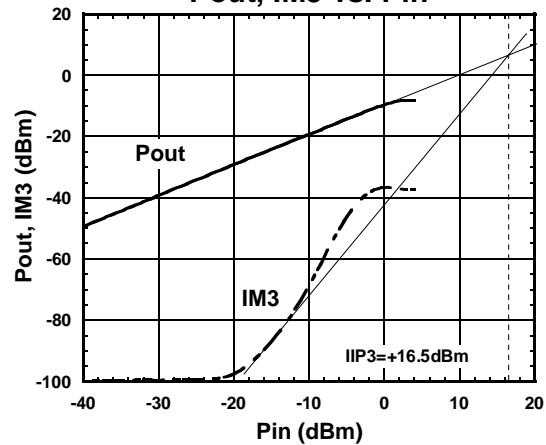

Condition
 $T_a = +25^\circ\text{C}$,
 $f1 = 2140\text{MHz}$, $f2 = f1 + 100\text{kHz}$,
 $V_{DD} = V_{INV} = 2.7\text{V}$,
 $V_{CTL1} = 0\text{V}$, $V_{CTL2} = 0\text{V}$, $V_{CTL3} = 0\text{V}$

■ ELECTRICAL CHARACTERISTICS (2.1GHz Band Low Gain Mode)

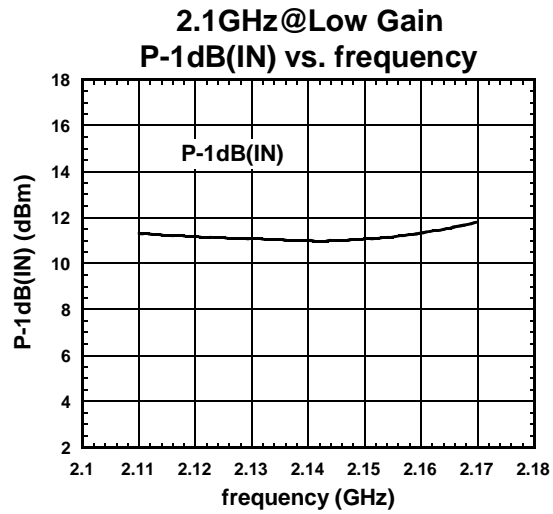

Condition

$T_a = +25^\circ\text{C}$,
 $f = 2.1 \sim 2.2\text{GHz}$,
 $V_{DD} = V_{INV} = 2.7\text{V}$,
 $V_{CTL1} = 0\text{V}$, $V_{CTL2} = 0\text{V}$, $V_{CTL3} = 0\text{V}$

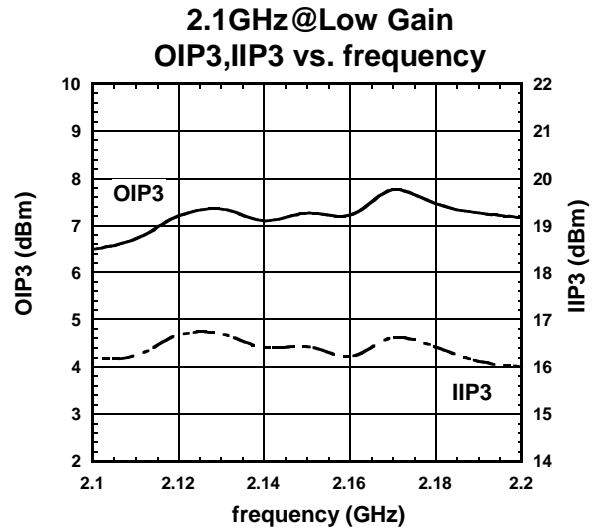

Condition

$T_a = +25^\circ\text{C}$,
 $f_1 = 2.1 \sim 2.2\text{GHz}$, $f_2 = f_1 + 100\text{kHz}$,
 $\text{Pin} = -16\text{dBm}$,
 $V_{DD} = V_{INV} = 2.7\text{V}$,
 $V_{CTL1} = 0\text{V}$, $V_{CTL2} = 0\text{V}$, $V_{CTL3} = 0\text{V}$

NJG1125PB5

ELECTRICAL CHARACTERISTICS (2.1GHz Band Low Gain Mode)

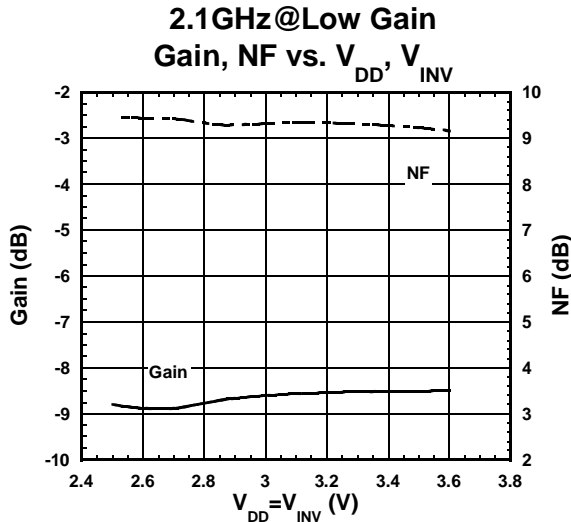

Condition
 Ta=+25°C,
 f=2140MHz,
 V_{CTL1}=0V, V_{CTL2}=0V, V_{CTL3}=0V

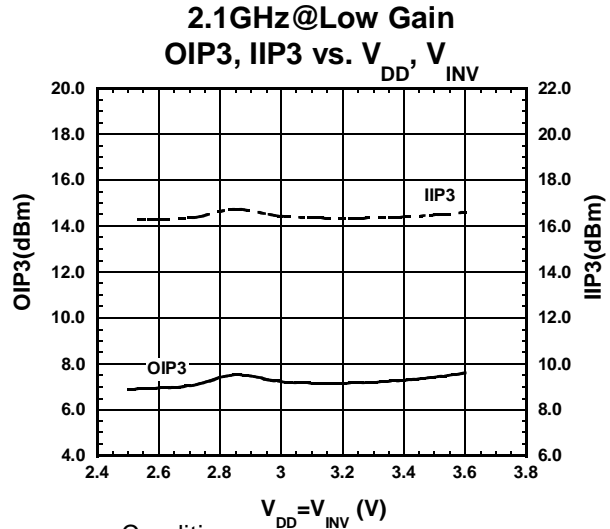

Condition
 Ta=+25°C,
 f1=2140MHz, f2=f1+100kHz,
 Pin=-16dBm,
 V_{CTL1}=0V, V_{CTL2}=0V, V_{CTL3}=0V

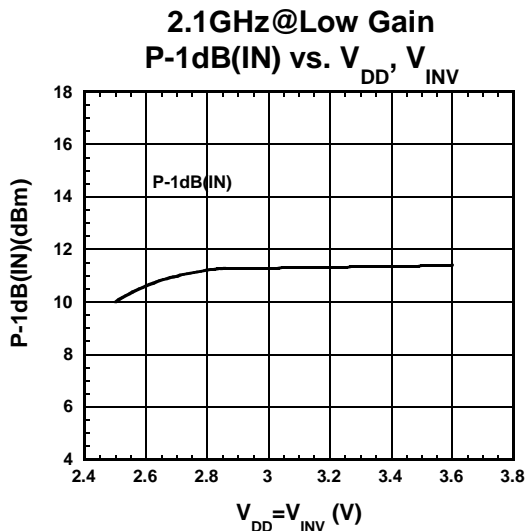

Condition
 Ta=+25°C,
 f=2140MHz,
 V_{CTL1}=0V, V_{CTL2}=0V, V_{CTL3}=0V

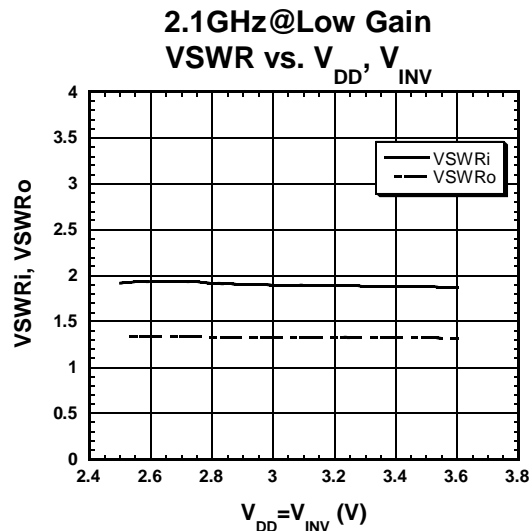

Condition
 Ta=+25°C,
 f=2140MHz,
 V_{CTL1}=0V, V_{CTL2}=0V, V_{CTL3}=0V

■ ELECTRICAL CHARACTERISTICS (2.1GHz Band Low Gain Mode)

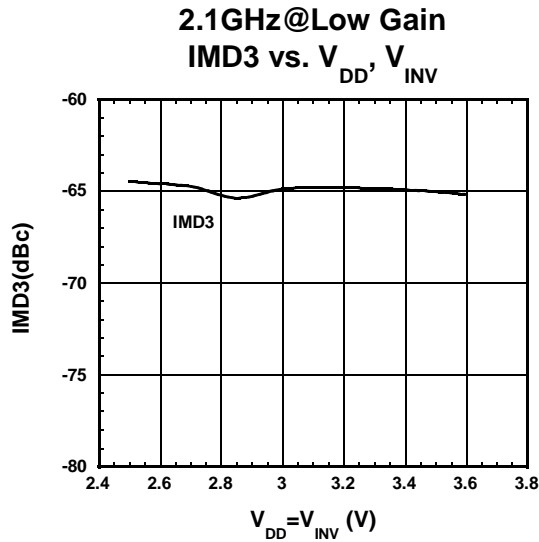

Condition

$T_a = +25^\circ\text{C}$,
 $f_1 = 2140\text{MHz}$, $f_2 = f_1 + 2140.1\text{MHz}$,
 $P_{in} = -16\text{dBm}$,
 $V_{CTL1} = 0\text{V}$, $V_{CTL2} = 0\text{V}$, $V_{CTL3} = 0\text{V}$

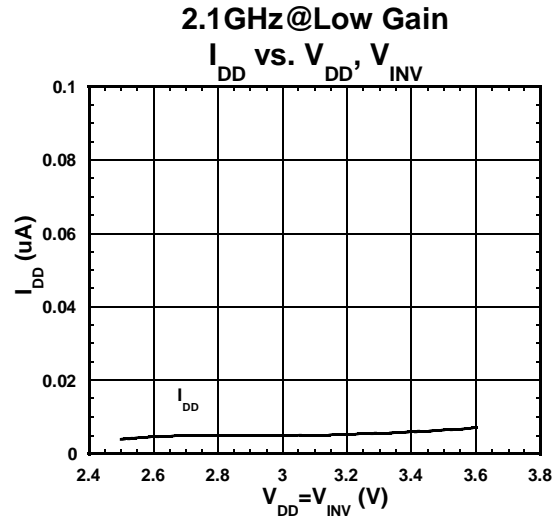

Condition

$T_a = +25^\circ\text{C}$,
 $\text{RF} = \text{OFF}$,
 $V_{CTL1} = 0\text{V}$, $V_{CTL2} = 0\text{V}$, $V_{CTL3} = 0\text{V}$

ELECTRICAL CHARACTERISTICS (2.1GHz Band Low Gain Mode)

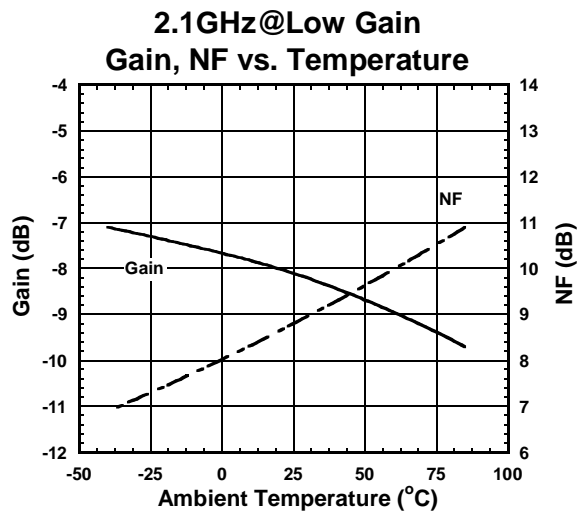

Condition
 $f=2140\text{MHz}$,
 $V_{DD}=V_{INV}=2.7\text{V}$,
 $V_{CTL1}=0\text{V}$, $V_{CTL2}=0\text{V}$, $V_{CTL3}=0\text{V}$

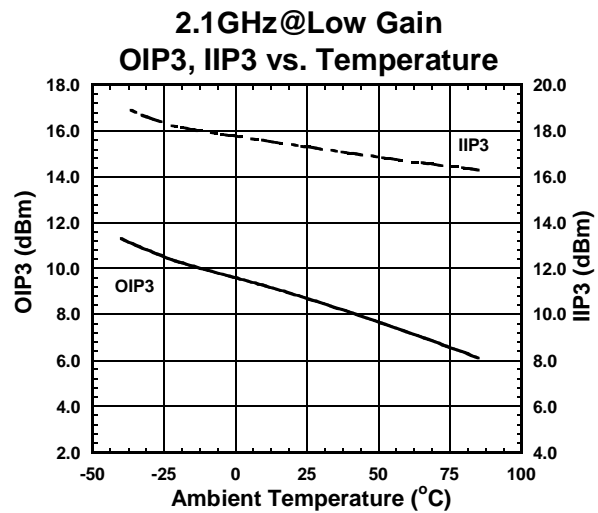

Condition
 $f1=2140\text{MHz}$, $f2=f1+100\text{kHz}$,
 $\text{Pin}=-16\text{dBm}$,
 $V_{DD}=V_{INV}=2.7\text{V}$
 $V_{CTL1}=0\text{V}$, $V_{CTL2}=0\text{V}$, $V_{CTL3}=0\text{V}$

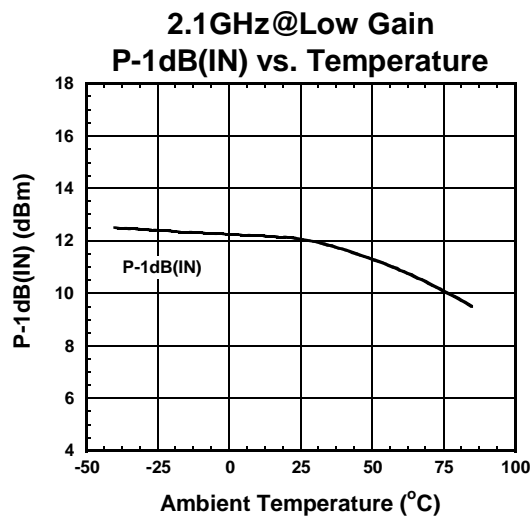

Condition
 $f=2140\text{MHz}$,
 $V_{DD}=V_{INV}=2.7\text{V}$
 $V_{CTL1}=0\text{V}$, $V_{CTL2}=0\text{V}$, $V_{CTL3}=0\text{V}$

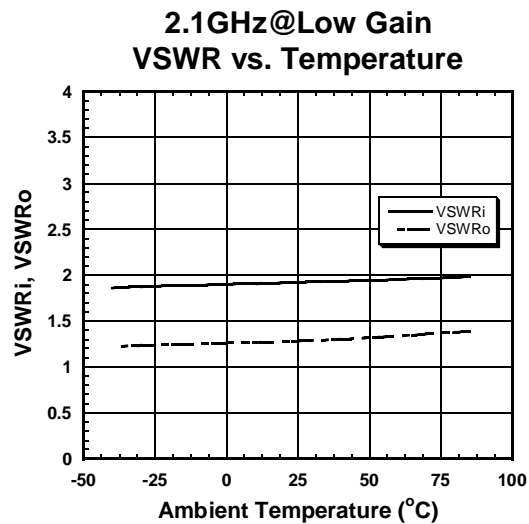

Condition
 $f=2140\text{MHz}$,
 $V_{DD}=V_{INV}=2.7\text{V}$
 $V_{CTL1}=0\text{V}$, $V_{CTL2}=0\text{V}$, $V_{CTL3}=0\text{V}$

■ ELECTRICAL CHARACTERISTICS (2.1GHz Band Low Gain Mode)

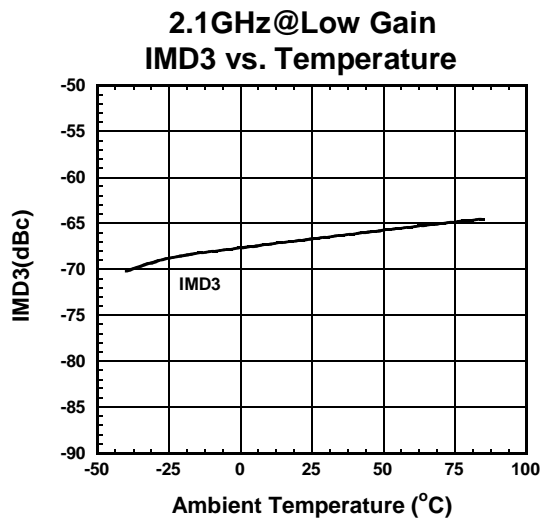

Condition
 $f_1=2140\text{MHz}$, $f_2=f_1+100\text{kHz}$,
 $P_{in}=-16\text{dBm}$,
 $V_{DD}=V_{INV}=2.7\text{V}$
 $V_{CTL1}=0\text{V}$, $V_{CTL2}=0\text{V}$, $V_{CTL3}=0\text{V}$

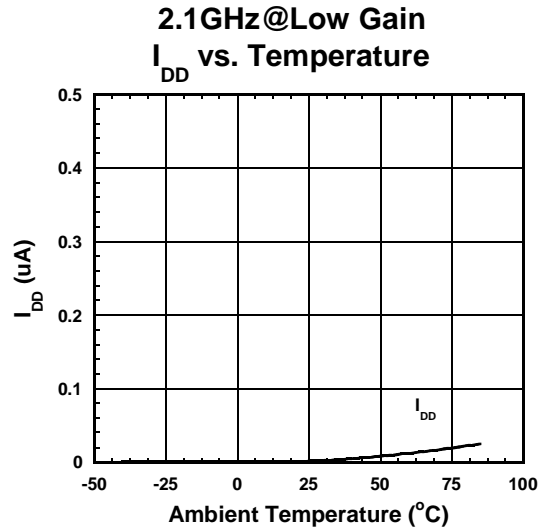

Condition
 $RF=OFF$,
 $V_{DD}=V_{INV}=2.7\text{V}$
 $V_{CTL1}=0\text{V}$, $V_{CTL2}=0\text{V}$, $V_{CTL3}=0\text{V}$

NJG1125PB5

ELECTRICAL CHARACTERISTICS (2.1GHz Band Low Gain Mode)

Condition: $T_a=+25^{\circ}\text{C}$, $V_{DD}=V_{INV}=2.7\text{V}$, $V_{CTL1}=0\text{V}$, $V_{CTL2}=0\text{V}$, $V_{CTL3}=0\text{V}$

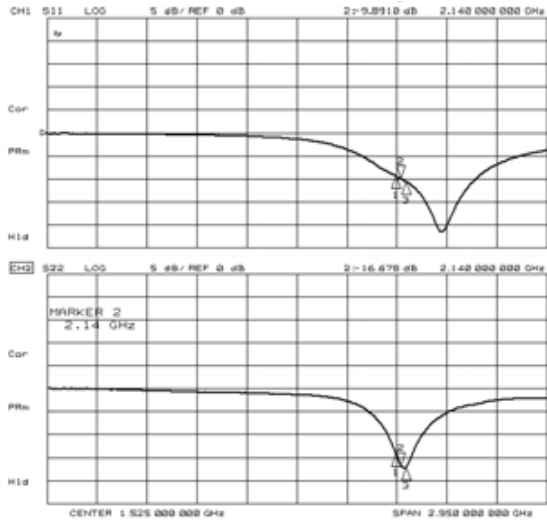

S11, S22

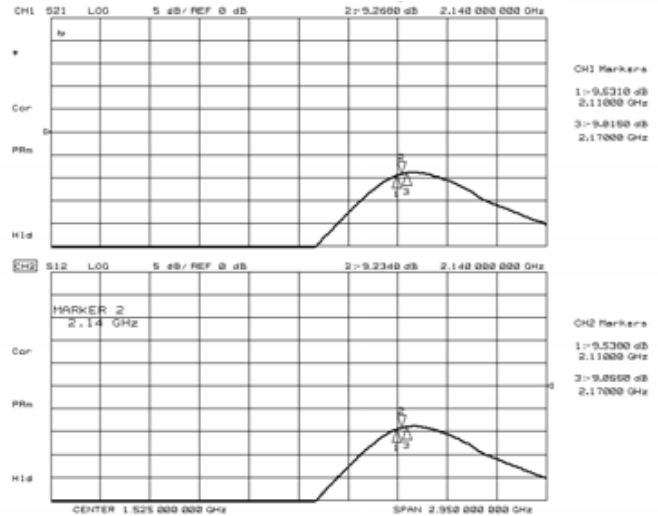

S21, S12

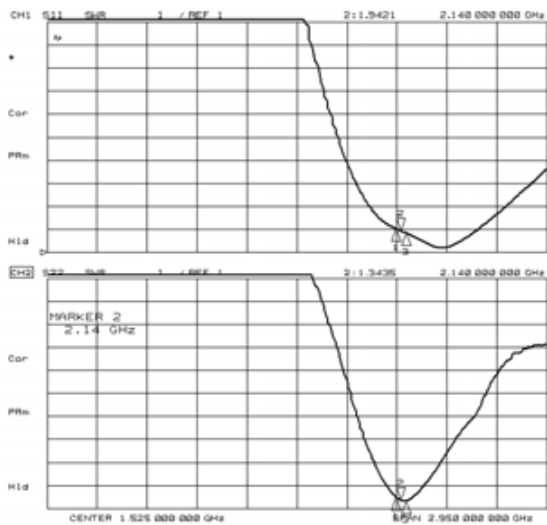

VSWR

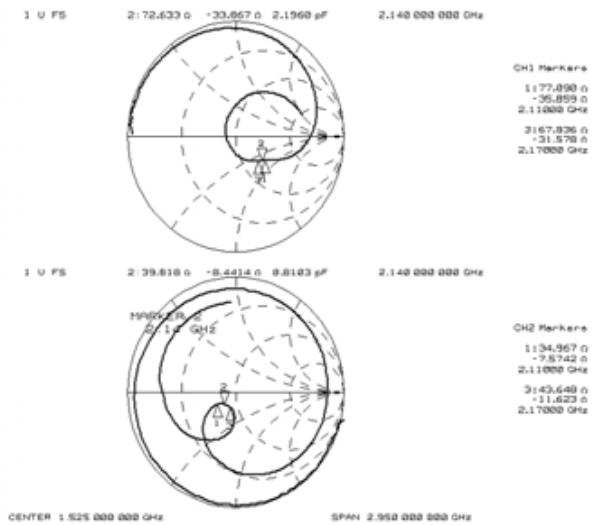

Zin, Zout

■ ELECTRICAL CHARACTERISTICS (2.1GHz Band Low Gain Mode)

Condition: $T_a=+25^{\circ}\text{C}$, $V_{DD}=V_{INV}=2.7\text{V}$, $V_{CTL1}=0\text{V}$, $V_{CTL2}=0\text{V}$, $V_{CTL3}=0\text{V}$

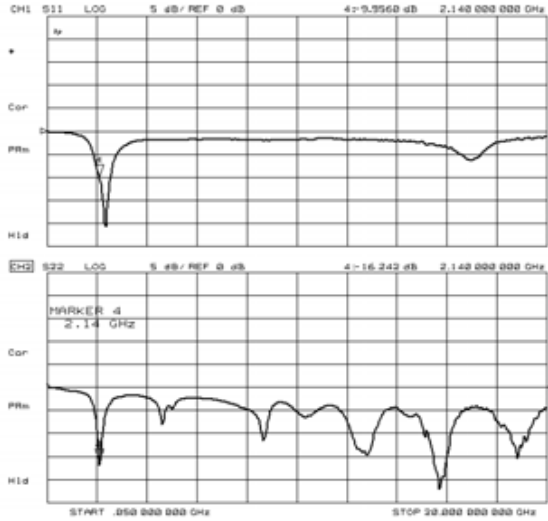

S11, S22
($f=50\text{MHz}\sim 20\text{GHz}$)

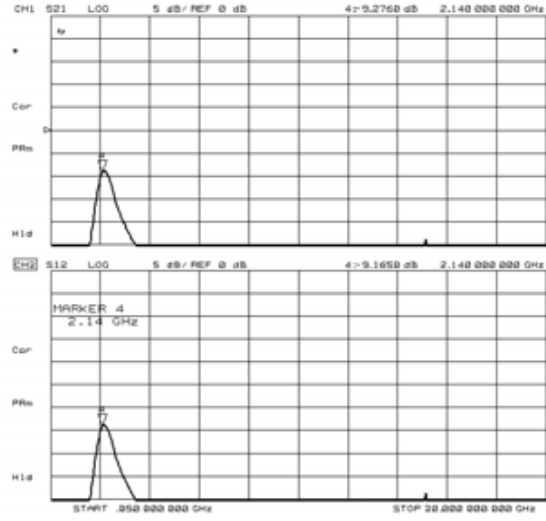

S21, S12
($f=50\text{MHz}\sim 20\text{GHz}$)

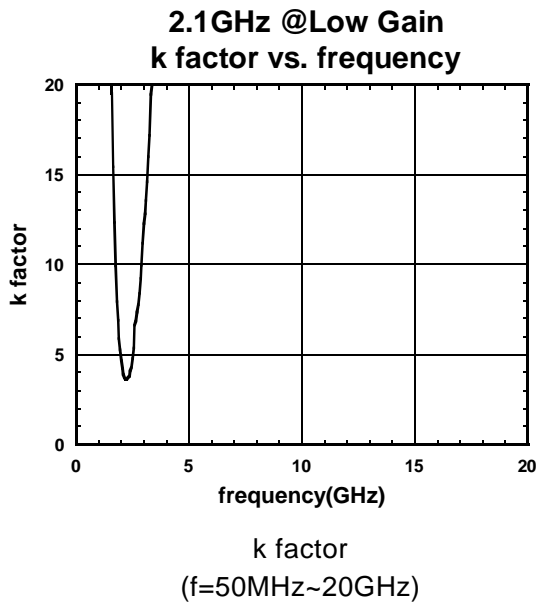

NJG1125PB5

■ ELECTRICAL CHARACTERISTICS (800MHz Band High Gain Mode)

**800MHz@High Gain
Pout vs. Pin**

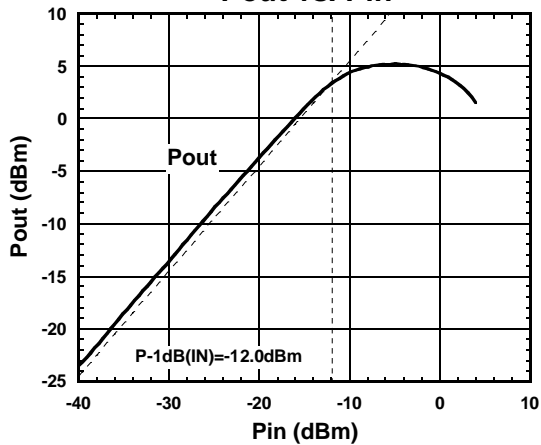

Condition

$T_a = +25^\circ\text{C}$,
 $f = 885\text{MHz}$,
 $V_{DD} = V_{INV} = 2.7\text{V}$,
 $V_{CTL1} = 1.85\text{V}$, $V_{CTL2} = 0\text{V}$, $V_{CTL3} = 1.85\text{V}$

**800MHz@High Gain
Gain, IDD vs. Pin**

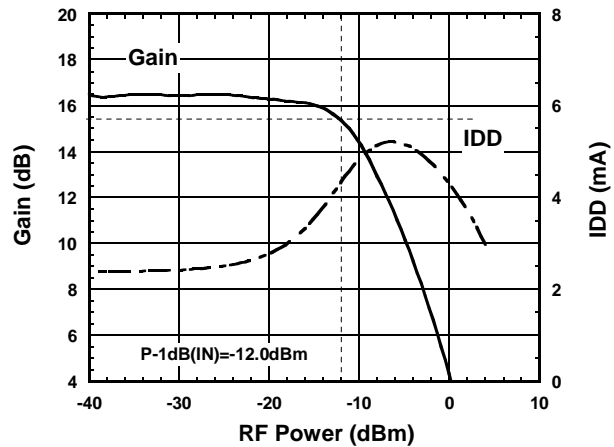

Condition

$T_a = +25^\circ\text{C}$,
 $f = 885\text{MHz}$,
 $V_{DD} = V_{INV} = 2.7\text{V}$,
 $V_{CTL1} = 1.85\text{V}$, $V_{CTL2} = 0\text{V}$, $V_{CTL3} = 1.85\text{V}$

**800MHz@High Gain
NF vs. frequency**

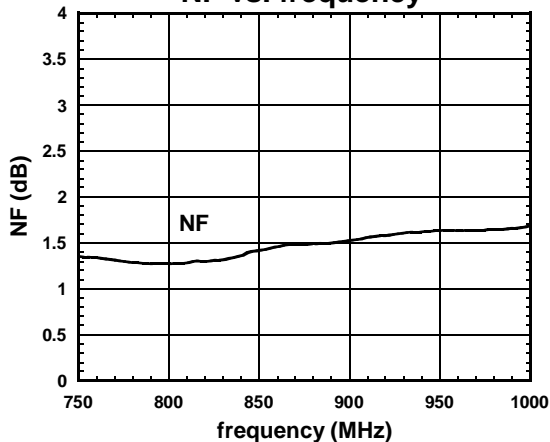

Condition

$T_a = +25^\circ\text{C}$,
 $f = 750\text{MHz} \sim 1\text{GHz}$,
 $V_{DD} = V_{INV} = 2.7\text{V}$,
 $V_{CTL1} = 1.85\text{V}$, $V_{CTL2} = 0\text{V}$, $V_{CTL3} = 1.85\text{V}$

**800MHz@High Gain
Pout, IM3 vs. Pin**

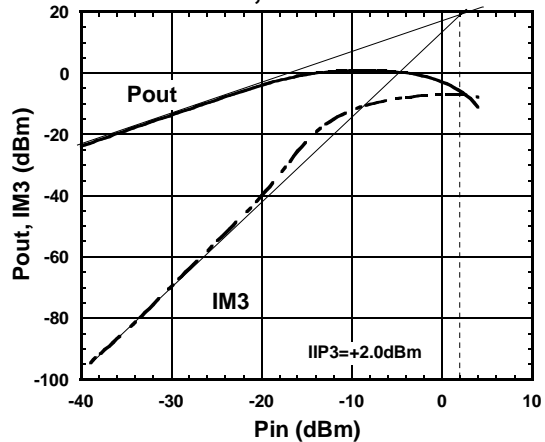

Condition

$T_a = +25^\circ\text{C}$,
 $f_1 = 885\text{MHz}$, $f_2 = f_1 + 100\text{kHz}$,
 $V_{DD} = V_{INV} = 2.7\text{V}$,
 $V_{CTL1} = 1.85\text{V}$, $V_{CTL2} = 0\text{V}$, $V_{CTL3} = 1.85\text{V}$

■ ELECTRICAL CHARACTERISTICS (800MHz Band High Gain Mode)

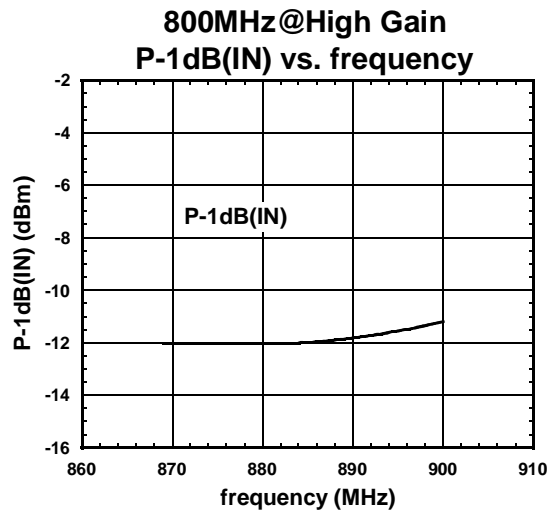

Condition

$T_a = +25^\circ\text{C}$,

$f = 869 \sim 900\text{MHz}$,

$V_{DD} = V_{INV} = 2.7\text{V}$,

$V_{CTL1} = 1.85\text{V}$, $V_{CTL2} = 0\text{V}$, $V_{CTL3} = 1.85\text{V}$

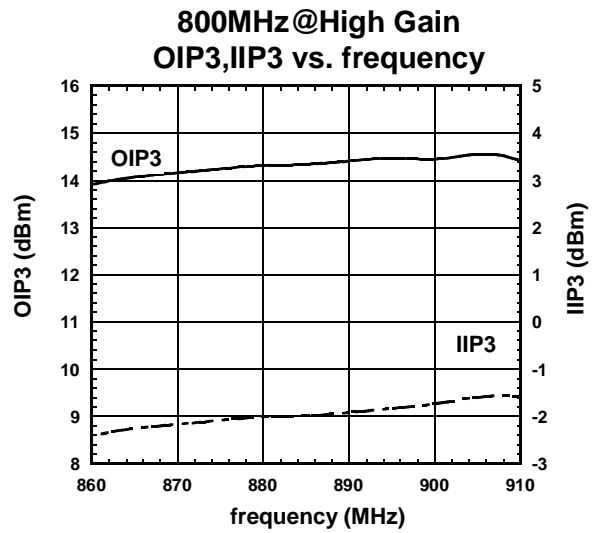

Condition

$T_a = +25^\circ\text{C}$,

$f_1 = 860 \sim 910\text{MHz}$, $f_2 = f_1 + 100\text{kHz}$,

$\text{Pin} = -30\text{dBm}$,

$V_{DD} = V_{INV} = 2.7\text{V}$,

$V_{CTL1} = 1.85\text{V}$, $V_{CTL2} = 0\text{V}$, $V_{CTL3} = 1.85\text{V}$

NJG1125PB5

■ ELECTRICAL CHARACTERISTICS (800MHz Band High Gain Mode)

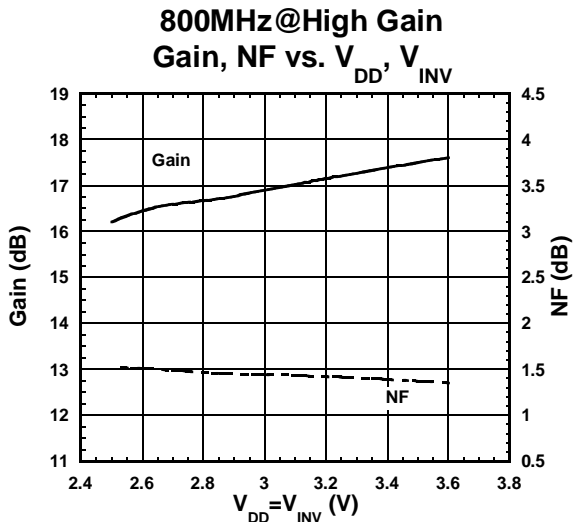

Condition
 $T_a = +25^\circ\text{C}$,
 $f = 885\text{MHz}$,
 $V_{CTL1} = 1.85\text{V}$, $V_{CTL2} = 0\text{V}$, $V_{CTL3} = 1.85\text{V}$

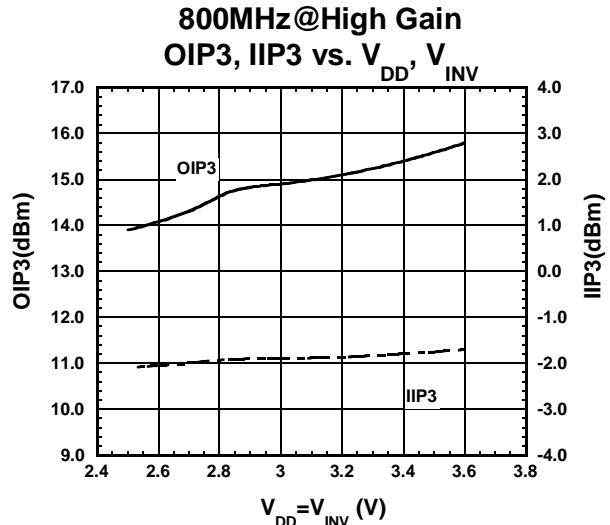

Condition
 $T_a = +25^\circ\text{C}$,
 $f_1 = 885\text{MHz}$, $f_2 = f_1 + 100\text{kHz}$,
 $P_{in} = -30\text{dBm}$,
 $V_{CTL1} = 1.85\text{V}$, $V_{CTL2} = 0\text{V}$, $V_{CTL3} = 1.85\text{V}$

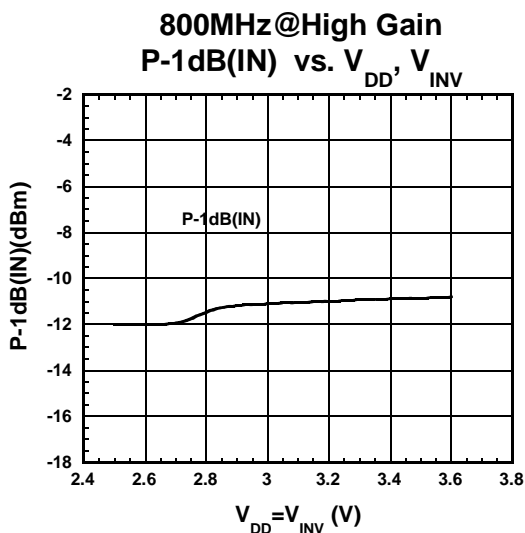

Condition
 $T_a = +25^\circ\text{C}$,
 $f = 885\text{MHz}$,
 $V_{CTL1} = 1.85\text{V}$, $V_{CTL2} = 0\text{V}$, $V_{CTL3} = 1.85\text{V}$

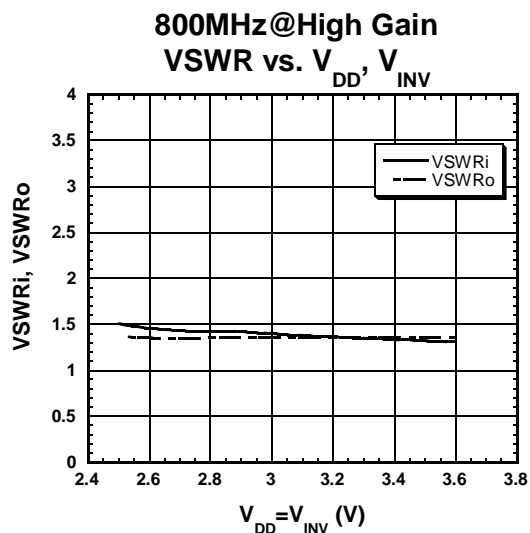

Condition
 $T_a = +25^\circ\text{C}$,
 $f = 885\text{MHz}$,
 $V_{CTL1} = 1.85\text{V}$, $V_{CTL2} = 0\text{V}$, $V_{CTL3} = 1.85\text{V}$

■ ELECTRICAL CHARACTERISTICS (800MHz Band High Gain Mode)

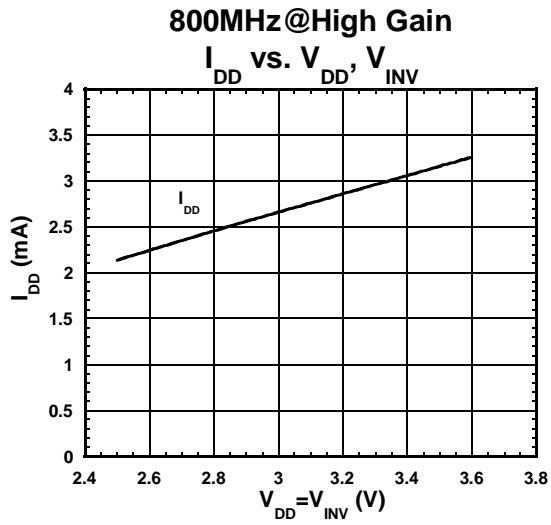

Condition

$T_a = +25^\circ\text{C}$,

RF=OFF

$V_{CTL1} = 1.85\text{V}$, $V_{CTL2} = 0\text{V}$, $V_{CTL3} = 1.85\text{V}$

NJG1125PB5

■ ELECTRICAL CHARACTERISTICS (800MHz Band High Gain Mode)

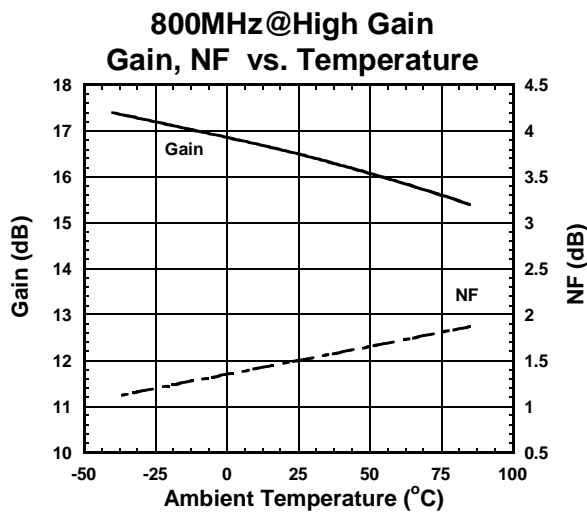

Condition
 $f=885\text{MHz}$,
 $V_{DD}=V_{INV}=2.7\text{V}$,
 $V_{CTL1}=1.85\text{V}$, $V_{CTL2}=0\text{V}$, $V_{CTL3}=1.85\text{V}$

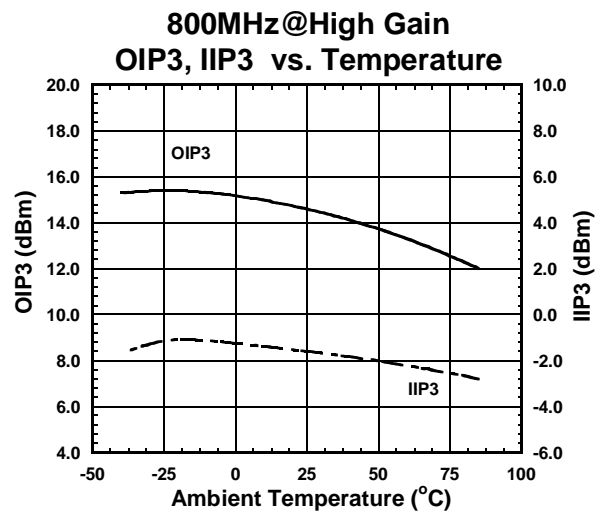

Condition
 $f1=885\text{MHz}$, $f2=f1+100\text{kHz}$,
 $\text{Pin}=-30\text{dBm}$,
 $V_{DD}=V_{INV}=2.7\text{V}$,
 $V_{CTL1}=1.85\text{V}$, $V_{CTL2}=0\text{V}$, $V_{CTL3}=1.85\text{V}$

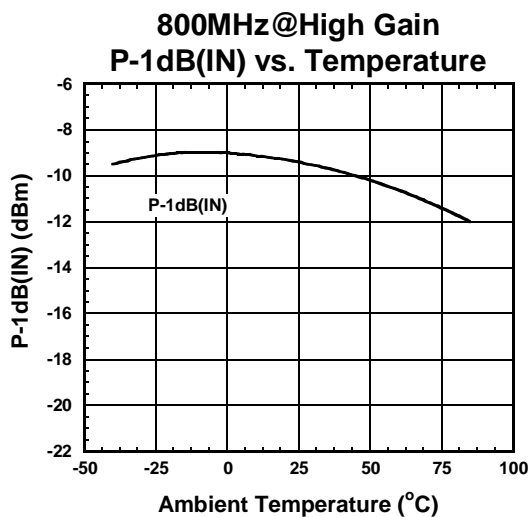

Condition
 $f=885\text{MHz}$,
 $V_{DD}=V_{INV}=2.7\text{V}$,
 $V_{CTL1}=1.85\text{V}$, $V_{CTL2}=0\text{V}$, $V_{CTL3}=1.85\text{V}$

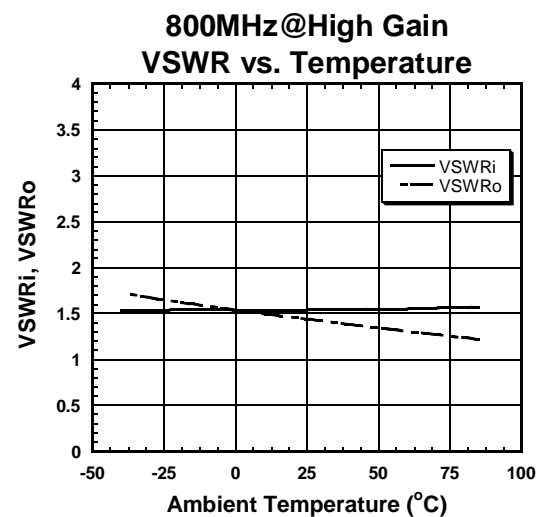

Condition
 $f=885\text{MHz}$,
 $V_{DD}=V_{INV}=2.7\text{V}$,
 $V_{CTL1}=1.85\text{V}$, $V_{CTL2}=0\text{V}$, $V_{CTL3}=1.85\text{V}$

■ ELECTRICAL CHARACTERISTICS (800MHz Band High Gain Mode)

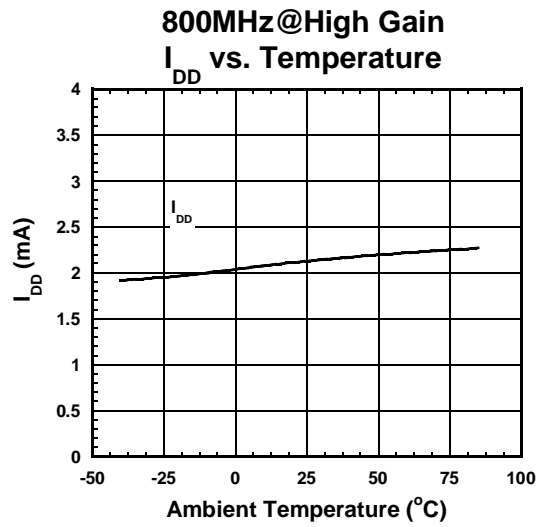

Condition

RF=OFF

$V_{DD} = V_{INV} = 2.7V$,

$V_{CTL1} = 1.85V$, $V_{CTL2} = 0V$, $V_{CTL3} = 1.85V$

NJG1125PB5

ELECTRICAL CHARACTERISTICS (800MHz Band Low Gain Mode)

Condition: $T_a=+25^{\circ}\text{C}$, $V_{DD}=V_{INV}=2.7\text{V}$, $V_{CTL1}=1.85\text{V}$, $V_{CTL2}=0\text{V}$, $V_{CTL3}=1.85\text{V}$

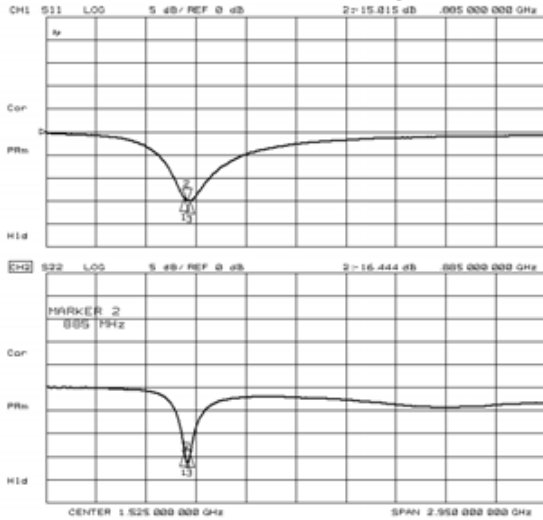

S11, S22

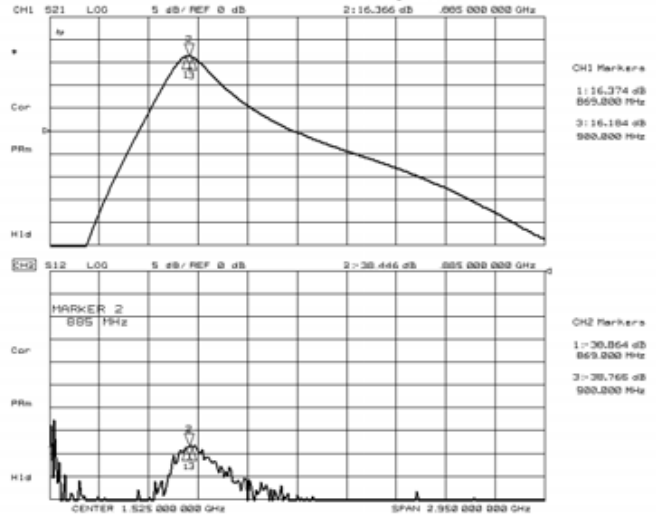

S21, S12

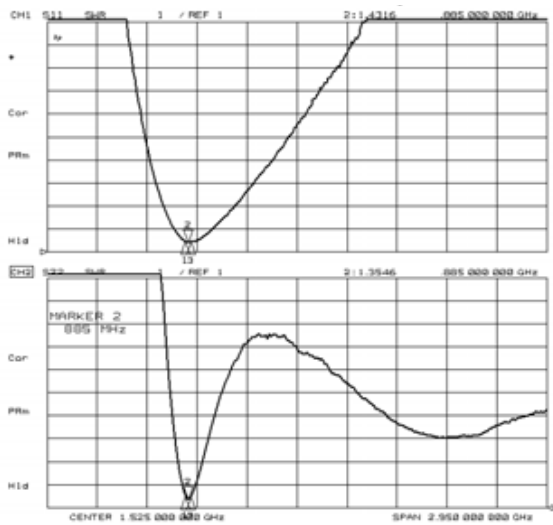

VSWR

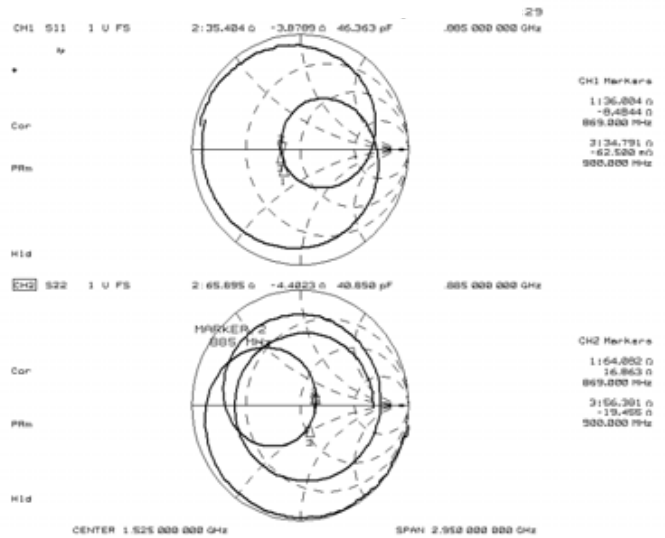

Zin, Zout

■ ELECTRICAL CHARACTERISTICS (800MHz Band Low Gain Mode)

Condition: $T_a=+25^{\circ}\text{C}$, $V_{DD}=V_{INV}=2.7\text{V}$, $V_{CTL1}=1.85\text{V}$, $V_{CTL2}=0\text{V}$, $V_{CTL3}=1.85\text{V}$

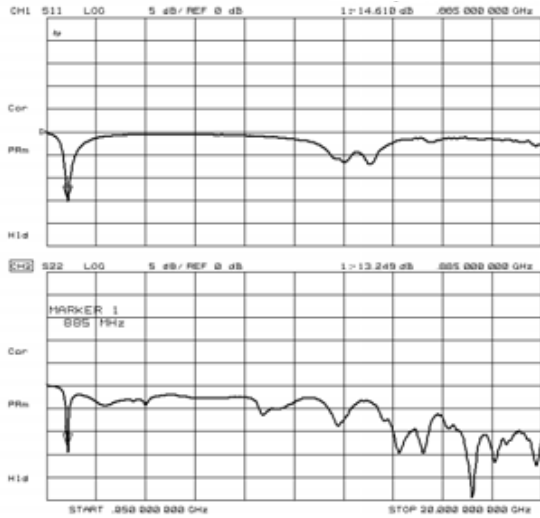

S11, S22
(f=50MHz~20GHz)

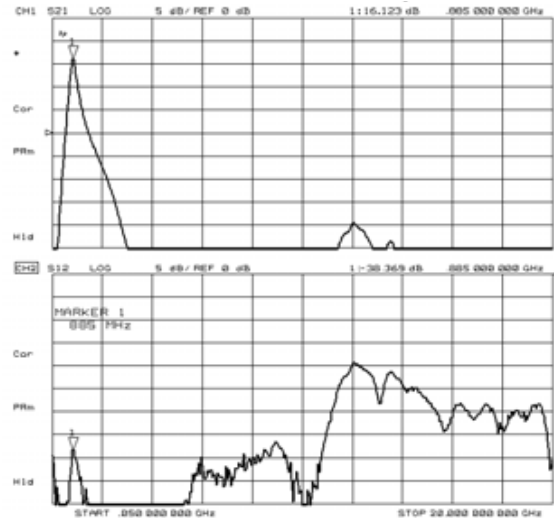

S21, S12
(f=50MHz~20GHz)

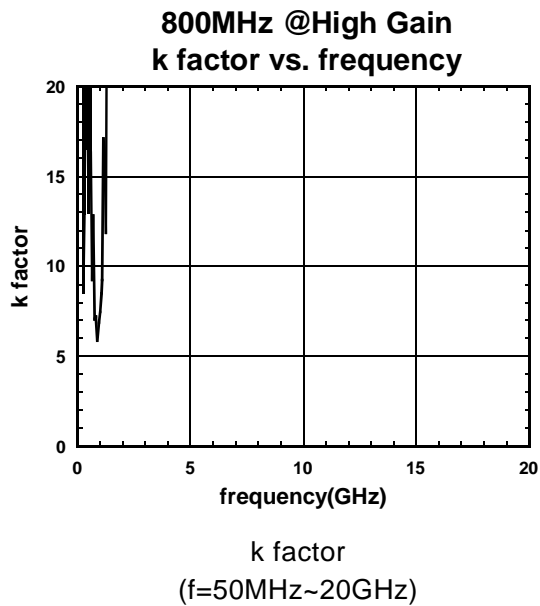

NJG1125PB5

■ ELECTRICAL CHARACTERISTICS (800MHz Band Low Gain Mode)

**800MHz@Low Gain
Pout vs. Pin**

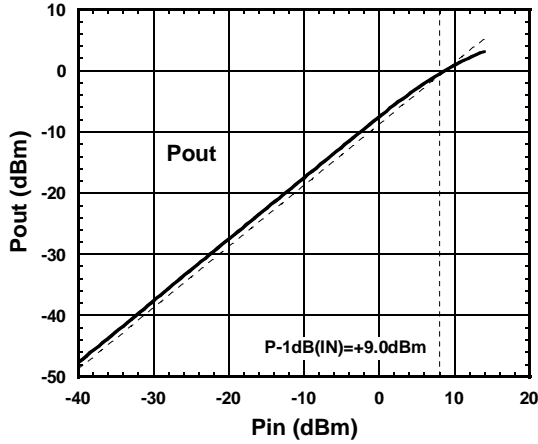

Condition
 $T_a = +25^\circ\text{C}$,
 $f = 885\text{MHz}$,
 $V_{DD} = V_{INV} = 2.7\text{V}$,
 $V_{CTL1} = 1.85\text{V}$, $V_{CTL2} = 0\text{V}$, $V_{CTL3} = 0\text{V}$

**800MHz@Low Gain
Gain, IDD vs. Pin**

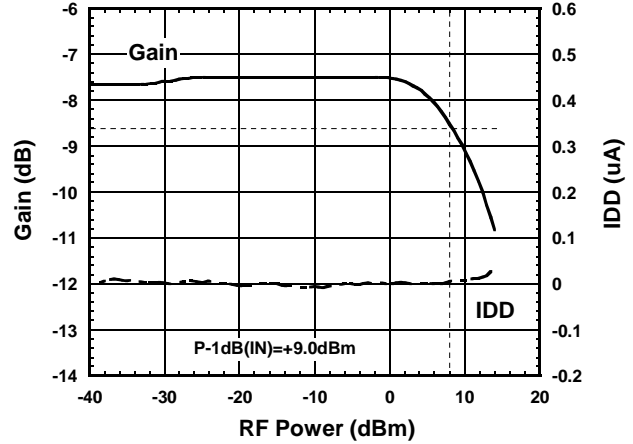

Condition
 $T_a = +25^\circ\text{C}$,
 $f = 885\text{MHz}$,
 $V_{DD} = V_{INV} = 2.7\text{V}$,
 $V_{CTL1} = 1.85\text{V}$, $V_{CTL2} = 0\text{V}$, $V_{CTL3} = 0\text{V}$

**800MHz@Low Gain
NF vs. frequency**

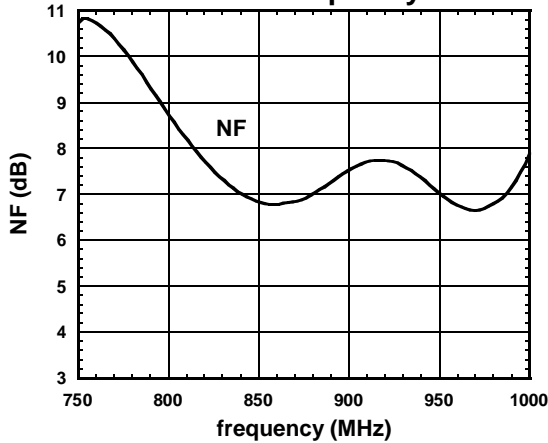

Condition
 $T_a = +25^\circ\text{C}$,
 $f = 750\sim 1\text{GHz}$,
 $V_{DD} = V_{INV} = 2.7\text{V}$,
 $V_{CTL1} = 1.85\text{V}$, $V_{CTL2} = 0\text{V}$, $V_{CTL3} = 0\text{V}$

**800MHz@Low Gain
Pout, IM3 vs. Pin**

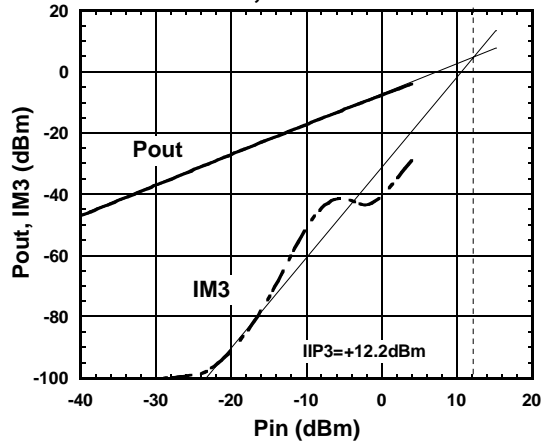

Condition
 $T_a = +25^\circ\text{C}$,
 $f_1 = 885\text{MHz}$, $f_2 = f_1 + 100\text{kHz}$,
 $V_{DD} = V_{INV} = 2.7\text{V}$,
 $V_{CTL1} = 1.85\text{V}$, $V_{CTL2} = 0\text{V}$, $V_{CTL3} = 0\text{V}$

■ ELECTRICAL CHARACTERISTICS (800MHz Band Low Gain Mode)

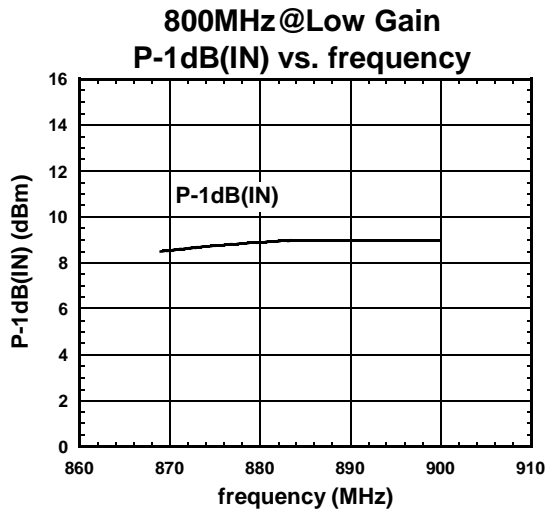

Condition

$T_a = +25^\circ\text{C}$,
 $f = 869 \sim 900\text{MHz}$,
 $V_{DD} = V_{INV} = 2.7\text{V}$,
 $V_{CTL1} = 1.85\text{V}$, $V_{CTL2} = 0\text{V}$, $V_{CTL3} = 0\text{V}$

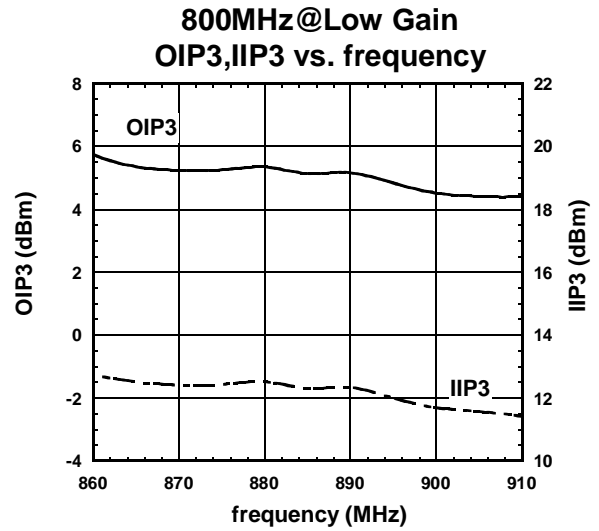

Condition

$T_a = +25^\circ\text{C}$,
 $f_1 = 860 \sim 910\text{MHz}$, $f_2 = f_1 + 100\text{kHz}$,
 $\text{Pin} = -20\text{dBm}$,
 $V_{DD} = V_{INV} = 2.7\text{V}$,
 $V_{CTL1} = 1.85\text{V}$, $V_{CTL2} = 0\text{V}$, $V_{CTL3} = 0\text{V}$

NJG1125PB5

ELECTRICAL CHARACTERISTICS (800MHz Band Low Gain Mode)

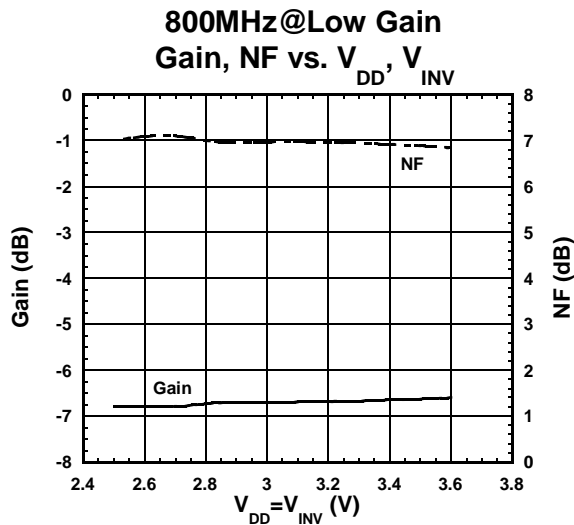

Condition
 $T_a = +25^\circ\text{C}$,
 $f = 885\text{MHz}$,
 $V_{CTL1} = 1.85\text{V}$, $V_{CTL2} = 0\text{V}$, $V_{CTL3} = 0\text{V}$

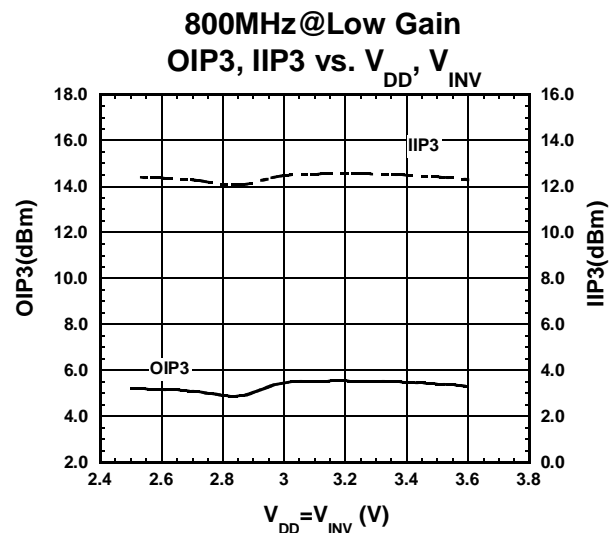

Condition
 $T_a = +25^\circ\text{C}$,
 $f_1 = 885\text{MHz}$, $f_2 = f_1 + 100\text{kHz}$,
 $P_{in} = -20\text{dBm}$,
 $V_{CTL1} = 1.85\text{V}$, $V_{CTL2} = 0\text{V}$, $V_{CTL3} = 0\text{V}$

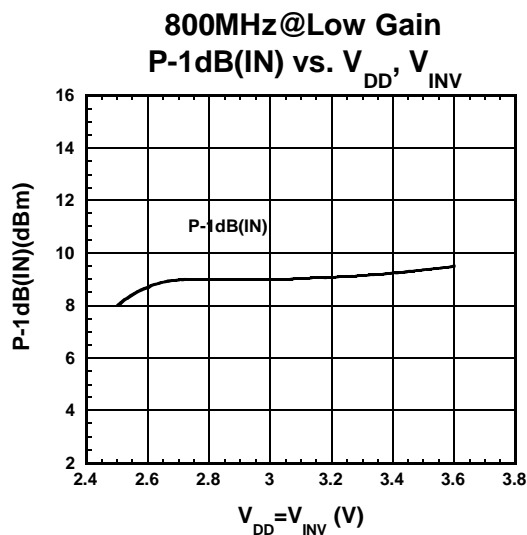

Condition
 $T_a = +25^\circ\text{C}$,
 $f = 885\text{MHz}$,
 $V_{CTL1} = 1.85\text{V}$, $V_{CTL2} = 0\text{V}$, $V_{CTL3} = 0\text{V}$

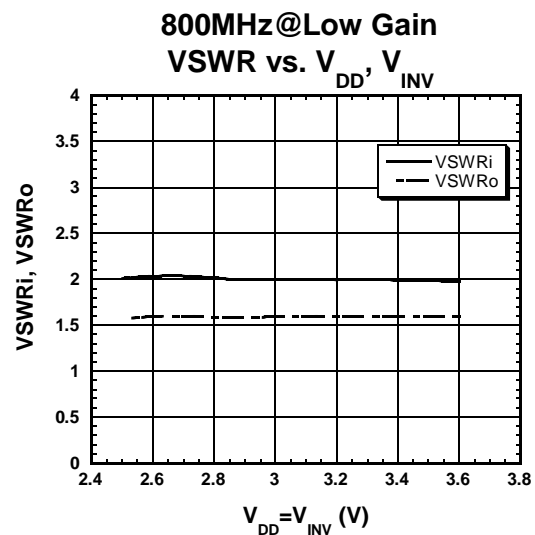

Condition
 $T_a = +25^\circ\text{C}$,
 $f = 885\text{MHz}$,
 $V_{CTL1} = 1.85\text{V}$, $V_{CTL2} = 0\text{V}$, $V_{CTL3} = 0\text{V}$

■ ELECTRICAL CHARACTERISTICS (800MHz Band Low Gain Mode)

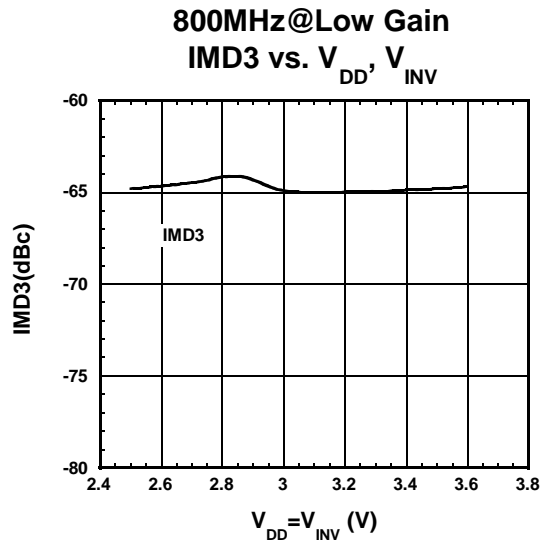

Condition

$T_a = +25^\circ\text{C}$,
 $f_1 = 885\text{MHz}$, $f_2 = f_1 + 100\text{kHz}$,
 $P_{in} = -20\text{dBm}$,
 $V_{CTL1} = 1.85\text{V}$, $V_{CTL2} = 0\text{V}$, $V_{CTL3} = 0\text{V}$

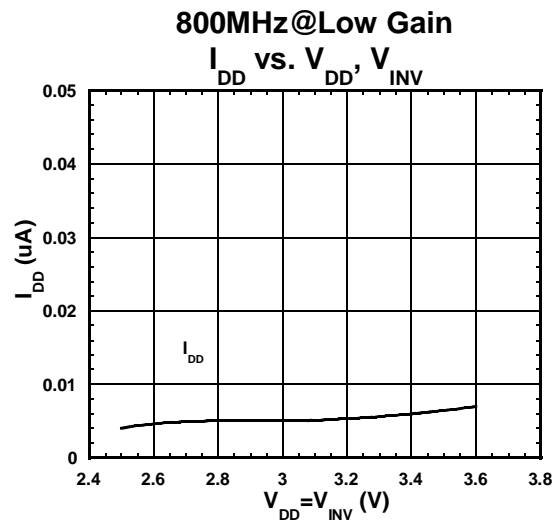

Condition

$T_a = +25^\circ\text{C}$,
 $\text{RF} = \text{OFF}$
 $V_{CTL1} = 1.85\text{V}$, $V_{CTL2} = 0\text{V}$, $V_{CTL3} = 0\text{V}$

NJG1125PB5

■ ELECTRICAL CHARACTERISTICS (800MHz Band Low Gain Mode)

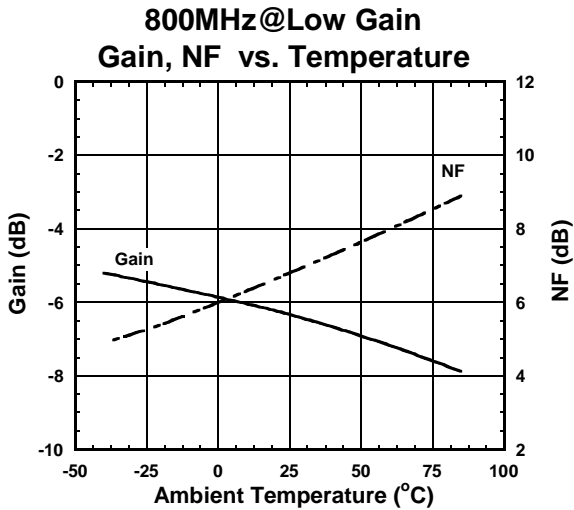

Condition

f=885MHz,
 $V_{DD} = V_{INV} = 2.7V$,
 $V_{CTL1} = 1.85V$, $V_{CTL2} = 0V$, $V_{CTL3} = 0V$

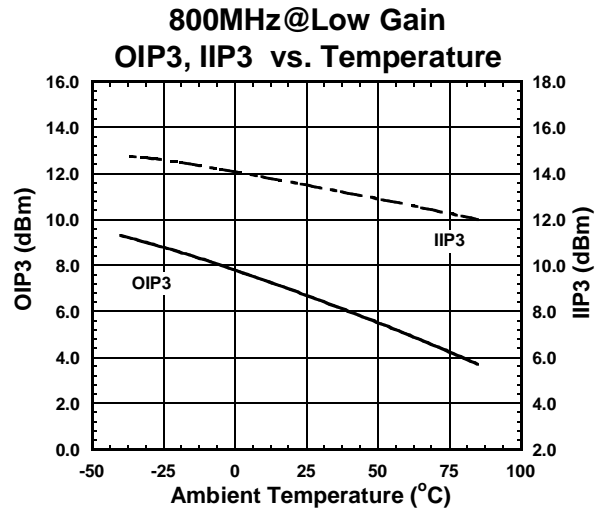

Condition

f1=885MHz, f2=f1+100kHz,
 $P_{in} = -20dBm$,
 $V_{DD} = V_{INV} = 2.7V$,
 $V_{CTL1} = 1.85V$, $V_{CTL2} = 0V$, $V_{CTL3} = 0V$

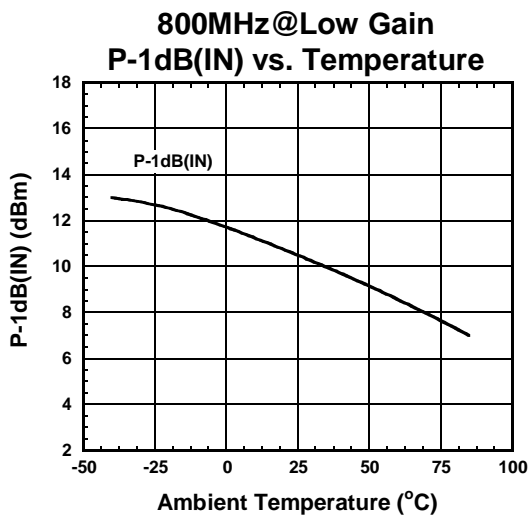

Condition

f=885MHz,
 $V_{DD} = V_{INV} = 2.7V$,
 $V_{CTL1} = 1.85V$, $V_{CTL2} = 0V$, $V_{CTL3} = 0V$

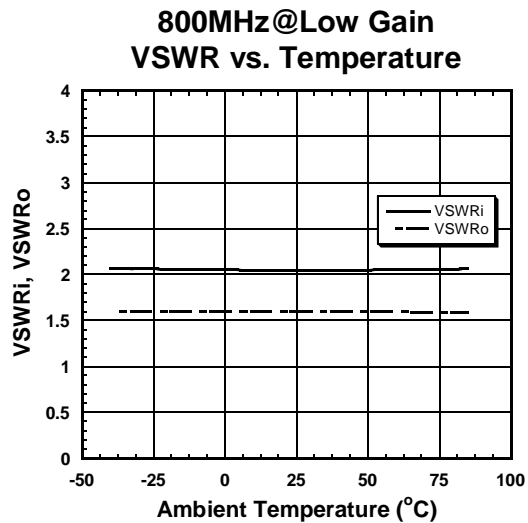

Condition

f=885MHz,
 $V_{DD} = V_{INV} = 2.7V$,
 $V_{CTL1} = 1.85V$, $V_{CTL2} = 0V$, $V_{CTL3} = 0V$

■ ELECTRICAL CHARACTERISTICS (800MHz Band Low Gain Mode)

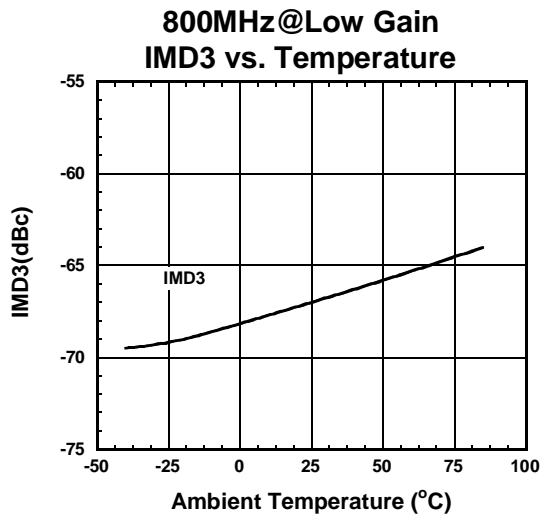

Condition

$f_1=885\text{MHz}$, $f_2=f_1+100\text{kHz}$,
 $P_{in}=-20\text{dBm}$,
 $V_{DD}=V_{INV}=2.7\text{V}$,
 $V_{CTL1}=1.85\text{V}$, $V_{CTL2}=0\text{V}$, $V_{CTL3}=0\text{V}$

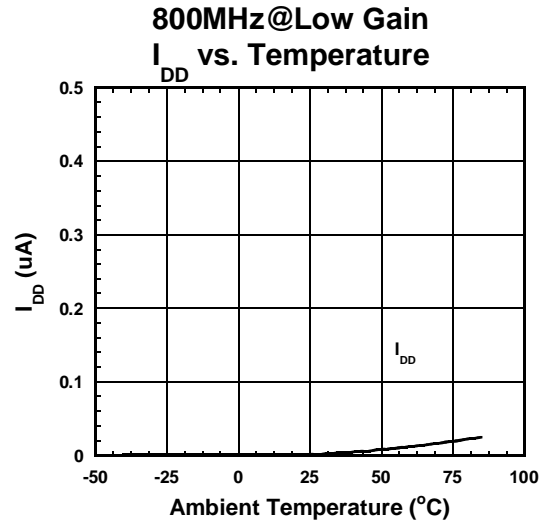

Condition

RF=OFF
 $V_{DD}=V_{INV}=2.7\text{V}$,
 $V_{CTL1}=1.85\text{V}$, $V_{CTL2}=0\text{V}$, $V_{CTL3}=0\text{V}$

NJG1125PB5

ELECTRICAL CHARACTERISTICS (800MHz Band Low Gain Mode)

Condition: $T_a=+25^{\circ}\text{C}$, $V_{DD}=V_{INV}=2.7\text{V}$, $V_{CTL1}=1.85\text{V}$, $V_{CTL2}=0\text{V}$, $V_{CTL3}=0\text{V}$

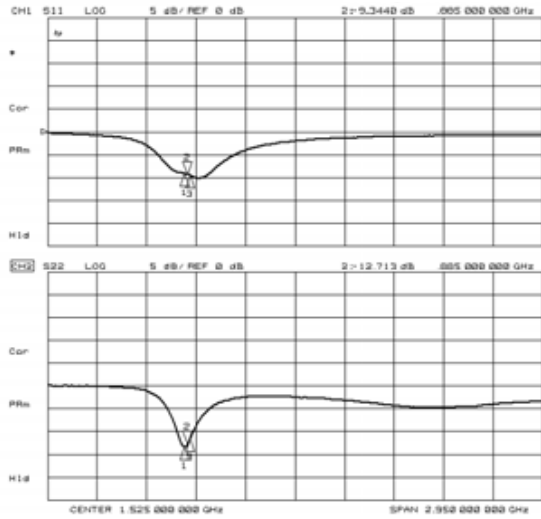

S11, S22

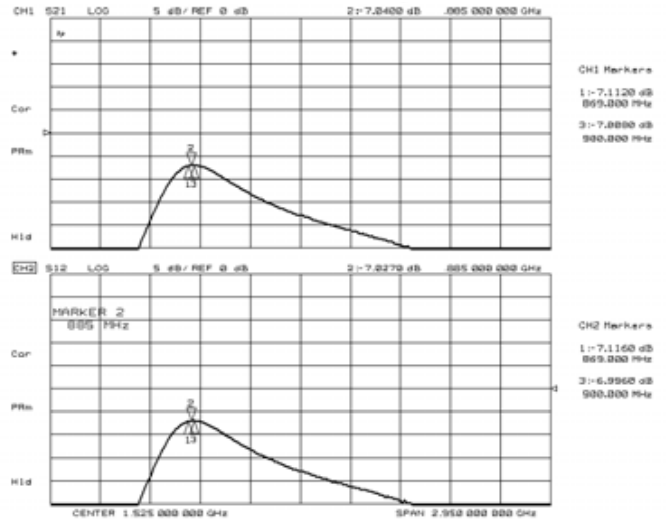

S21, S12

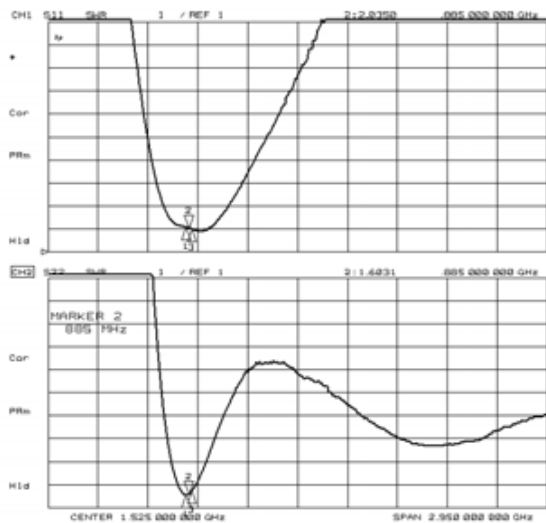

VSWR

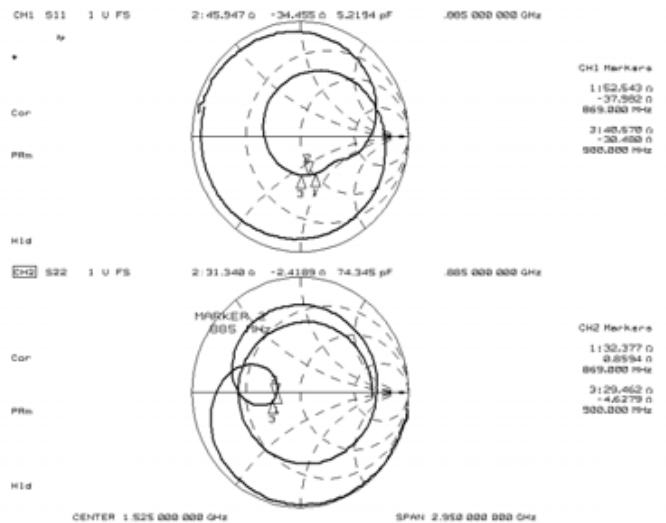

Zin, Zout

ELECTRICAL CHARACTERISTICS (800MHz Band Low Gain Mode)

Condition: $T_a=+25^{\circ}\text{C}$, $V_{DD}=V_{INV}=2.7\text{V}$, $V_{CTL1}=1.85\text{V}$, $V_{CTL2}=0\text{V}$, $V_{CTL3}=0\text{V}$

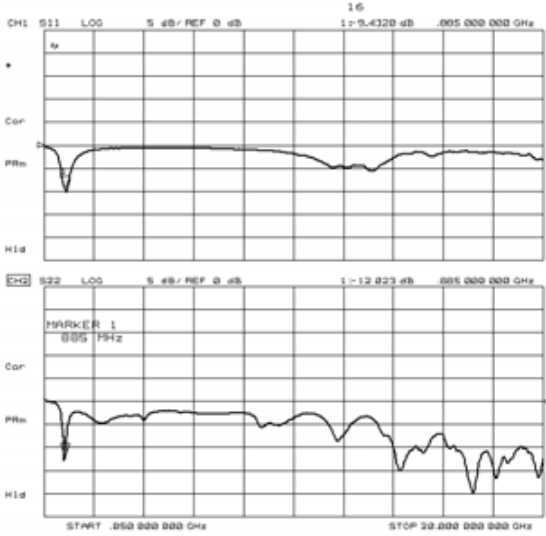

S11, S22
(f=50MHz~20GHz)

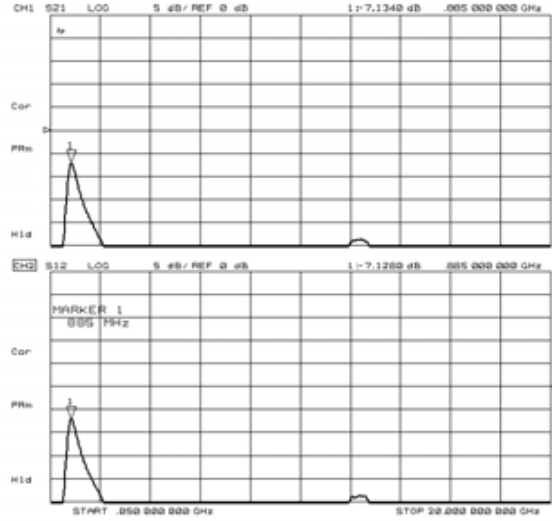

S21, S12
(f=50MHz~20GHz)

800MHz @Low Gain k factor vs. frequency

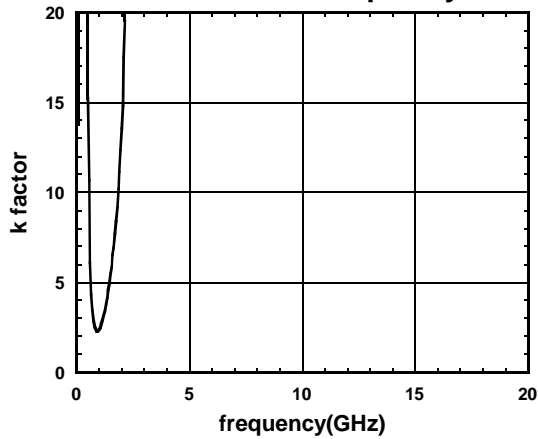

k factor
(f=50MHz~20GHz)

NJG1125PB5

ELECTRICAL CHARACTERISTICS (1.7GHz Band High Gain Mode)

1.7GHz@High Gain
Pout vs. Pin

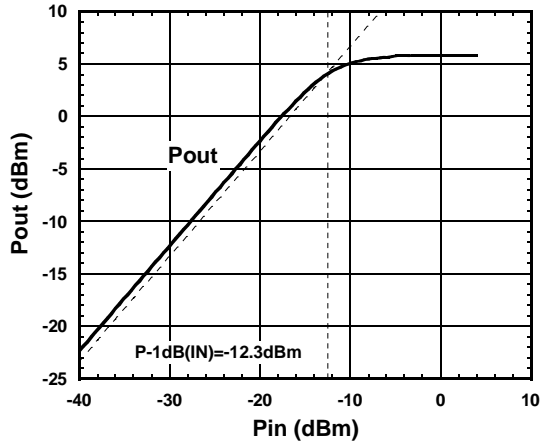

Condition

$T_a = +25^\circ\text{C}$,
 $f = 1860\text{MHz}$,
 $V_{DD} = V_{INV} = 2.7\text{V}$,
 $V_{CTL1} = 0\text{V}$, $V_{CTL2} = 1.85\text{V}$, $V_{CTL3} = 1.85\text{V}$

1.7GHz@High Gain
Gain, IDD vs. Pin

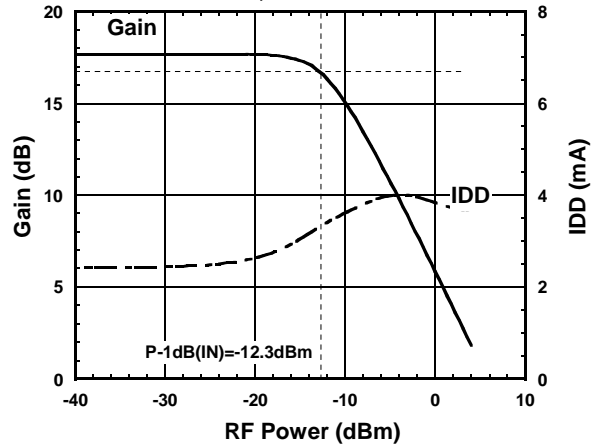

Condition

$T_a = +25^\circ\text{C}$,
 $f = 1860\text{MHz}$,
 $V_{DD} = V_{INV} = 2.7\text{V}$,
 $V_{CTL1} = 0\text{V}$, $V_{CTL2} = 1.85\text{V}$, $V_{CTL3} = 1.85\text{V}$

1.7GHz@High Gain
NF vs. frequency

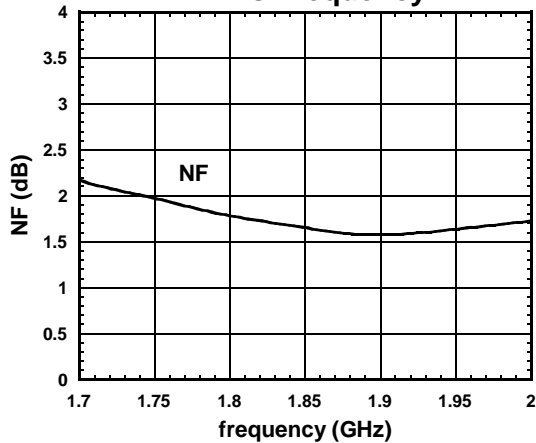

Condition

$T_a = +25^\circ\text{C}$,
 $f = 1.7\sim 2\text{GHz}$,
 $V_{DD} = V_{INV} = 2.7\text{V}$,
 $V_{CTL1} = 0\text{V}$, $V_{CTL2} = 1.85\text{V}$, $V_{CTL3} = 1.85\text{V}$

1.7GHz@High Gain
Pout, IM3 vs. Pin

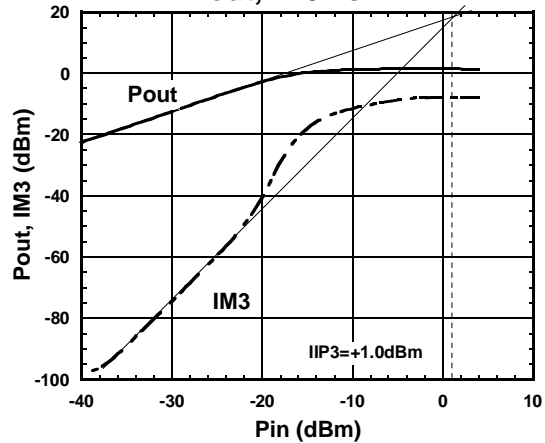

Condition

$T_a = +25^\circ\text{C}$,
 $f_1 = 1860\text{MHz}$, $f_2 = f_1 + 100\text{kHz}$,
 $V_{DD} = V_{INV} = 2.7\text{V}$,
 $V_{CTL1} = 0\text{V}$, $V_{CTL2} = 1.85\text{V}$, $V_{CTL3} = 1.85\text{V}$

■ ELECTRICAL CHARACTERISTICS (1.7GHz Band High Gain Mode)

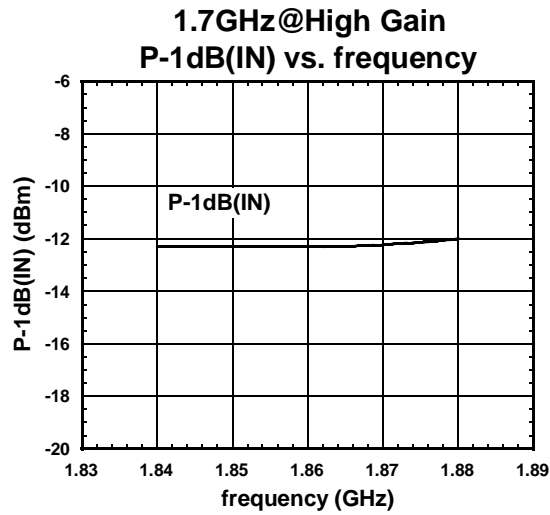

Condition

$T_a = +25^\circ\text{C}$,
 $f = 1.84 \sim 1.88\text{GHz}$,
 $V_{DD} = V_{INV} = 2.7\text{V}$,
 $V_{CTL1} = 0\text{V}$, $V_{CTL2} = 1.85\text{V}$, $V_{CTL3} = 1.85\text{V}$

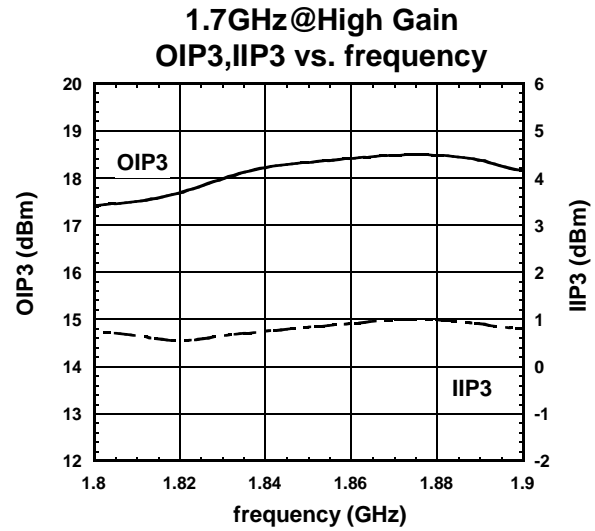

Condition

$T_a = +25^\circ\text{C}$,
 $f_1 = 1.8 \sim 1.90\text{GHz}$, $f_2 = f_1 + 100\text{kHz}$,
 $\text{Pin} = -30\text{dBm}$,
 $V_{DD} = V_{INV} = 2.7\text{V}$,
 $V_{CTL1} = 0\text{V}$, $V_{CTL2} = 1.85\text{V}$, $V_{CTL3} = 1.85\text{V}$

NJG1125PB5

ELECTRICAL CHARACTERISTICS (1.7GHz Band High Gain Mode)

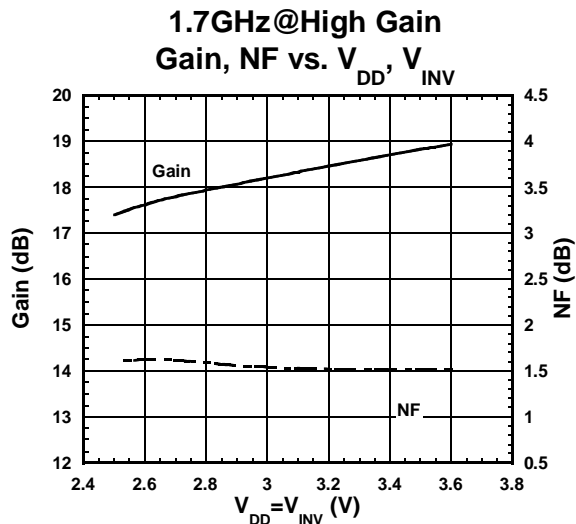

Condition

$T_a = +25^\circ\text{C}$,
 $f = 1860\text{MHz}$,
 $V_{CTL1} = 0\text{V}$, $V_{CTL2} = 1.85\text{V}$, $V_{CTL3} = 1.85\text{V}$

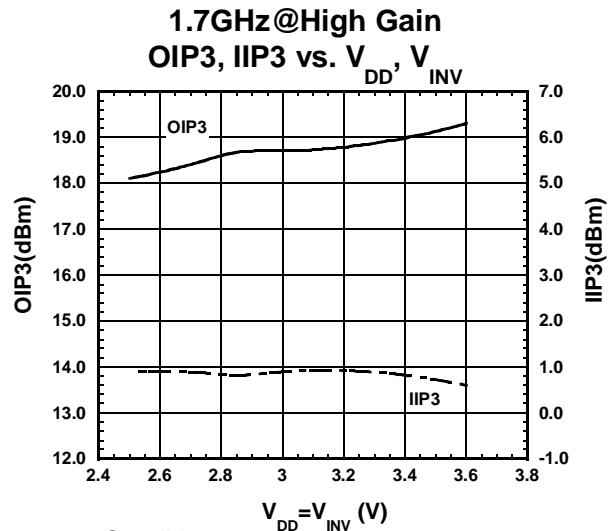

Condition

$T_a = +25^\circ\text{C}$,
 $f_1 = 1860\text{MHz}$, $f_2 = f_1 + 100\text{kHz}$,
 $P_{in} = -30\text{dBm}$,
 $V_{CTL1} = 0\text{V}$, $V_{CTL2} = 1.85\text{V}$, $V_{CTL3} = 1.85\text{V}$

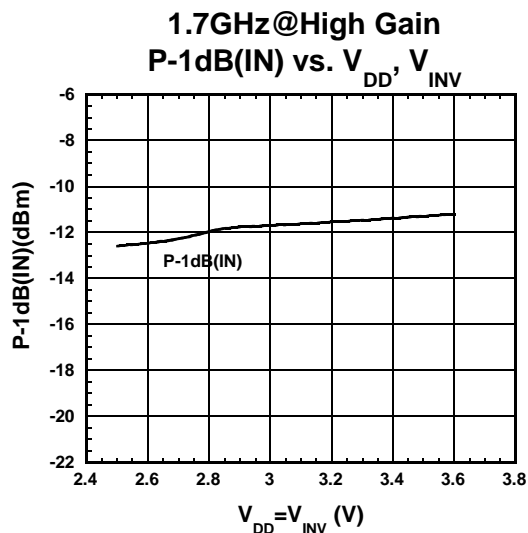

Condition

$T_a = +25^\circ\text{C}$,
 $f = 1860\text{MHz}$,
 $V_{CTL1} = 0\text{V}$, $V_{CTL2} = 1.85\text{V}$, $V_{CTL3} = 1.85\text{V}$

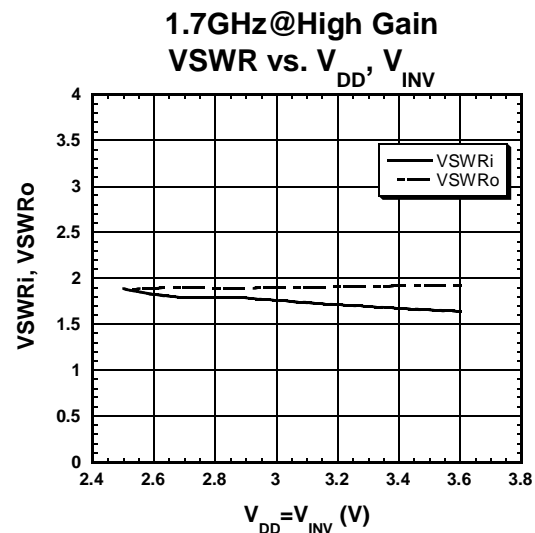

Condition

$T_a = +25^\circ\text{C}$,
 $f = 1860\text{MHz}$,
 $V_{CTL1} = 0\text{V}$, $V_{CTL2} = 1.85\text{V}$, $V_{CTL3} = 1.85\text{V}$

■ ELECTRICAL CHARACTERISTICS (1.7GHz Band High Gain Mode)

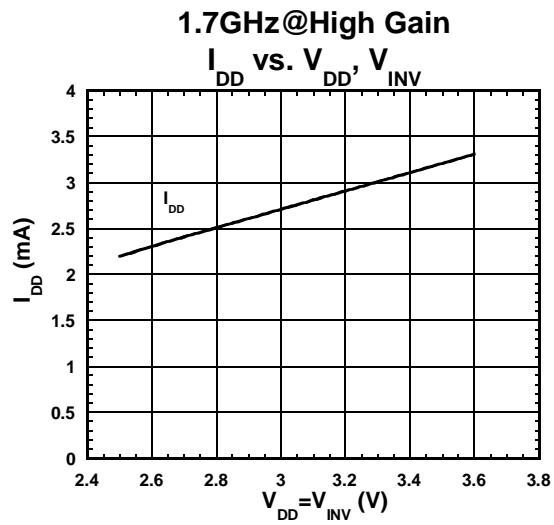

Condition

$T_a = +25^\circ\text{C}$,

RF=OFF

$V_{CTL1} = 0\text{V}$, $V_{CTL2} = 1.85\text{V}$, $V_{CTL3} = 1.85\text{V}$

NJG1125PB5

ELECTRICAL CHARACTERISTICS (1.7GHz Band High Gain Mode)

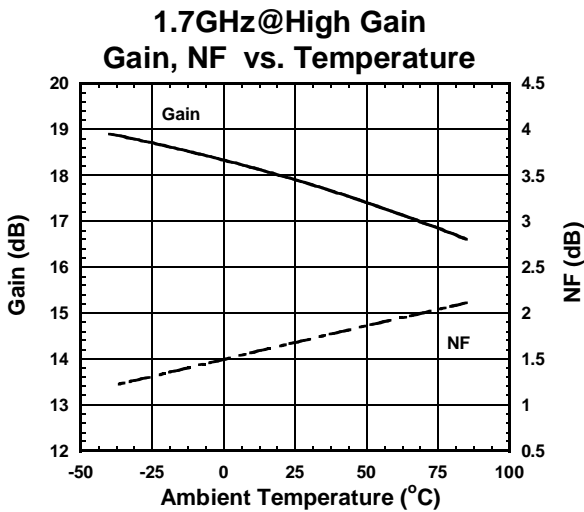

Condition

$f=1860\text{MHz}$,
 $V_{DD}=V_{INV}=2.7\text{V}$,
 $V_{CTL1}=0\text{V}$, $V_{CTL2}=1.85\text{V}$, $V_{CTL3}=1.85\text{V}$

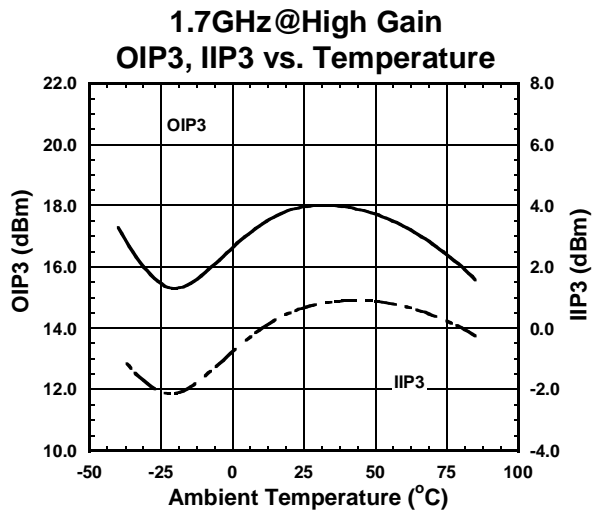

Condition

$f_1=1860\text{MHz}$, $f_2=f_1+100\text{kHz}$,
 $\text{Pin}=-30\text{dBm}$,
 $V_{DD}=V_{INV}=2.7\text{V}$,
 $V_{CTL1}=0\text{V}$, $V_{CTL2}=1.85\text{V}$, $V_{CTL3}=1.85\text{V}$

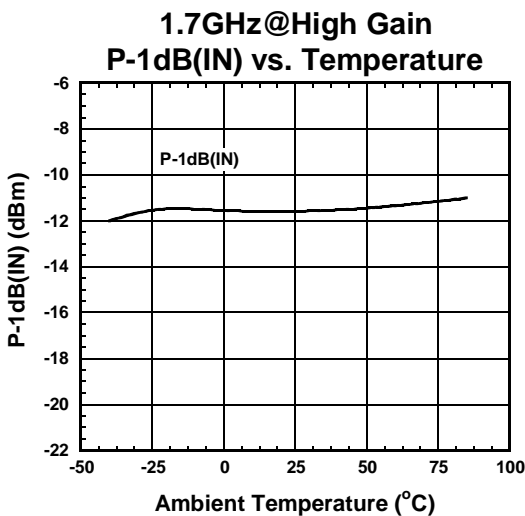

Condition

$f=1860\text{MHz}$,
 $V_{DD}=V_{INV}=2.7\text{V}$,
 $V_{CTL1}=0\text{V}$, $V_{CTL2}=1.85\text{V}$, $V_{CTL3}=1.85\text{V}$

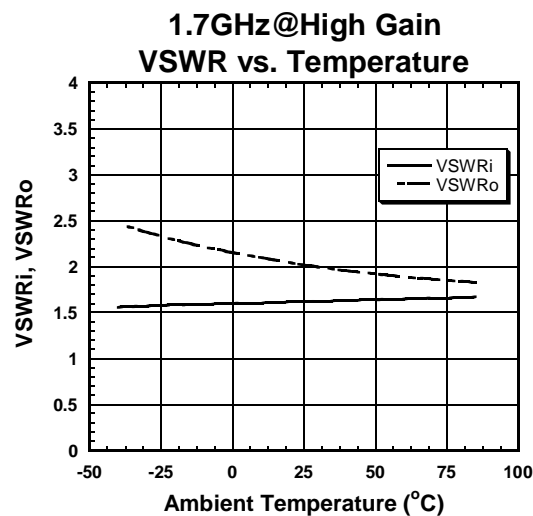

Condition

$f=1860\text{MHz}$,
 $V_{DD}=V_{INV}=2.7\text{V}$,
 $V_{CTL1}=0\text{V}$, $V_{CTL2}=1.85\text{V}$, $V_{CTL3}=1.85\text{V}$

■ ELECTRICAL CHARACTERISTICS (1.7GHz Band High Gain Mode)

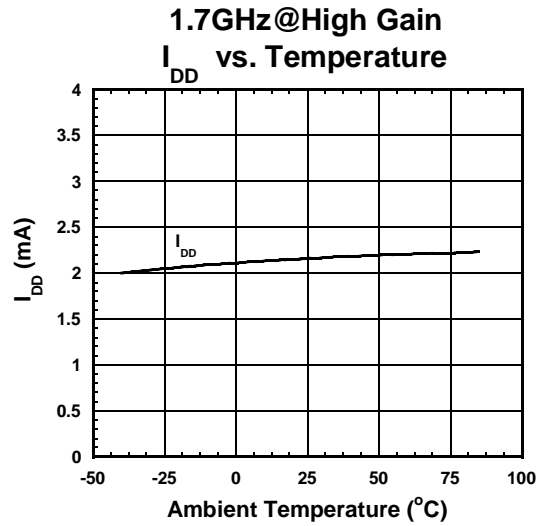

Condition

RF=OFF

$V_{DD} = V_{INV} = 2.7V$,

$V_{CTL1} = 0V$, $V_{CTL2} = 1.85V$, $V_{CTL3} = 1.85V$

NJG1125PB5

ELECTRICAL CHARACTERISTICS (1.7GHz Band High Gain Mode)

Condition: $T_a=+25^{\circ}\text{C}$, $V_{DD}=V_{INV}=2.7\text{V}$, $V_{CTL1}=0\text{V}$, $V_{CTL2}=1.85\text{V}$, $V_{CTL3}=1.85\text{V}$

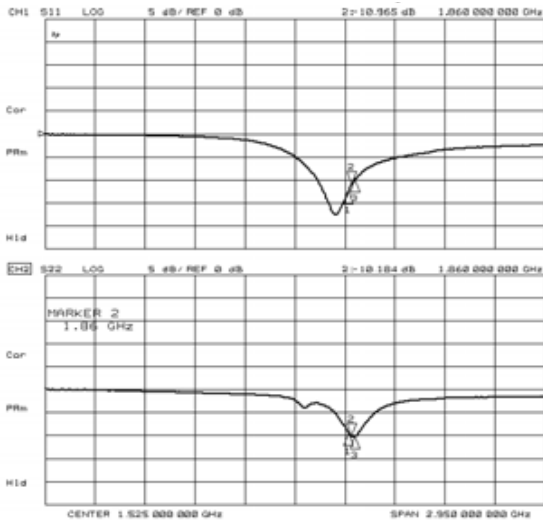

S11, S22

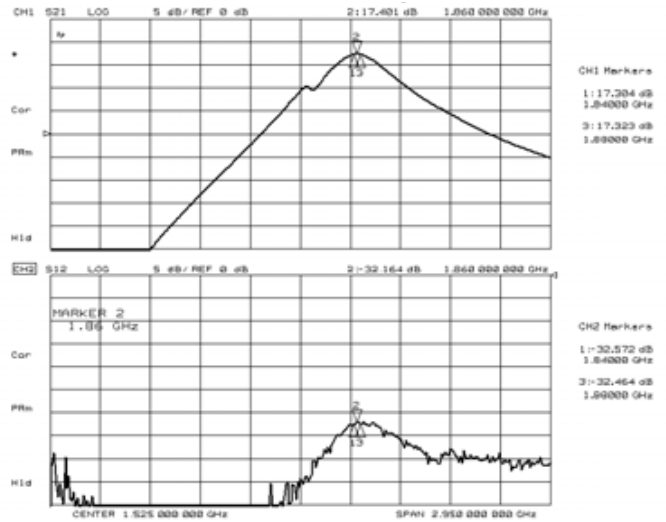

S21, S12

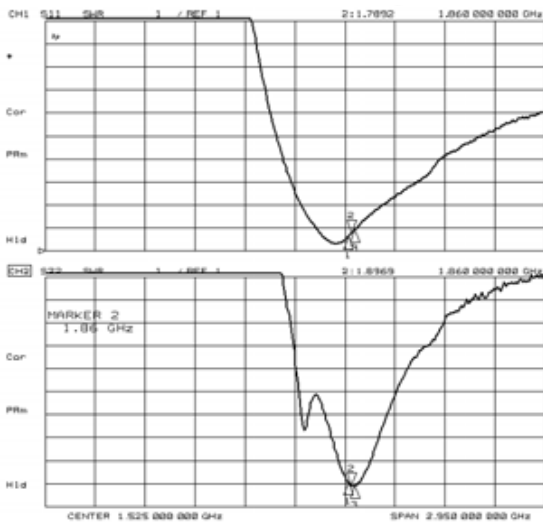

VSWR

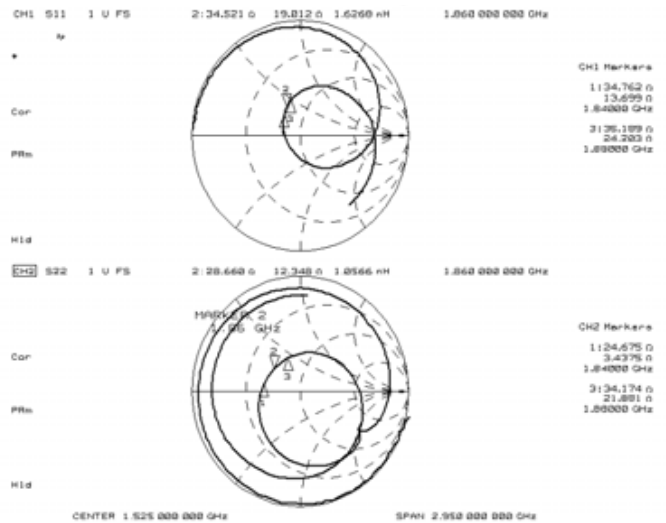

Zin, Zout

ELECTRICAL CHARACTERISTICS (1.7GHz Band High Gain Mode)

Condition: $T_a=+25^{\circ}\text{C}$, $V_{DD}=V_{INV}=2.7\text{V}$, $V_{CTL1}=0\text{V}$, $V_{CTL2}=1.85\text{V}$, $V_{CTL3}=1.85\text{V}$

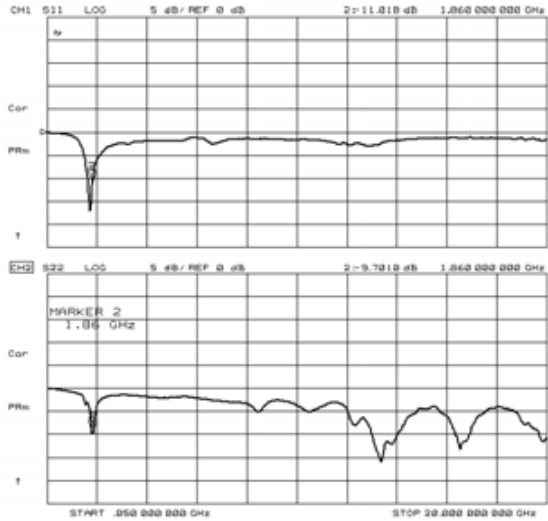

S11, S22
(f=50MHz~20GHz)

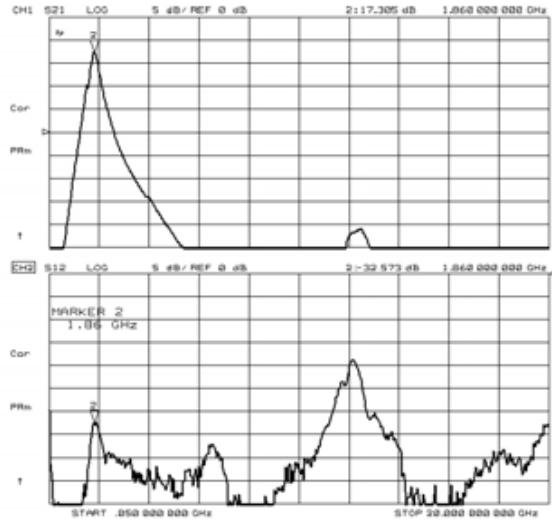

S21, S12
(f=50MHz~20GHz)

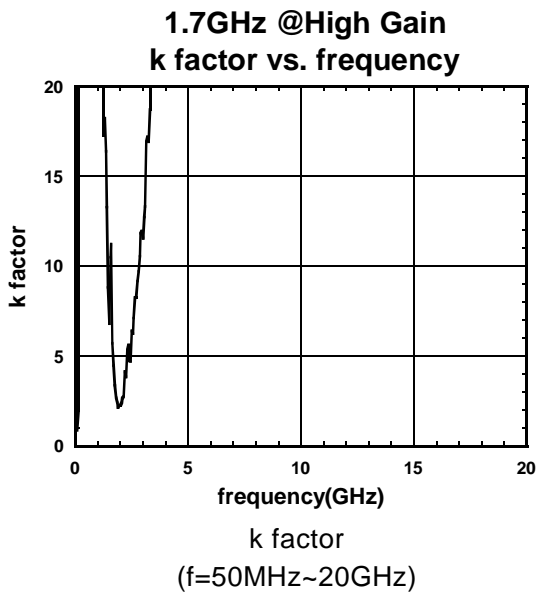

NJG1125PB5

ELECTRICAL CHARACTERISTICS (1.7GHz Band Low Gain Mode)

1.7GHz@Low Gain
Pout vs. Pin

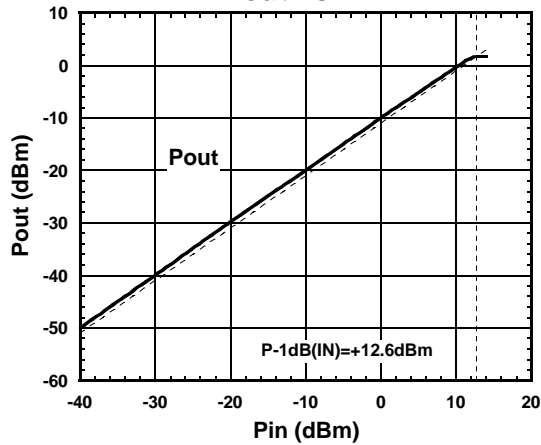

Condition

$T_a = +25^\circ\text{C}$,
 $f = 1860\text{MHz}$,
 $V_{DD} = V_{INV} = 2.7\text{V}$,
 $V_{CTL1} = 0\text{V}$, $V_{CTL2} = 1.85\text{V}$, $V_{CTL3} = 0\text{V}$

1.7GHz@Low Gain
Gain, IDD vs. Pin

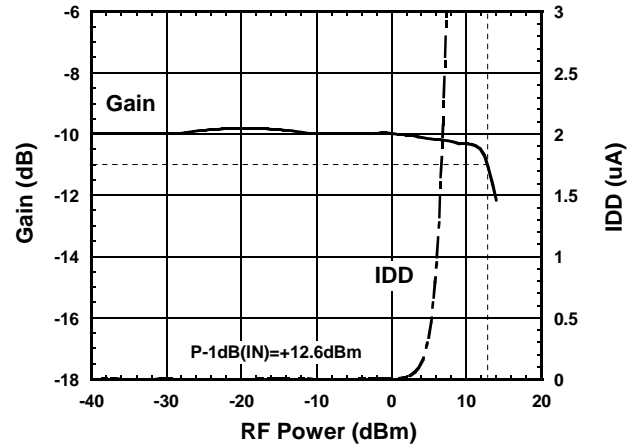

Condition

$T_a = +25^\circ\text{C}$,
 $f = 1860\text{MHz}$,
 $V_{DD} = V_{INV} = 2.7\text{V}$,
 $V_{CTL1} = 0\text{V}$, $V_{CTL2} = 1.85\text{V}$, $V_{CTL3} = 0\text{V}$

1.7GHz@Low Gain
NF vs. frequency

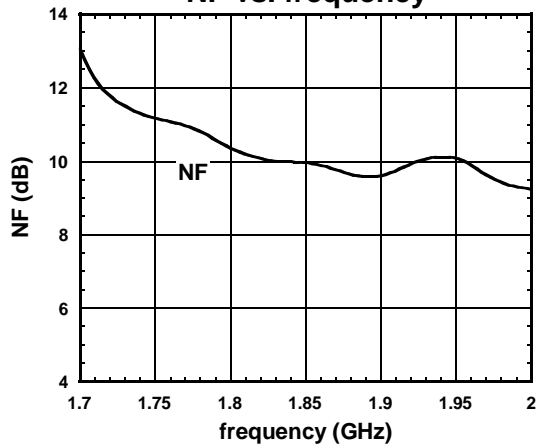

Condition

$T_a = +25^\circ\text{C}$,
 $f = 1.7 \sim 2.0\text{GHz}$,
 $V_{DD} = V_{INV} = 2.7\text{V}$,
 $V_{CTL1} = 0\text{V}$, $V_{CTL2} = 1.85\text{V}$, $V_{CTL3} = 0\text{V}$

1.7GHz@Low Gain
Pout, IM3 vs. Pin

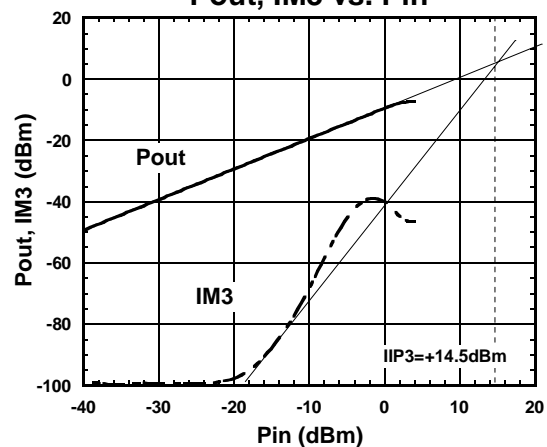

Condition

$T_a = +25^\circ\text{C}$,
 $f_1 = 1860\text{MHz}$, $f_2 = f_1 + 100\text{kHz}$,
 $V_{DD} = V_{INV} = 2.7\text{V}$,
 $V_{CTL1} = 0\text{V}$, $V_{CTL2} = 1.85\text{V}$, $V_{CTL3} = 0\text{V}$

■ ELECTRICAL CHARACTERISTICS (1.7GHz Band Low Gain Mode)

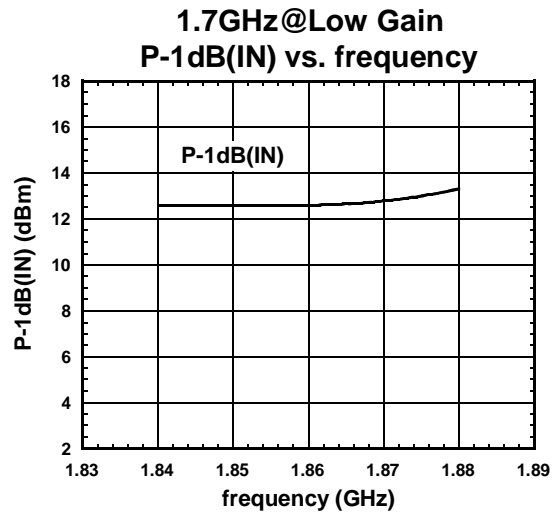

Condition

$T_a = +25^\circ\text{C}$,
 $f = 1.84 \sim 1.88\text{GHz}$,
 $V_{DD} = V_{INV} = 2.7\text{V}$,
 $V_{CTL1} = 0\text{V}$, $V_{CTL2} = 1.85\text{V}$, $V_{CTL3} = 0\text{V}$

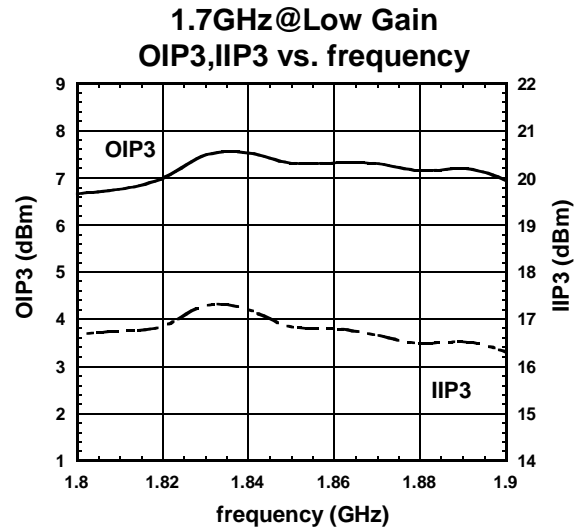

Condition

$T_a = +25^\circ\text{C}$,
 $f_1 = 1.8 \sim 1.9\text{GHz}$, $f_2 = f_1 + 100\text{kHz}$,
 $\text{Pin} = -16\text{dBm}$,
 $V_{DD} = V_{INV} = 2.7\text{V}$,
 $V_{CTL1} = 0\text{V}$, $V_{CTL2} = 1.85\text{V}$, $V_{CTL3} = 0\text{V}$

NJG1125PB5

ELECTRICAL CHARACTERISTICS (1.7GHz Band Low Gain Mode)

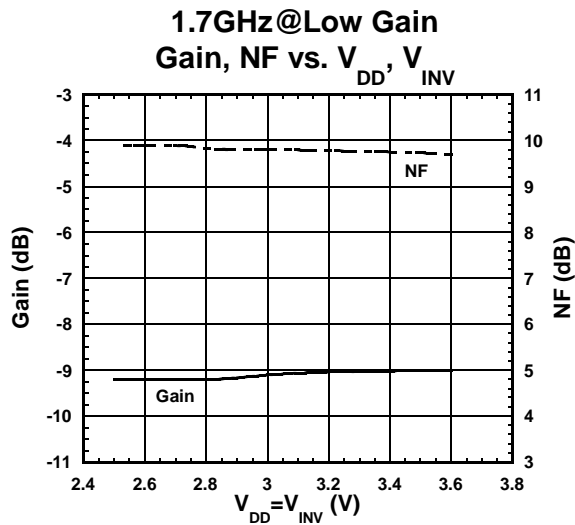

Condition
 Ta=+25°C,
 f=1860MHz,
 V_{CTL1}=0V, V_{CTL2}=1.85V, V_{CTL3}=0V

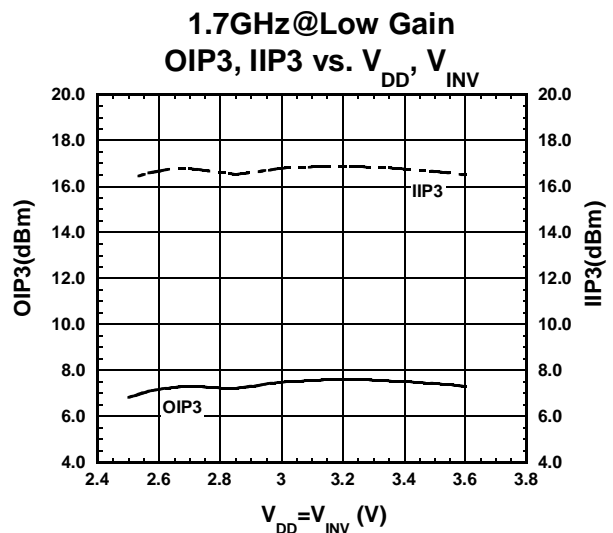

Condition
 Ta=+25°C,
 f1=1860MHz, f2=f1+100kHz,
 Pin=-16dBm,
 V_{CTL1}=0V, V_{CTL2}=1.85V, V_{CTL3}=0V

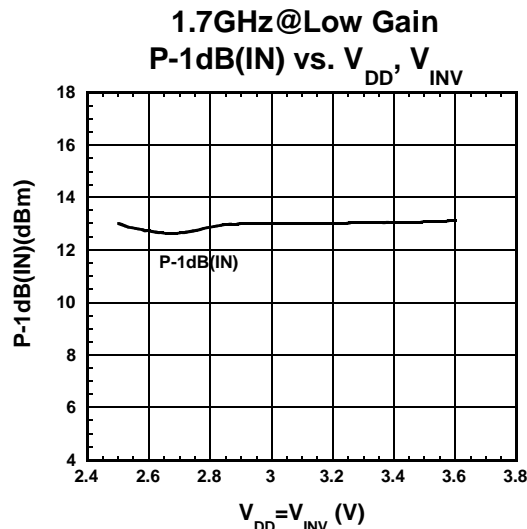

Condition
 Ta=+25°C,
 f=1860MHz,
 V_{CTL1}=0V, V_{CTL2}=1.85V, V_{CTL3}=0V

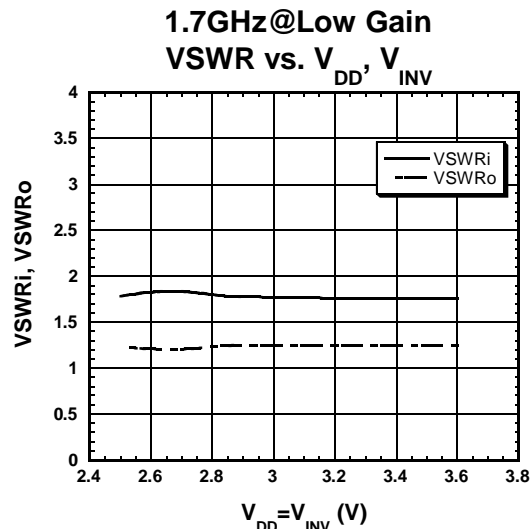

Condition
 Ta=+25°C,
 f=1860MHz,
 V_{CTL1}=0V, V_{CTL2}=1.85V, V_{CTL3}=0V

■ ELECTRICAL CHARACTERISTICS (1.7GHz Band Low Gain Mode)

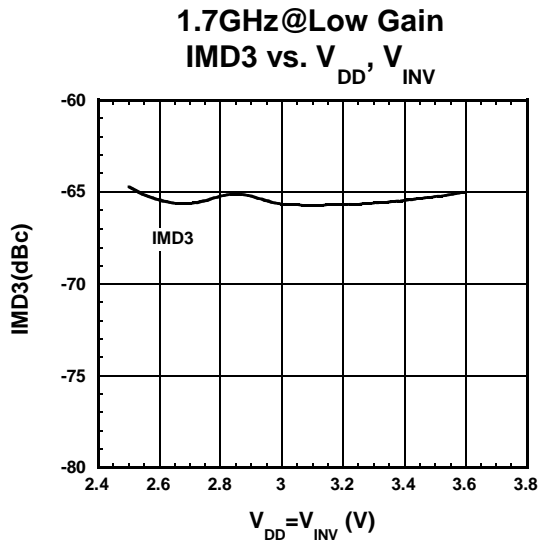

Condition

$T_a = +25^\circ\text{C}$,
 $f_1 = 1860\text{MHz}$, $f_2 = f_1 + 100\text{kHz}$,
 $P_{in} = -16\text{dBm}$,
 $V_{CTL1} = 0\text{V}$, $V_{CTL2} = 1.85\text{V}$, $V_{CTL3} = 0\text{V}$

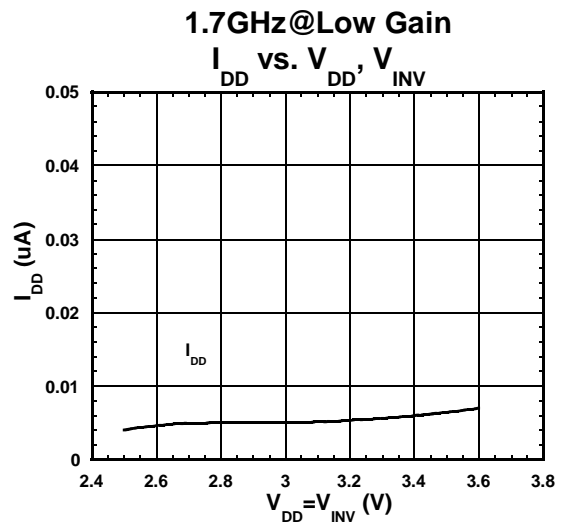

Condition

$T_a = +25^\circ\text{C}$,
 $\text{RF} = \text{OFF}$,
 $V_{CTL1} = 0\text{V}$, $V_{CTL2} = 1.85\text{V}$, $V_{CTL3} = 0\text{V}$

NJG1125PB5

ELECTRICAL CHARACTERISTICS (1.7GHz Band Low Gain Mode)

1.7GHz@Low Gain
Gain, NF vs. Temperature

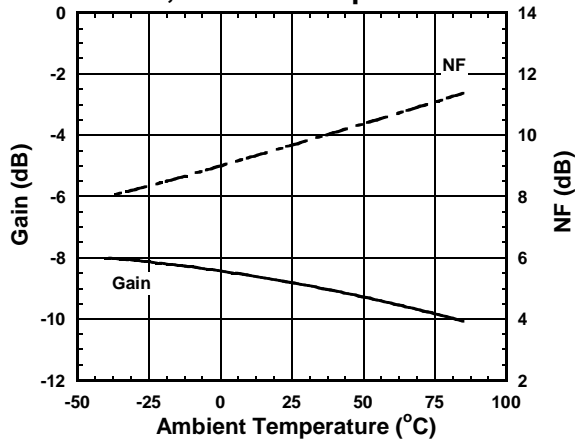

Condition

f=1860MHz,
 $V_{DD} = V_{INV} = 2.7V$,
 $V_{CTL1} = 0V$, $V_{CTL2} = 1.85V$, $V_{CTL3} = 0V$

1.7GHz@Low Gain
OIP3, IIP3 vs. Temperature

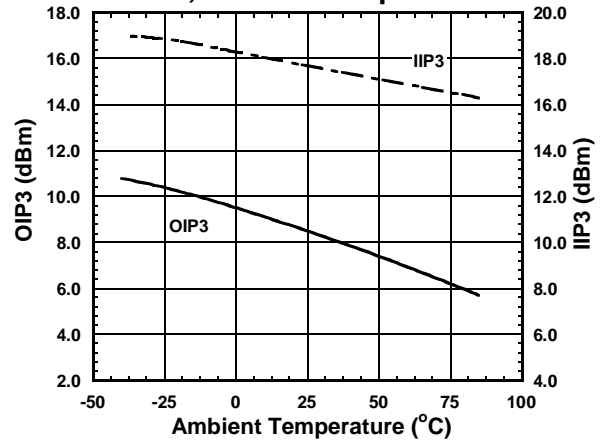

Condition

f1=1860MHz, f2=f1+100kHz,
 Pin=-16dBm,
 $V_{DD} = V_{INV} = 2.7V$,
 $V_{CTL1} = 0V$, $V_{CTL2} = 1.85V$, $V_{CTL3} = 0V$

1.7GHz@Low Gain
P-1dB(IN) vs. Temperature

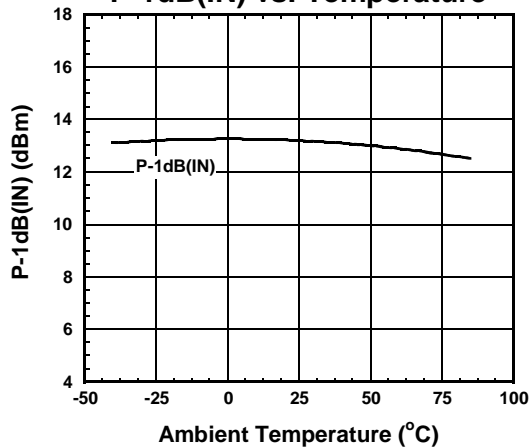

Condition

f=1860MHz,
 $V_{DD} = V_{INV} = 2.7V$,
 $V_{CTL1} = 0V$, $V_{CTL2} = 1.85V$, $V_{CTL3} = 0V$

1.7GHz@Low Gain
VSWR vs. Temperature

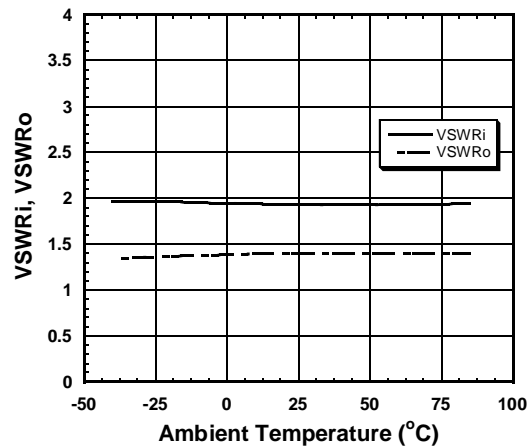

Condition

f=1860MHz,
 $V_{DD} = V_{INV} = 2.7V$,
 $V_{CTL1} = 0V$, $V_{CTL2} = 1.85V$, $V_{CTL3} = 0V$

■ ELECTRICAL CHARACTERISTICS (1.7GHz Band Low Gain Mode)

**1.7GHz@Low Gain
IMD3 vs. Temperature**

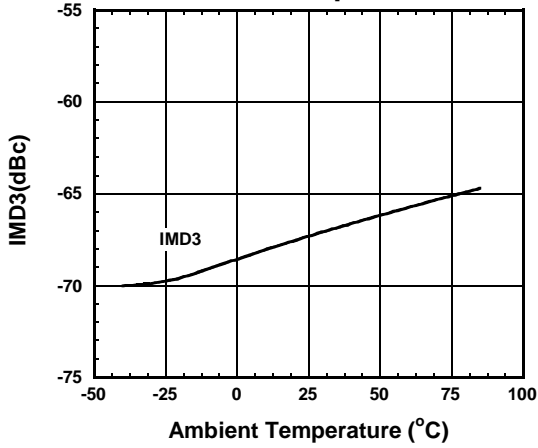

Condition

$f_1=1860\text{MHz}$, $f_2=f_1+100\text{kHz}$,
 $P_{in}=-16\text{dBm}$,
 $V_{DD}=V_{INV}=2.7\text{V}$,
 $V_{CTL1}=0\text{V}$, $V_{CTL2}=1.85\text{V}$, $V_{CTL3}=0\text{V}$

**1.7GHz@Low Gain
 I_{DD} vs. Temperature**

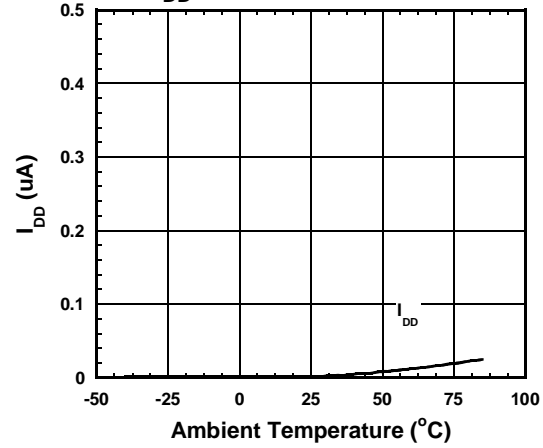

Condition

$RF=OFF$
 $V_{DD}=V_{INV}=2.7\text{V}$,
 $V_{CTL1}=0\text{V}$, $V_{CTL2}=1.85\text{V}$, $V_{CTL3}=0\text{V}$

NJG1125PB5

ELECTRICAL CHARACTERISTICS (1.7GHz Band Low Gain Mode)

Condition: $T_a = +25^\circ\text{C}$, $V_{DD} = V_{INV} = 2.7\text{V}$, $V_{CTL1} = 0\text{V}$, $V_{CTL2} = 1.85\text{V}$, $V_{CTL3} = 0\text{V}$

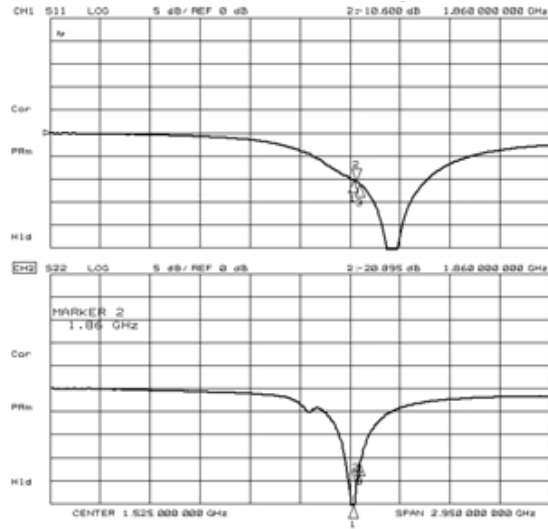

S11, S22

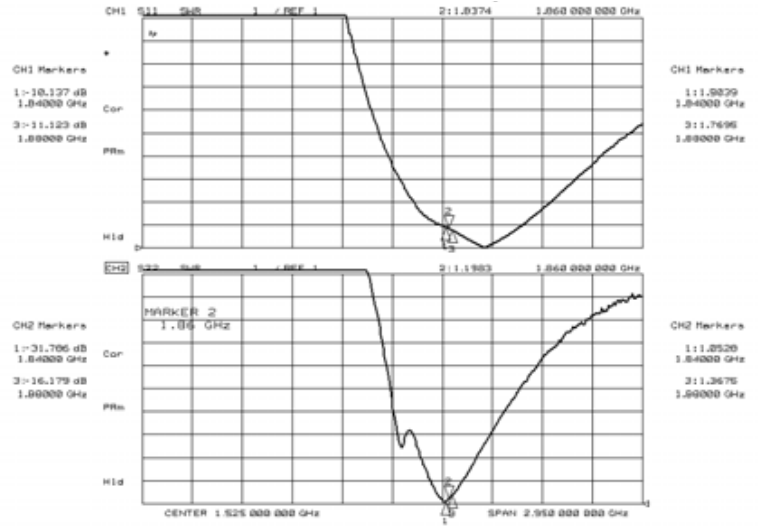

S21, S12

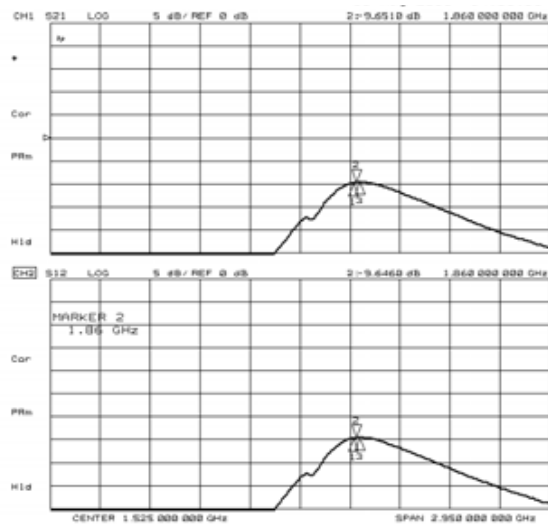

VSWR

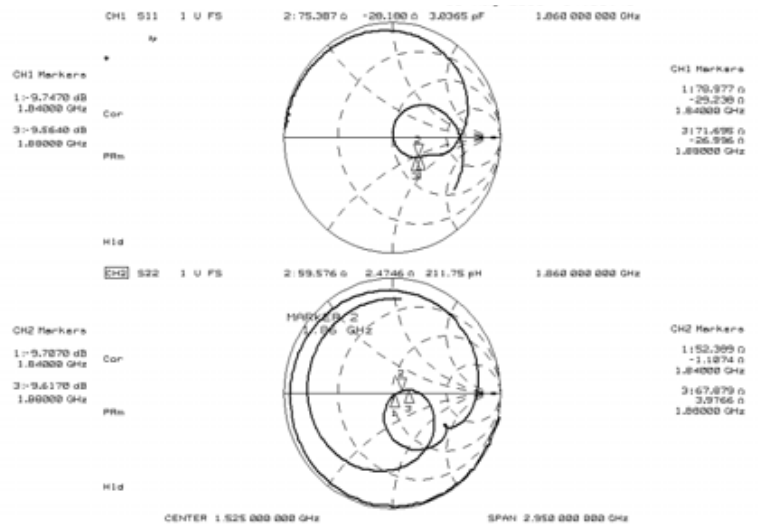

Zin, Zout

■ ELECTRICAL CHARACTERISTICS (1.7GHz Band Low Gain Mode)

Condition: $T_a=+25^{\circ}\text{C}$, $V_{DD}=V_{INV}=2.7\text{V}$, $V_{CTL1}=0\text{V}$, $V_{CTL2}=1.85\text{V}$, $V_{CTL3}=0\text{V}$

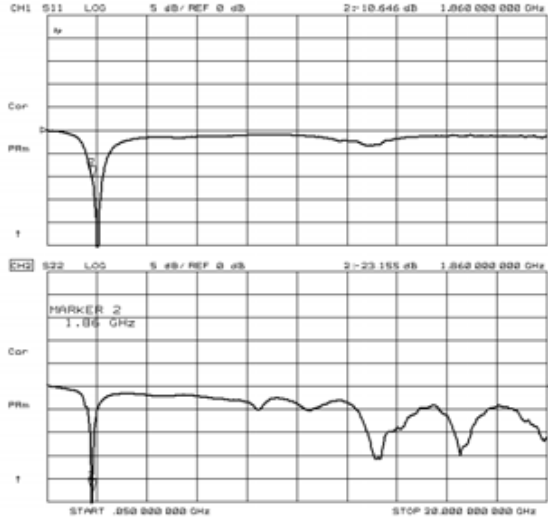

S11, S22
(f=50MHz~20GHz)

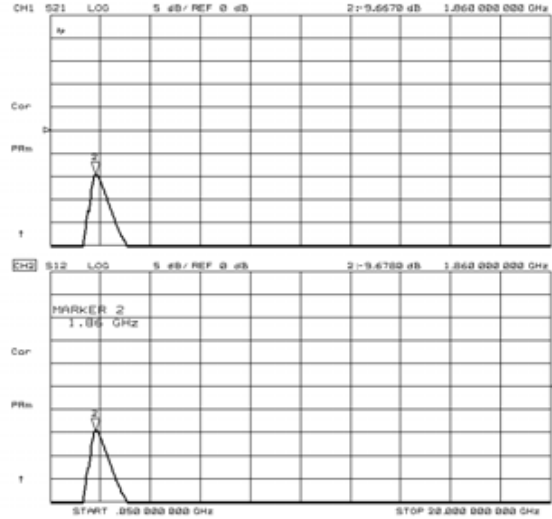

S21, S22
(f=50MHz~20GHz)

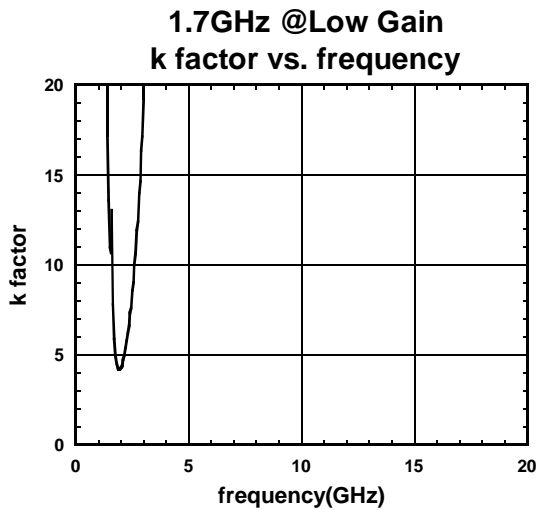

k factor
(f=50MHz~20GHz)

NJG1125PB5

TEST CIRCUIT

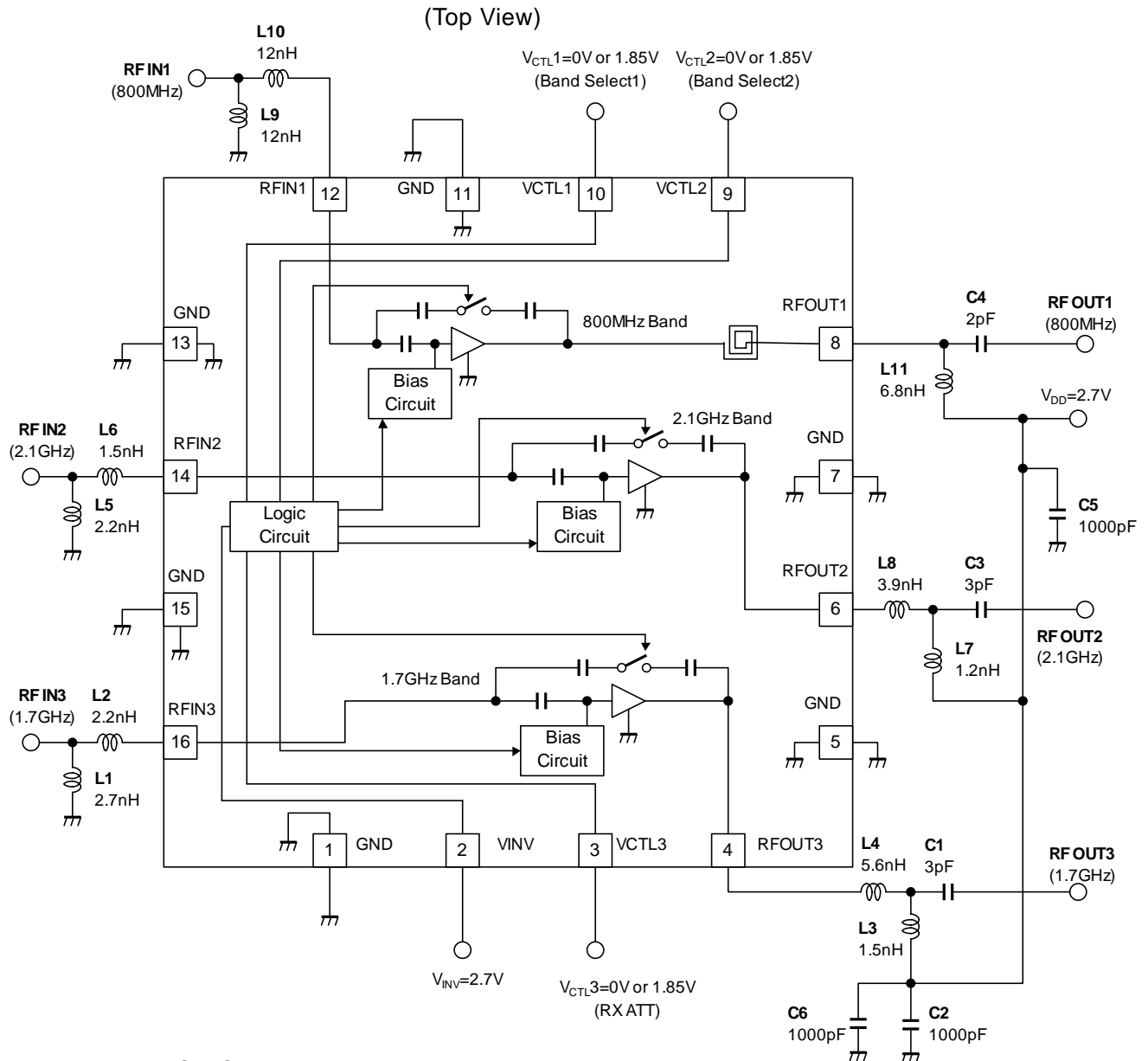

PARTS LIST

Parts ID	Comment
L1~ L11	MURATA (LQP03T) 0603size
C1~C6	MURATA (GRM03) 0603size

PRECAUTIONS

- 1) Please locate C2, C6 close to L3.
- 2) Please locate C4 close to L6, L10.
- 3) Ground terminal should be connected to the ground plane as low inductance as possible.

RECOMMENDED DESIGN

(Top View)

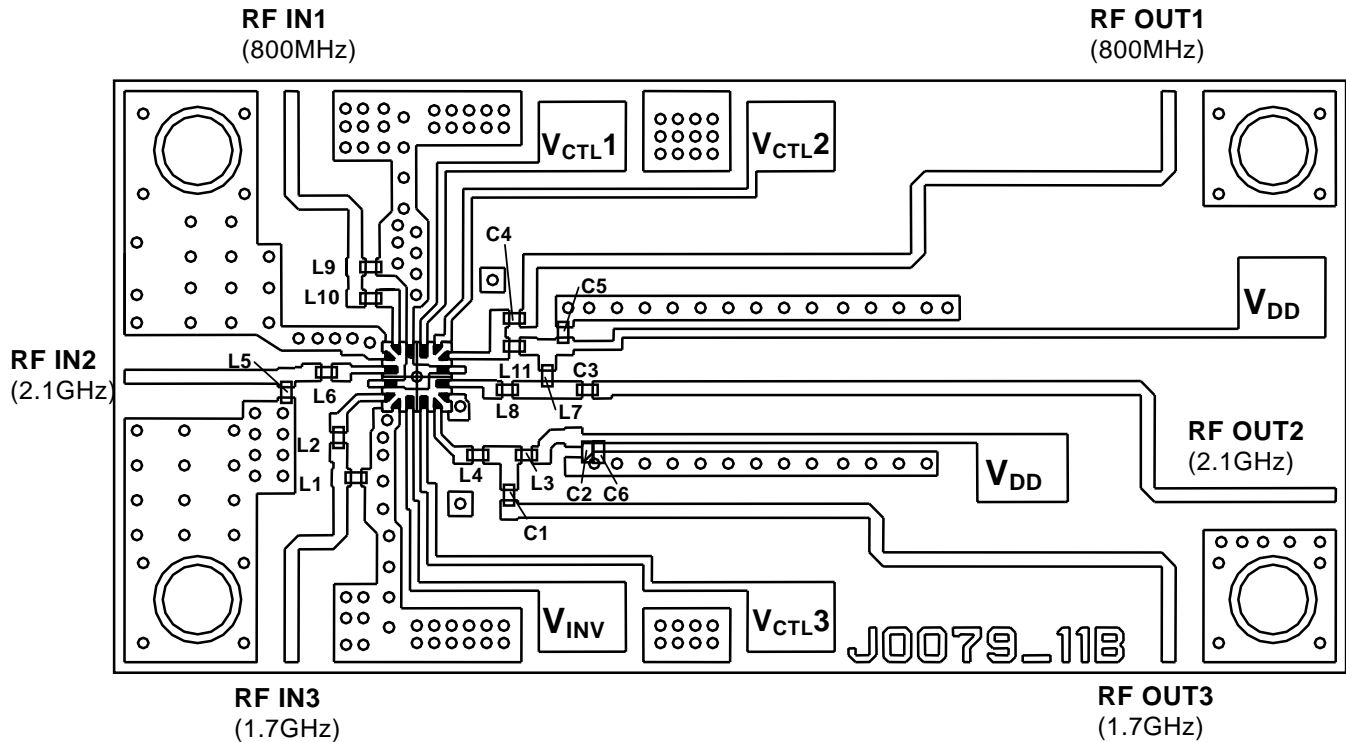

PCB (FR-4)
 t=0.2mm
 MICROSTRIP LINE WIDTH=0.4mm ($Z_0=50\text{ohm}$)
 PCB SIZE=35.4mm X 17.0mm

NJG1125PB5

MEASUREMENT BLOCK DIAGRAM

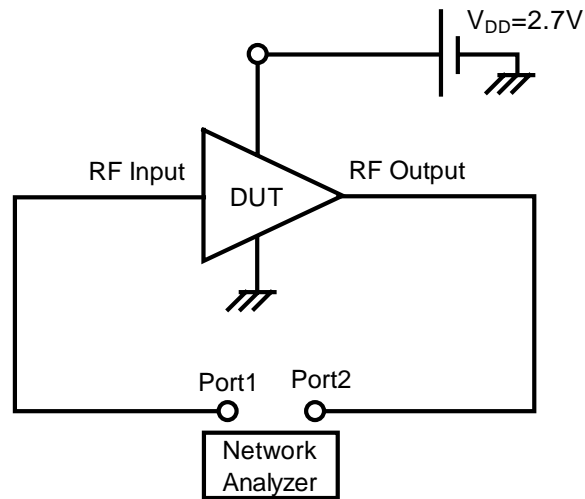

S parameter Measurement Block Diagram

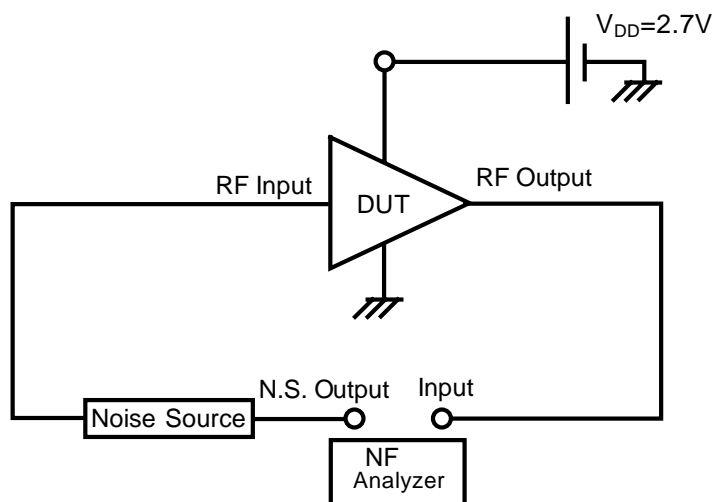

Noise Figure Measurement Block Diagram

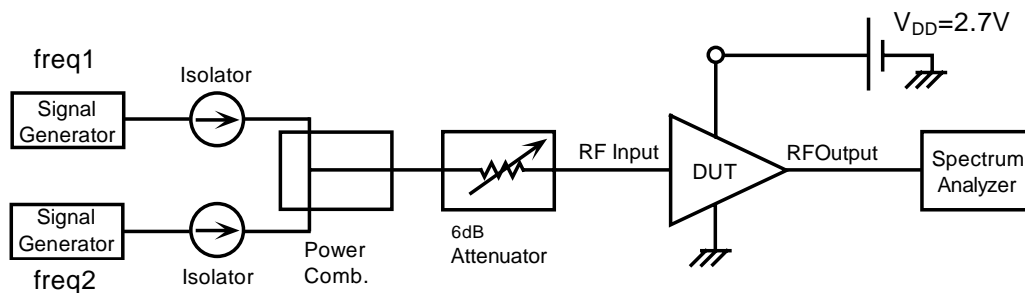

IF and IM3 measurement for IIP3

PACKAGE OUTLINE (FFP16-B5)

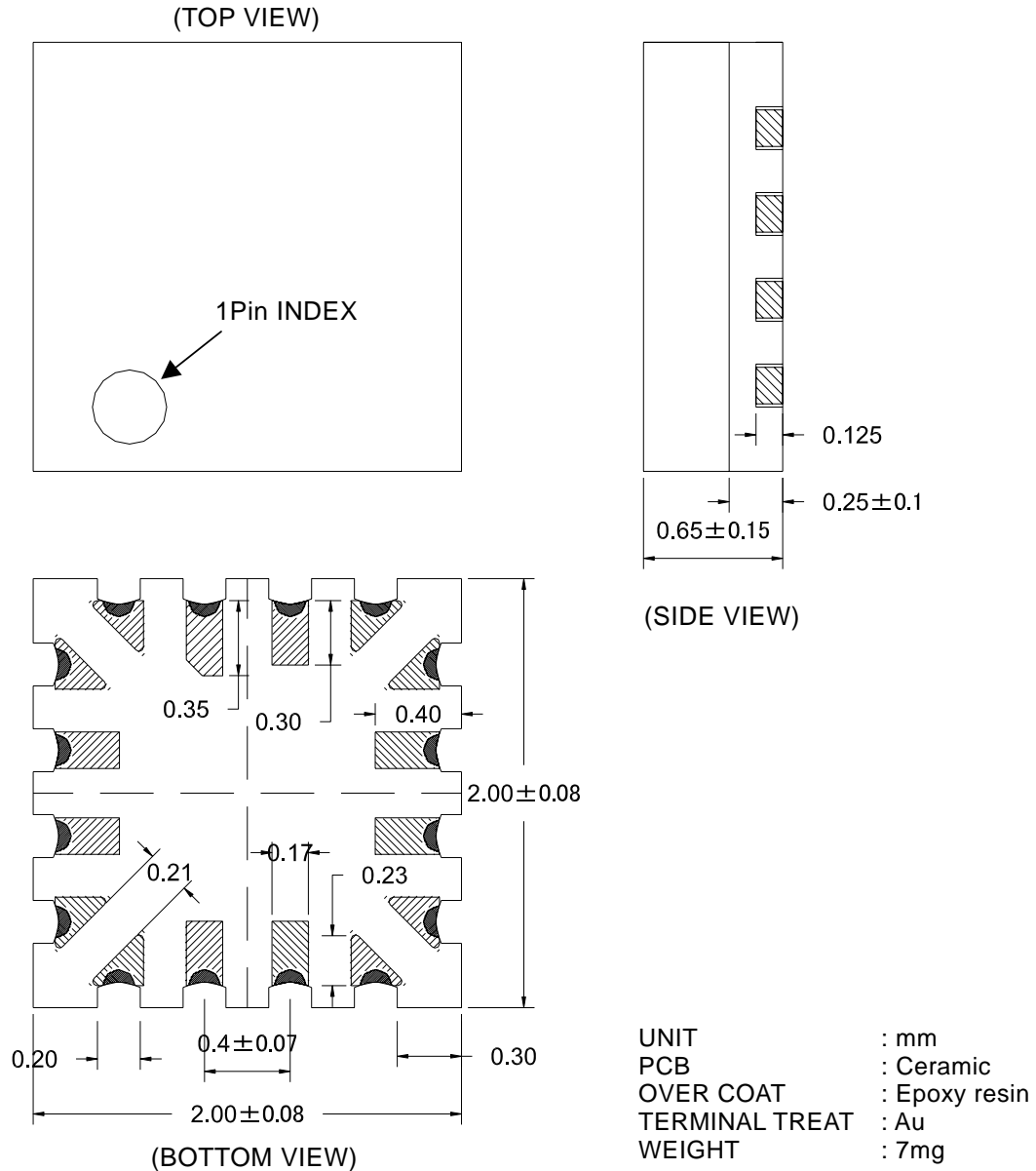

Cautions on using this product

This product contains Gallium-Arsenide (GaAs) which is a harmful material.

- Do NOT eat or put into mouth.
- Do NOT dispose in fire or break up this product.
- Do NOT chemically make gas or powder with this product.
- To waste this product, please obey the relating law of your country.

[CAUTION]

The specifications on this databook are only given for information, without any guarantee as regards either mistakes or omissions. The application circuits in this databook are described only to show representative usages of the product and not intended for the guarantee or permission of any right including the industrial rights.

This product may be damaged with electric static discharge (ESD) or spike voltage. Please handle with care to avoid these damages.