

PHS Transceiver GaAs MMIC

GENERAL DESCRIPTION

NJG1723KT2 is a GaAs multi-function MMIC composed of a power amplifier, a SPDT switch and a LNA+MIXER for Japanese PHS or WLL application.

NJG1723KT2 is operated at low voltage, and includes a low current and low distortion PA, a low insertion loss antenna switch and a low noise and high gain LNA+MIXER.

The small QFN24-T2 package is applied.

PACKAGE OUTLINE

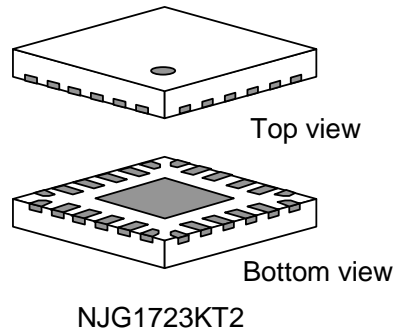

FEATURES

○DC Characteristic

- Low current consumption

○Tx High Power mode (PA+ANT SW):

- High gain
- Adjacent channel leak power ratio

○Tx Low Power mode (PA+ANT SW):

- High gain
- Adjacent channel leak power ratio

○Rx mode (ANT SW+LNA+MIXER)

- High conversion gain
- Low noise figure
- High input IP3

Tx (High Power mode): 240mA typ.

Tx (Low Power mode): 180mA typ.

Rx: 8.3mA typ.

Pout=+23.2dBm

38.0dB typ.

-58dBc max. @offset 600kHz

-63dBc max. @offset 900kHz

Pout=+20.2dBm

37.5dB typ.

-55dBc max. @offset 600kHz

-60dBc max. @offset 900kHz

20.5dB typ. @ P_{LO}=-15dBm

2.6dB typ. @ P_{LO}=-15dBm

-10dBm typ. @ P_{LO}=-15dBm

PIN CONFIGURATION

(Top View)

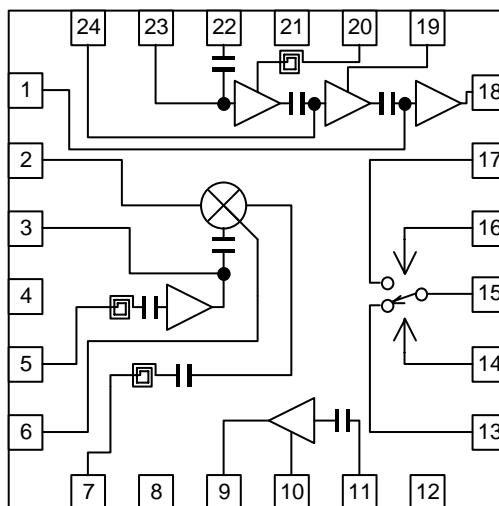

Pin Connection

1. VBB3	13. P2
2. IFOUT	14. VCTL2
3. VLO	15. PC
4. NC(GND)	16. VCTL1
5. LOIN	17. P1
6. BPC	18. PAOUT
7. MIXIN	19. VCC2
8. GND1	20. VCC1
9. LNAOUT	21. GND3
10. LNACAP	22. PAIN
11. LNAIN	23. VBB1
12. GND2	24. VBB2

●Exposed PAD: GND

NOTE: Please note that any information on this catalog will be subject to change.

NJG1723KT2

■ ABSOLUTE MAXIMUM RATINGS

(T_a=+25°C)

PARAMETER	SYMBOL	CONDITIONS	RATINGS	UNITS
Supply Voltage	V _{CC}		5.0	V
Base Voltage	V _{BB}		2.0	V
V _{CC} Terminal Current	I _{CC}		360	mA
Control Voltage1, 2	V _{CTL1, 2}		7.5	V
LNA Voltage	V _{LNA}		5.0	V
MIXER Voltage	V _{MIX}		5.0	V
Local Amplifier Voltage	V _{LO}		5.0	V
Input Power 1 (PA IN terminal)	P _{PAIN}	Idle=200mA	+3.0	dBm
Input Power 2 (ANT terminal)	P _{ANTIN}	V _{LNA} =V _{MIX} =V _{LO} =2.7V	-5.0	dBm
Input Power 3 (LOCAL IN terminal)	P _{LOIN}	V _{LNA} =V _{MIX} =V _{LO} =2.7V	+10.0	dBm
Power Dissipation	P _D	At on PCB (FR4), T _j =150°C	1000	mW
Operating Temperature	T _{opr}		-20~+85	°C
Storage Temperature	T _{stg}		-55~+150	°C

■ ELECTRICAL CHARACTERISTICS 1 (DC)

GENERAL CONDITIONS: T_a=+25°C, V_{CC}=3.3V, V_{CTL(L)}=0V, V_{CTL(H)}=2.7V, V_{LNA}=V_{MIX}=V_{LO}=2.7V

PARAMETER	SYMBOL	CONDITIONS	MIN	TYP	MAX	UNITS
Supply Voltage	V _{CC}		2.7	3.3	5.0	V
Base Voltage1	V _{BB1}	I _{CC1} =240mA	1.2	1.5	1.8	V
Idle Current1	I _{idle1}	PA IN: No signal	-	200	240	mA
Base Current1	I _{BB1}	PA IN: No signal	-	2.0	2.3	mA
Base Voltage2	V _{BB2}	I _{CC2} =180mA	1.0	1.4	1.8	V
Idle Current2	I _{idle2}	PA IN: No signal	-	165	185	mA
Base Current2	I _{BB2}	PA IN: No signal	-	1.4	1.7	mA
Operating Voltage (Low)	V _{CTL(L)}		-0.2	0	0.2	V
Operating Voltage (High)	V _{CTL(H)}		2.5	2.7	6.5	V
Control Current	I _{CTL}	PA IN, RF, LO: No signal	-	8.0	14.0	uA
LNA Voltage	V _{LNA}		2.5	2.7	4.5	V
LNA Operating Current	I _{LNA}	P _{RF} , P _{LO} =OFF	-	2.8	3.5	mA
MIXER Operating Voltage	V _{MIX}		2.5	2.7	4.5	V
MIXER Current	I _{MIX}	P _{RF} , P _{LO} =OFF	-	4.6	5.7	mA
Local Amplifier Voltage	V _{LO}		2.5	2.7	4.5	V
Local Amplifier Operating Current	I _{LO}	P _{RF} , P _{LO} =OFF	-	0.9	1.3	mA

■ ELECTRICAL CHARACTERISTICS 2 High Power Mode (TX: PA+ANT SW)

GENERAL CONDITIONS: $T_a=+25^{\circ}\text{C}$, $V_{CC}=3.3\text{V}$, $V_{CTL1}=2.7\text{V}$, $V_{CTL2}=0\text{V}$, $f_{RF}=1900\text{MHz}$,
 $P_{OUT}=+23.2\text{dBm}$, $Z_s=Z_l=50\Omega$

PARAMETER	SYMBOL	CONDITIONS	MIN	TYP	MAX	UNITS
Operating Frequency	freq		1880	1900	1920	MHz
V_{CC} Terminal Current1	I_{CC1}		-	240	-	mA
Power Gain1	G_{p1}		35.0	38.0	-	dB
Gain Flatness1	$G_{flat\ TX1}$	$f_{RF}=1880\sim 1920\text{MHz}$	-	0.5	1.0	dB
Pout at 1dB Gain Compression Point1	$P_{-1dB\ TX1}$		+21	+24	-	dBm
Adjacent Channel leak Power Ratio1	ACPR1	Pin: $\pi/4$ QPSK, Burst off, offset 600kHz	-	-63	-58	dBc
Adjacent Channel leak Power Ratio2	ACPR2	Pin: $\pi/4$ QPSK, Burst off, offset 900kHz	-	-70	-63	dBc
Harmonics1	Phm1	2nd Harmonics and 3rd Harmonics	-	-35	-30	dBc
Occupied bandwidth1	OBW1		-	250	275	kHz
PA IN VSWR1	VSWR1	Small signal PA IN terminal	-	1.5	2.0	
ANT VSWR2 (Transmit active)	VSWR2	Small signal ANT terminal	-	1.5	2.0	

■ ELECTRICAL CHARACTERISTICS 3 Low Power Mode (TX: PA+ANT SW)

GENERAL CONDITIONS: $T_a=+25^{\circ}\text{C}$, $V_{CC}=3.3\text{V}$, $V_{CTL1}=2.7\text{V}$, $V_{CTL2}=0\text{V}$, $f_{RF}=1900\text{MHz}$,
 $P_{OUT}=+20.2\text{dBm}$, $Z_s=Z_l=50\Omega$

PARAMETER	SYMBOL	CONDITIONS	MIN	TYP	MAX	UNITS
Operating Frequency	freq		1880	1900	1920	MHz
V_{CC} Terminal Current2	I_{CC2}		-	180	-	mA
Power Gain2	G_{p2}		34.0	37.5	-	dB
Gain Flatness2	$G_{flat\ TX2}$	$f_{RF}=1880\sim 1920\text{MHz}$	-	0.5	1.0	dB
Pout at 1dB Gain Compression Point2	$P_{-1dB\ TX2}$		+19	+21	-	dBm
Adjacent Channel leak Power Ratio3	ACPR3	Pin: $\pi/4$ QPSK, Burst off, offset 600kHz	-	-63	-55	dBc
Adjacent Channel leak Power Ratio4	ACPR4	Pin: $\pi/4$ QPSK, Burst off, offset 900kHz	-	-70	-60	dBc
Harmonics2	Phm2	2nd Harmonics and 3rd Harmonics	-	-35	-30	dBc
Occupied bandwidth2	OBW2		-	250	275	kHz
PA IN VSWR3	VSWR3	Small signal PA IN terminal	-	1.5	2.0	
ANT VSWR4 (Transmit active)	VSWR4	Small signal ANT terminal	-	1.5	2.0	

NJG1723KT2

■ ELECTRICAL CHARACTERISTICS 4 (RX: ANT SW+LNA+MIXER)

GENERAL CONDITIONS: $T_a=+25^{\circ}\text{C}$, $V_{\text{CTL1}}=0\text{V}$, $V_{\text{CTL2}}=V_{\text{LNA}}=V_{\text{MIX}}=V_{\text{LO}}=2.7\text{V}$, $f_{\text{RF}}=1900\text{MHz}$, $f_{\text{LO}}=1660\text{MHz}$, $P_{\text{RF}}=-45\text{dBm}$, $P_{\text{LO}}=-15\text{dBm}$, $Z_s=Z_l=50\Omega$

PARAMETER	SYMBOL	CONDITIONS	MIN	TYP	MAX	UNITS
Operating Frequency	freq		1880	1900	1920	MHz
LNA Operating Current	ILNA		-	2.8	3.5	mA
MIXER Operating Current	IMIX		-	4.6	5.7	mA
LNA Operating Current	ILO		-	0.9	1.3	mA
Conversion Gain	Gc		16.5	20.5	-	dB
Gain Flatness	Gflat _{RX}	$f_{\text{RF}}=1880\sim 1920\text{MHz}$	-	0.5	1.5	dB
Noise Figure	NF	SSB	-	2.6	3.5	dB
Input 3rd order Intercept Point	IIP3	$f_{\text{RF}}=1900.0+1900.6\text{MHz}$	-14	-10	-	dBm
Pin at 1dB Gain Compression Point	P _{-1dB RX}		-25.5	-21.5	-	dBm
Image suppression ratio	IMR	$f_{\text{RF}}=1900/1420\text{MHz}$	31	36	-	dB
1/2 IF suppression ratio	1/2IFR	$f_{\text{RF}}=1900/1780\text{MHz}$	49	55	-	dB
2xLO-IF suppression ratio	SPR1	$f_{\text{RF}}=1900/3080\text{MHz}$	39	47	-	dB
2xLO+IF suppression ratio	SPR2	$f_{\text{RF}}=1900/3560\text{MHz}$	24	62	-	dB
LO to ANT leak	Plk		-	-55	-45	dBm
ANT VSWR (Receive active)	VSWR5		-	1.5	2.0	
LOCAL IN VSWR	VSWR6		-	2.0	2.5	
IF OUT VSWR	VSWR7		-	1.5	2.0	

■ TRUTH TABLE

Control Voltage: "High"= $V_{\text{CTL(H)}}$, "Low"= $V_{\text{CTL(L)}}$

Pass	VCTL1	VCTL2
PC(ANT)-P1(TX)	High	Low
PC(ANT)-P2(RX)	Low	High

■ TERMINAL INFORMATION

No.	SYMBOL	DESCRIPTION
1	VBB3	This terminal is for base bias supply of the 3rd stage of power amplifier. Operation current of the power amplifier is adjusted by changing the bias voltage applied to this terminal. Please connect bypass capacitors C13 and C14 with ground plane close to this terminal. Please connect pin 23 and pin 24, and connect the resistor R1 for temperature characteristic compensation of PA gain.
2	IFOUT	IF signal output terminal. The IF signal is output through external matching circuit connected to this terminal. Please connect inductances L7, L8 and power supply as shown in the application circuit, since this terminal is also the terminal of mixer power supply.
3	VLO	Power supply terminal for local amplifier. Please place L6 and C9 shown in the application circuit, very close to this terminal.
4	NC(GND)	Nonconnection terminal. Please connect with Ground terminal.
5	LOIN	Local signal input terminal connected to the local amplifier. An external matching circuit is required.
6	BPC	Terminal to connect to the external bypass capacitor of mixer. The bypass capacitor C8 shown in the application circuit should be connected to this terminal as close as possible.
7	MIXIN	Input terminal of RF signal to the mixer. An external matching circuit is required.
8	GND1	Ground terminal (0V)
9	LNAOUT	Output terminal of LNA. The RF signal from LNA goes out through external matching circuit connected to this terminal. Please connect inductances L4, L5 and power supply as shown in the application circuit, since this terminal is also the terminal of LNA power supply.
10	LNACAP	Terminal to connect to an external bypass capacitor of LNA. The bypass capacitor C5 shown in the application circuit should be connected to this terminal as close as possible.
11	LNAIN	RF input terminal of LNA. An external matching circuit is required.
12	GND2	Ground terminal (0V)
13	P2	RF port. This terminal is one of ports of SPDT SW. This terminal connects to PC terminal (pin 15) when logical high voltage signal is supplied to VCTL2 (pin 14) and logical low voltage signal is supplied to VCTL1 (pin 16). External capacitor C3 is required to block the DC bias voltage of internal circuit.

No.	SYMBOL	DESCRIPTION
14	VCTL2	Control port. Please connect bypass capacitor C2 with ground plane close to this terminal.
15	PC	Common RF port. The terminal PC is connected to the terminal P1 or the terminal P2 by the voltage supplied to the terminal VCTL1 and VCTL2. In order to block the DC bias voltage of internal circuit, external capacitor C1 is required.
16	VCTL1	Control port. Please connect bypass capacitor C25 with ground plane close to this terminal.
17	P1	RF port. This terminal is one of ports of SPDT SW. This terminal connects to PC terminal (pin 15) when logical low voltage signal is supplied to VCTL2 (pin 14) and logical high voltage signal is supplied to VCTL1 (pin 16). External capacitor C23 is required to block the DC bias voltage of internal circuit.
18	PAOUT	Output terminal of power amplifier. The RF signal from power amplifier goes out through an external matching circuit connected to this terminal. Moreover, this terminal should be connected to DC power supply through inductor L10 shown in the application circuit, since it is the terminal for power supply of the 3rd stage of Power Amplifier.
19	VCC2	This terminal is for DC power supply of the 2nd stage of power amplifier.
20	VCC1	This terminal is for DC power supply of the 1st stage of power amplifier. Please place bypass capacitors C16 and C17 between this terminal and GND as near as possible.
21	GND3	Ground terminal (0V)
22	PAIN	RF input terminal of power amplifier.
23	VBB1	This terminal is for base bias supply of the 1st stage of power amplifier. Operation current of the power amplifier is adjusted by changing the bias voltage applied to this terminal. Please connect bypass capacitors C13 and C14 with ground plane close to this terminal. Please connect pin 24 and pin 1, and connect the resistor R1 for temperature characteristic compensation of PA gain.
24	VBB2	This terminal is for base bias supply of the 2nd stage of Power Amplifier. Operation current of the power amplifier is adjusted by changing the bias voltage applied to this terminal. Please connect bypass capacitors C13 and C14 with ground plane close to this terminal. Please connect pin 23 and pin 1, and connect the resistor R1 for temperature characteristic compensation of PA gain.

■ TYPICAL CHARACTERISTICS (High Power Mode, TX: PA + ANT SW SECTION)

Output Power, Gp vs. Input Power

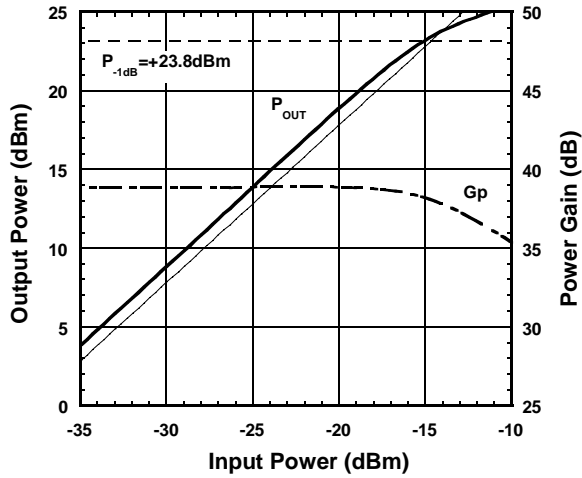

Condition
 $f_{RF} = 1900 \text{ MHz (CW)}$, $T_a = +25^\circ \text{C}$
 $V_{BB1} = \text{Const. (@} ICC1 = 240 \text{ mA, } P_{out} = +23.2 \text{ dBm)}$
 $V_{CC} = 3.3 \text{ V}$, $V_{CTL1} = 2.7 \text{ V}$
 $V_{CTL2} = V_{LNA} = V_{MIX} = V_{LO} = 0 \text{ V}$

Output Power, ACPR vs. Input Power

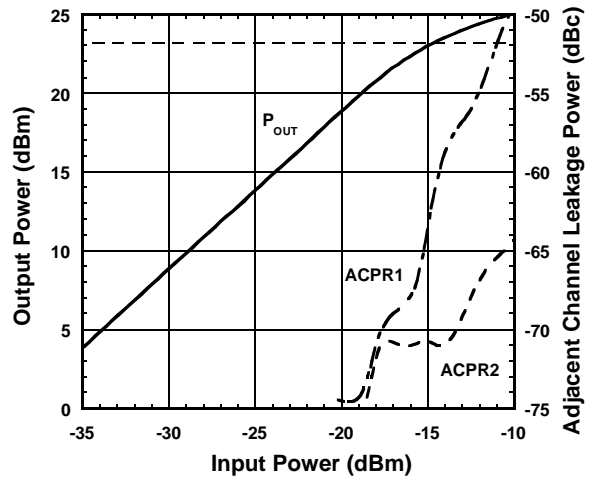

Condition
 $f_{RF} = 1900 \text{ MHz } (\pi/4 \text{ DQPSK})$, $T_a = +25^\circ \text{C}$
 $V_{BB1} = \text{Const. (@} ICC1 = 240 \text{ mA, } P_{out} = +23.2 \text{ dBm)}$
 $V_{CC} = 3.3 \text{ V}$, $V_{CTL1} = 2.7 \text{ V}$
 $V_{CTL2} = V_{LNA} = V_{MIX} = V_{LO} = 0 \text{ V}$

Output Power, ICC vs. Input Power

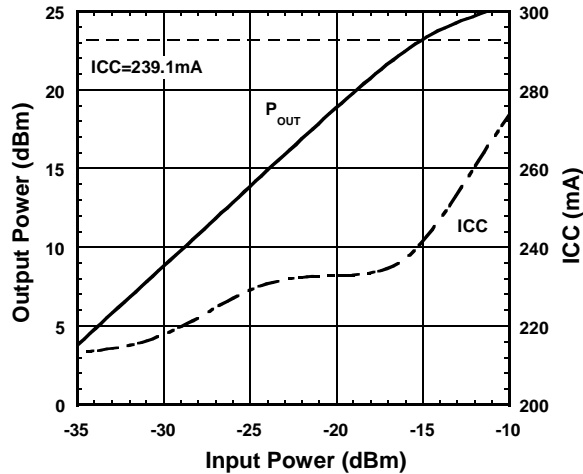

Condition
 $f_{RF} = 1900 \text{ MHz (CW)}$, $T_a = +25^\circ \text{C}$
 $V_{BB1} = \text{Const. (@} ICC1 = 240 \text{ mA, } P_{out} = +23.2 \text{ dBm)}$
 $V_{CC} = 3.3 \text{ V}$, $V_{CTL1} = 2.7 \text{ V}$
 $V_{CTL2} = V_{LNA} = V_{MIX} = V_{LO} = 0 \text{ V}$

Output Power, PAE vs. Input Power

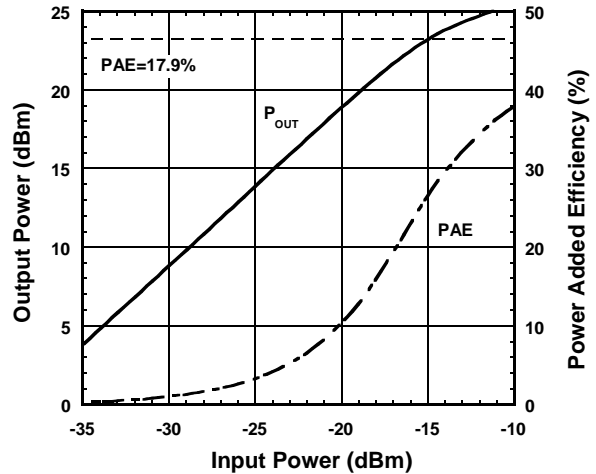

Condition
 $f_{RF} = 1900 \text{ MHz (CW)}$, $T_a = +25^\circ \text{C}$
 $V_{BB1} = \text{Const. (@} ICC1 = 240 \text{ mA, } P_{out} = +23.2 \text{ dBm)}$
 $V_{CC} = 3.3 \text{ V}$, $V_{CTL1} = 2.7 \text{ V}$
 $V_{CTL2} = V_{LNA} = V_{MIX} = V_{LO} = 0 \text{ V}$

NJG1723KT2

■ TYPICAL CHARACTERISTICS (High Power Mode, TX: PA + ANT SW SECTION)

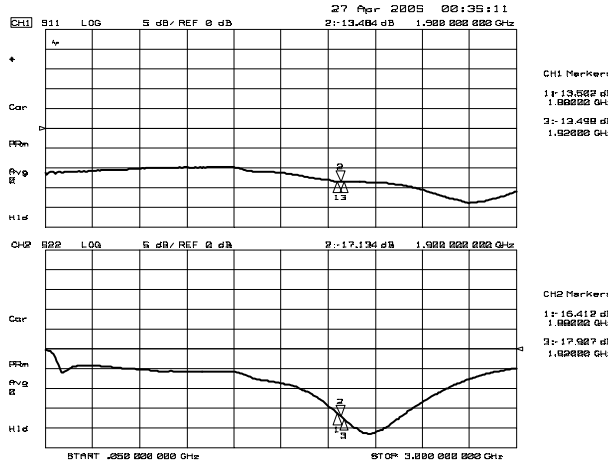

Condition
 Ta=+25°C
 V_{BB1}=Const. (@ICC1=240mA, Pout=+23.2dBm)
 V_{CC}=3.3V, V_{CTL1}=2.7V
 V_{CTL2}=V_{LNA}=V_{MIX}=V_{LO}=0V

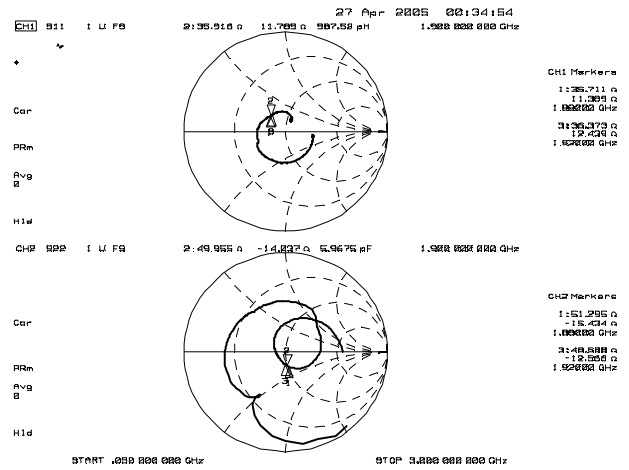

Condition
 Ta=+25°C
 V_{BB1}=Const. (@ICC1=240mA, Pout=+23.2dBm)
 V_{CC}=3.3V, V_{CTL1}=2.7V
 V_{CTL2}=V_{LNA}=V_{MIX}=V_{LO}=0V

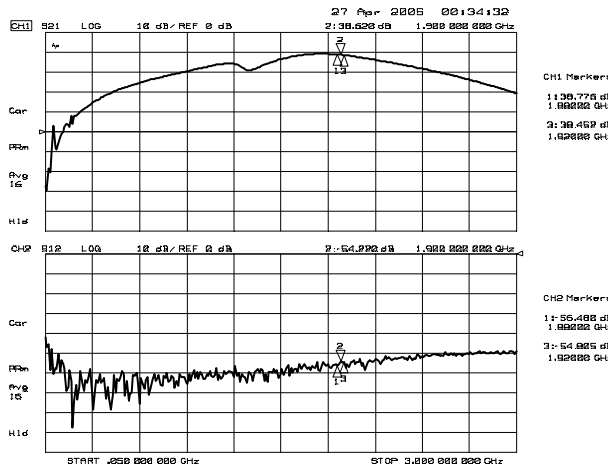

Condition
 Ta=+25°C
 V_{BB1}=Const. (@ICC1=240mA, Pout=+23.2dBm)
 V_{CC}=3.3V, V_{CTL1}=2.7V
 V_{CTL2}=V_{LNA}=V_{MIX}=V_{LO}=0V

■ TYPICAL CHARACTERISTICS (High Power Mode, TX: PA + ANT SW SECTION)

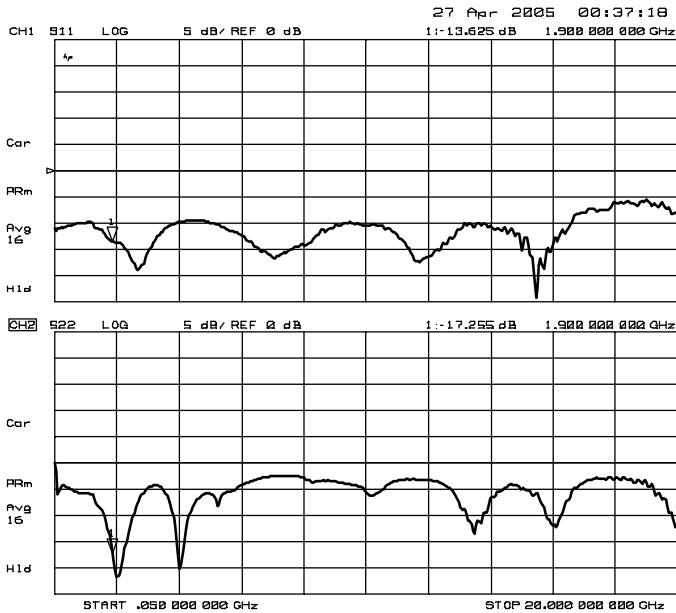

Condition

$T_a = +25^\circ\text{C}$

$V_{BB1} = \text{Const.} (@ ICC1 = 240\text{mA}, P_{out} = +23.2\text{dBm})$

$V_{CC} = 3.3\text{V}, V_{CTL1} = 2.7\text{V}$

$V_{CTL2} = V_{LNA} = V_{MIX} = V_{LO} = 0\text{V}$

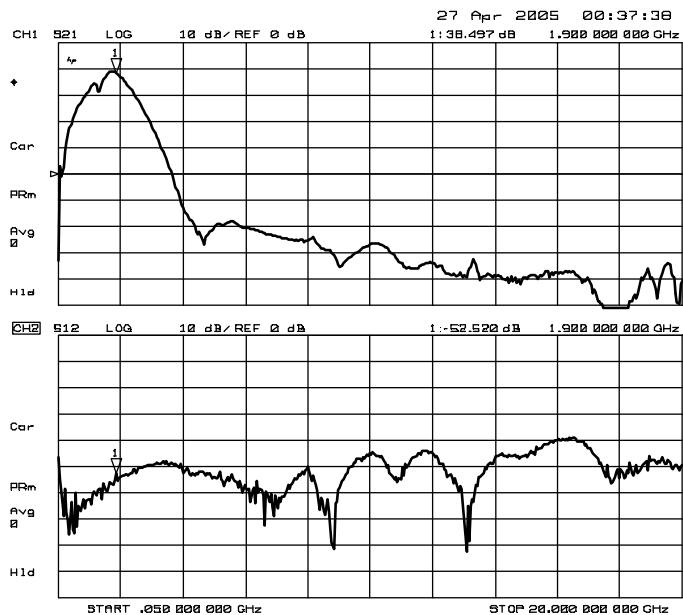

Condition

$T_a = +25^\circ\text{C}$

$V_{BB1} = \text{Const.} (@ ICC1 = 240\text{mA}, P_{out} = +23.2\text{dBm})$

$V_{CC} = 3.3\text{V}, V_{CTL1} = 2.7\text{V}$

$V_{CTL2} = V_{LNA} = V_{MIX} = V_{LO} = 0\text{V}$

■ TYPICAL CHARACTERISTICS (High Power Mode, TX: PA + ANT SW SECTION)

Gp, P_{-1dB} vs. V_{BB} Terminal Voltage

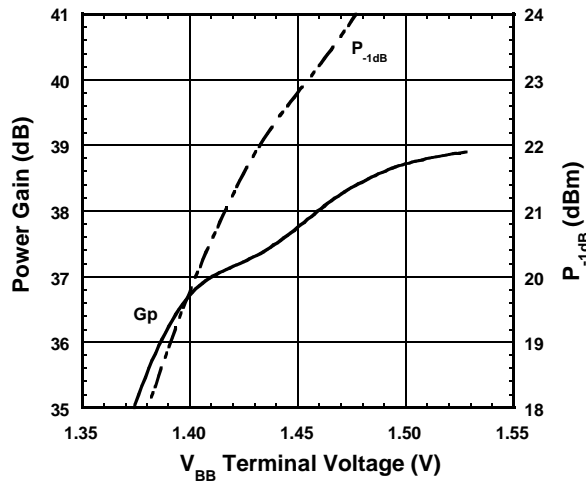

Condition
 $f_{RF}=1900\text{MHz(CW)}$, $T_a=+25^\circ\text{C}$
 $P_{RF}=\text{Const. (ICC1}=240\text{mA}@V_{CC}=3.3\text{V, } P_{out}=+23.2\text{dBm})$
 $V_{CC}=3.3\text{V}$, $V_{CTL1}=2.7\text{V}$
 $V_{CTL2}=V_{LNA}=V_{MIX}=V_{LO}=0\text{V}$

ACPR1, ACPR2 vs. V_{BB} Terminal Voltage

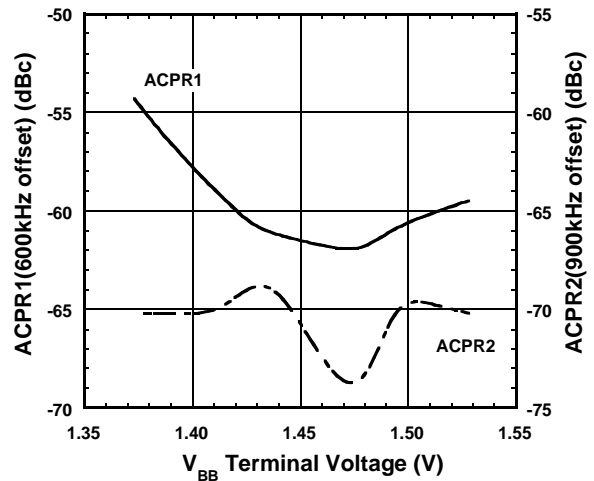

Condition
 $f_{RF}=1900\text{MHz}(\pi/4\text{DQPSK})$, $T_a=+25^\circ\text{C}$
 $P_{RF}=\text{Const. (ICC1}=240\text{mA}@V_{CC}=3.3\text{V, } P_{out}=+23.2\text{dBm})$
 $V_{CC}=3.3\text{V}$, $V_{CTL1}=2.7\text{V}$
 $V_{CTL2}=V_{LNA}=V_{MIX}=V_{LO}=0\text{V}$

Idle, I_{BB} vs. V_{BB} Terminal Voltage

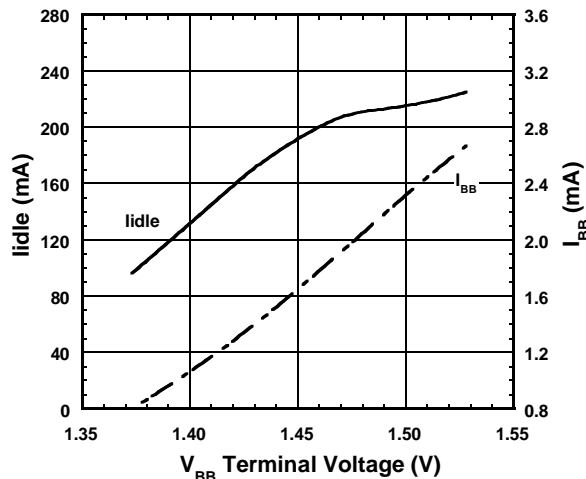

Condition
 $T_a=+25^\circ\text{C}$
 $V_{CC}=3.3\text{V}$, $V_{CTL1}=2.7\text{V}$
 $V_{CTL2}=V_{LNA}=V_{MIX}=V_{LO}=0\text{V}$

ICC, IBB vs. V_{BB} Terminal Voltage

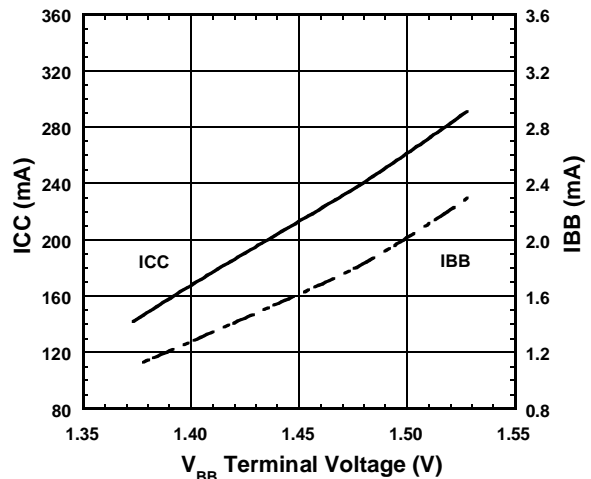

Condition
 $f_{RF}=1900\text{MHz(CW)}$, $T_a=+25^\circ\text{C}$
 $P_{RF}=\text{Const. (ICC1}=240\text{mA}@V_{CC}=3.3\text{V, } P_{out}=+23.2\text{dBm})$
 $V_{CC}=3.3\text{V}$, $V_{CTL1}=2.7\text{V}$
 $V_{CTL2}=V_{LNA}=V_{MIX}=V_{LO}=0\text{V}$

■ TYPICAL CHARACTERISTICS (High Power Mode, TX: PA + ANT SW SECTION)

Phm vs. V_{BB} Terminal Voltage

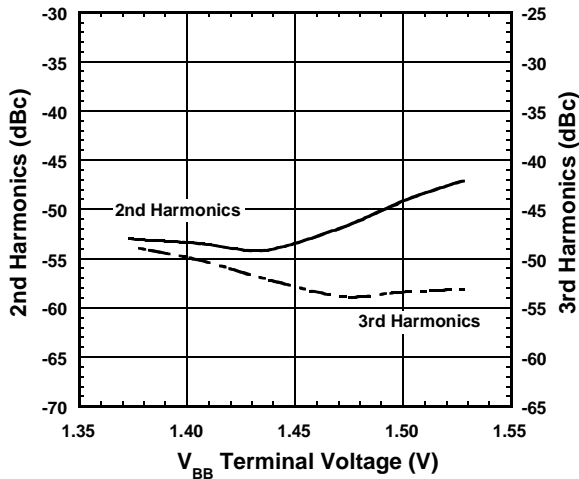

Condition
 $f_{RF}=1900\text{MHz(CW)}$, $T_a=+25^\circ\text{C}$
 $P_{RF}=\text{Const. (ICC1=240mA@V_{CC}=3.3V, P_{out}=+23.2\text{dBm})}$
 $V_{CC}=3.3\text{V}$, $V_{CTL1}=2.7\text{V}$
 $V_{CTL2}=V_{LNA}=V_{MIX}=V_{LO}=0\text{V}$

OBW vs. V_{BB} Terminal Voltage

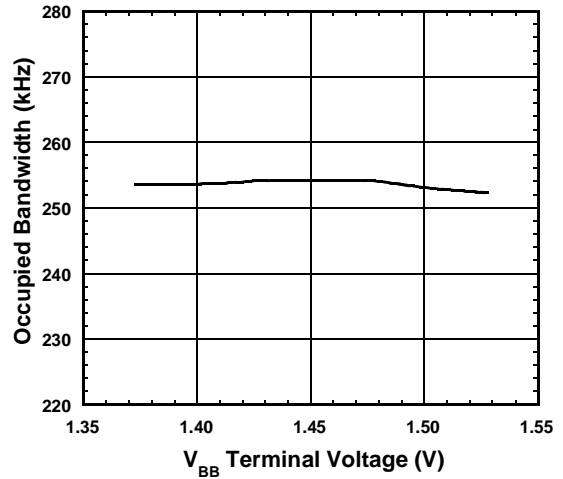

Condition
 $f_{RF}=1900\text{MHz}(\pi/4\text{DQPSK})$, $T_a=+25^\circ\text{C}$
 $P_{RF}=\text{Const. (ICC1=240mA@V_{CC}=3.3V, P_{out}=+23.2\text{dBm})}$
 $V_{CC}=3.3\text{V}$, $V_{CTL1}=2.7\text{V}$
 $V_{CTL2}=V_{LNA}=V_{MIX}=V_{LO}=0\text{V}$

Gp, Output Power vs. V_{CC} Terminal Voltage

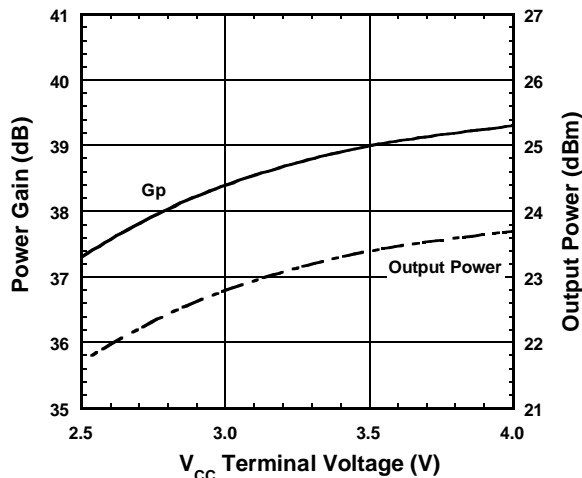

Condition
 $f_{RF}=1900\text{MHz(CW)}$, $T_a=+25^\circ\text{C}$
 $P_{RF}=\text{Const. (ICC1=240mA@V_{CC}=3.3V, P_{out}=+23.2\text{dBm})}$
 $V_{BB1}=\text{Const. (ICC1=240mA@V_{CC}=3.3V, P_{out}=+23.2\text{dBm})}$
 $V_{CTL1}=2.7\text{V}$, $V_{CTL2}=V_{LNA}=V_{MIX}=V_{LO}=0\text{V}$

ACPR1, ACPR2 vs. V_{CC} Terminal Voltage

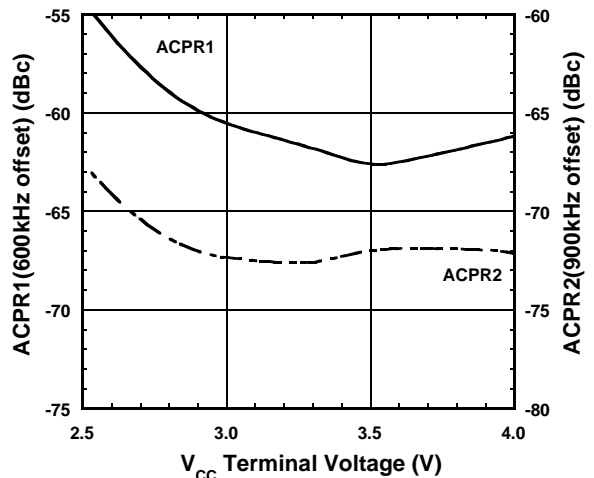

Condition
 $f_{RF}=1900\text{MHz}(\pi/4\text{DQPSK})$, $T_a=+25^\circ\text{C}$
 $P_{RF}=\text{Const. (ICC1=240mA@V_{CC}=3.3V, P_{out}=+23.2\text{dBm})}$
 $V_{BB1}=\text{Const. (ICC1=240mA@V_{CC}=3.3V, P_{out}=+23.2\text{dBm})}$
 $V_{CTL1}=2.7\text{V}$, $V_{CTL2}=V_{LNA}=V_{MIX}=V_{LO}=0\text{V}$

NJG1723KT2

■ TYPICAL CHARACTERISTICS (High Power Mode, TX: PA + ANT SW SECTION)

Idle, I_{BB} vs. V_{CC} Terminal Voltage

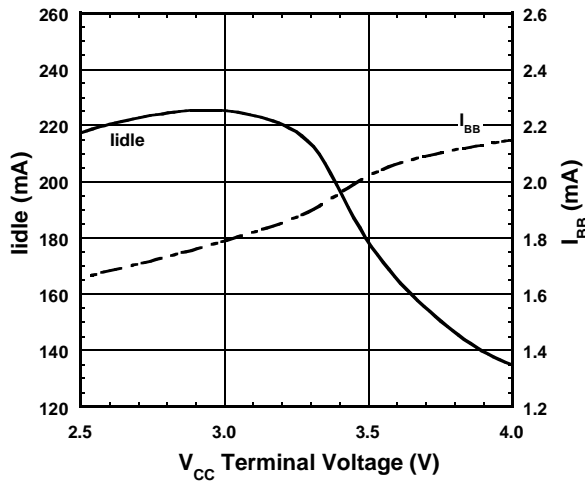

Condition
 $T_a = +25^\circ\text{C}$
 $V_{BB1} = \text{Const.}$ ($ICC1 = 240\text{mA}$ @ $V_{CC} = 3.3\text{V}$, $P_{out} = +23.2\text{dBm}$)
 $V_{CTL1} = 2.7\text{V}$, $V_{CTL2} = V_{LNA} = V_{MIX} = V_{LO} = 0\text{V}$

ICC, I_{BB} vs. V_{CC} Terminal Voltage

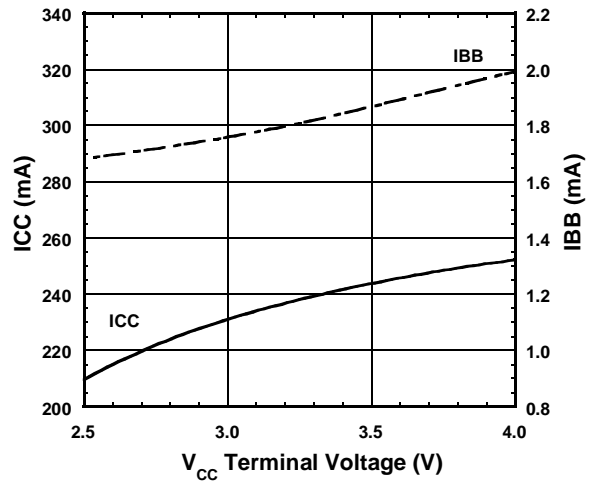

Condition
 $f_{RF} = 1900\text{MHz (CW)}$, $T_a = +25^\circ\text{C}$
 $P_{RF} = \text{Const.}$ ($ICC1 = 240\text{mA}$ @ $V_{CC} = 3.3\text{V}$, $P_{out} = +23.2\text{dBm}$)
 $V_{BB1} = \text{Const.}$ ($ICC1 = 240\text{mA}$ @ $V_{CC} = 3.3\text{V}$, $P_{out} = +23.2\text{dBm}$)
 $V_{CTL1} = 2.7\text{V}$, $V_{CTL2} = V_{LNA} = V_{MIX} = V_{LO} = 0\text{V}$

Phm vs. V_{CC} Terminal Voltage

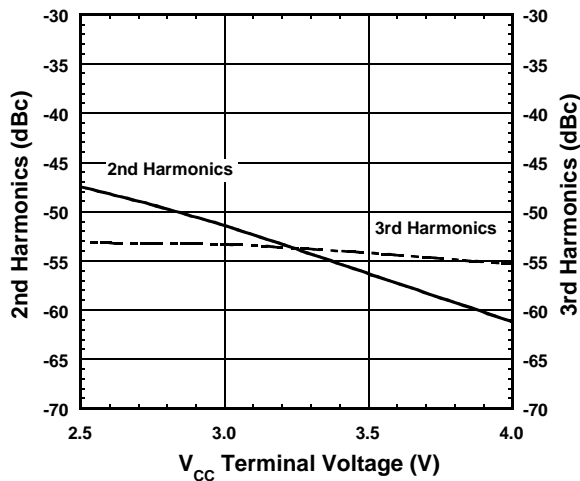

Condition
 $f_{RF} = 1900\text{MHz (CW)}$, $T_a = +25^\circ\text{C}$
 $P_{RF} = \text{Const.}$ ($ICC1 = 240\text{mA}$ @ $V_{CC} = 3.3\text{V}$, $P_{out} = +23.2\text{dBm}$)
 $V_{BB1} = \text{Const.}$ ($ICC1 = 240\text{mA}$ @ $V_{CC} = 3.3\text{V}$, $P_{out} = +23.2\text{dBm}$)
 $V_{CTL1} = 2.7\text{V}$, $V_{CTL2} = V_{LNA} = V_{MIX} = V_{LO} = 0\text{V}$

OBW vs. V_{CC} Terminal Voltage

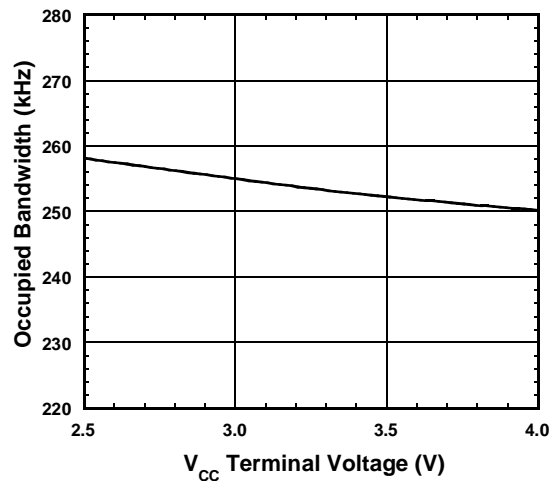

Condition
 $f_{RF} = 1900\text{MHz } (\pi/4\text{DQPSK})$, $T_a = +25^\circ\text{C}$
 $P_{RF} = \text{Const.}$ ($ICC1 = 240\text{mA}$ @ $V_{CC} = 3.3\text{V}$, $P_{out} = +23.2\text{dBm}$)
 $V_{BB1} = \text{Const.}$ ($ICC1 = 240\text{mA}$ @ $V_{CC} = 3.3\text{V}$, $P_{out} = +23.2\text{dBm}$)
 $V_{CTL1} = 2.7\text{V}$, $V_{CTL2} = V_{LNA} = V_{MIX} = V_{LO} = 0\text{V}$

■ TYPICAL CHARACTERISTICS (High Power Mode, TX: PA + ANT SW SECTION)

Gp, P_{-1dB} vs. Temperature

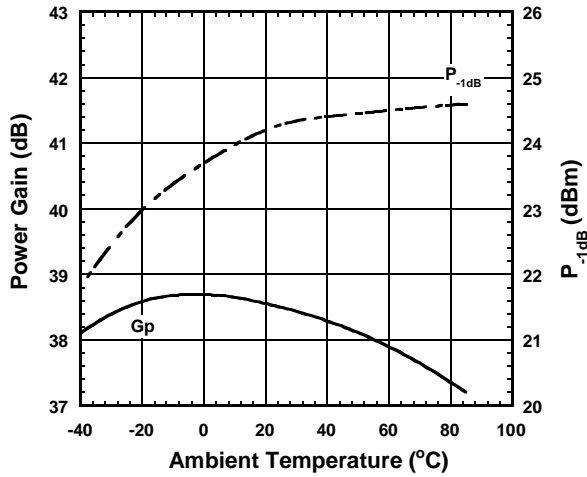

Condition
 $f_{RF}=1900\text{MHz(CW)}$, $P_{OUT}=+23.2\text{dBm}$
 $V_{BB1}=\text{Const. (@ICC1=240mA, Ta}=+25^{\circ}\text{C)}$
 $V_{CC}=3.3\text{V}$, $V_{CTL1}=2.7\text{V}$,
 $V_{CTL2}=V_{LNA}=V_{MIX}=V_{LO}=0\text{V}$

ACPR1, ACPR2 vs. Temperature

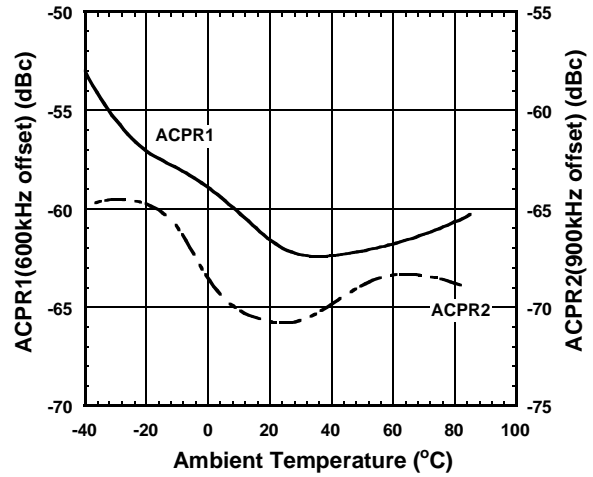

Condition
 $f_{RF}=1900\text{MHz}(\pi/4\text{DQPSK})$, $P_{OUT}=+23.2\text{dBm}$
 $V_{BB1}=\text{Const. (@ICC1=240mA, Ta}=+25^{\circ}\text{C)}$
 $V_{CC}=3.3\text{V}$, $V_{CTL1}=2.7\text{V}$,
 $V_{CTL2}=V_{LNA}=V_{MIX}=V_{LO}=0\text{V}$

ICC, IBB vs. Temperature

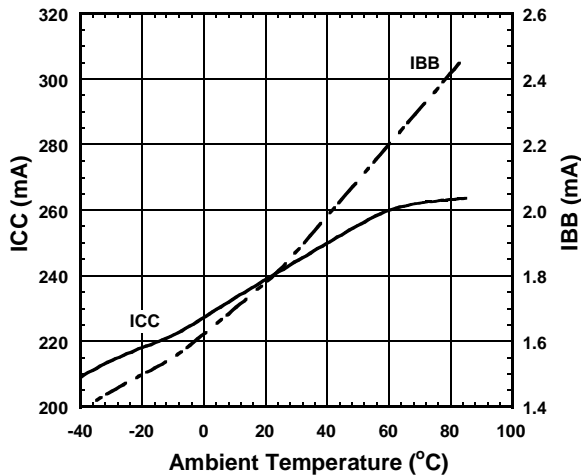

Condition
 $f_{RF}=1900\text{MHz(CW)}$, $P_{OUT}=+23.2\text{dBm}$
 $V_{BB1}=\text{Const. (@ICC1=240mA, Ta}=+25^{\circ}\text{C)}$
 $V_{CC}=3.3\text{V}$, $V_{CTL1}=2.7\text{V}$,
 $V_{CTL2}=V_{LNA}=V_{MIX}=V_{LO}=0\text{V}$

Phm vs. Temperature

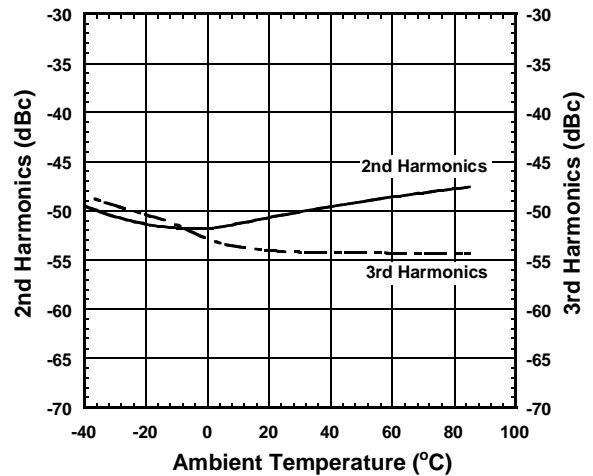

Condition
 $f_{RF}=1900\text{MHz(CW)}$, $P_{OUT}=+23.2\text{dBm}$
 $V_{BB1}=\text{Const. (@ICC1=240mA, Ta}=+25^{\circ}\text{C)}$
 $V_{CC}=3.3\text{V}$, $V_{CTL1}=2.7\text{V}$,
 $V_{CTL2}=V_{LNA}=V_{MIX}=V_{LO}=0\text{V}$

NJG1723KT2

■ TYPICAL CHARACTERISTICS (High Power Mode, TX: PA + ANT SW SECTION)

OBW vs. Temperature

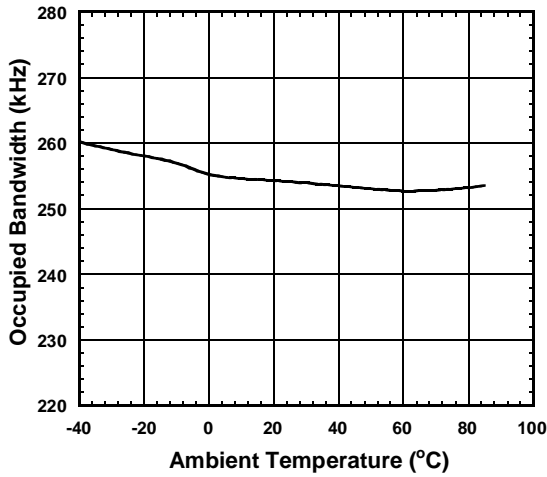

Condition
 $f_{RF}=1900\text{MHz}(\pi/4\text{DQPSK})$, $P_{OUT}=+23.2\text{dBm}$
 $V_{BB1}=\text{Const.} (@\text{ICC1}=240\text{mA}, T_a=+25^\circ\text{C})$
 $V_{CC}=3.3\text{V}$, $V_{CTL1}=2.7\text{V}$,
 $V_{CTL2}=V_{LNA}=V_{MIX}=V_{LO}=0\text{V}$

Idle, I_{BB} vs. Temperature

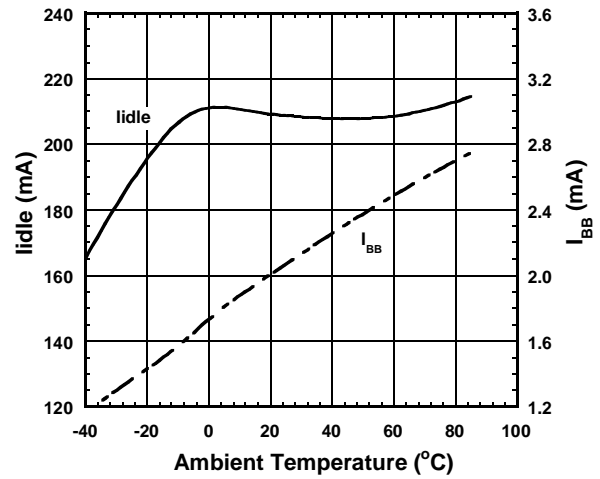

Condition
 $V_{BB1}=\text{Const.} (@\text{ICC1}=240\text{mA}, T_a=+25^\circ\text{C})$
 $V_{CC}=3.3\text{V}$, $V_{CTL1}=2.7\text{V}$,
 $V_{CTL2}=V_{LNA}=V_{MIX}=V_{LO}=0\text{V}$

G_p , Output Power vs. Temperature

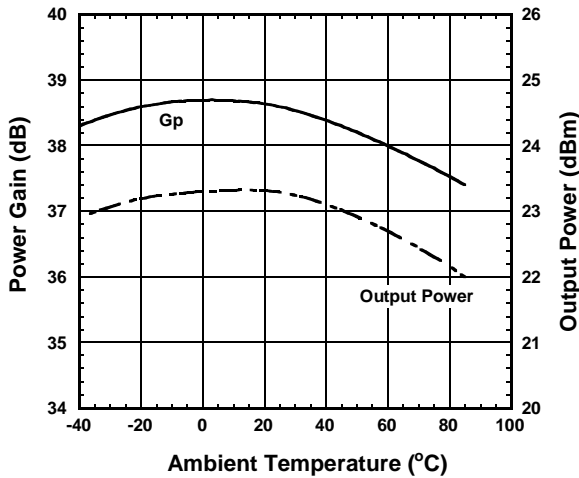

Condition
 $f_{RF}=1900\text{MHz}(\text{CW})$
 $P_{RF}=\text{Const.} (\text{ICC1}=240\text{mA} @ V_{CC}=3.3\text{V}, P_{out}=+23.2\text{dBm})$
 $V_{BB1}=\text{Const.} (\text{ICC1}=240\text{mA} @ V_{CC}=3.3\text{V}, P_{out}=+23.2\text{dBm})$
 $V_{CC}=3.3\text{V}$, $V_{CTL1}=2.7\text{V}$,
 $V_{CTL2}=V_{LNA}=V_{MIX}=V_{LO}=0\text{V}$

ACPR1, ACPR2 vs. Temperature

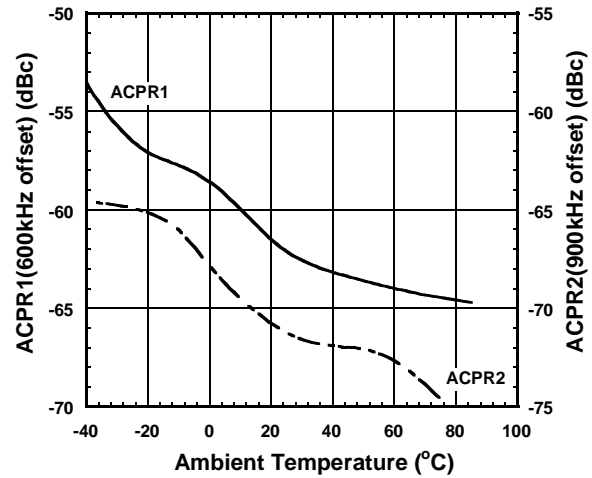

Condition
 $f_{RF}=1900\text{MHz}(\pi/4\text{DQPSK})$
 $P_{RF}=\text{Const.} (\text{ICC1}=240\text{mA} @ V_{CC}=3.3\text{V}, P_{out}=+23.2\text{dBm})$
 $V_{BB1}=\text{Const.} (\text{ICC1}=240\text{mA} @ V_{CC}=3.3\text{V}, P_{out}=+23.2\text{dBm})$
 $V_{CC}=3.3\text{V}$, $V_{CTL1}=2.7\text{V}$,
 $V_{CTL2}=V_{LNA}=V_{MIX}=V_{LO}=0\text{V}$

■ TYPICAL CHARACTERISTICS (High Power Mode, TX: PA + ANT SW SECTION)

ICC, IBB vs. Temperature

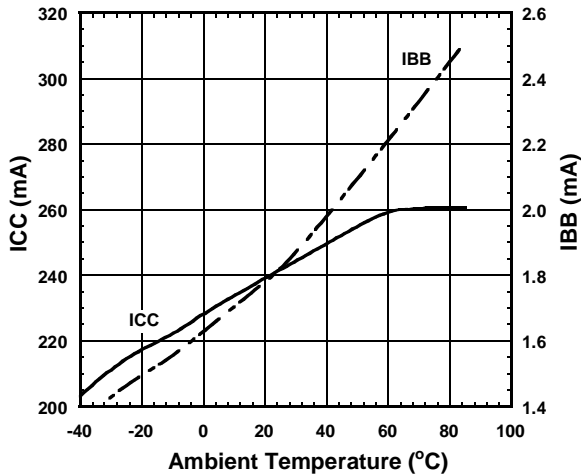

Condition
 $f_{RF}=1900\text{MHz(CW)}$
 $P_{RF}=\text{Const. (ICC1=240mA@V}_{CC}=3.3\text{V, Pout=+23.2dBm)}$
 $V_{BB1}=\text{Const. (ICC1=240mA@V}_{CC}=3.3\text{V, Pout=+23.2dBm)}$
 $V_{CC}=3.3\text{V, V}_{CTL1}=2.7\text{V,}$
 $V_{CTL2}=V_{LNA}=V_{MIX}=V_{LO}=0\text{V}$

Phm vs. Temperature

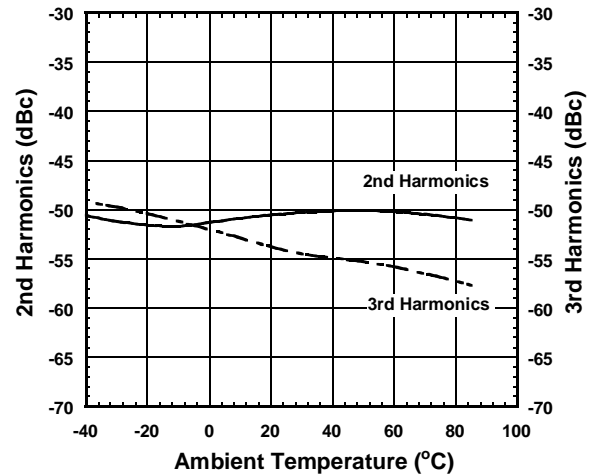

Condition
 $f_{RF}=1900\text{MHz(CW)}$
 $P_{RF}=\text{Const. (ICC1=240mA@V}_{CC}=3.3\text{V, Pout=+23.2dBm)}$
 $V_{BB1}=\text{Const. (ICC1=240mA@V}_{CC}=3.3\text{V, Pout=+23.2dBm)}$
 $V_{CC}=3.3\text{V, V}_{CTL1}=2.7\text{V,}$
 $V_{CTL2}=V_{LNA}=V_{MIX}=V_{LO}=0\text{V}$

OBW vs. Temperature

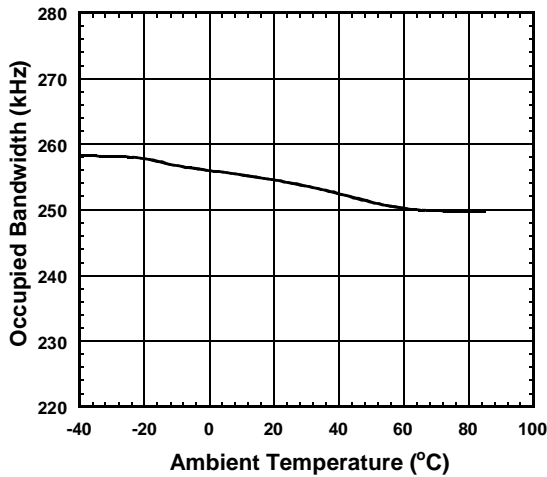

Condition
 $f_{RF}=1900\text{MHz}(\pi/4\text{DQPSK})$
 $P_{RF}=\text{Const. (ICC1=240mA@V}_{CC}=3.3\text{V, Pout=+23.2dBm)}$
 $V_{BB1}=\text{Const. (ICC1=240mA@V}_{CC}=3.3\text{V, Pout=+23.2dBm)}$
 $V_{CC}=3.3\text{V, V}_{CTL1}=2.7\text{V,}$
 $V_{CTL2}=V_{LNA}=V_{MIX}=V_{LO}=0\text{V}$

PA IN to ANT K factor vs. Frequency Temperature Response

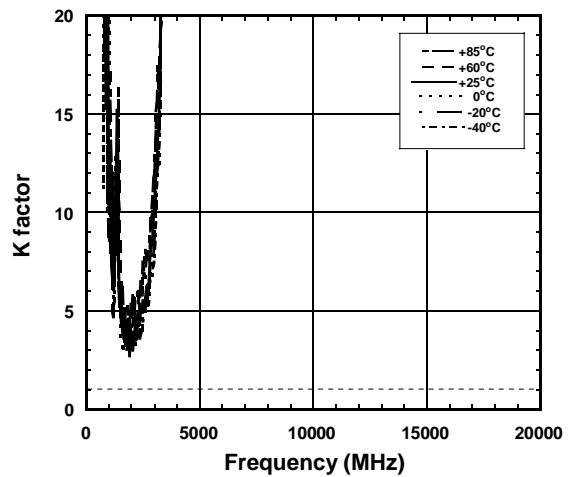

Condition
 $f_{RF}=1900\text{MHz(CW)}$
 $T_a=-40\sim+85\text{ }^\circ\text{C}$
 $V_{BB1}=\text{Const. (@ICC1=240mA, T}_a=+25^\circ\text{C)}$
 $V_{CC}=3.3\text{V, V}_{CTL1}=2.7\text{V,}$
 $V_{CTL2}=V_{LNA}=V_{MIX}=V_{LO}=0\text{V}$

NJG1723KT2

■ TYPICAL CHARACTERISTICS (Low Power Mode, TX: PA + ANT SW SECTION)

Output Power, Gp vs. Input Power

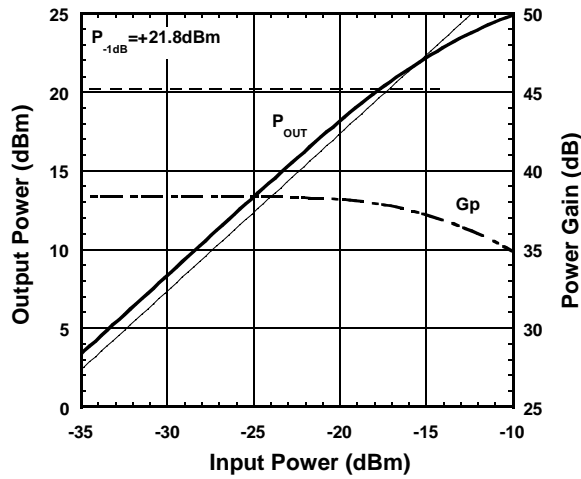

Condition
 $f_{RF}=1900\text{MHz(CW)}$, $T_a=+25^\circ\text{C}$
 $V_{BB2}=\text{Const. (@ICC2=180mA, Pout=+20.2dBm)}$
 $V_{CC}=3.3\text{V}$, $V_{CTL1}=2.7\text{V}$
 $V_{CTL2}=V_{LNA}=V_{MIX}=V_{LO}=0\text{V}$

Output Power, ACPR vs. Input Power

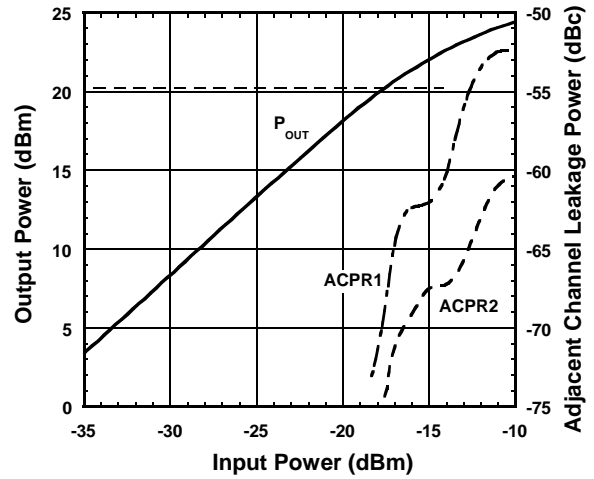

Condition
 $f_{RF}=1900\text{MHz}(\pi/4\text{DQPSK})$, $T_a=+25^\circ\text{C}$
 $V_{BB2}=\text{Const. (@ICC2=180mA, Pout=+20.2dBm)}$
 $V_{CC}=3.3\text{V}$, $V_{CTL1}=2.7\text{V}$
 $V_{CTL2}=V_{LNA}=V_{MIX}=V_{LO}=0\text{V}$

Output Power, ICC vs. Input Power

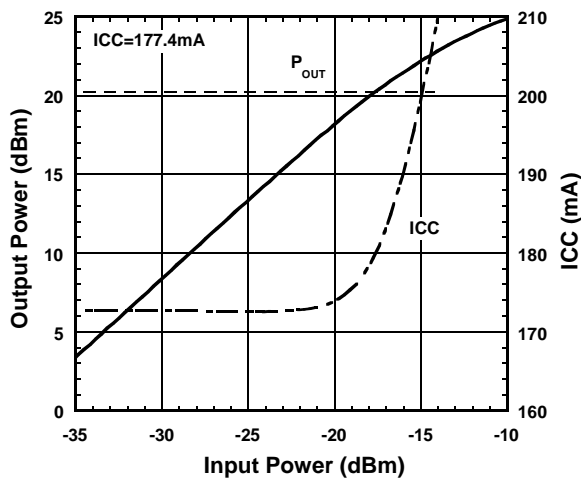

Condition
 $f_{RF}=1900\text{MHz(CW)}$, $T_a=+25^\circ\text{C}$
 $V_{BB2}=\text{Const. (@ICC2=180mA, Pout=+20.2dBm)}$
 $V_{CC}=3.3\text{V}$, $V_{CTL1}=2.7\text{V}$
 $V_{CTL2}=V_{LNA}=V_{MIX}=V_{LO}=0\text{V}$

Output Power, PAE vs. Input Power

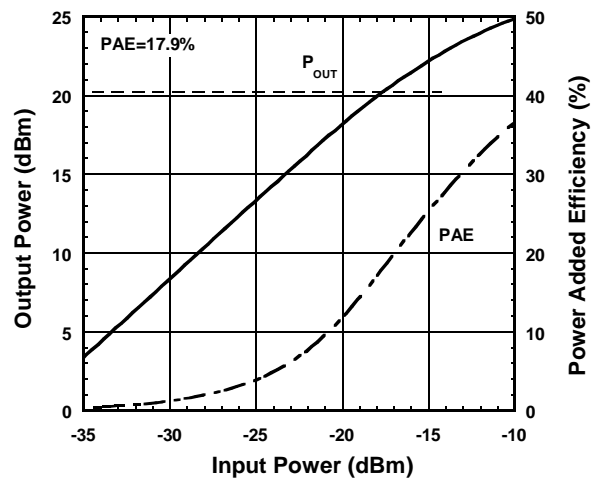

Condition
 $f_{RF}=1900\text{MHz(CW)}$, $T_a=+25^\circ\text{C}$
 $V_{BB2}=\text{Const. (@ICC2=180mA, Pout=+20.2dBm)}$
 $V_{CC}=3.3\text{V}$, $V_{CTL1}=2.7\text{V}$
 $V_{CTL2}=V_{LNA}=V_{MIX}=V_{LO}=0\text{V}$

■ TYPICAL CHARACTERISTICS (Low Power Mode, TX: PA + ANT SW SECTION)

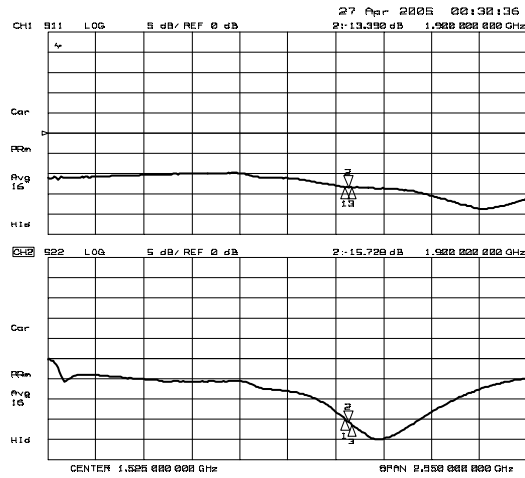

Condition
 Ta=+25°C
 V_{BB2}=Const. (@ICC2=180mA, Pout=+20.2dBm)
 V_{CC}=3.3V, V_{CTL1}=2.7V
 V_{CTL2}=V_{LNA}=V_{MIX}=V_{LO}=0V

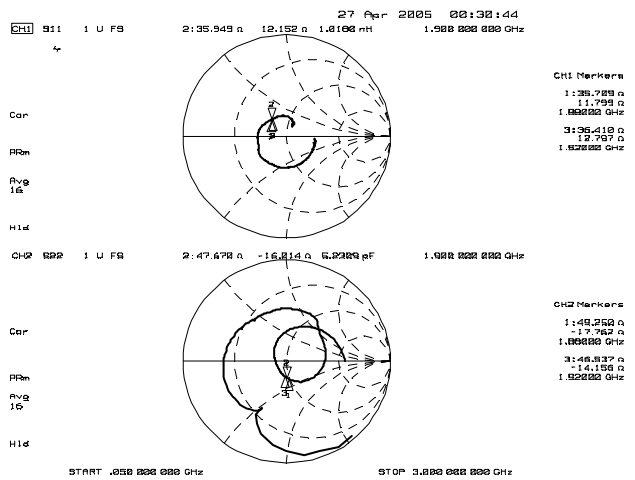

Condition
 Ta=+25°C
 V_{BB2}=Const. (@ICC2=180mA, Pout=+20.2dBm)
 V_{CC}=3.3V, V_{CTL1}=2.7V
 V_{CTL2}=V_{LNA}=V_{MIX}=V_{LO}=0V

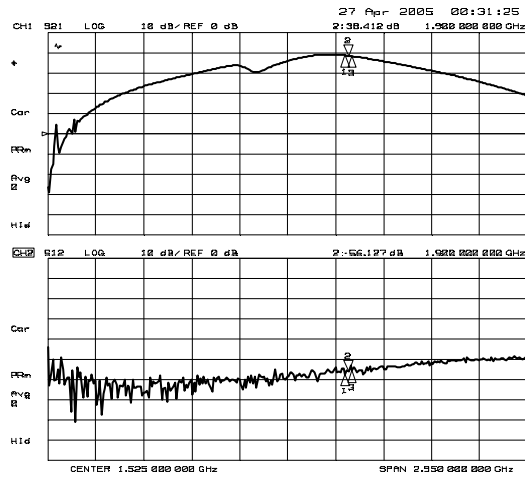

Condition
 Ta=+25°C
 V_{BB2}=Const. (@ICC2=180mA, Pout=+20.2dBm)
 V_{CC}=3.3V, V_{CTL1}=2.7V
 V_{CTL2}=V_{LNA}=V_{MIX}=V_{LO}=0V

NJG1723KT2

■ TYPICAL CHARACTERISTICS (Low Power Mode, TX: PA + ANT SW SECTION)

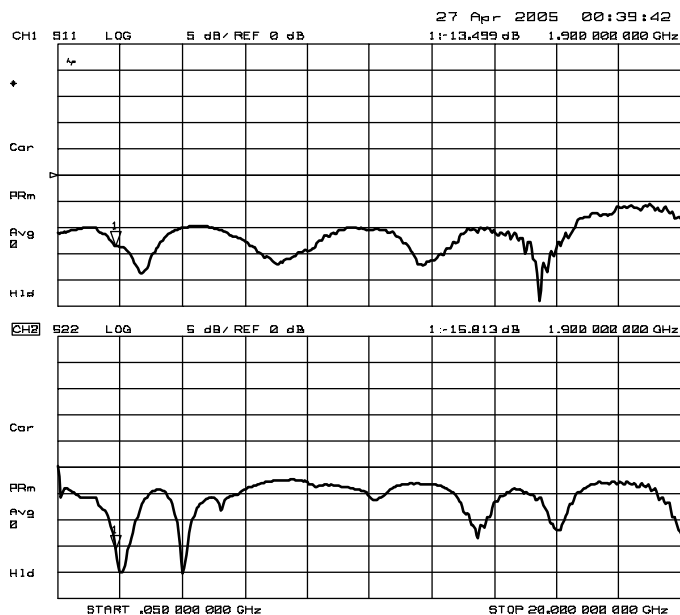

Condition
 $T_a = +25^\circ\text{C}$
 $V_{BB2} = \text{Const.} (@\text{ICC2} = 180\text{mA}, \text{Pout} = +20.2\text{dBm})$
 $V_{CC} = 3.3\text{V}, V_{CTL1} = 2.7\text{V}$
 $V_{CTL2} = V_{LNA} = V_{MIX} = V_{LO} = 0\text{V}$

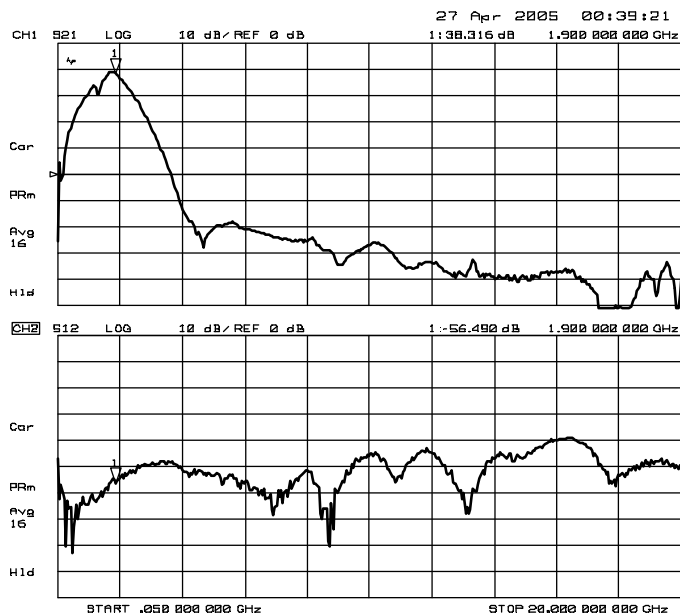

Condition
 $T_a = +25^\circ\text{C}$
 $V_{BB2} = \text{Const.} (@\text{ICC2} = 180\text{mA}, \text{Pout} = +20.2\text{dBm})$
 $V_{CC} = 3.3\text{V}, V_{CTL1} = 2.7\text{V}$
 $V_{CTL2} = V_{LNA} = V_{MIX} = V_{LO} = 0\text{V}$

■ TYPICAL CHARACTERISTICS (Low Power Mode, TX: PA + ANT SW SECTION)

Gp, P_{-1dB} vs. V_{BB} Terminal Voltage

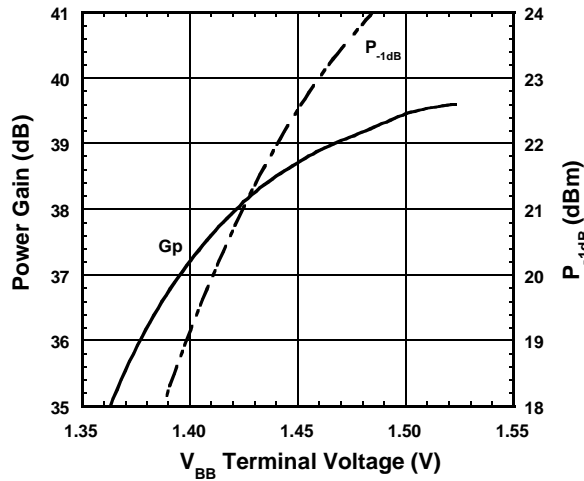

Condition
 $f_{RF}=1900\text{MHz(CW)}$, $T_a=+25^\circ\text{C}$
 $P_{RF}=\text{Const. (ICC2=180mA@V_{CC}=3.3V, P_{out}=+20.2\text{dBm})}$
 $V_{CC}=3.3\text{V}$, $V_{CTL1}=2.7\text{V}$
 $V_{CTL2}=V_{LNA}=V_{MIX}=V_{LO}=0\text{V}$

ACPR1, ACPR2 vs. V_{BB} Terminal Voltage

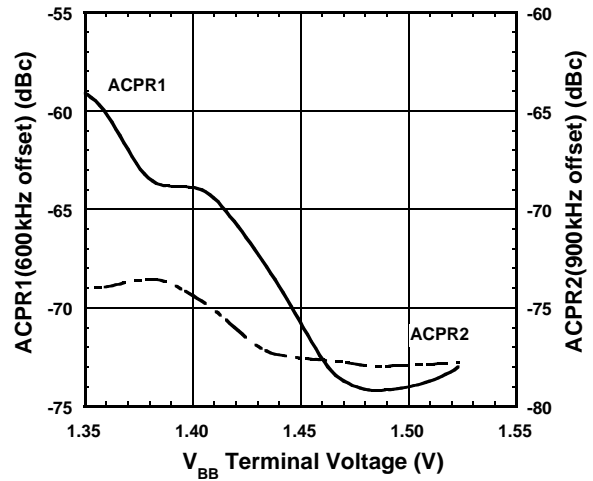

Condition
 $f_{RF}=1900\text{MHz}(\pi/4\text{DQPSK})$, $T_a=+25^\circ\text{C}$
 $P_{RF}=\text{Const. (ICC2=180mA@V_{CC}=3.3V, P_{out}=+20.2\text{dBm})}$
 $V_{CC}=3.3\text{V}$, $V_{CTL1}=2.7\text{V}$
 $V_{CTL2}=V_{LNA}=V_{MIX}=V_{LO}=0\text{V}$

Iidle, I_{BB} vs. V_{BB} Terminal Voltage

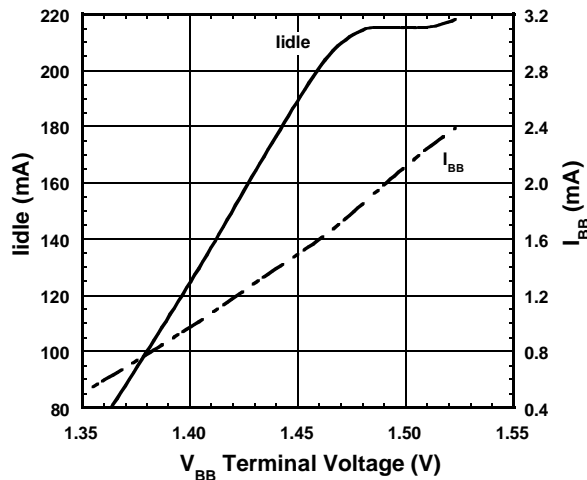

Condition
 $T_a=+25^\circ\text{C}$
 $V_{CC}=3.3\text{V}$, $V_{CTL1}=2.7\text{V}$
 $V_{CTL2}=V_{LNA}=V_{MIX}=V_{LO}=0\text{V}$

ICC, IBB vs. V_{BB} Terminal Voltage

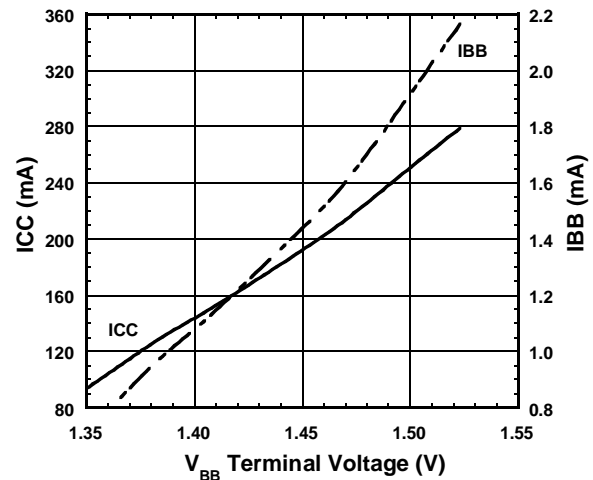

Condition
 $f_{RF}=1900\text{MHz(CW)}$, $T_a=+25^\circ\text{C}$
 $P_{RF}=\text{Const. (ICC2=180mA@V_{CC}=3.3V, P_{out}=+20.2\text{dBm})}$
 $V_{CC}=3.3\text{V}$, $V_{CTL1}=2.7\text{V}$
 $V_{CTL2}=V_{LNA}=V_{MIX}=V_{LO}=0\text{V}$

NJG1723KT2

■ TYPICAL CHARACTERISTICS (Low Power Mode, TX: PA + ANT SW SECTION)

Phm vs. V_{BB} Terminal Voltage

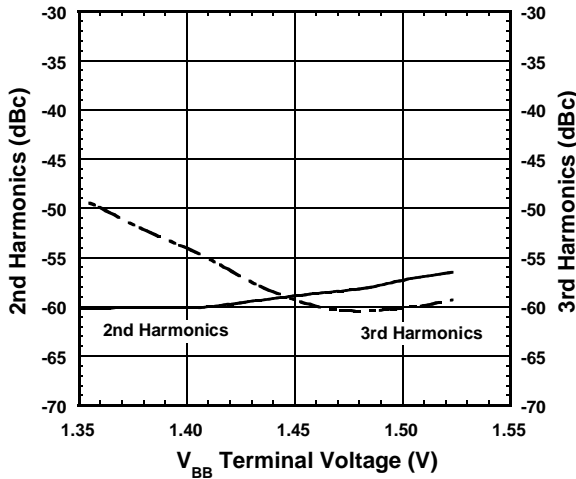

Condition
 $f_{RF}=1900\text{MHz(CW)}$, $T_a=+25^\circ\text{C}$
 $P_{RF}=\text{Const. (ICC2=180mA@V_{CC}=3.3V, P_{out}=+20.2\text{dBm})}$
 $V_{CC}=3.3\text{V}$, $V_{CTL1}=2.7\text{V}$
 $V_{CTL2}=V_{LNA}=V_{MIX}=V_{LO}=0\text{V}$

OBW vs. V_{BB} Terminal Voltage

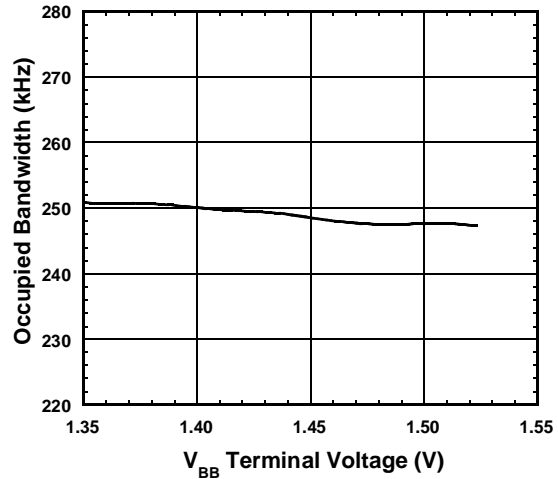

Condition
 $f_{RF}=1900\text{MHz}(\pi/4\text{DQPSK})$, $T_a=+25^\circ\text{C}$
 $P_{RF}=\text{Const. (ICC2=180mA@V_{CC}=3.3V, P_{out}=+20.2\text{dBm})}$
 $V_{CC}=3.3\text{V}$, $V_{CTL1}=2.7\text{V}$
 $V_{CTL2}=V_{LNA}=V_{MIX}=V_{LO}=0\text{V}$

G_p , Output Power vs. V_{CC} Terminal Voltage

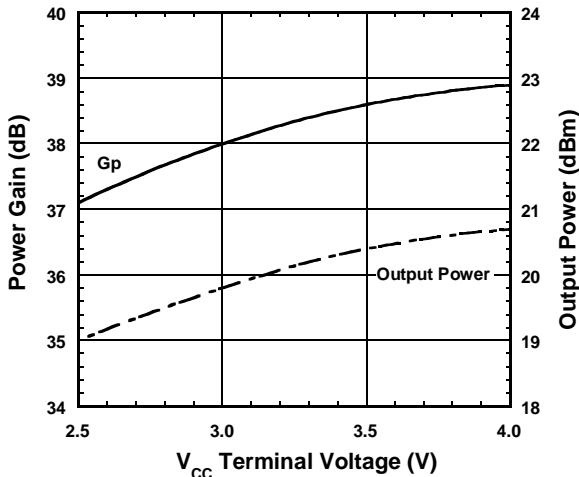

Condition
 $f_{RF}=1900\text{MHz(CW)}$, $T_a=+25^\circ\text{C}$
 $P_{RF}=\text{Const. (ICC2=180mA@V_{CC}=3.3V, P_{out}=+20.2\text{dBm})}$
 $V_{BB2}=\text{Const. (ICC2=180mA@V_{CC}=3.3V, P_{out}=+20.2\text{dBm})}$
 $V_{CTL1}=2.7\text{V}$, $V_{CTL2}=V_{LNA}=V_{MIX}=V_{LO}=0\text{V}$

ACPR1, ACPR2 vs. V_{CC} Terminal Voltage

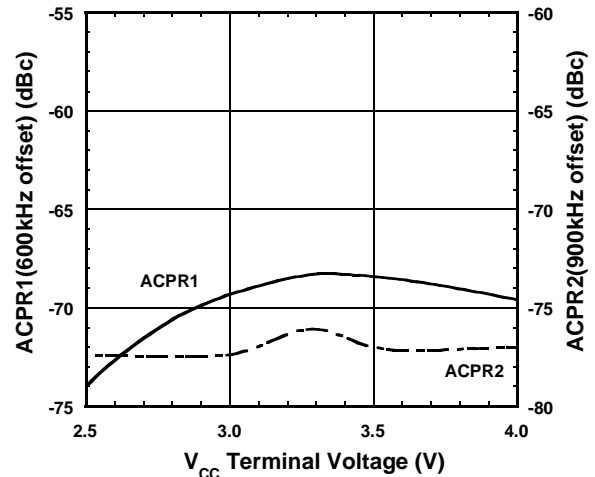

Condition
 $f_{RF}=1900\text{MHz}(\pi/4\text{DQPSK})$, $T_a=+25^\circ\text{C}$
 $P_{RF}=\text{Const. (ICC2=180mA@V_{CC}=3.3V, P_{out}=+20.2\text{dBm})}$
 $V_{BB2}=\text{Const. (ICC2=180mA@V_{CC}=3.3V, P_{out}=+20.2\text{dBm})}$
 $V_{CTL1}=2.7\text{V}$, $V_{CTL2}=V_{LNA}=V_{MIX}=V_{LO}=0\text{V}$

■ TYPICAL CHARACTERISTICS (Low Power Mode, TX: PA + ANT SW SECTION)

Idle, I_{BB} vs. V_{CC} Terminal Voltage

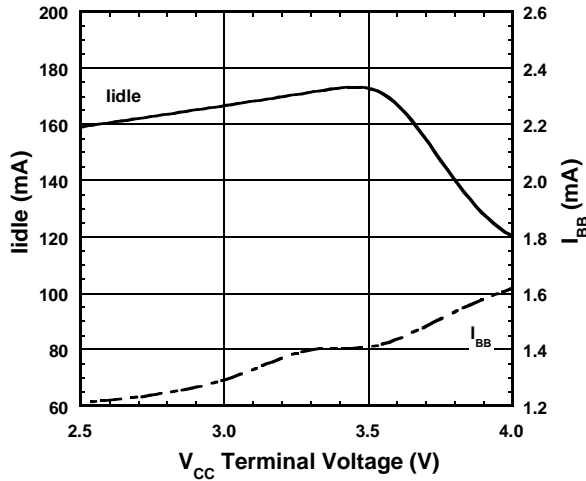

Condition
 $T_a = +25^\circ\text{C}$
 $V_{BB2} = \text{Const. (ICC2} = 180\text{mA@}V_{CC} = 3.3\text{V, } P_{\text{out}} = +20.2\text{dBm)}$
 $V_{CTL1} = 2.7\text{V, } V_{CTL2} = V_{LNA} = V_{MIX} = V_{LO} = 0\text{V}$

ICC, I_{BB} vs. V_{CC} Terminal Voltage

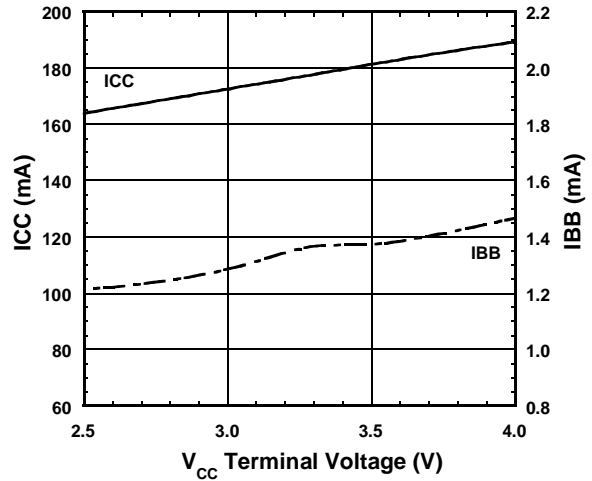

Condition
 $f_{RF} = 1900\text{MHz(CW), } T_a = +25^\circ\text{C}$
 $P_{RF} = \text{Const. (ICC2} = 180\text{mA@}V_{CC} = 3.3\text{V, } P_{\text{out}} = +20.2\text{dBm)}$
 $V_{BB2} = \text{Const. (ICC2} = 180\text{mA@}V_{CC} = 3.3\text{V, } P_{\text{out}} = +20.2\text{dBm)}$
 $V_{CTL1} = 2.7\text{V, } V_{CTL2} = V_{LNA} = V_{MIX} = V_{LO} = 0\text{V}$

Phm vs. V_{CC} Terminal Voltage

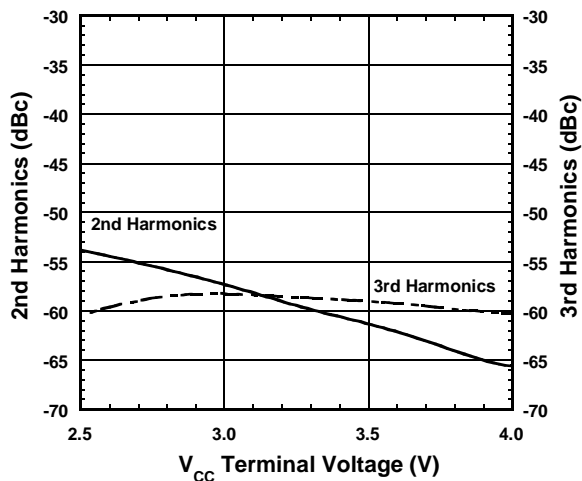

Condition
 $f_{RF} = 1900\text{MHz(CW), } T_a = +25^\circ\text{C}$
 $P_{RF} = \text{Const. (ICC2} = 180\text{mA@}V_{CC} = 3.3\text{V, } P_{\text{out}} = +20.2\text{dBm)}$
 $V_{BB2} = \text{Const. (ICC2} = 180\text{mA@}V_{CC} = 3.3\text{V, } P_{\text{out}} = +20.2\text{dBm)}$
 $V_{CTL1} = 2.7\text{V, } V_{CTL2} = V_{LNA} = V_{MIX} = V_{LO} = 0\text{V}$

OBW vs. V_{CC} Terminal Voltage

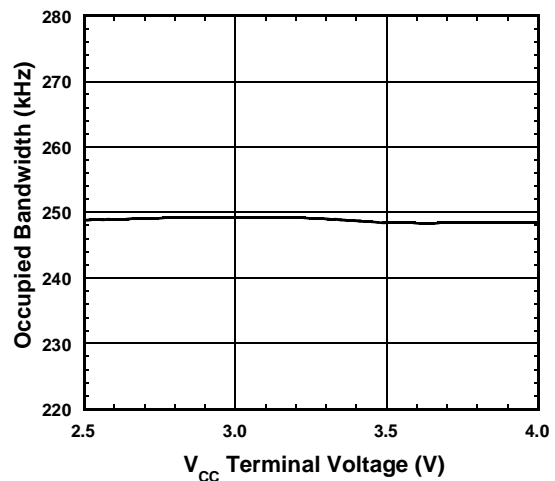

Condition
 $f_{RF} = 1900\text{MHz}(\pi/4\text{DQPSK}), T_a = +25^\circ\text{C}$
 $P_{RF} = \text{Const. (ICC2} = 180\text{mA@}V_{CC} = 3.3\text{V, } P_{\text{out}} = +20.2\text{dBm)}$
 $V_{BB2} = \text{Const. (ICC2} = 180\text{mA@}V_{CC} = 3.3\text{V, } P_{\text{out}} = +20.2\text{dBm)}$
 $V_{CTL1} = 2.7\text{V, } V_{CTL2} = V_{LNA} = V_{MIX} = V_{LO} = 0\text{V}$

NJG1723KT2

■ TYPICAL CHARACTERISTICS (Low Power Mode, TX: PA + ANT SW SECTION)

Gp, P_{-1dB} vs. Temperature

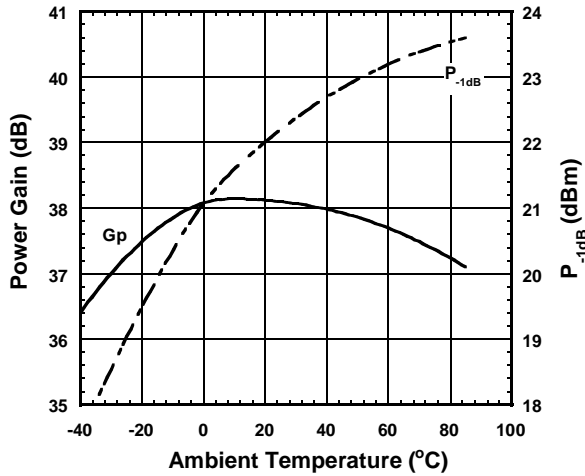

Condition
 $f_{RF}=1900\text{MHz(CW)}$, $P_{OUT}=+20.2\text{dBm}$
 $V_{BB2}=\text{Const. (@ICC2=180mA, Ta=+25}^\circ\text{C)}$
 $V_{CC}=3.3\text{V}$, $V_{CTL1}=2.7\text{V}$,
 $V_{CTL2}=V_{LNA}=V_{MIX}=V_{LO}=0\text{V}$

ACPR1, ACPR2 vs. Temperature

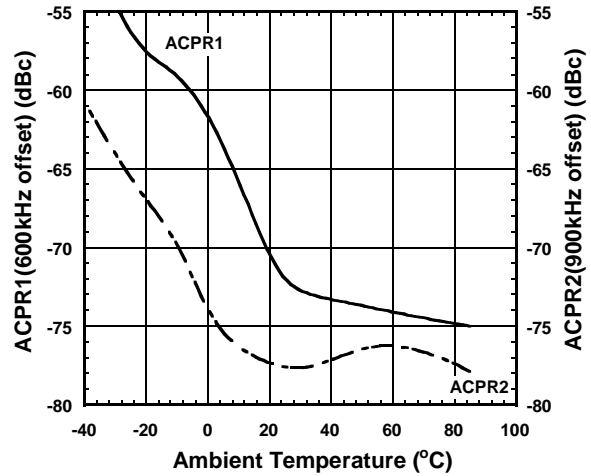

Condition
 $f_{RF}=1900\text{MHz}(\pi/4\text{DQPSK})$, $P_{OUT}=+20.2\text{dBm}$
 $V_{BB2}=\text{Const. (@ICC2=180mA, Ta=+25}^\circ\text{C)}$
 $V_{CC}=3.3\text{V}$, $V_{CTL1}=2.7\text{V}$,
 $V_{CTL2}=V_{LNA}=V_{MIX}=V_{LO}=0\text{V}$

ICC, IBB vs. Temperature

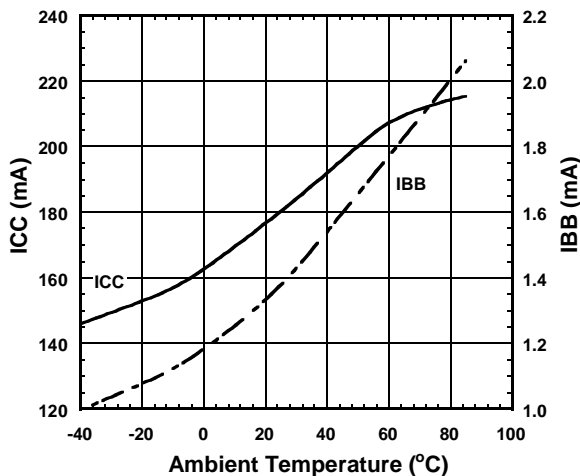

Condition
 $f_{RF}=1900\text{MHz(CW)}$, $P_{OUT}=+20.2\text{dBm}$
 $V_{BB2}=\text{Const. (@ICC2=180mA, Ta=+25}^\circ\text{C)}$
 $V_{CC}=3.3\text{V}$, $V_{CTL1}=2.7\text{V}$,
 $V_{CTL2}=V_{LNA}=V_{MIX}=V_{LO}=0\text{V}$

Phm vs. Temperature

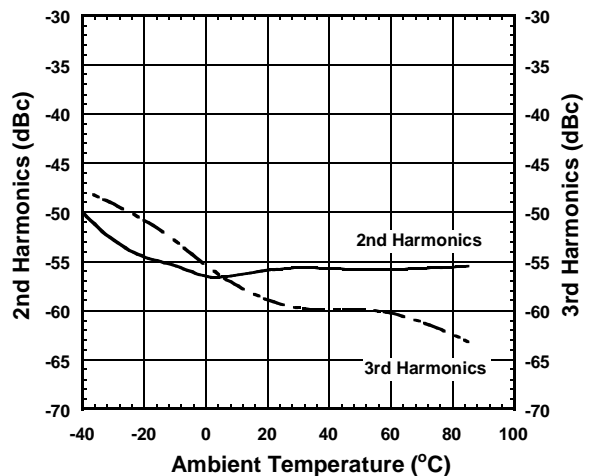

Condition
 $f_{RF}=1900\text{MHz(CW)}$, $P_{OUT}=+20.2\text{dBm}$
 $V_{BB2}=\text{Const. (@ICC2=180mA, Ta=+25}^\circ\text{C)}$
 $V_{CC}=3.3\text{V}$, $V_{CTL1}=2.7\text{V}$,
 $V_{CTL2}=V_{LNA}=V_{MIX}=V_{LO}=0\text{V}$

■ TYPICAL CHARACTERISTICS (Low Power Mode, TX: PA + ANT SW SECTION)

OBW vs. Temperature

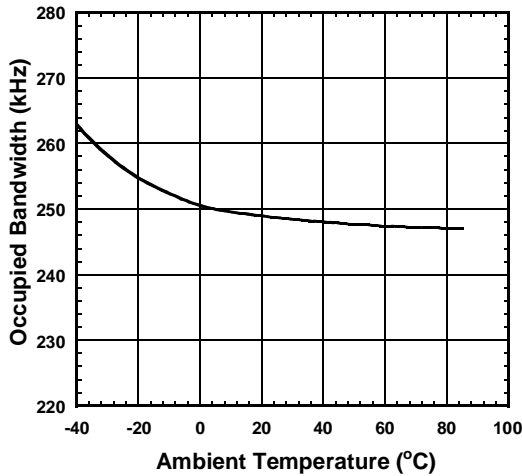

Condition
 $f_{RF}=1900\text{MHz}(\pi/4\text{DQPSK})$, $P_{OUT}=+20.2\text{dBm}$
 $V_{BB2}=\text{Const.} (@\text{ICC2}=180\text{mA}, T_a=+25^\circ\text{C})$
 $V_{CC}=3.3\text{V}$, $V_{CTL1}=2.7\text{V}$,
 $V_{CTL2}=V_{LNA}=V_{MIX}=V_{LO}=0\text{V}$

Idle, I_{BB} vs. Temperature

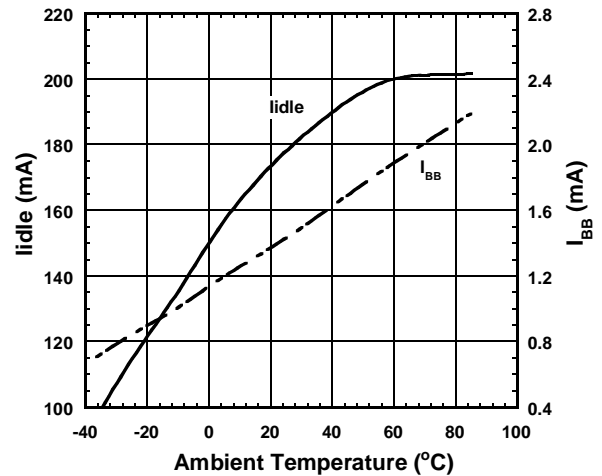

Condition
 $V_{BB2}=\text{Const.} (@\text{ICC2}=180\text{mA}, T_a=+25^\circ\text{C})$
 $V_{CC}=3.3\text{V}$, $V_{CTL1}=2.7\text{V}$,
 $V_{CTL2}=V_{LNA}=V_{MIX}=V_{LO}=0\text{V}$

G_p , Output Power vs. Temperature

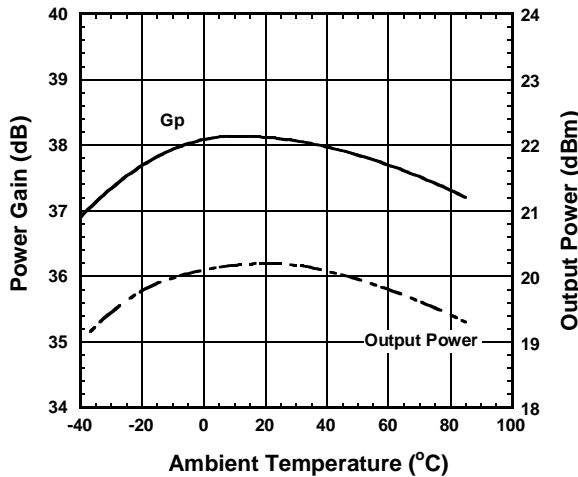

Condition
 $f_{RF}=1900\text{MHz}(\text{CW})$
 $P_{RF}=\text{Const.} (\text{ICC2}=180\text{mA} @ V_{CC}=3.3\text{V}, P_{out}=+20.2\text{dBm})$
 $V_{BB2}=\text{Const.} (\text{ICC2}=180\text{mA} @ V_{CC}=3.3\text{V}, P_{out}=+20.2\text{dBm})$
 $V_{CC}=3.3\text{V}$, $V_{CTL1}=2.7\text{V}$,
 $V_{CTL2}=V_{LNA}=V_{MIX}=V_{LO}=0\text{V}$

ACPR1, ACPR2 vs. Temperature

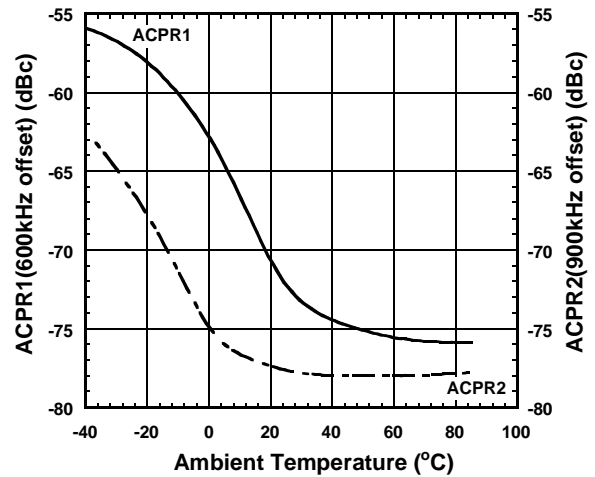

Condition
 $f_{RF}=1900\text{MHz}(\pi/4\text{DQPSK})$
 $P_{RF}=\text{Const.} (\text{ICC2}=180\text{mA} @ V_{CC}=3.3\text{V}, P_{out}=+20.2\text{dBm})$
 $V_{BB2}=\text{Const.} (\text{ICC2}=180\text{mA} @ V_{CC}=3.3\text{V}, P_{out}=+20.2\text{dBm})$
 $V_{CC}=3.3\text{V}$, $V_{CTL1}=2.7\text{V}$,
 $V_{CTL2}=V_{LNA}=V_{MIX}=V_{LO}=0\text{V}$

NJG1723KT2

■ TYPICAL CHARACTERISTICS (Low Power Mode, TX: PA + ANT SW SECTION)

ICC, IBB vs. Temperature

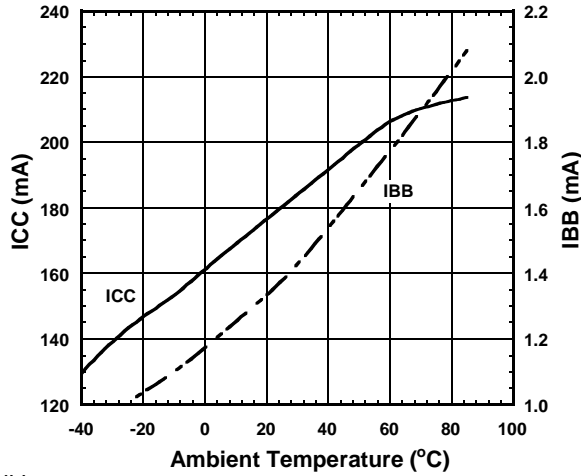

Condition
 $f_{RF}=1900\text{MHz(CW)}$
 $P_{RF}=\text{Const. (ICC2=180mA@V_{CC}=3.3V, P_{out}=+20.2\text{dBm})}$
 $V_{BB2}=\text{Const. (ICC2=180mA@V_{CC}=3.3V, P_{out}=+20.2\text{dBm})}$
 $V_{CC}=3.3V, V_{CTL1}=2.7V,$
 $V_{CTL2}=V_{LNA}=V_{MIX}=V_{LO}=0V$

Phm vs. Temperature

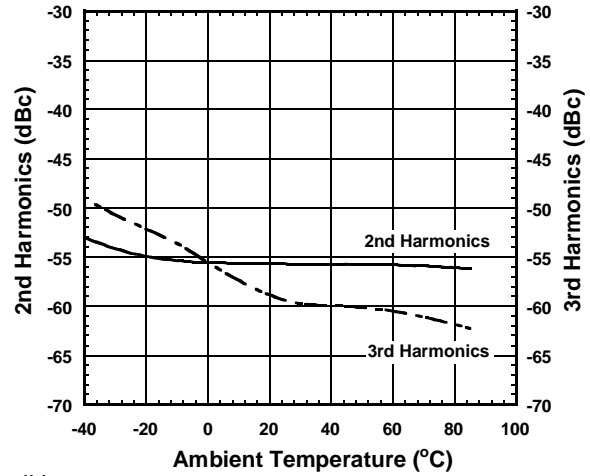

Condition
 $f_{RF}=1900\text{MHz(CW)}$
 $P_{RF}=\text{Const. (ICC2=180mA@V_{CC}=3.3V, P_{out}=+20.2\text{dBm})}$
 $V_{BB2}=\text{Const. (ICC2=180mA@V_{CC}=3.3V, P_{out}=+20.2\text{dBm})}$
 $V_{CC}=3.3V, V_{CTL1}=2.7V,$
 $V_{CTL2}=V_{LNA}=V_{MIX}=V_{LO}=0V$

OBW vs. Temperature

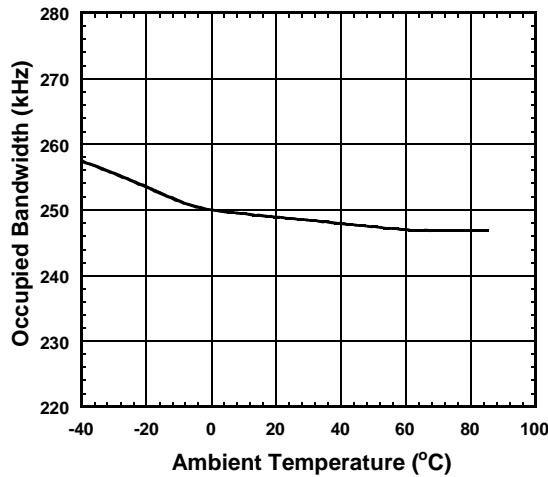

Condition
 $f_{RF}=1900\text{MHz}(\pi/4\text{DQPSK})$
 $P_{RF}=\text{Const. (ICC2=180mA@V_{CC}=3.3V, P_{out}=+20.2\text{dBm})}$
 $V_{BB2}=\text{Const. (ICC2=180mA@V_{CC}=3.3V, P_{out}=+20.2\text{dBm})}$
 $V_{CC}=3.3V, V_{CTL1}=2.7V,$
 $V_{CTL2}=V_{LNA}=V_{MIX}=V_{LO}=0V$

PA IN to ANT K factor vs. Frequency Temperature Response

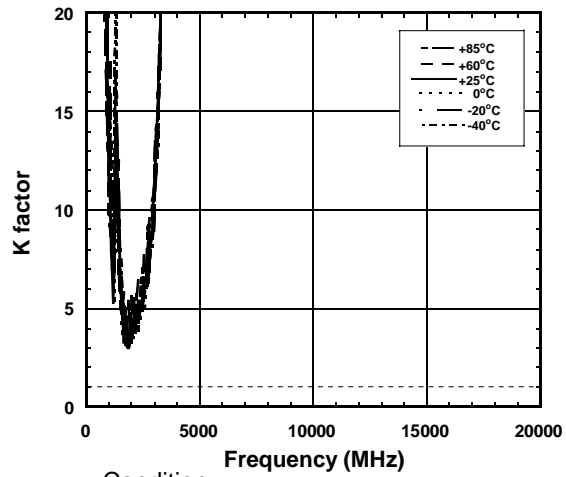

Condition
 $f_{RF}=1900\text{MHz(CW)}$
 $T_a=-40\sim+85\text{ }^\circ\text{C}$
 $V_{BB2}=\text{Const. (@ICC2=180mA, } T_a=+25\text{ }^\circ\text{C)}$
 $V_{CC}=3.3V, V_{CTL1}=2.7V,$
 $V_{CTL2}=V_{LNA}=V_{MIX}=V_{LO}=0V$

■ TYPICAL CHARACTERISTICS (RX: ANT SW + LNA + MIXER SECTION)

Gc, NF vs. RF Frequency

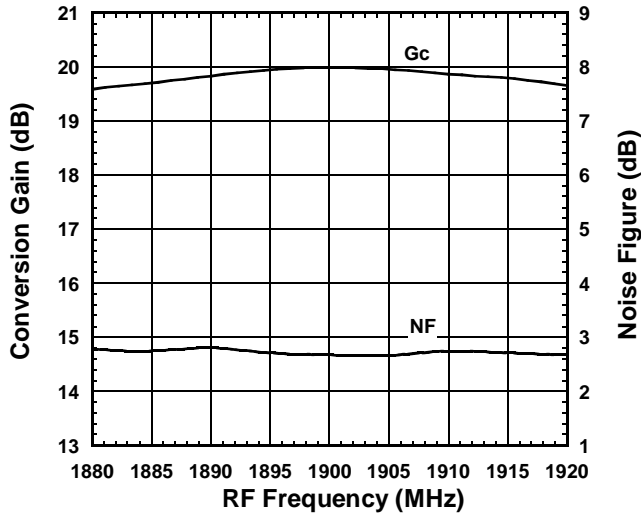

Condition
 $f_{IF}=240\text{MHz}$
 $f_{RF}=1880\sim 1920\text{MHz}$, $P_{RF}=-45\text{dBm}$
 Lower LOCAL, $P_{LO}=-15\text{dBm}$
 $V_{CTL1}=0\text{V}$, $V_{CTL2}=2.7\text{V}$
 $V_{LNA}=V_{MIX}=V_{LO}=2.7\text{V}$

Gc, NF vs. LO Power

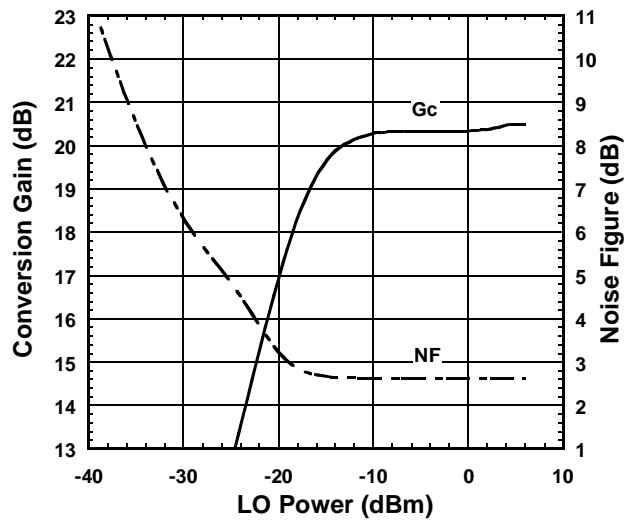

Condition
 $f_{IF}=240\text{MHz}$
 $f_{RF}=1900\text{MHz}$, $P_{RF}=-45\text{dBm}$
 $f_{LO}=1660\text{MHz}$
 $V_{CTL1}=0\text{V}$, $V_{CTL2}=2.7\text{V}$
 $V_{LNA}=V_{MIX}=V_{LO}=2.7\text{V}$

OIP3, IIP3 vs. RF Frequency

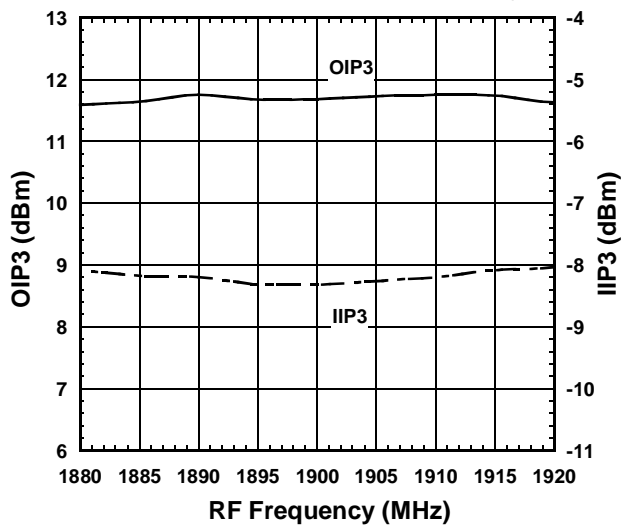

Condition
 $f_{IF}=240\text{MHz}$
 $f_{RF}=1880\sim 1920\text{MHz}$, $P_{RF}=-40\text{dBm}$
 $f_{RF\text{ OFFSET}}=600\text{kHz}$
 Lower LOCAL, $P_{LO}=-15\text{dBm}$
 $V_{CTL1}=0\text{V}$, $V_{CTL2}=2.7\text{V}$
 $V_{LNA}=V_{MIX}=V_{LO}=2.7\text{V}$

$$\text{OIP3}=(3\times\text{IF}-\text{IM3})/2$$

$$\text{IIP3}=\text{OIP3}-\text{Gc}$$

OIP3, IIP3 vs. LO Power

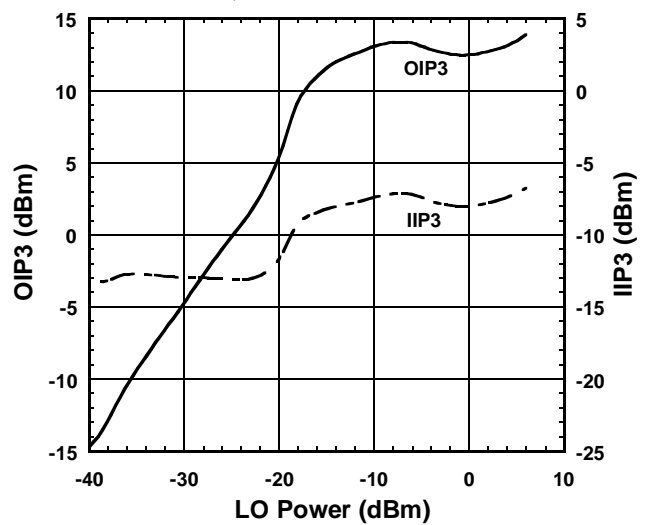

Condition
 $f_{IF}=240\text{MHz}$
 $f_{RF}=1900.0+1900.6\text{MHz}$, $P_{RF}=-40\text{dBm}$
 $f_{LO}=1660\text{MHz}$
 $V_{CTL1}=0\text{V}$, $V_{CTL2}=2.7\text{V}$
 $V_{LNA}=V_{MIX}=V_{LO}=2.7\text{V}$

NJG1723KT2

■ TYPICAL CHARACTERISTICS (RX: ANT SW + LNA + MIXER SECTION)

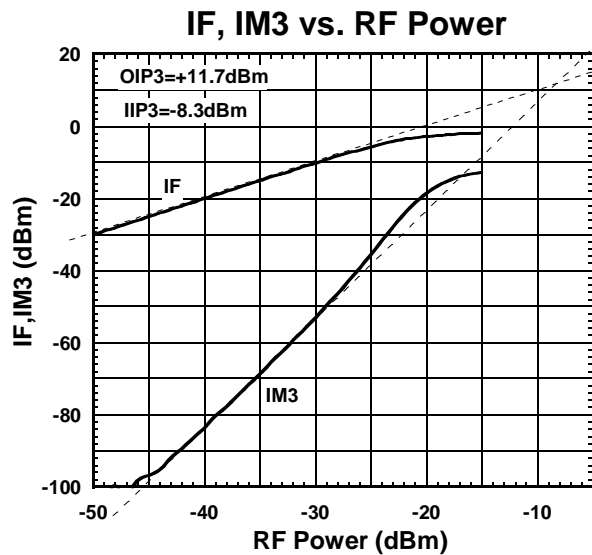

Condition
 $f_{IF}=240\text{MHz}$
 $f_{RF}=1900.0+1900.6\text{MHz}$
 $f_{LO}=1660\text{MHz}$, $P_{LO}=-15\text{dBm}$
 $V_{CTL1}=0\text{V}$, $V_{CTL2}=2.7\text{V}$
 $V_{LNA}=V_{MIX}=V_{LO}=2.7\text{V}$

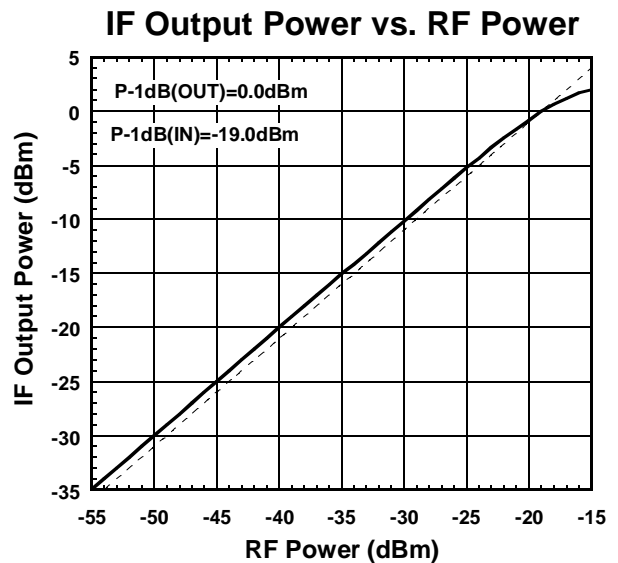

Condition
 $f_{IF}=240\text{MHz}$
 $f_{RF}=1900\text{MHz}$
 $f_{LO}=1660\text{MHz}$, $P_{LO}=-15\text{dBm}$
 $V_{CTL1}=0\text{V}$, $V_{CTL2}=2.7\text{V}$
 $V_{LNA}=V_{MIX}=V_{LO}=2.7\text{V}$

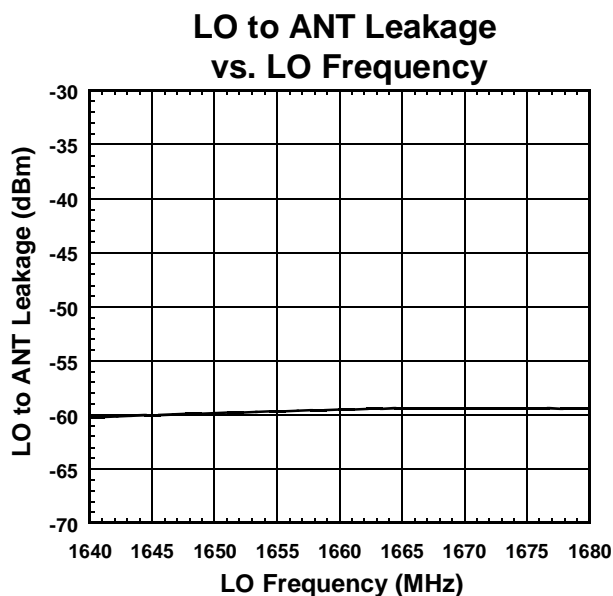

Condition
 IF OUT 50ohm term.
 $P_{LO}=-15\text{dBm}$
 $V_{CTL1}=0\text{V}$, $V_{CTL2}=2.7\text{V}$
 $V_{LNA}=V_{MIX}=V_{LO}=2.7\text{V}$

TYPICAL CHARACTERISTICS (RX: ANT SW + LNA + MIXER SECTION)

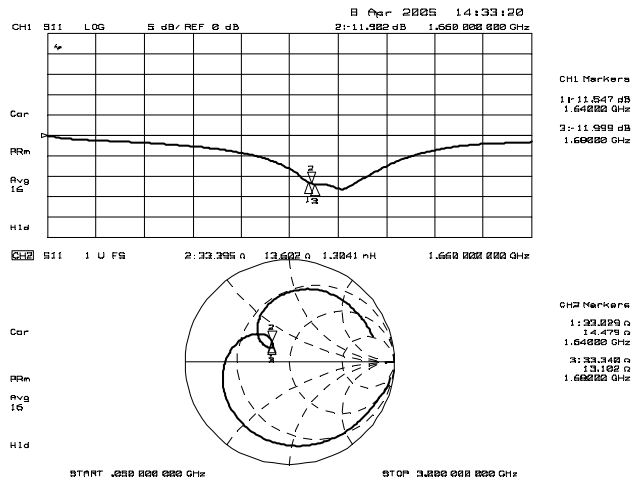
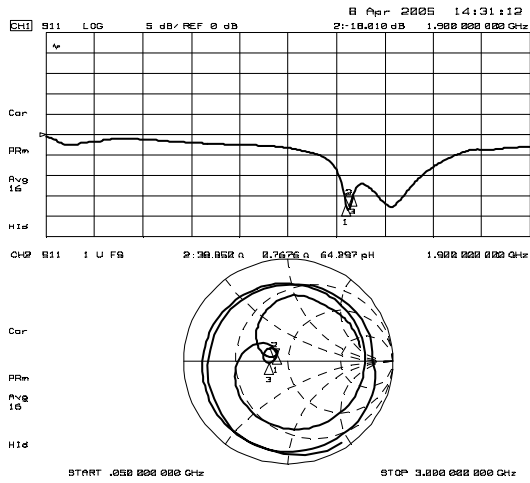

Condition
 $P_{LO} = -15\text{dBm}$
 IF OUT 50ohm term.
 $V_{CTL1} = 0\text{V}, V_{CTL2} = 2.7\text{V}$
 $V_{LNA} = V_{MIX} = V_{LO} = 2.7\text{V}$

Condition
 ANT, IF OUT 50ohm term.
 $V_{CTL1} = 0\text{V}, V_{CTL2} = 2.7\text{V}$
 $V_{LNA} = V_{MIX} = V_{LO} = 2.7\text{V}$

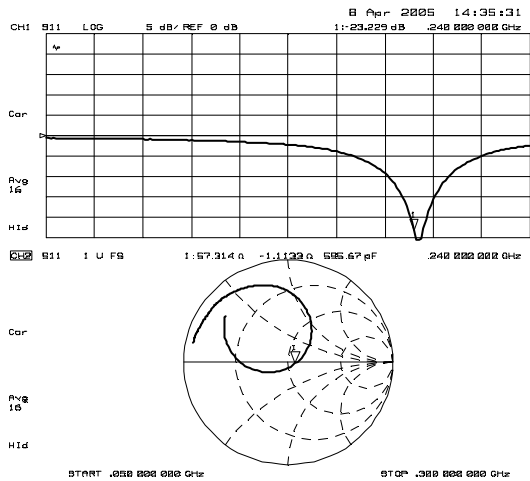

Condition
 $P_{LO} = -15\text{dBm}$
 ANT 50ohm term.
 $V_{CTL1} = 0\text{V}, V_{CTL2} = 2.7\text{V}$
 $V_{LNA} = V_{MIX} = V_{LO} = 2.7\text{V}$

NJG1723KT2

■ TYPICAL CHARACTERISTICS (RX: ANT SW + LNA + MIXER SECTION)

Conversion Gain, Noise Figure

vs. V_{LNA} , V_{MIX} , V_{LO}

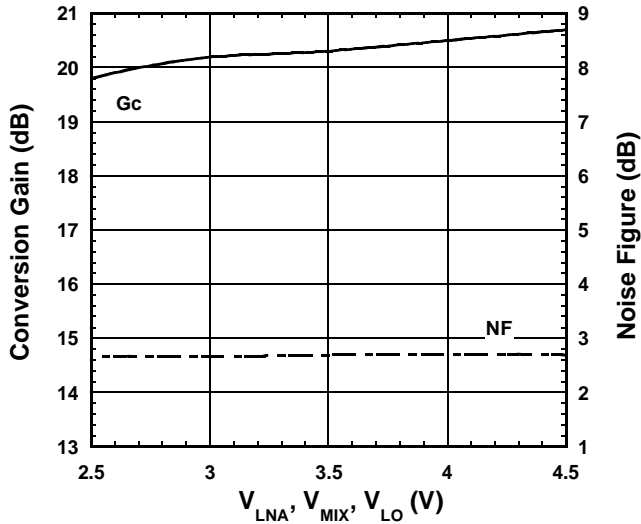

Condition
 $f_{IF}=240\text{MHz}$
 $f_{RF}=1900\text{MHz}$, $P_{RF}=-45\text{dBm}$
 $f_{LO}=1660\text{MHz}$, $P_{LO}=-15\text{dBm}$
 $V_{CTL1}=0\text{V}$

OIP3, IIP3 vs. V_{LNA} , V_{MIX} , V_{LO}

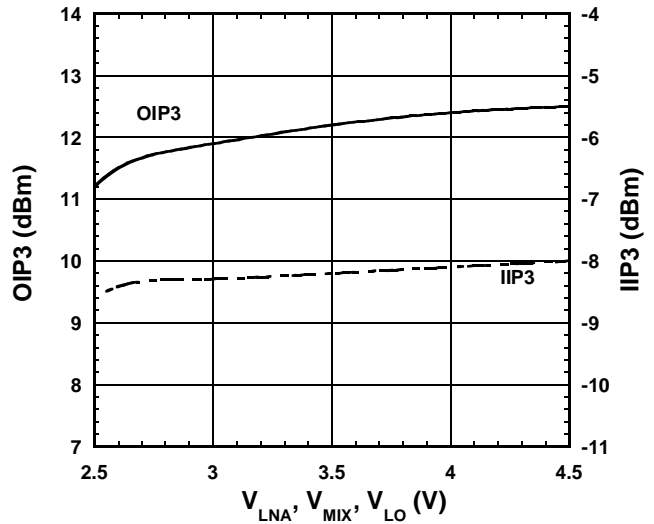

Condition
 $f_{IF}=240\text{MHz}$
 $f_{RF}=1900\text{MHz}$, $P_{RF}=-40\text{dBm}$
 $f_{LO}=1660\text{MHz}$, $P_{LO}=-15\text{dBm}$
 $V_{CTL1}=0\text{V}$

P-1dB vs. V_{LNA} , V_{MIX} , V_{LO}

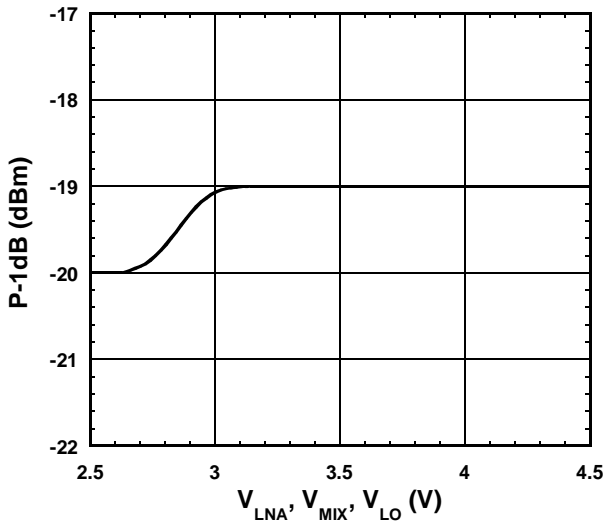

Condition
 $f_{IF}=240\text{MHz}$
 $f_{RF}=1900\text{MHz}$, $P_{RF}=-45\text{dBm}$
 $f_{LO}=1660\text{MHz}$, $P_{LO}=-15\text{dBm}$
 $V_{CTL1}=0\text{V}$

I_{LNA} , I_{MIX} , I_{LO} vs. V_{LNA} , V_{MIX} , V_{LO}

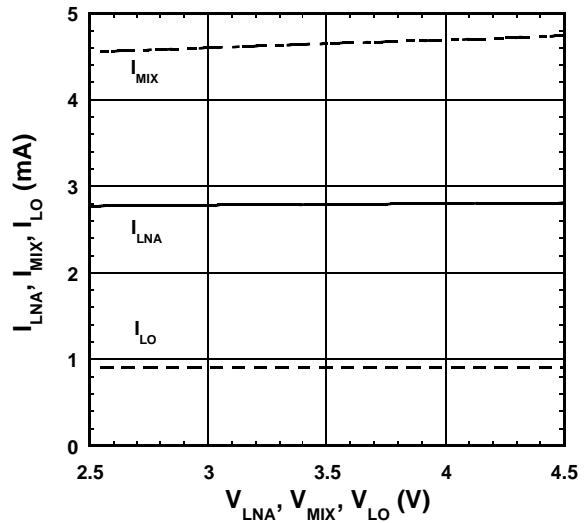

Condition
 $f_{IF}=240\text{MHz}$
 $f_{RF}=1900\text{MHz}$, $P_{RF}=-45\text{dBm}$
 $f_{LO}=1660\text{MHz}$, $P_{LO}=-15\text{dBm}$
 $V_{CTL1}=0\text{V}$

■ TYPICAL CHARACTERISTICS (RX: ANT SW + LNA + MIXER SECTION)

Conversion Gain vs. RF Frequency Temperature Responce

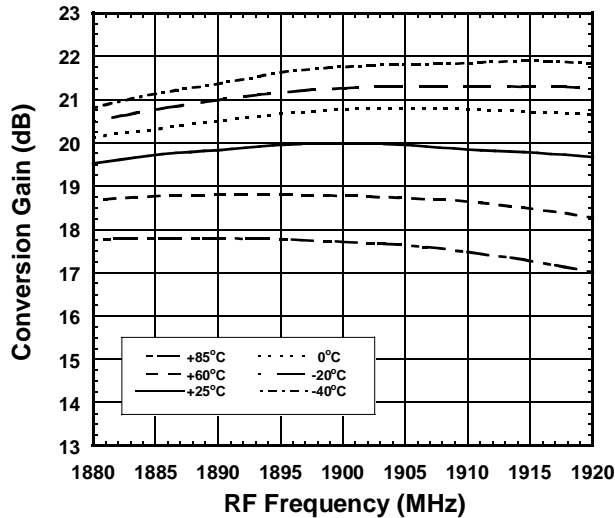

Condition
 $f_{IF}=240\text{MHz}$
 $f_{RF}=1880\sim 1920\text{MHz}, P_{RF}=-45\text{dBm}$
 Lower LOCAL, $P_{LO}=-15\text{dBm}$
 $V_{CTL1}=0\text{V}, V_{CTL2}=2.7\text{V}$
 $V_{LNA}=V_{MIX}=V_{LO}=2.7\text{V}$

Noise Figure vs. RF Frequency Temperature Responce

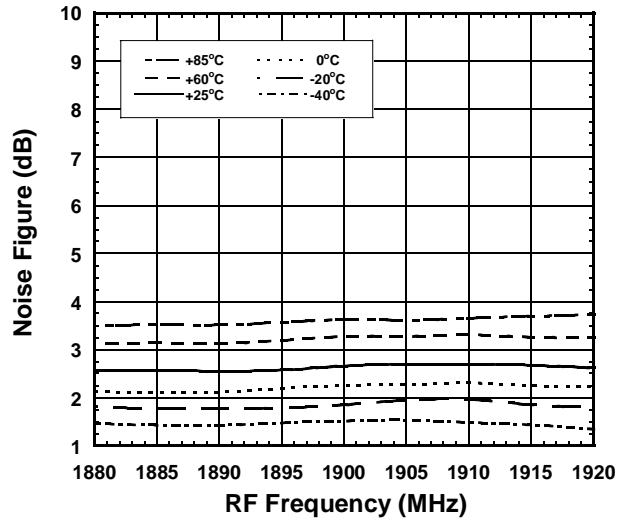

Condition
 $f_{IF}=240\text{MHz}$
 $f_{RF}=1880\sim 1920\text{MHz}$
 Lower LOCAL, $P_{LO}=-15\text{dBm}$
 $V_{CTL1}=0\text{V}, V_{CTL2}=2.7\text{V}$
 $V_{LNA}=V_{MIX}=V_{LO}=2.7\text{V}$

IIP3 vs. RF Frequency Temperature Responce

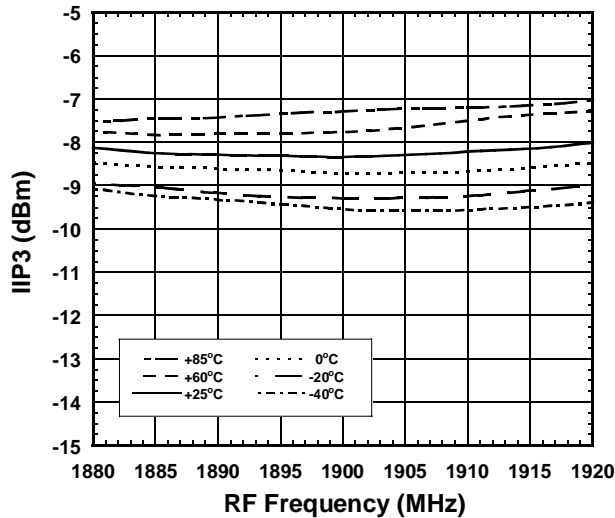

Condition
 $f_{IF}=240\text{MHz}$
 $f_{RF}=1880\sim 1920\text{MHz}, P_{RF}=-40\text{dBm}$
 $f_{RF\ OFFSET}=600\text{kHz}$
 Lower LOCAL, $P_{LO}=-15\text{dBm}$
 $V_{CTL1}=0\text{V}, V_{CTL2}=2.7\text{V}$
 $V_{LNA}=V_{MIX}=V_{LO}=2.7\text{V}$

$$\text{OIP3}=(3\times\text{IF}-\text{IM3})/2$$

$$\text{IIP3}=\text{OIP3}-G_c$$

NJG1723KT2

■特性例 (Rx 部 : ANT SW+LNA+MIXER 特性)

**Conversion Gain vs. LO Power
Temperature Response**

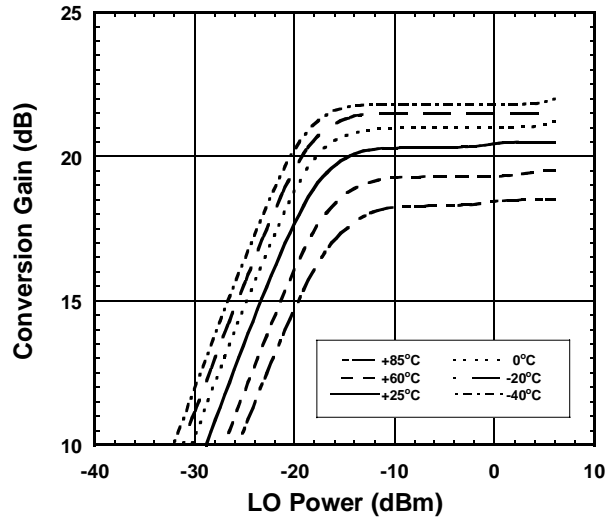

Condition
 $f_{IF}=240\text{MHz}$
 $f_{RF}=1900\text{MHz}, P_{RF}=-45\text{dBm}$
 $f_{LO}=1660\text{MHz}$
 $V_{CTL1}=0\text{V}, V_{CTL2}=2.7\text{V}$
 $V_{LNA}=V_{MIX}=V_{LO}=2.7\text{V}$

**Noise Figure vs. LO Power
Temperature Response**

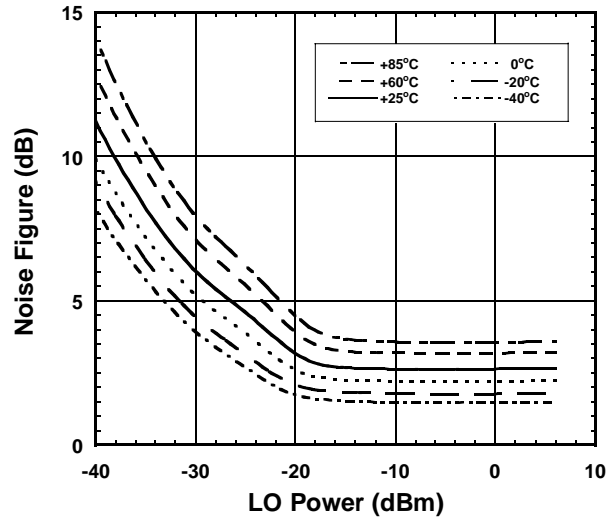

Condition
 $f_{IF}=240\text{MHz}$
 $f_{RF}=1900\text{MHz}$
 $f_{LO}=1660\text{MHz}$
 $V_{CTL1}=0\text{V}, V_{CTL2}=2.7\text{V}$
 $V_{LNA}=V_{MIX}=V_{LO}=2.7\text{V}$

**IIP3 vs. LO Power
Temperature Response**

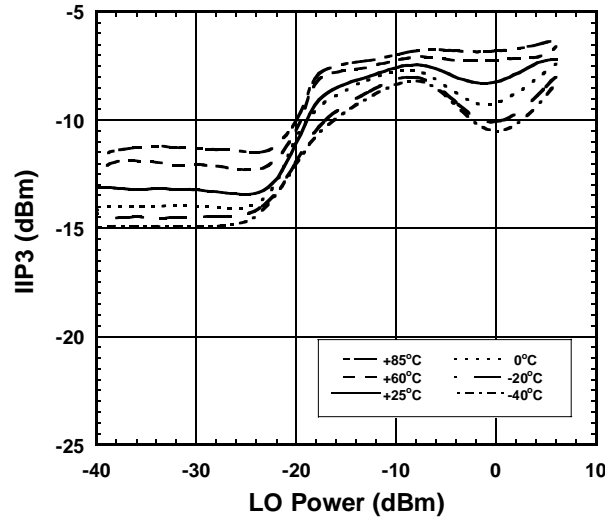

Condition
 $f_{IF}=240\text{MHz}$
 $f_{RF}=1900\text{MHz}, P_{RF}=-40\text{dBm}$
 $f_{RF\ OFFSET}=600\text{kHz}$
 $f_{LO}=1660\text{MHz}$
 $V_{CTL1}=0\text{V}, V_{CTL2}=2.7\text{V}$
 $V_{LNA}=V_{MIX}=V_{LO}=2.7\text{V}$

$OIP3=(3 \times I_F - IM3)/2$
 $IIP3=OIP3 - G_c$

I_{LNA}, I_{MIX}, I_{LO} vs. Temperature

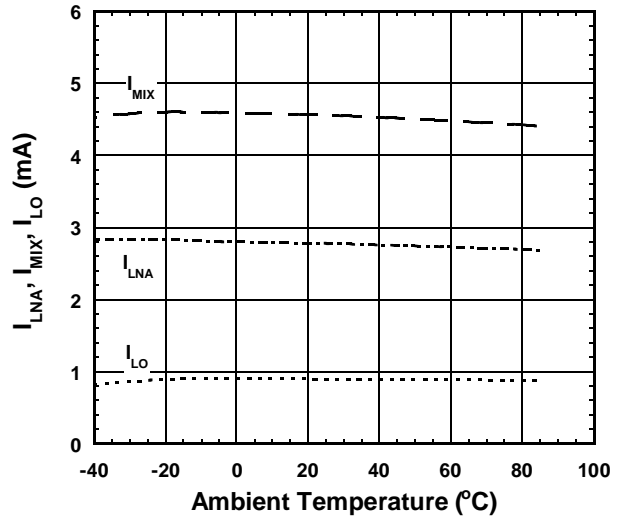

Condition
 $V_{LNA}=V_{MIX}=V_{LO}=2.7\text{V}$

■ TYPICAL CHARACTERISTICS (RX: ANT SW + LNA + MIXER SECTION)

ANT to LOCAL IN K factor vs. Frequency LOCAL IN to IF OUT K factor vs. Frequency Temperature Response Temperature Response

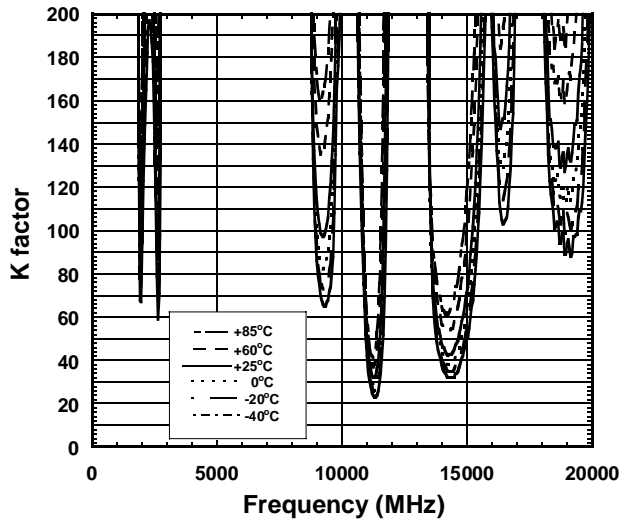

Condition
 IF OUT 50ohm term.
 $V_{CTL1}=0V, V_{CTL2}=2.7V$
 $V_{LNA}=V_{MIX}=V_{LO}=2.7V$

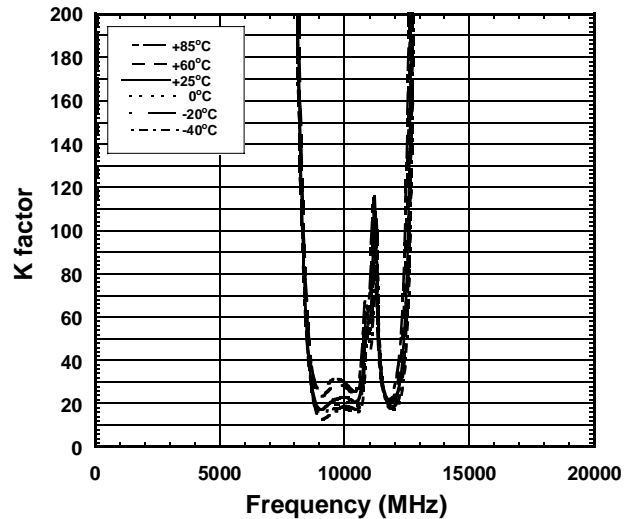

Condition
 ANT 50ohm term.
 $V_{CTL1}=0V, V_{CTL2}=2.7V$
 $V_{LNA}=V_{MIX}=V_{LO}=2.7V$

ANT to IF OUT IN K factor vs. Frequency Temperature Response

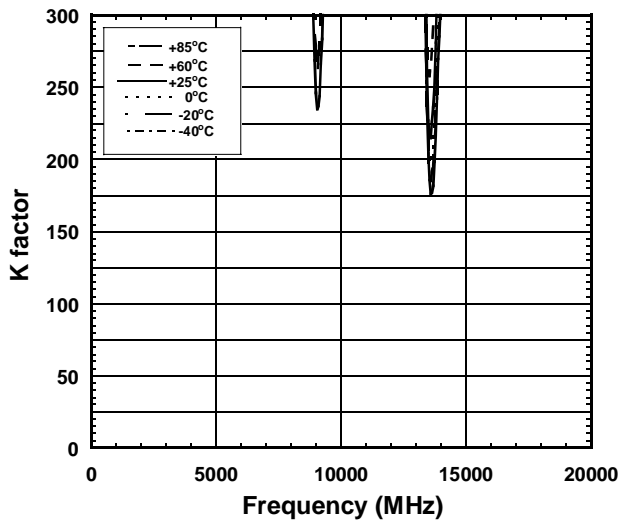

Condition
 LOCAL IN 50ohm term.
 $V_{CTL1}=0V, V_{CTL2}=2.7V$
 $V_{LNA}=V_{MIX}=V_{LO}=2.7V$

NJG1723KT2

TEST CIRCUIT

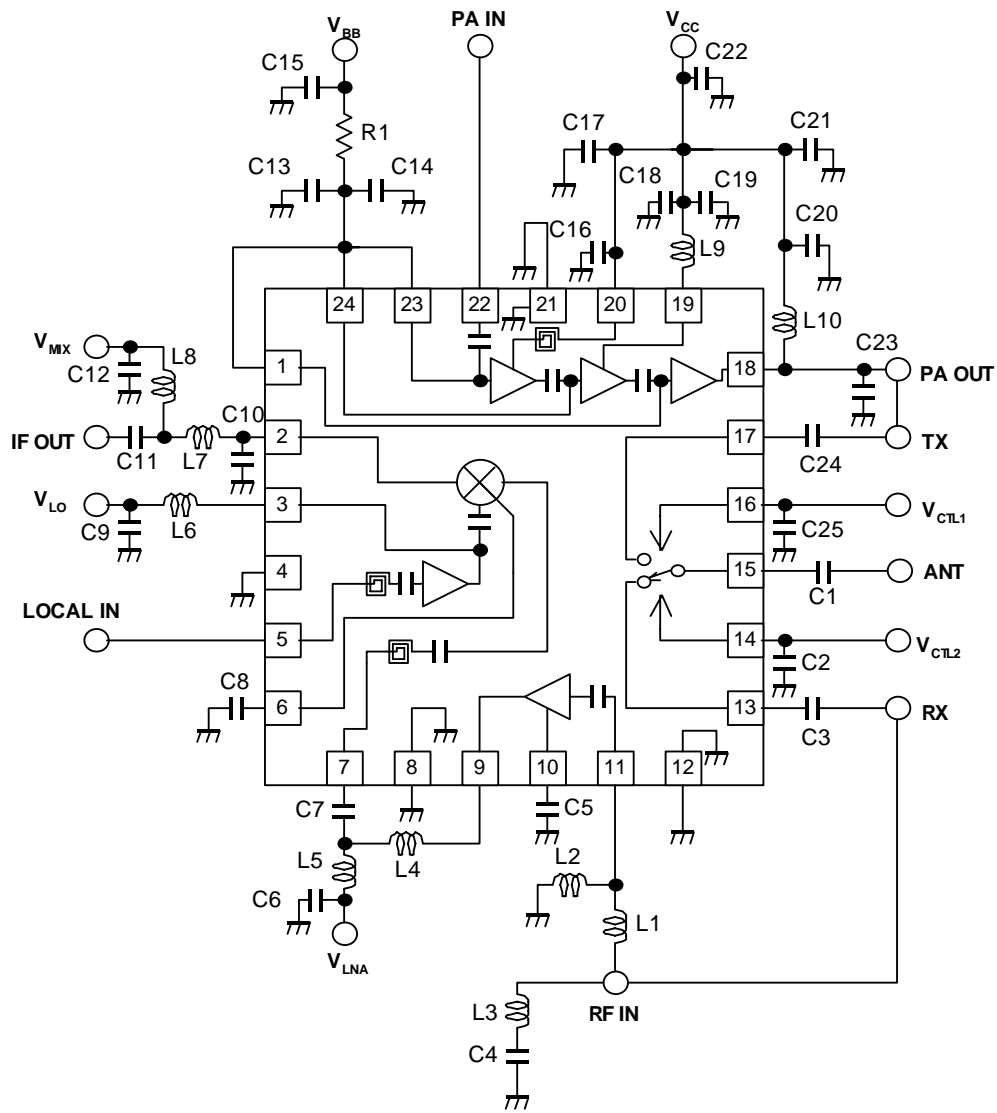

■ PARTS LIST

Parts ID	Constant	Comment
L1	6.8nH	TAIYO-YUDEN (HK1005)
L2	22nH	TAIYO-YUDEN (HK1005)
L3	6.8nH	TAIYO-YUDEN (HK1005)
L4	3.9nH	TAIYO-YUDEN (HK1005)
L5	1.5nH	TAIYO-YUDEN (HK1005)
L6	6.8nH	TAIYO-YUDEN (HK1005)
L7	39nH	TAIYO-YUDEN (HK1608)
L8	22nH	TAIYO-YUDEN (HK1005)
L9	1.0nH	TAIYO-YUDEN (HK1005)
L10	12nH	TAIYO-YUDEN (HK1608)
C1	56pF	MURATA (GRP15)
C2	10pF	MURATA (GRP15)
C3	56pF	MURATA (GRP15)
C4	2pF	MURATA (GRP15)
C5	1000pF	MURATA (GRP15)
C6	1000pF	MURATA (GRP15)
C7	4pF	MURATA (GRP15)
C8	1000pF	MURATA (GRP15)
C9	0.01μF	MURATA (GRP15)
C10	6pF	MURATA (GRP15)
C11	1000pF	MURATA (GRP15)
C12	0.01μF	MURATA (GRP15)
C13	33pF	MURATA (GRP15)
C14	0.1μF	MURATA (GRP15)
C15	1μF	MURATA (GRM18)
C16	33pF	MURATA (GRP15)
C17	0.01μF	MURATA (GRP15)
C18	33pF	MURATA (GRP15)
C19	0.01μF	MURATA (GRP15)
C20	33pF	MURATA (GRP15)
C21	0.01μF	MURATA (GRP15)
C22	1μF	MURATA (GRM18)
C23	2pF	MURATA (GRP15)
C24	56pF	MURATA (GRP15)
C25	10pF	MURATA (GRP15)
R1	47Ω	KOA (1005size)

NJG1723KT2

■ APPLIED CIRCUIT BOARD EXAMPLES

(Top View)

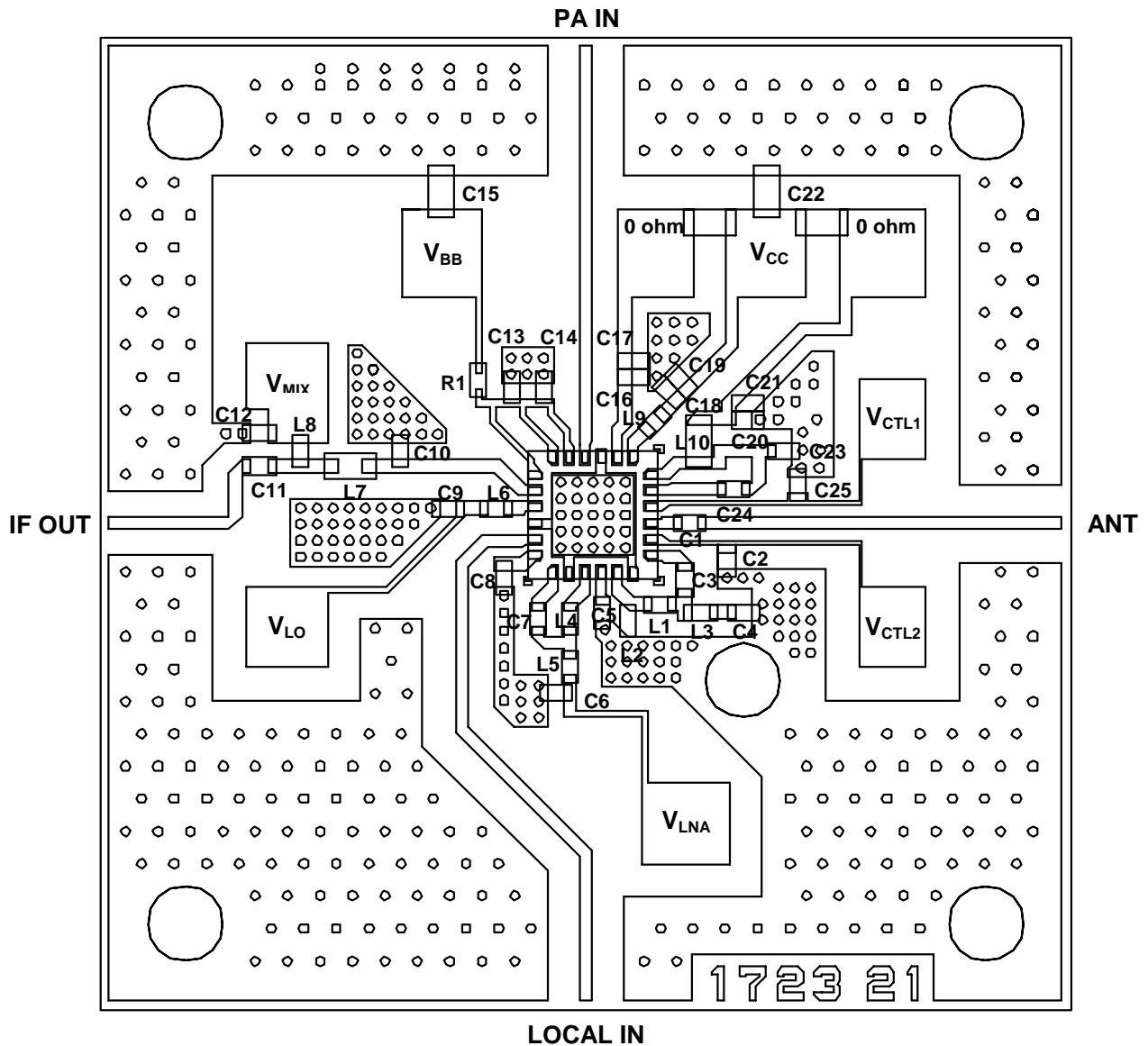

PCB (FR-4), t=0.2mm

MICROSTRIP LINE WIDTH=0.4mm($Z_0=50\Omega$)

PRECAUTIONS

1. Please locate C5 close to terminal No.10.
2. Please locate L6 close to terminal No.3.
3. Please locate C9 close to L6.
4. Please connect exposed GND PAD (bottom side of IC) to PCB GND using through holes as many as possible.
5. Please design the PCB structure that the dielectric thickness between the surface layer and the GND layer (directly under) is set to 0.2mm or more, about PCB of this device and external parts. However, the terminal of TAB GND of this device and the GND of external parts does not have these restrictions. Please design the GND layer pattern that can reduce a parasitism GND inductance as much as possible.

MEASUREMENT BLOCK DIAGRAM (TX: PA + ANT SW SECTION)

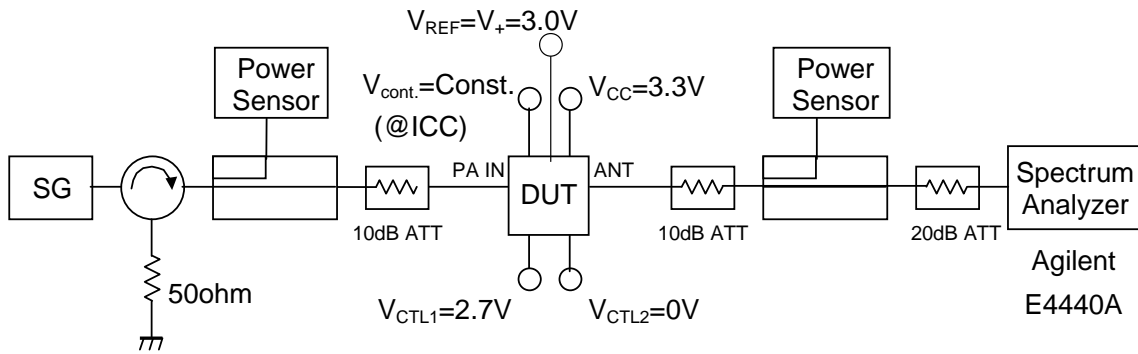

Tx mode (PA+ANT SW) Measurement Block Diagram

MEASUREMENT BLOCK DIAGRAM (RX: ANT SW + LNA + MIXER SECTION)

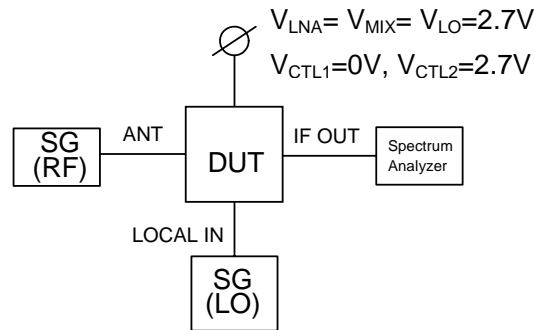

Conversion Gain Measurement Block Diagram

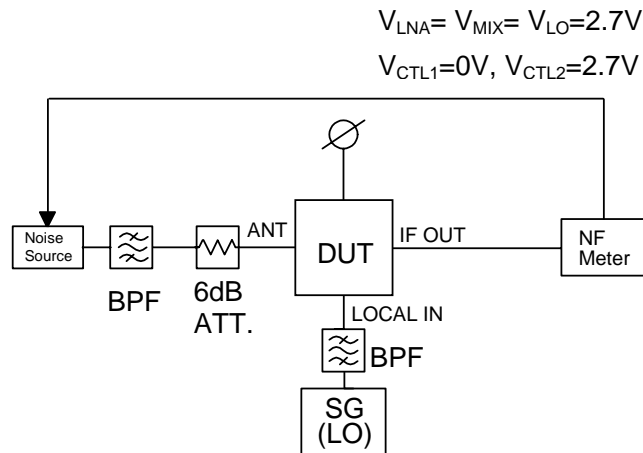

Noise Figure Measurement Block Diagram

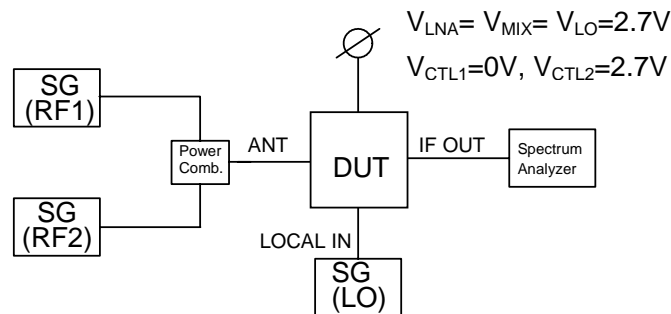

IF and IM3 measurement for IIP3

■ PACKAGE OUTLINE (QFN24-T2: 0.5pitch)

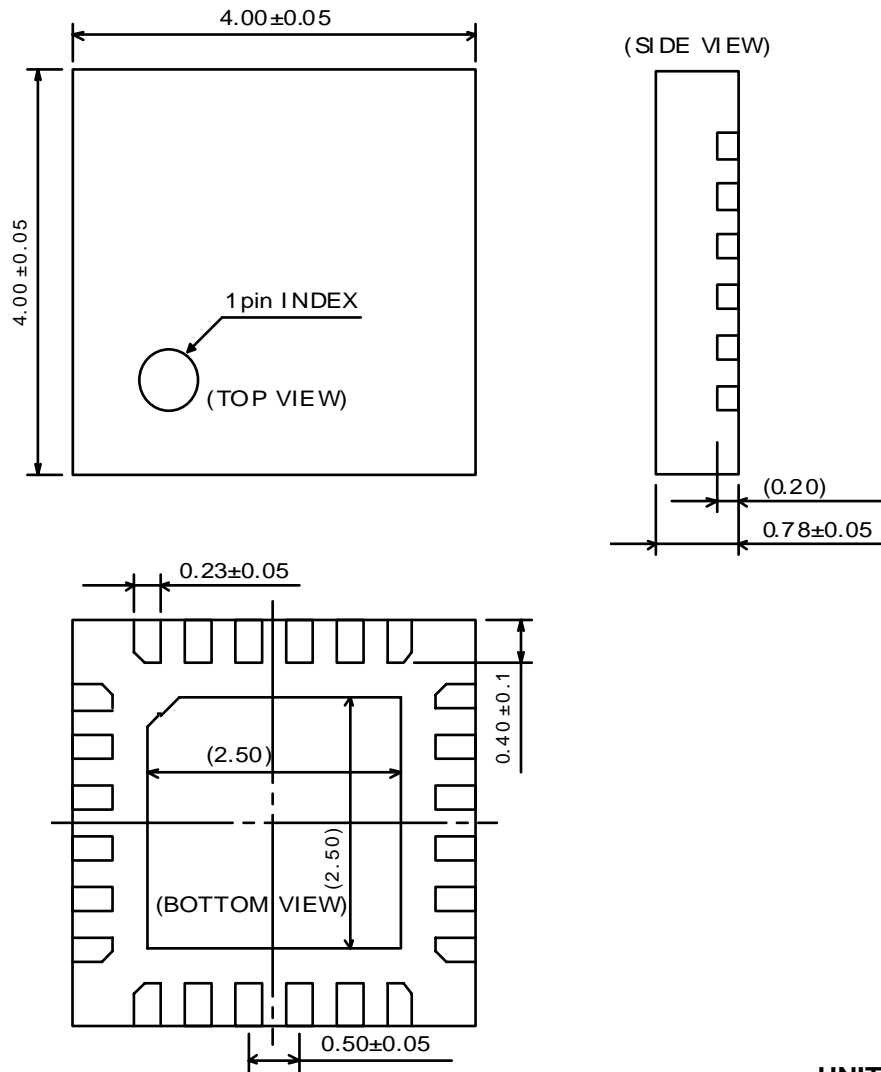

UNIT: mm

Cautions on using this product

- This product contains Gallium-Arsenide (GaAs) which is a harmful material.
- Do NOT eat or put into mouth.
 - Do NOT dispose in fire or break up this product.
 - Do NOT chemically make gas or powder with this product.
 - To waste this product, please obey the relating law of your country.

[CAUTION]

The specifications on this databook are only given for information, without any guarantee as regards either mistakes or omissions. The application circuits in this databook are described only to show representative usages of the product and not intended for the guarantee or permission of any right including the industrial rights.

This product may be damaged with electric static discharge (ESD) or spike voltage. Please handle with care to avoid these damages.