

Features

- Low Noise Figure
- Low Distortion
- Surface Mount Package
- Push-Pull Design Application
- Single Positive Supply

Description

M/A-COM's MAAMSS0001 is a GaAs PHEMT MMIC amplifier in a surface mount SOICN – 16 package. The MMIC design is configured as a pair of cascode PHEMT amplifiers for broadband performance. It is designed for integration in a 75-ohm push-pull low distortion amplifier circuit. The device is ideally suited for use in CATV, DBS, and DTV applications where low noise figure, low distortion and high linearity are required.

Functional Schematic

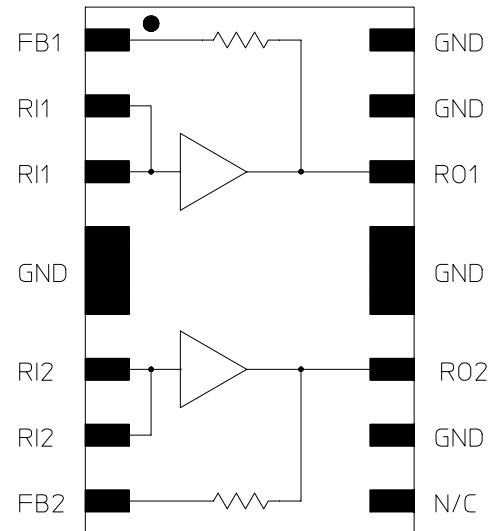

Ordering Information

Part Number	Package
MAAMSS0001	SOICN-16 Plastic Package
MAAMSS0001TR	7 inch, 1000 Piece Reel
MAAMSS0001SMB	Sample Test Board (Includes 5 Samples)

Absolute Maximum Ratings ¹

Parameter	Absolute Maximum
Input Power	+20 dBm
Operating Voltage	+10 volts
Operating Temperature	-40°C to +85°C
Storage Temperature	-65°C to +150°C

1. Exceeding any one or combination of these limits may cause permanent damage to this device.

Pin Configuration

PIN No.	PIN Name	Description
1	FB1	Feedback 1
2	RI1	RF Input 1
3	RI1	RF Input 1
4	GND	Ground
5	GND	Ground
6	RI2	RF Input 2
7	RI2	RF Input 2
8	FB2	Feedback 2
9	N/C	No Connection
10	GND	Ground
11	RO2	RF Output 2
12	GND	Ground
13	GND	Ground
14	RO1	RF Output 1
15	GND	Ground
16	GND	Ground

M/A-COM Inc. and its affiliates reserve the right to make changes to the product(s) or information contained herein without notice.

Visit www.macom.com for additional data sheets and product information.

- **North America:** Tel. (800) 366-2266
- **Asia/Pacific:** Tel. +81-44-844-8296, Fax +81-44-844-8298
- **Europe:** Tel. +44 (1908) 574 200, Fax +44 (1908) 574 300

Electrical Specifications: $T_A = 25^\circ\text{C}$, Freq: 50 - 870 MHz, $V_{DD} = +5$ Volts,
 $Z_0 = 75$ ohms, Test Circuit with M/A-COM Balun ETN1-1-13TR

Parameter	Test Conditions	Units	Min.	Typ.	Max.
Gain		dB	11.5	12.0	13.0
Gain Flatness		dB		0.35	
Noise Figure	50-150 MHz	dB		3.8	4.0
	150-870 MHz	dB		2.8	
Input Return Loss		dB	10	15	
Output Return Loss		dB		11	
IP3	Two tones at 397 & 403 MHz, +4 dBm output per tone	dBm		33	
Composite Triple Beat, CTB	135 Channels, +25 dBmV/ Channel at the output	dBc		-72.5	-70
Composite Second Order, CSO	135 Channels, +25 dBmV/ Channel at the output	dBc		-75	-70
Cross modulation	135 Channels, +25 dBmV/ Channel at the output	dBc		-64	
P1dB	400 MHz	dBm		23	
I_{DD}	+ 5 Volts	mA		190	225

Handling Procedures

The following precautions should be observed to avoid damage:

Static Sensitivity

Gallium Arsenide Integrated Circuits are sensitive to electrostatic discharge (ESD) and can be damaged by static electricity. Proper ESD control techniques should be used when handling these devices.

M/A-COM Inc. and its affiliates reserve the right to make changes to the product(s) or information contained herein without notice.

Visit www.macom.com for additional data sheets and product information.

2

- North America: Tel. (800) 366-2266
- Asia/Pacific: Tel. +81-44-844-8296, Fax +81-44-844-8298
- Europe: Tel. +44 (1908) 574 200, Fax +44 (1908) 574 300

tyco / Electronics

M/A-COM

Typical Performance Curves

Gain vs. Frequency over Temperature

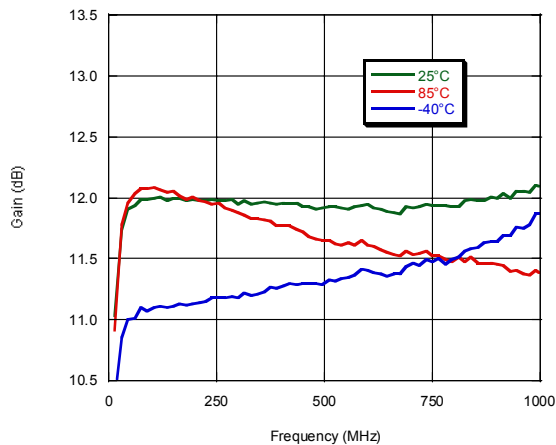

Gain vs. Frequency to 3 GHz over Temperature

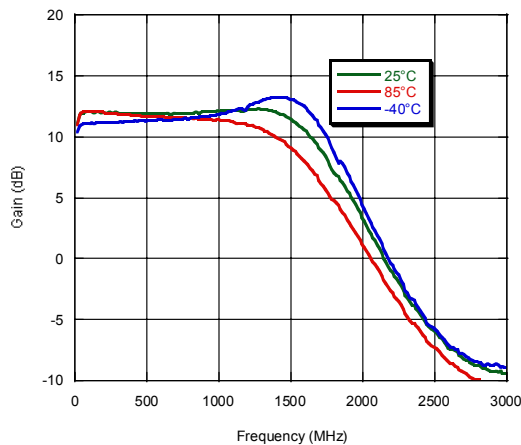

Input Return Loss vs. Frequency over Temperature

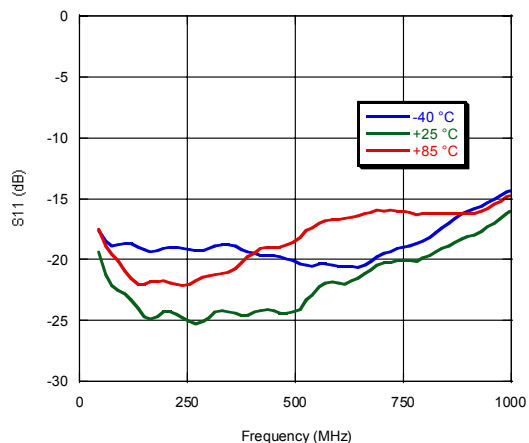

Output Return Loss vs. Frequency over Temperature

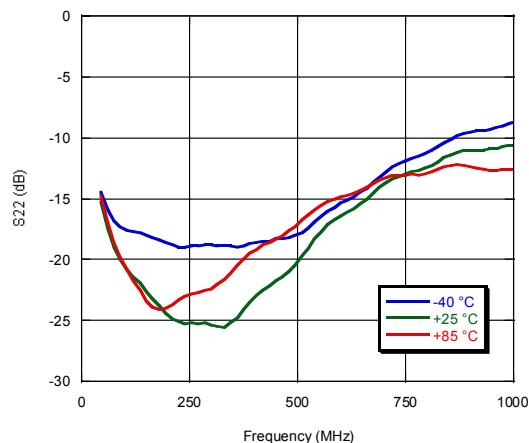

OIP3 vs. P_{IN} at 400 MHz, 25°C

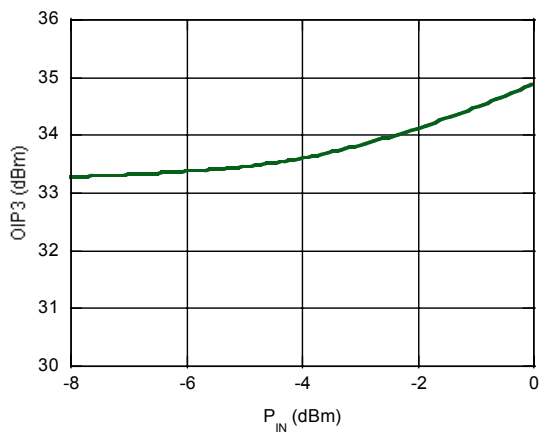

Noise Figure vs. Frequency, 25°C

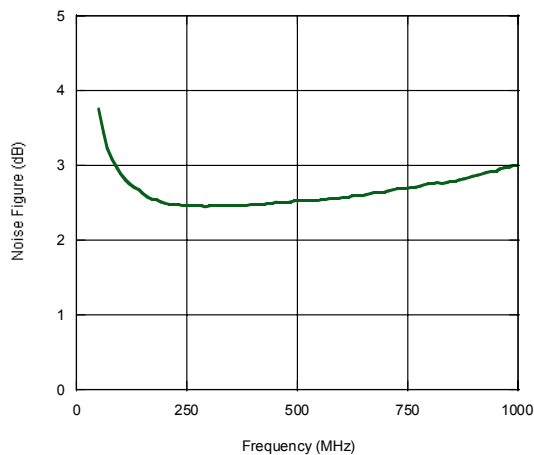

M/A-COM Inc. and its affiliates reserve the right to make changes to the product(s) or information contained herein without notice.

Visit www.macom.com for additional data sheets and product information.

- North America: Tel. (800) 366-2266
- Asia/Pacific: Tel. +81-44-844-8296, Fax +81-44-844-8298
- Europe: Tel. +44 (1908) 574 200, Fax +44 (1908) 574 300

Typical Performance Curves (continued)

Gain vs P_{OUT} at 400 MHz vs. Temperature

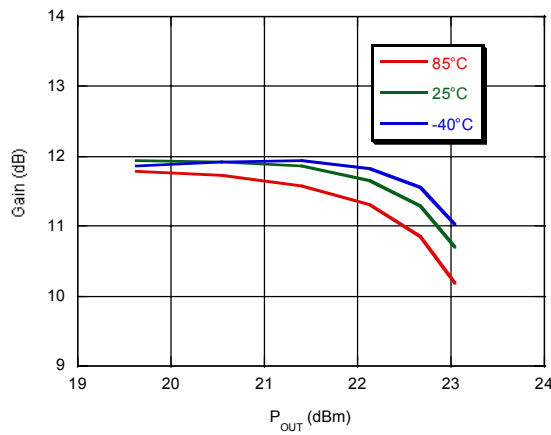

SOICN-16²

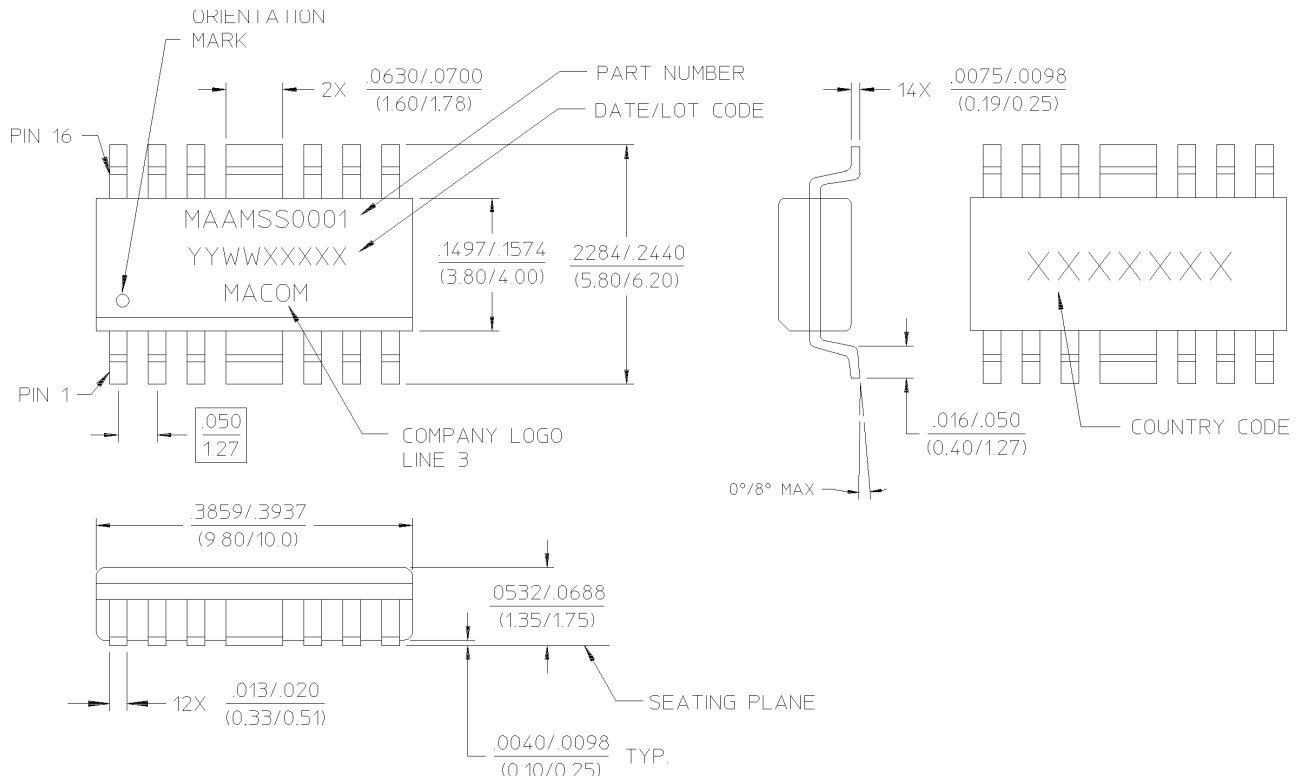

2. All dimensions shown as inches/mm.

M/A-COM Inc. and its affiliates reserve the right to make changes to the product(s) or information contained herein without notice.

Visit www.macom.com for additional data sheets and product information.

- North America: Tel. (800) 366-2266
- Asia/Pacific: Tel. +81-44-844-8296, Fax +81-44-844-8298
- Europe: Tel. +44 (1908) 574 200, Fax +44 (1908) 574 300

Test Circuit Schematic

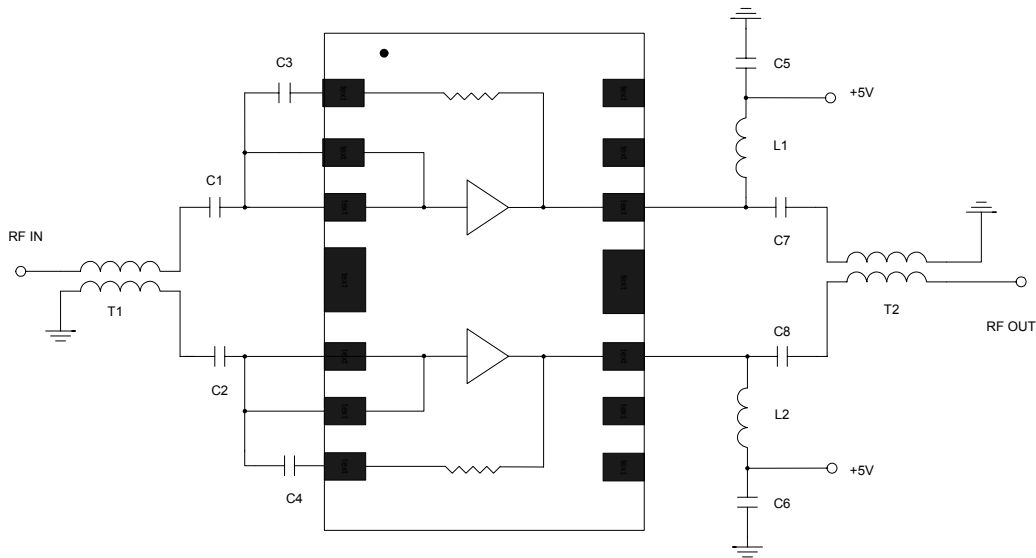

The 1:1 baluns, T1 & T2, are M/A-COM part number ETN1-1-13TR.

Recommended PCB Configuration with 0.031" thick FR4

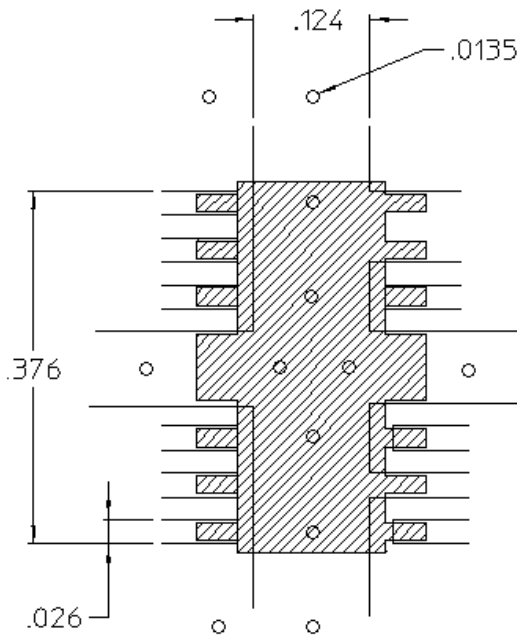

Recommended Test Circuit Layout

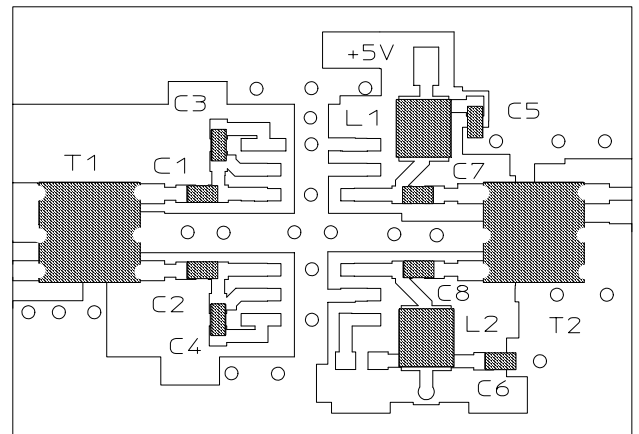

External Circuitry Parts List

Qty	Description	
8	Capacitor, 0.01uF, 0603, SMT, 10%	(C1-C8)
2	Inductor, 390 nH, 1008, SMT, 10%	(L1, L2)
2	Balun, 1:1, M/A-COM, ETN1-1-13TR, SMT	(T1, T2)

M/A-COM Inc. and its affiliates reserve the right to make changes to the product(s) or information contained herein without notice.

Visit www.macom.com for additional data sheets and product information.

- North America: Tel. (800) 366-2266
- Asia/Pacific: Tel. +81-44-844-8296, Fax +81-44-844-8298
- Europe: Tel. +44 (1908) 574 200, Fax +44 (1908) 574 300

