

Features

- Low Distortion
- Low Noise Figure
- Push Pull Design
- Single Positive Supply
- Lead-Free 4 mm 20-Lead PQFN Package
- 100% Matte Tin Plating over Copper
- Halogen-Free "Green" Mold Compound
- RoHS* Compliant and 260°C Reflow Compatible

Description

M/A-COM's MAAM-007724 is a GaAs PHEMT MMIC amplifier in a lead-free 4 mm 20-lead PQFN package. The MMIC design is configured as a pair of cascode PHEMT amplifiers for broadband performance. It is designed for integration in a 75-ohm push-pull, low distortion, amplifier circuit. The device is ideally suited for use in CATV, DBS, and HDTV applications where low noise figure and low distortion are required.

Ordering Information ¹

Part Number	Package
MAAM-007724-TR1000	1000 piece reel
MAAM-007724-TR3000	3000 piece reel
MAAM-007724-000SMB	Sample Test Board (Includes 5 Samples)

1. Reference Application Note M513 for reel size information.

Absolute Maximum Ratings ^{2,3}

Parameter	Absolute Maximum
Input Power	+20 dBm
Operating Voltage	+10 volts
Operating Temperature	-40°C to +85°C
Storage Temperature	-65°C to +150°C

- Exceeding any one or combination of these limits may cause permanent damage to this device.
- M/A-COM does not recommend sustained operation near these survivability limits.

Functional Schematic

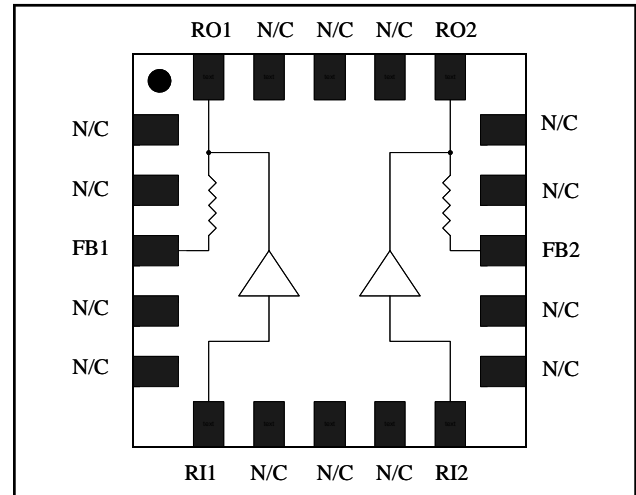

Pin Configuration ⁴

Pin No.	Pin Name	Description
1	N/C	No Connection
2	N/C	No Connection
3	FB1	Feedback 1
4	N/C	No Connection
5	N/C	No Connection
6	RI1	RF Input 1
7	N/C	No Connection
8	N/C	No Connection
9	N/C	No Connection
10	RI2	RF Input 2
11	N/C	No Connection
12	N/C	No Connection
13	FB2	Feedback 2
14	N/C	No Connection
15	N/C	No Connection
16	RO2	RF Output 2
17	N/C	No Connection
18	N/C	No Connection
19	N/C	No Connection
20	RO1	RF Output 1

4. The exposed pad centered on the package bottom must be connected to RF and DC ground.

* Restrictions on Hazardous Substances, European Union Directive 2002/95/EC.

ADVANCED: Data Sheets contain information regarding a product M/A-COM Technology Solutions is considering for development. Performance is based on target specifications, simulated results, and/or prototype measurements. Commitment to develop is not guaranteed.
PRELIMINARY: Data Sheets contain information regarding a product M/A-COM Technology Solutions has under development. Performance is based on engineering tests. Specifications are typical. Mechanical outline has been fixed. Engineering samples and/or test data may be available. Commitment to produce in volume is not guaranteed.

• **North America** Tel: 800.366.2266 / Fax: 978.366.2266
 • **Europe** Tel: 44.1908.574.200 / Fax: 44.1908.574.300
 • **Asia/Pacific** Tel: 81.44.844.8296 / Fax: 81.44.844.8298
 Visit www.macomtech.com for additional data sheets and product information.

M/A-COM Technology Solutions Inc. and its affiliates reserve the right to make changes to the product(s) or information contained herein without notice.

Low Noise CATV Amplifier 50 - 1005 MHz

Rev. V1

Electrical Specifications: $T_A = 25^\circ\text{C}$, Freq: 50 - 1005 MHz, $V_{DD} = +5$ Volts, $Z_0 = 75$ ohms
Test Circuit with M/A-COM Balun ETN1-1-13

Parameter	Test Conditions	Units	Min.	Typ.	Max.
Gain	—	dB	11.5	12.2	13.0
Gain Flatness	—	dB	—	0.4	1.0
Noise Figure	—	dB	—	3.3	4.0
Input VSWR	—	Ratio	—	1.3:1	—
Output VSWR	—	Ratio	—	1.5:1	—
Output IP3	Two tones at 397 & 403 MHz, +4 dBm output per tone	dBm	—	32	—
Composite Triple Beat, CTB	135 Channels, +13 dBmV/Channel at the input	dBc	—	-78	-70
Composite Second Order, CSO	135 Channels, +13 dBmV/Channel at the input	dBc	—	-78	-70
Cross modulation	135 Channels, +13 dBmV/Channel at the input	dBc	—	-73	-64
P1dB	400 MHz	dBm	—	24	—
I_{DD}	+5 Volts	mA	—	190	225

Test Circuit Schematic⁵

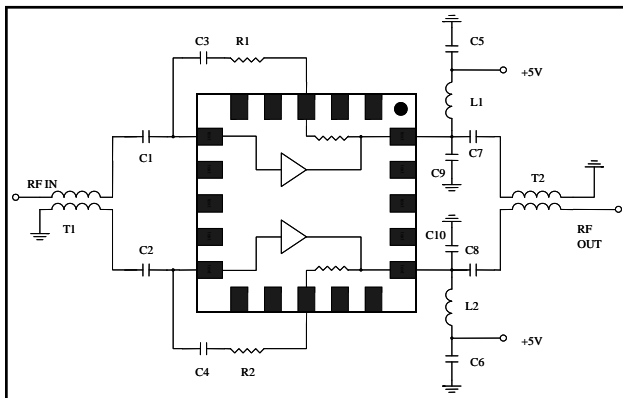

5. The 1:1 baluns, T1 & T2, are M/A-COM part number ETN1-1-13.

Recommended Test Circuit Layout⁶

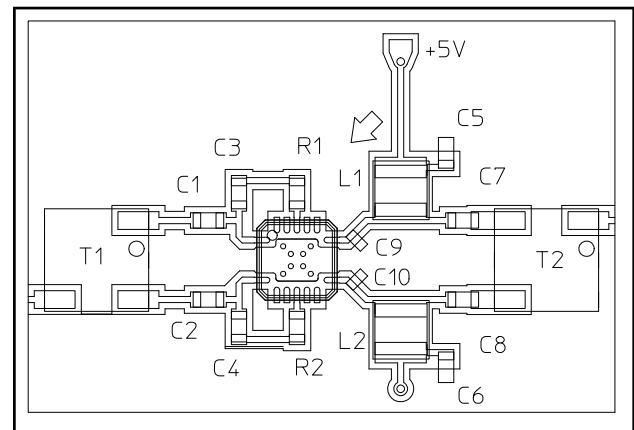

6. Reference M/A-COM Application Note S2083 for recommended PCB configuration. R1 and R2 are 0 ohms.

External Circuitry Parts List

Qty	Description
8	Capacitor, 0.01 μF , 0603, SMT, 10% (C1-C8)
2	Capacitor, 2 pF, 0402, SMT, $\pm 0.25\text{pF}$ (C9-C10)
2	Inductor, 390 nH, 1008, SMT, 10% (L1, L2)
2	Balun, 1:1, M/A-COM, ETN1-1-13, SMT (T1,T2)
2	Resistor, 0 ohms, 0603, SMT (R1, R2)

Handling Procedures

Please observe the following precautions to avoid damage:

Static Sensitivity

Gallium Arsenide Integrated Circuits are sensitive to electrostatic discharge (ESD) and can be damaged by static electricity. Proper ESD control techniques should be used when handling these devices.

2

ADVANCED: Data Sheets contain information regarding a product M/A-COM Technology Solutions is considering for development. Performance is based on target specifications, simulated results, and/or prototype measurements. Commitment to develop is not guaranteed.
PRELIMINARY: Data Sheets contain information regarding a product M/A-COM Technology Solutions has under development. Performance is based on engineering tests. Specifications are typical. Mechanical outline has been fixed. Engineering samples and/or test data may be available. Commitment to produce in volume is not guaranteed.

- **North America** Tel: 800.366.2266 / Fax: 978.366.2266
- **Europe** Tel: 44.1908.574.200 / Fax: 44.1908.574.300
- **Asia/Pacific** Tel: 81.44.844.8296 / Fax: 81.44.844.8298

Visit www.macomtech.com for additional data sheets and product information.

M/A-COM Technology Solutions Inc. and its affiliates reserve the right to make changes to the product(s) or information contained herein without notice.

Typical Performance Curves

Gain

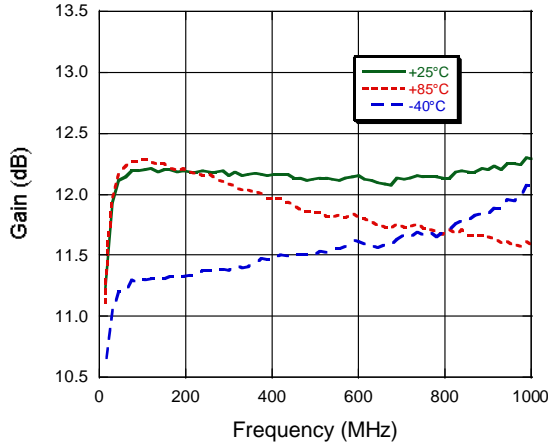

Gain vs. Frequency to 3 GHz

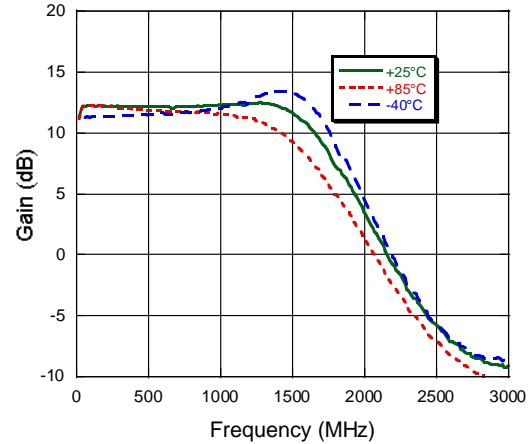

Input Return Loss

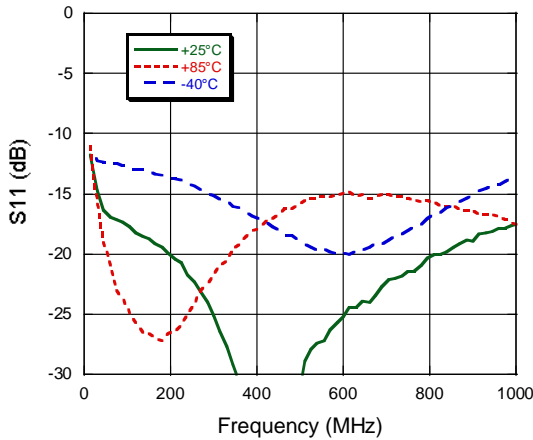

Output Return Loss

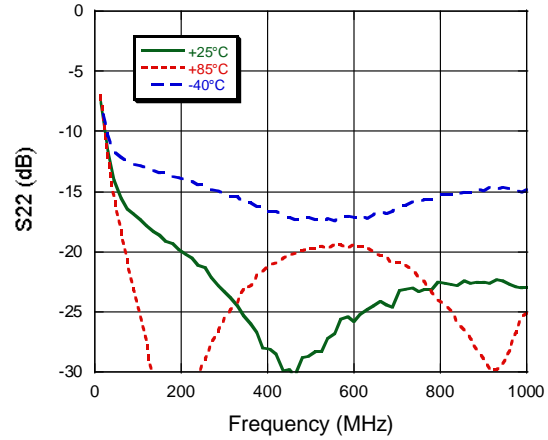

OIP

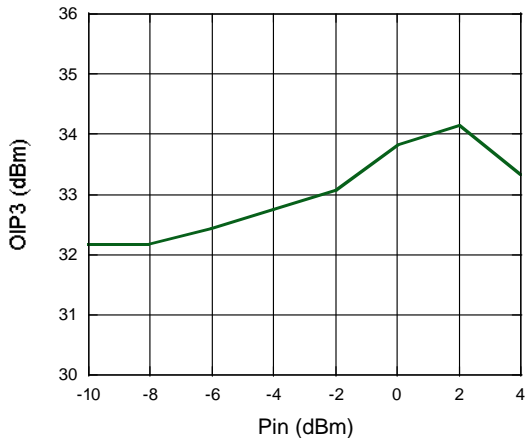

Noise Figure vs. Frequency, 25°C

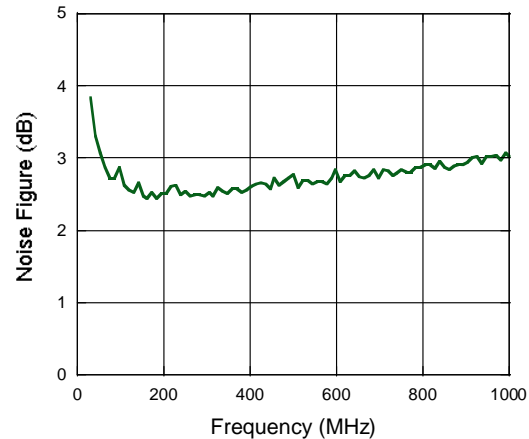

ADVANCED: Data Sheets contain information regarding a product M/A-COM Technology Solutions is considering for development. Performance is based on target specifications, simulated results, and/or prototype measurements. Commitment to develop is not guaranteed.
PRELIMINARY: Data Sheets contain information regarding a product M/A-COM Technology Solutions has under development. Performance is based on engineering tests. Specifications are typical. Mechanical outline has been fixed. Engineering samples and/or test data may be available. Commitment to produce in volume is not guaranteed.

- **North America** Tel: 800.366.2266 / Fax: 978.366.2266
- **Europe** Tel: 44.1908.574.200 / Fax: 44.1908.574.300
- **Asia/Pacific** Tel: 81.44.844.8296 / Fax: 81.44.844.8298

Visit www.macomtech.com for additional data sheets and product information.

M/A-COM Technology Solutions Inc. and its affiliates reserve the right to make changes to the product(s) or information contained herein without notice.

Typical Performance Curves (continued)

Gain vs. P_{OUT} at 400 MHz

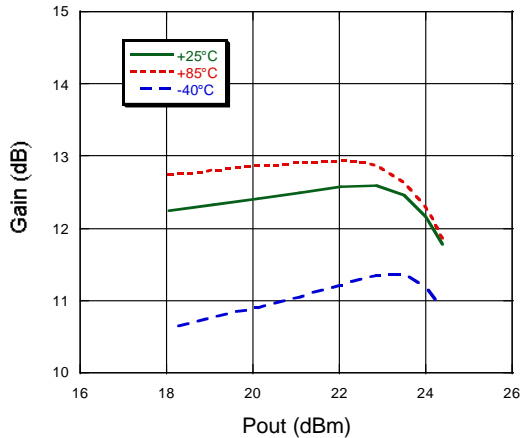

Lead-Free 4 mm 20-lead PQFN†

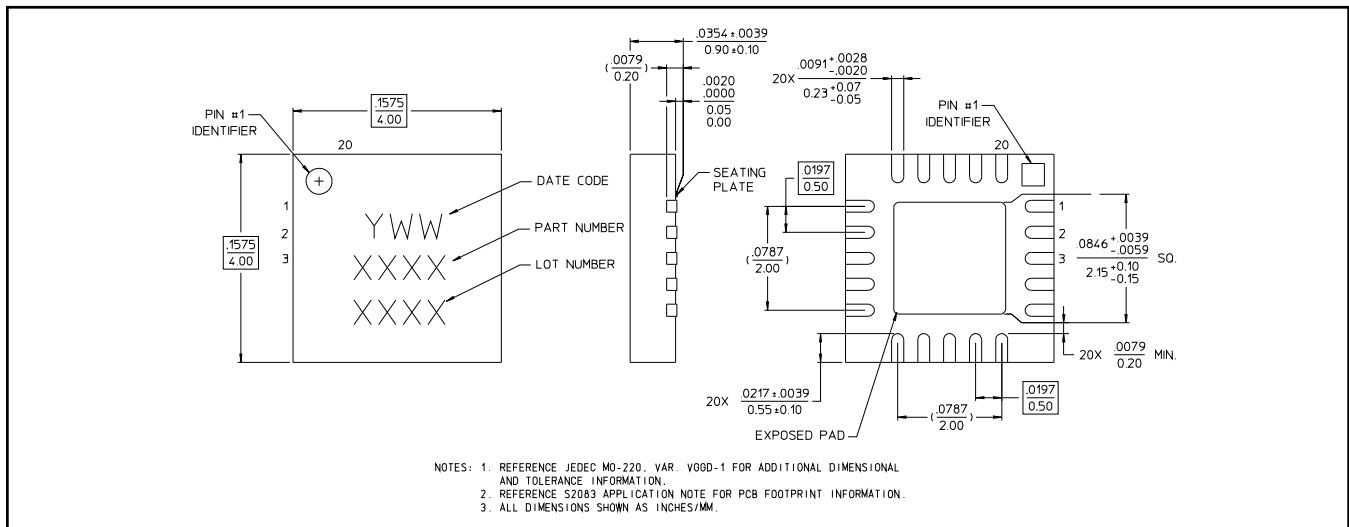

† Reference Application Note M538 for lead-free solder reflow recommendations.
Meets JEDEC moisture sensitivity level 1 requirements.