

Broadband Driver Amplifier 50 to 2000 MHz

Rev. V2

Features

- High Gain: 20 dB (TYP.)
- Flat Broadband Gain Response: +/- 1.3 dB (TYP)
- P1dB: +18.0 dBm (TYP.)
- Flexibility for Multi-Band Systems
- On-Chip Active Bias Network
- Lead Free 3 mm PQFN Surface Mount Package
- 260°C Reflow Capability

Applications

- LO Buffer Amplifier
- Driver Stage for Power Amplifiers
- Basestation / Repeater Applications
- Broadband RF Gain Block

Description

M/A-COM's MAAM-007865-0P1R00 amplifier utilizes GaAs HBT technology with an +18 Volt BV_{ceo} process for improved linearity performance, power efficiency, and high reliability, in a low cost 3 mm PQFN surface mount plastic package.

The MAAM-007865-0P1R00 incorporates an on-chip active bias network for ease of implementation, and maintains high linearity over temperature. The device operates from a single +5 volt supply and has a +5 volt reference pin for power down control capability. An external dropping resistor can be added to lower the P1dB level by 4 dB.

The MAAM-007865-0P1R00 requires a minimal number of external bias components to achieve a flat gain response across the entire 50 to 2000 MHz frequency band.

Ordering Information¹

Part Number	Package
MAAM-007865-0P1R00	3 mm 12 lead PQFN
MAAM-007865-0P1RA1	Sample Application Kit
MAAM-007865-0P1RTR	1000 Piece Tape & Reel

1. Reference Application Note M513 for reel size information.

Product Image

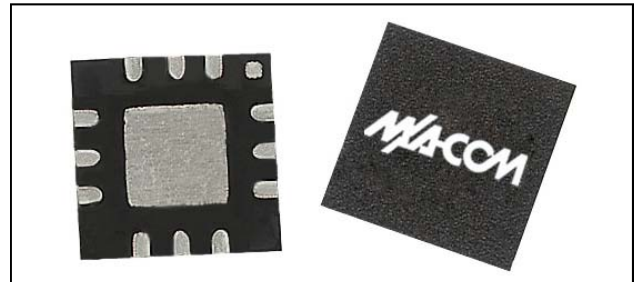

Functional Block Diagram

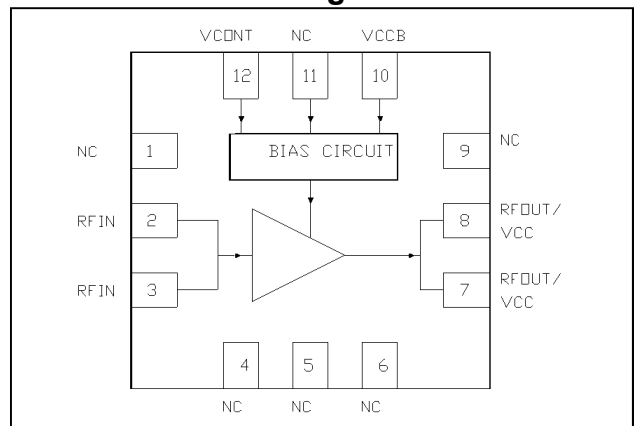

Pin Configuration

Pin No.	Function	Description
1	No Connection	No connection
2	RF Input	RF Input Signal
3	RF Input	RF Input Signal
4	No Connection or GND	No Connection. GND preferred
5	No Connection or GND	No Connection. GND preferred
6	No Connection or GND	No Connection. GND preferred
7	RF Output / VCC	RF Output & VCC Supply Input
8	RF Output / VCC	RF Output & VCC Supply Input
9	No Connection	No Connection
10	VCCB	VCC Supply to Bias Circuit. Connected to VCONT on PCB. Optionally could be connected to VCC instead of VCONT.
11	No Connection	Normally not connected or Open. Must not be connected to GND.
12	VCONT	DC Control Input to PA. External resistor required for normal operation @ +5 V. See Application Circuit.
Pkg Base	GND	RF/DC GND and thermal Path to PCB Vias. Sufficient Vias must be provided for thermal considerations. See PCB Layout

Electrical Specifications¹: T_c = +25°C, V_{CONT} = 5 V, V_{CC} = 5 V, Z₀ = 50 Ω, CW

Parameter	Test Conditions	Units	Min	Typ	Max
Frequency Range		MHz	50		2000
Gain		dB		20	
Gain Flatness		dB		+/-1.3	
Gain Variation	Over Temp = - 40°C to +85°C	dB		1.6	
Input Return Loss	Over Frequency	dB			-10
Output Return Loss	Over Frequency	dB			-10
Reverse Isolation		dB		-28	
Output P-1dB	50 to 1000 MHz	dBm		18.5	
	1000 to 2000 MHz	dBm		17	
Output IP3	P _{out} = - 1dBm / tone, Δf = 1MHz	dBm		29.5	
Noise Figure		dB		5	
Bias Supply	VCC	V		5	6
Control Voltage	VCONT Amp ON	V		5	
	VCONT Amp OFF	V			2
Bias Current	Quiescent Current I _{ccq}	mA		42	47
	Control current I _{cont}	mA		9	12
Thermal Resistance θ _{jc}		°C/W	TBD		
Junction Temperature Rise Above Case T _{jc}		°C	TBD		

1. All data is based on the Evaluation Circuit Board (page 5).
2. Caution: Operation beyond Absolute Maximum Ratings can degrade performance or cause permanent damage.

Operating the MAAM-007865-0P1R00

The MAAM-007865-0P1R00 can be damaged by electrostatic discharge (ESD). Use proper ESD control techniques when handling this device. To operate the MAAM-007865-0P1R00, follow these steps:

- 1.) Connect the 50 ohm load
- 2.) Apply VCC (+5.0 Vdc)
- 3.) Apply VCONT (+5.0 Vdc)
- 4.) Set the Input Power Level (P_{in})
- 5.) Turn off in reverse order

Absolute Maximum Ratings²

Parameter	Absolute Maximum
RF Input Power	+ 3 dBm
Supply Voltage VCC	+ 6 V
Control Voltage VCONT	+ 5.5 V
VCC Supply Current	55 mA
Operating Temperature	-40°C to + 85°C
Storage Temperature	-65°C to +150°C
Device Junction Temperature T _j , max	150°C

Typical Performance Curves at +25°C (VCONT = +5V, 12mA, VCC = +5 V, 41 mA)

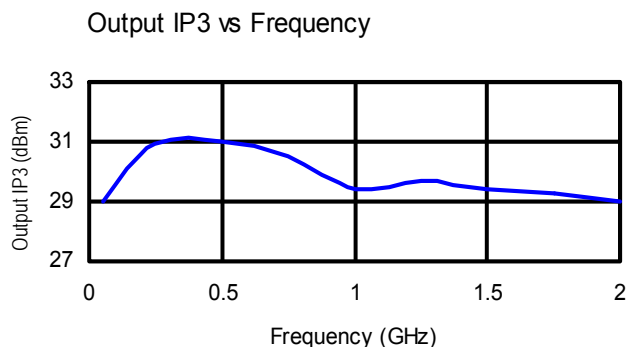
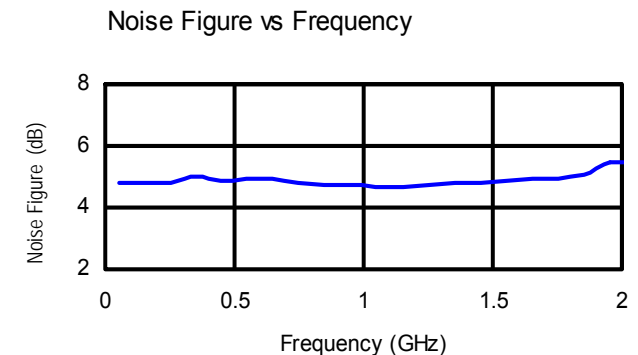
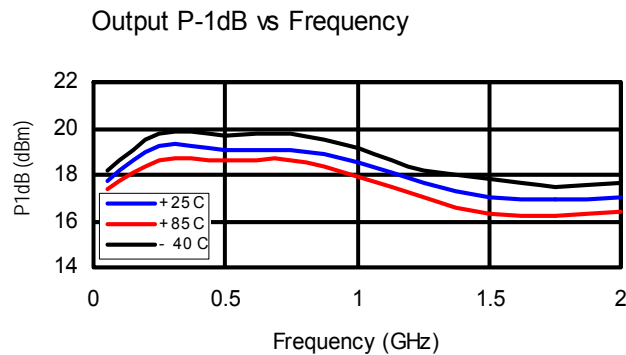
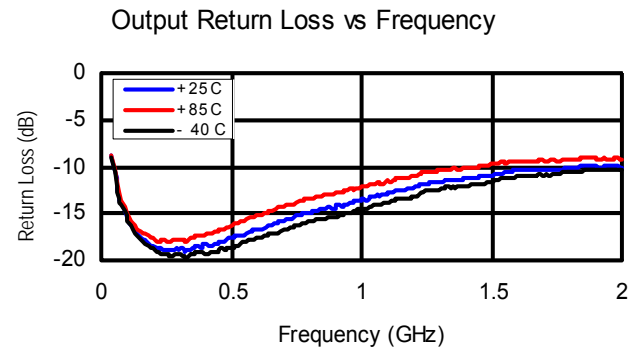
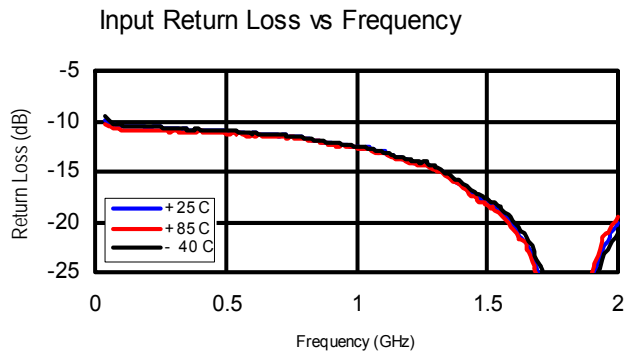
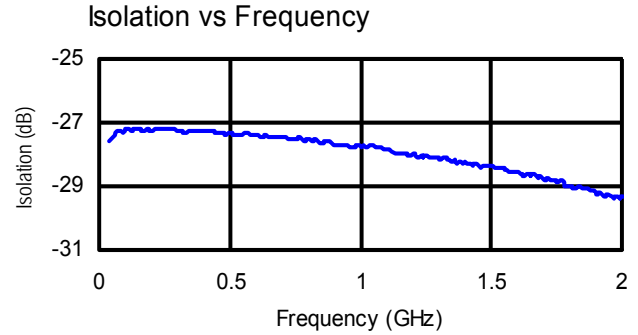
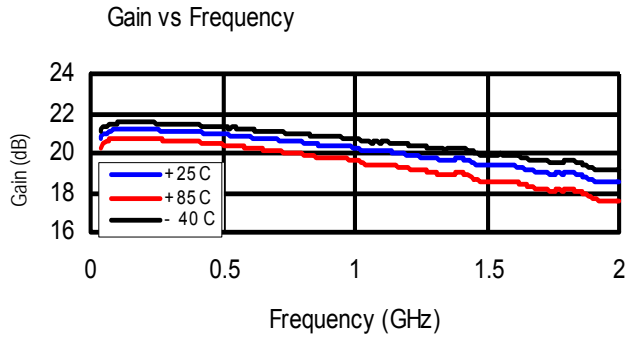

Application Circuit Schematic

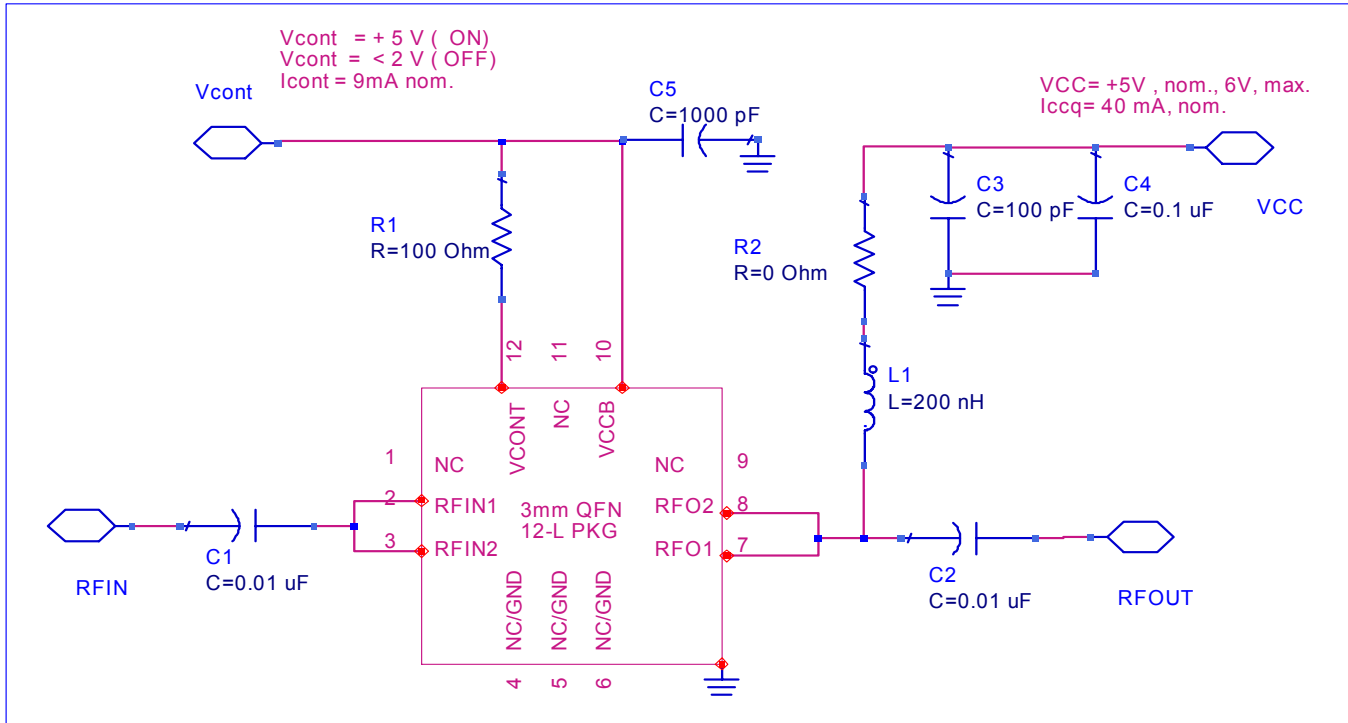

Evaluation Circuit Board Bill of Material

COMPONENT	PART NO	VALUE	SUGGESTED VENDOR
C1,C2	X7R0603HTTD103K	0.01uF	KOA
C3	NPO0402HHTTP101J	100pF	KOA
C4	X7R0603CTTD104K	0.1uF	KOA
C5	X7R0603HTTD102K	1000pF	KOA
L1	0603CS-R20XJBU	200nH	COILCRAFT
R1	RK73B1ETTP101J(0402)	100 OHM	KOA
R2	RK73Z1ELTP(0402)	000 OHM	KOA
J1, J2	142-0701-881	RF CONN	JOHNSON
J3	TSM-105-01-S-DV	DC CONN	
U1	MAAM-007865-0P1R00	3mm PQFN 12L	TYCO
PCB	1000028554-1	GETEK,28mil	TYCO

EVALUATION CIRCUIT BOARD LAYOUT^{1,2,3}

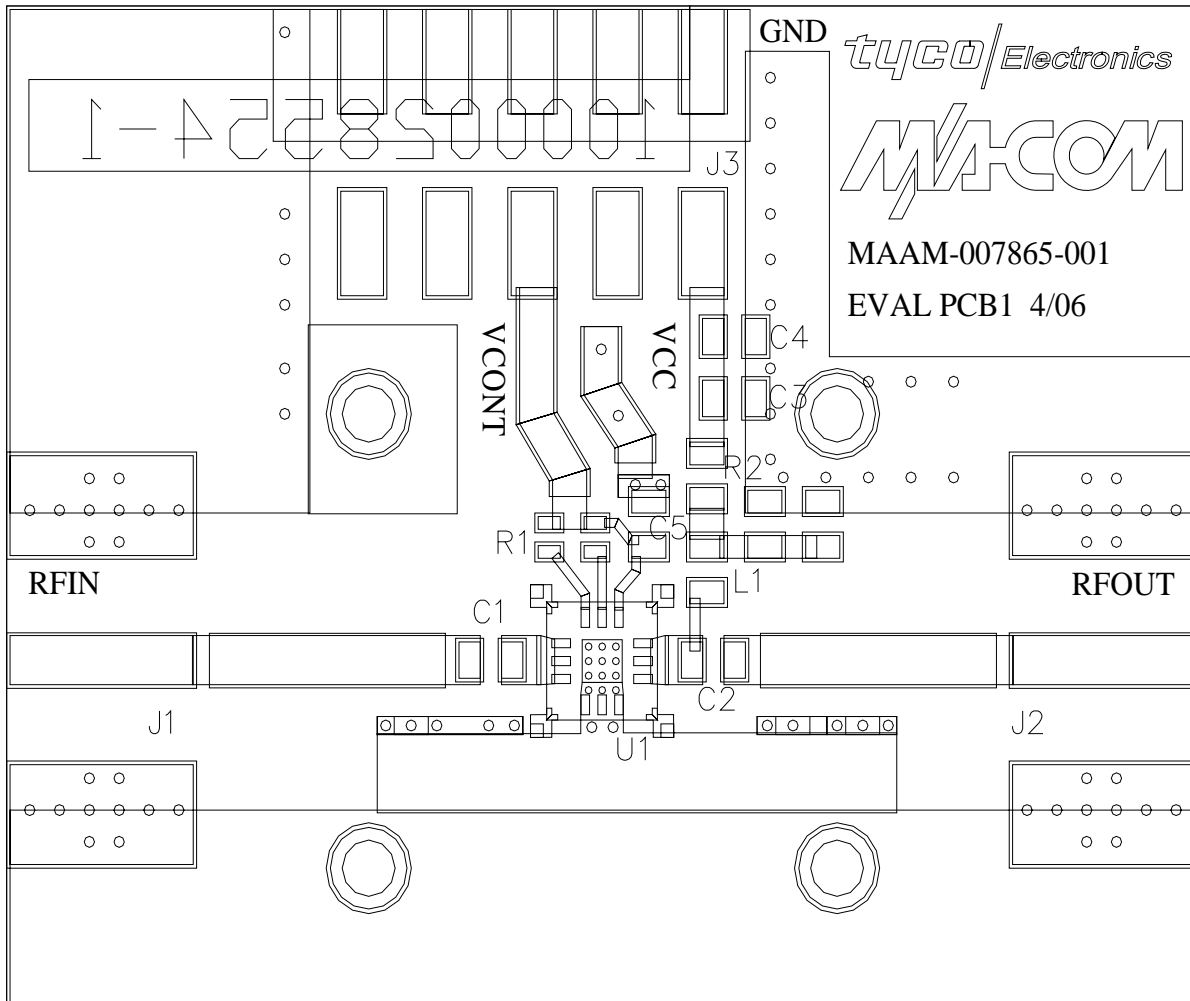

1. GETEK, 2-layer, Total Board Thickness = 32 mil.
Microstrip 50 Ohm Line width = 54 mil
Board Size: 1.4 x 1.1 inches.
2. Via Geometry shown must be used for the 3 mm PQFN package backside to provide a low-inductance & low thermal resistance path to the PCB backside ground.
At least 9 vias are required. Via Diameter = 8 mils finished size with 1.0 mils minimum plating.
3. Evaluation circuit board assemblies use SnPb (tin lead) soldering process to attach all components, and are therefore not RoHS compliant.

Lead-Free 3 mm 12-Lead PQFN Package Outline Dimensions

