

SKY65256-11: WLAN 802.11a, b, g, n Dual-Band, Front-End Module Single Antenna

Features

- 2.4 to 2.5 GHz and 4.9 to 5.9 GHz Operation
- Cardbus, mini PCI, PCIe and AP applications
- P_{OUT} @ 3.0% EVM (OFDM54):
16 dBm (a), 21 dBm (b), 18 dBm (g)
- Gain: 24 dB (a), 27 dB (b,g)
- Integrated PA, filters, directional detector and SPDT switch
- Single supply voltage : 3.0 to 3.6 V
- Single antenna
- Small, ultra thin package 5 x 6 x 0.9 mm
- Lead (Pb)-free and RoHS-compliant

Description

The SKY65256-11 FEM contains one complete dual-band transmit/receive chain in a compact RF front-end module. It includes one 5 GHz PA and one 2 GHz PA each with integrated input filtering for 3–4 GHz rejection, and temperature-compensated directional power detector with 20 dB dynamic range. Also included are low loss, high rejection diplexers and a diversity switch which provide high linearity in transmit and low loss in receive paths. All RF ports are matched to 50 Ω.

The SKY65256-11 is packaged in a lead (Pb)-free, RoHS-compliant laminate package, which measures 30 mm².

NEW

Skyworks offers lead (Pb)-free, RoHS (Restriction of Hazardous Substances)-compliant packaging.



Functional Block Diagram

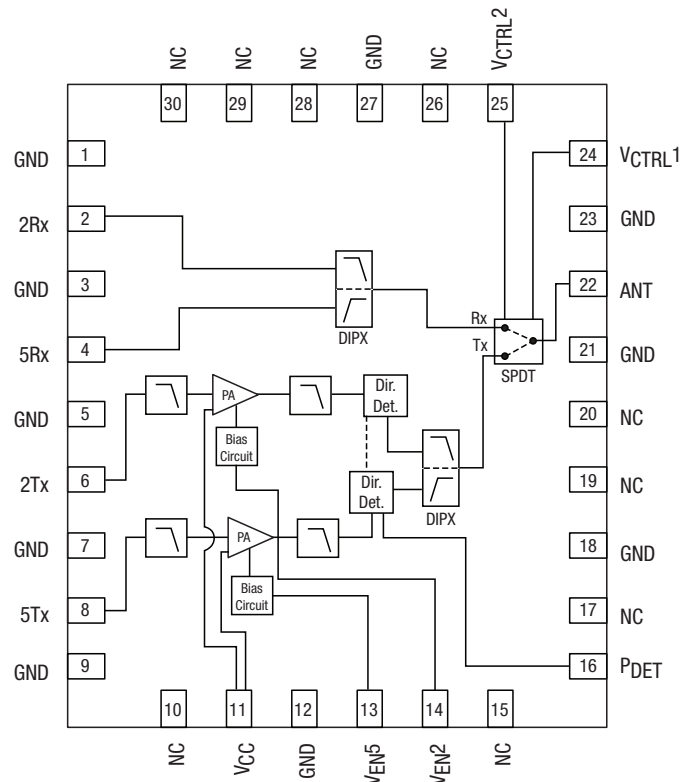

Absolute Maximum Ratings

Parameter	Symbol	Condition	Min.	Typ.	Max.	Unit
V _{CC}	V _{CC}		-0.3		5.5	V
V _{EN2} , V _{EN5}			-0.3		3.6	V
2Tx, 5Tx					10	dBm
Operating temperature range	T _{OP}		-20		85	°C
Storage temperature range	T _{STO}		-65		150	°C

Performance is guaranteed only under the conditions listed in the specifications table and is not guaranteed under the full range(s) described by the Absolute Maximum specifications. Exceeding any of the absolute maximum/minimum specifications may result in permanent damage to the device and will void the warranty.

Recommended Operating Conditions

Parameter	Symbol	Condition	Min.	Typ.	Max.	Unit
Supply voltage	V _{CC}		3	3.3	3.6	V
Reference voltage	V _{EN2} , V _{EN5}		2.8	2.9	3.0	V
Operating temperature	T _{OP}		-10	25	85	°C

DC Characteristics

Conditions: V_{CC} = 3.3 V, T_{OP} = 25 °C. Measurements made on Skyworks EVB with all losses de-embedded. All unused ports terminated into 50 Ω unless otherwise specified.

Parameter	Symbol	Condition	Min.	Typ.	Max.	Unit
Total 802.11g Tx supply current	I _{CC-g}	P _{OUT} = 18 dBm, 54 Mbps OFDM, V _{EN2} = 2.9 V, V _{CC} = 3.3 V V _{EN5} = 0 V		180		mA
Total 802.11g Tx quiescent current	I _{CQ-g}	No RF		95		mA
Total 802.11b Tx supply current	I _{CC-b}	P _{OUT} = 20 dBm, 11 Mbps CCK V _{EN2} = 2.9 V, V _{CC} = 3.3 V V _{EN5} = 0 V		220		mA
Total 802.11a Tx supply current, T0a or T1a	I _{CC-a}	P _{OUT} = 15 dBm, 54 Mbps OFDM, V _{EN5} = 2.9 V, V _{CC} = 3.3 V V _{EN2} = 0 V		170		mA
Total 802.11a Tx quiescent current, T0g or T1g	I _{CQ-a}	No RF		130		mA

PA Logic Characteristics

Conditions: V_{CC} = 3.3 V, T_{OP} = 25 °C. Measurements made on Skyworks EVB with all losses de-embedded. All unused ports terminated into 50 Ω unless otherwise specified.

Parameter	Symbol	Condition	Min.	Typ.	Max.	Unit
Reference voltage high		V _{EN2} , V _{EN5}	2.8	2.9	3.0	V
Reference voltage low		V _{EN2} , V _{EN5}	0		0.3	V
Reference current high		I _{EN2} , I _{EN5}		5		mA
Reference current low		I _{EN2} , I _{EN5}		20		µA

Switch Characteristics

Conditions: $V_{CC} = 3.3\text{ V}$, $T_{OP} = 25\text{ }^{\circ}\text{C}$. Measurements made on Skyworks EVB with all losses de-embedded.
All unused ports terminated into $50\ \Omega$ unless otherwise specified.

Parameter	Symbol	Condition	Min.	Typ.	Max.	Unit
Control voltage - ON state	V_{CTL_on}		3	3.3	3.6	V
Control voltage - OFF state	V_{CTL_off}		0		0.2	V
Control current - ON state	I_{CTL_on}	RF ON		10	75	μA
Control current - ON state	I_{CTL_on}	RF OFF		2	20	μA

Truth Table

Mode	$V_{CTRL1}\text{ (V)}$	$V_{CTRL2}\text{ (V)}$	$V_{EN5}\text{ (V)}$	$V_{EN2}\text{ (V)}$	$V_{CC}\text{ (V)}$
5Tx to ANT	0	3	2.9	0	3.3
2Tx to ANT	0	3	0	2.9	3.3
ANT to 5Rx	3	0	0	0	3.3
ANT to 2Rx	3	0	0	0	3.3

CAUTION: Although this device is designed to be as robust as possible, Electrostatic Discharge (ESD) can damage this device. This device must be protected at all times from ESD. Static charges may easily produce potentials of several kilovolts on the human body or equipment, which can discharge without detection. Industry-standard ESD precautions should be employed at all times.

802.11b,g Transmit Specifications

Conditions: $V_{CC} = 3.3\text{ V}$, $T_{OP} = 25\text{ }^{\circ}\text{C}$. PA enables and control voltages set according to Truth Table. Measurements made on Skyworks EVB with all losses de-embedded. All unused ports terminated into $50\text{ }\Omega$ unless otherwise specified.

Parameter	Symbol	Condition	Min.	Typ.	Max.	Unit
Frequency range	F		2.4		2.5	GHz
Linear output power - g	Plin_g	54 Mbps OFDM, 64 QAM, EVM = 3.0 %		18		dBm
Compliant output power - b	P _{OUT_b}	11 Mbps CCK		21		dBm
1 dB compression point	P _{1 dB}		22.5	25		dBm
Small signal gain	IS ₂₁ I			27		dB
Small signal gain variation over frequency band	Δ IS ₂₁ I			2		dB
Gain, 3.2–3.3 GHz	IS ₂₁ I - 3.2			0		dB
Gain, 1.6 GHz	IS ₂₁ I - 1.6			15		dB
Harmonics	2f, 3f	P _{OUT} = 18 dBm, 1 Mbps, CCK, 802.11b		-50	-42	dBm/MHz
Tx switching time	t _{sw}	50 % of V _{CTL} to 90/10 % RF output			500	ns
Input return loss	IS ₁₁ I			-10		dB
Output return loss	IS ₂₂ I			-8		dB
Stability	STAB	P _{OUT} ≤ 18 dBm, load VSWR = 3:1	All non-harmonically related outputs less than -50 dBc/1 MHz			

802.11b,g Receive Specifications

Conditions: $V_{CC} = 3.3\text{ V}$, $T_{OP} = 25\text{ }^{\circ}\text{C}$. PA enables and control voltages set according to Truth Table. Measurements made on Skyworks EVB with all losses de-embedded. All unused ports terminated into $50\text{ }\Omega$ unless otherwise specified.

Parameter	Symbol	Condition	Min.	Typ.	Max.	Unit
Frequency range	F		2.4		2.5	GHz
Insertion loss	IS ₂₁ I			1.6	2.2	dB
Input/output return loss	IS ₁₁ I, IS ₂₂ I			-15		dB
Antenna to Rx isolation		PA off		23		dB

802.11b,g Power Detector Specification

Conditions: $V_{CC} = 3.3\text{ V}$, $T_{OP} = 25\text{ }^{\circ}\text{C}$. PA enables and control voltages set according to Truth Table. Measurements made on Skyworks EVB with all losses de-embedded. All unused ports terminated into $50\text{ }\Omega$ unless otherwise specified.

Parameter	Symbol	Condition	Min.	Typ.	Max.	Unit
Power detect range	PDR	Ant 0 or Ant 1	5		22	dBm
Power detector accuracy	PDacc2	Over 3:1 VSWR		±1		dB
Voltage limits		Over power range	0.1		1.1	V
Voltage range				0.6		V
Power detector -3 dB corner frequency	LPF-3 dB	10 k Ω load	270	300	400	kHz

802.11a Transmit Specifications

Conditions: $V_{CC} = 3.3\text{ V}$, $T_{OP} = 25\text{ }^{\circ}\text{C}$. PA enables and control voltages set according to Mode Control Voltage table. Measurements made on Skyworks EVB with all losses de-embedded. All unused ports terminated into $50\ \Omega$ unless otherwise specified.

Parameter	Symbol	Condition	Min.	Typ.	Max.	Unit
Frequency range	F		4.9		5.85	GHz
Linear output power - a	Plin_a	54 Mbps OFDM, 64 QAM, EVM = 3.0 %		16		dBm
1 dB compression point	P _{1 dB}		21.5	24		dBm
Small signal gain	S ₂₁			25		dB
Small signal gain variation over any 20 MHz band	$\Delta S_{21} $			2		dB
Gain, 7.25 GHz	S ₂₁ - 7.25			7		dB
Gain, 3.2–3.9 GHz	S ₂₁ - 3.9			0		dB
Gain, 1.6 GHz	S ₂₁ - 1.6			5		dB
Harmonics	2f, 3f	P _{OUT} = 15 dBm, 54 Mbps OFDM		-50	-42	dBm/MHz
Tx switching time	t _{sw}	50 % of V _{CTL} to 90/10 % RF output power level			500	nS
Input return loss	S ₁₁			-6		dB
Output return loss	S ₂₂			-10		dB
Stability	STAB	P _{OUT} ≤ 15 dBm, load VSWR = 3:1	All non-harmonically related outputs less than -50 dBc/1 MHz			

802.11a Receive Specifications (Rx Chain 0, Rx Chain 1)

Conditions: $V_{CC} = 3.3\text{ V}$, $T_{OP} = 25\text{ }^{\circ}\text{C}$. PA enables and control voltages set according to Mode Control Voltage table. Measurements made on Skyworks EVB with all losses de-embedded. All unused ports terminated into $50\ \Omega$ unless otherwise specified.

Parameter	Symbol	Condition	Min.	Typ.	Max.	Unit
Frequency range	F		4.9		5.85	GHz
Insertion loss	S ₂₁			2.5	3	dB
Input/output return loss	S ₁₁ , S ₂₂			-15		dB
Antenna to Rx isolation	S ₂₂	PA off	55			dB

802.11a Power Detector Specification

Conditions: $V_{CC} = 3.3\text{ V}$, $T_{OP} = 25\text{ }^{\circ}\text{C}$. PA enables and control voltages set according to Mode Control Voltage table. Measurements made on Skyworks EVB with all losses de-embedded. All unused ports terminated into $50\ \Omega$ unless otherwise specified.

Parameter	Symbol	Condition	Min.	Typ.	Max.	Unit
Power detect range	PDR	Ant 0 or Ant 1	5		22	dBm
Power detector accuracy	PDacc2	Over 3:1 VSWR		±1		dB
Voltage limits		Over power range	0.1		1.1	V
Voltage range				0.6		V
Power detector -3 dB corner frequency	LPF-3 dB	10 k Ω load	270	300	400	kHz

Typical Performance Data (2.4–2.5 GHz)

V_{CC} = 3.3 V, T_A = 25 °C, OFDM 54 Mbps, Z₀ = 50 Ω, unless otherwise noted

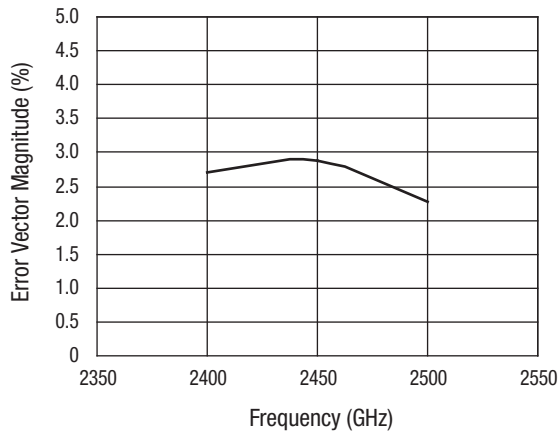

EVM vs. Frequency

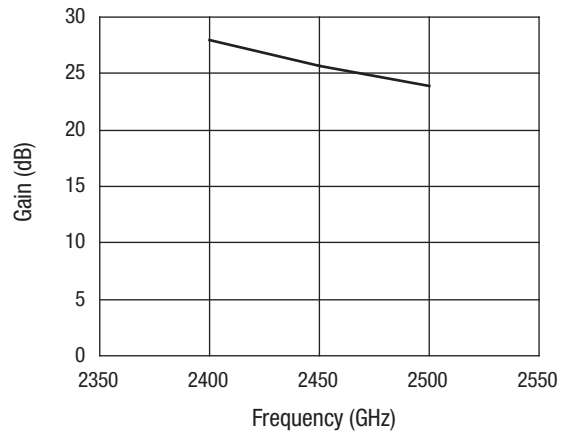

Gain vs. Frequency

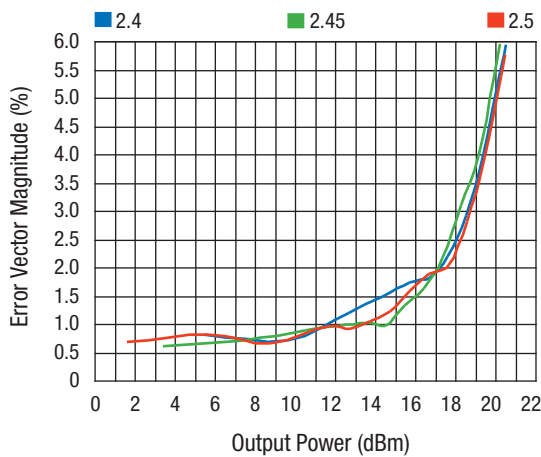

EVM vs. Output Power

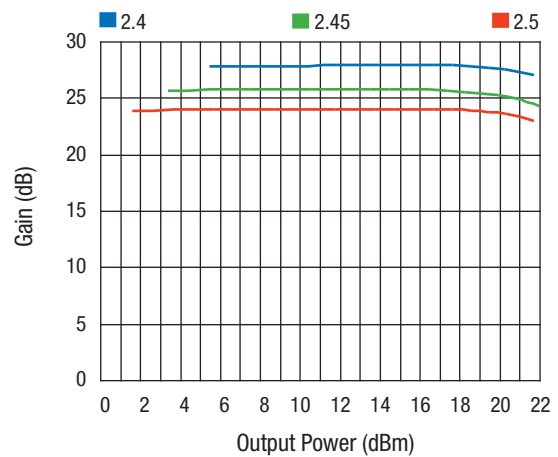

Gain vs. Output Power

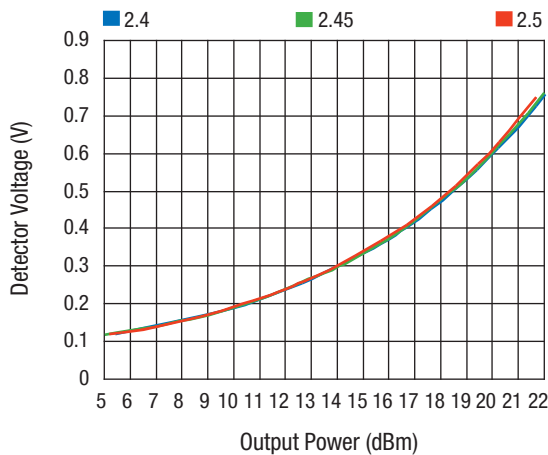

Detector Voltage vs. Output Power

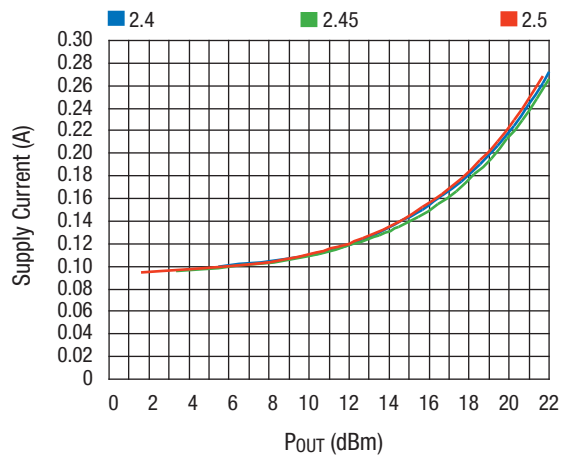

Supply Current vs. Output Power

Typical Performance Data (4.9–5.85 GHz)

$V_{CC} = 3.3\text{ V}$, $T_A = 25\text{ }^\circ\text{C}$, OFDM 54 Mbps, $Z_0 = 50\text{ }\Omega$, unless otherwise noted

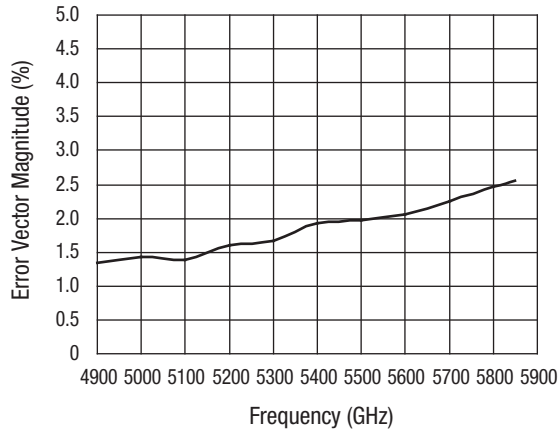

EVM vs. Frequency

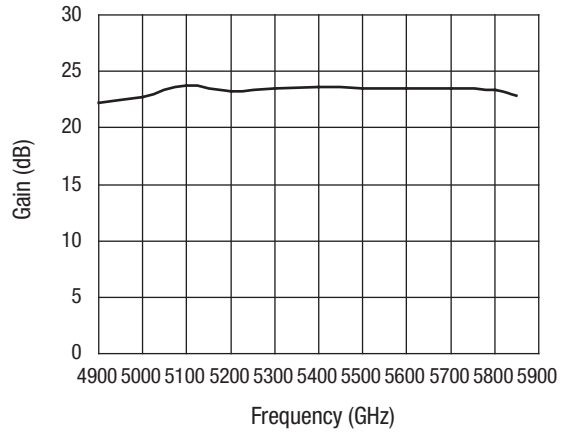

Gain vs. Frequency

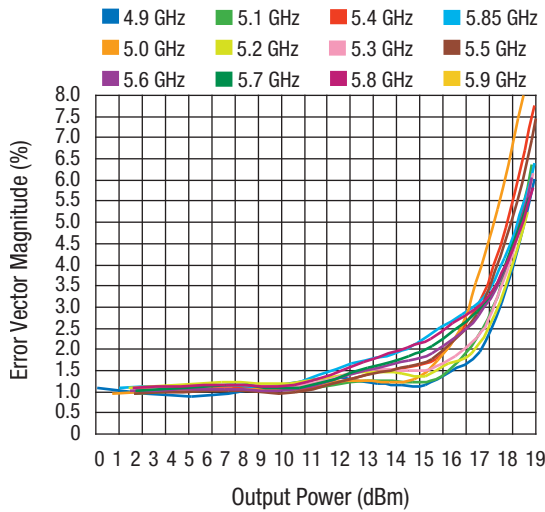

EVM vs. Output Power

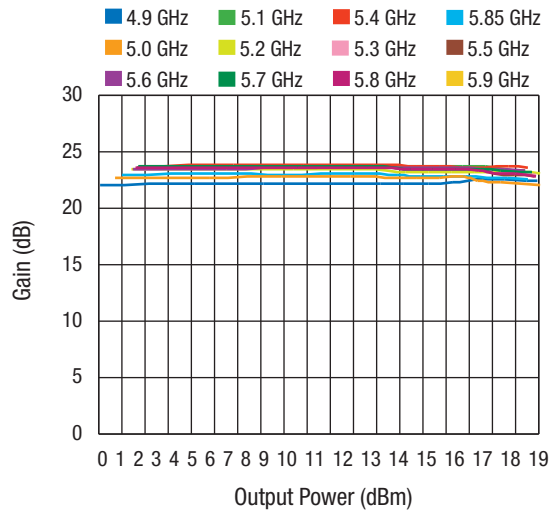

Gain vs. Output Power

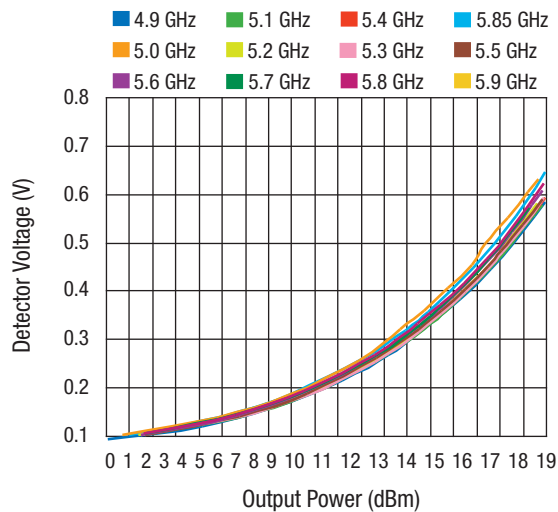

Detector Voltage vs. Output Power

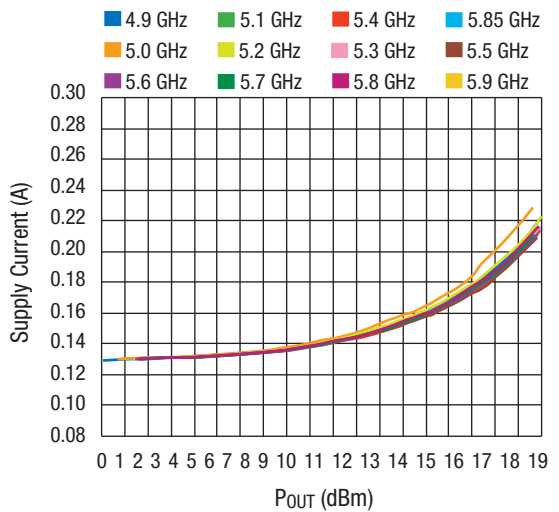

Supply Current vs. Output Power

Pin Out (Top View)

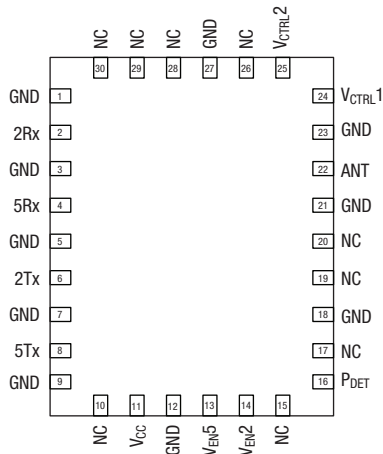

Pin Descriptions

Pin Number	Symbol	Description
1	GND	Ground
2	2Rx	Low-band receive output port. Internally matched to 50 Ω and DC blocked. No external DC block required.
3	GND	Ground
4	5Rx	High-band receive output port. Internally matched to 50 Ω and DC blocked. No external DC block required.
5	GND	Ground
6	2Tx	Low-band transmit input port. Internally matched to 50 Ω and DC blocked. No external DC block required.
7	GND	Ground
8	5Tx	High-band transmit input port. Internally matched to 50 Ω f and DC blocked. No external DC block required.
9	GND	Ground
10	NC	No connection inside the module.
11	VCC	Power supply 3.3 V
12	GND	Ground
13	VEN5	External reference voltage for the high-band PA.
14	VEN2	External reference voltage for the low-band PA.
15	NC	No connection inside the module.
16	PDET	Directional power detector output.
17	NC	No connection inside the module.
18	GND	Ground
19	NC	No connection inside the module.
20	NC	No connection inside the module.
21	GND	Ground
22	Ant	Antenna RF port. Internally matched to 50 Ω. External DC block required.
23	GND	Ground
24	VCTL1	Digital control input for SPDT switch
25	VCTL2	Digital control input for SPDT switch
26	GND	Ground
27	GND	Ground
28	NC	No connection inside the module.
29	NC	No connection inside the module.
30	NC	No connection inside the module.

Application Circuit

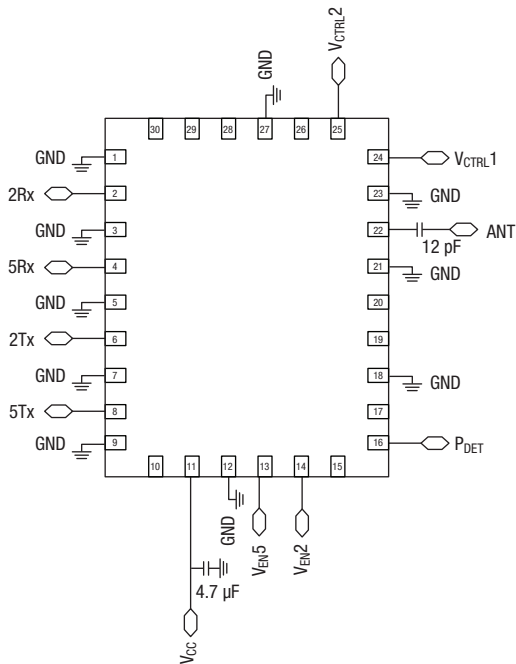

Branding Specifications

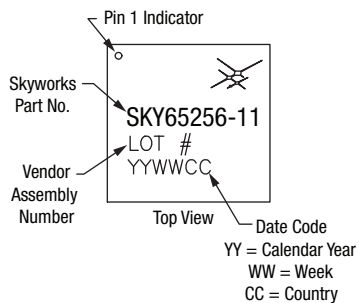

Package Dimensions

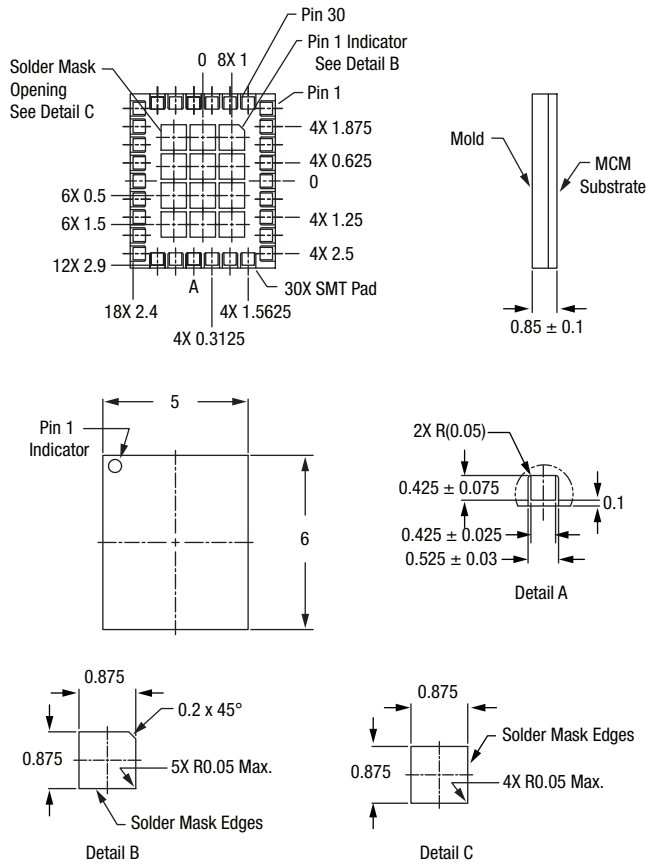

Recommended Solder Reflow Profiles

Refer to the [“Recommended Solder Reflow Profile”](#) Application Note.

Tape and Reel Information

Refer to the [“Discrete Devices and IC Switch/Attenuators Tape and Reel Package Orientation”](#) Application Note.

Copyright © 2006, 2007, Skyworks Solutions, Inc. All Rights Reserved.

Information in this document is provided in connection with Skyworks Solutions, Inc. ("Skyworks") products or services. These materials, including the information contained herein, are provided by Skyworks as a service to its customers and may be used for informational purposes only by the customer. Skyworks assumes no responsibility for errors or omissions in these materials or the information contained herein. Skyworks may change its documentation, products, services, specifications or product descriptions at any time, without notice. Skyworks makes no commitment to update the materials or information and shall have no responsibility whatsoever for conflicts, incompatibilities, or other difficulties arising from any future changes.

No license, whether express, implied, by estoppel or otherwise, is granted to any intellectual property rights by this document. Skyworks assumes no liability for any materials, products or information provided hereunder, including the sale, distribution, reproduction or use of Skyworks products, information or materials, except as may be provided in Skyworks Terms and Conditions of Sale.

THE MATERIALS, PRODUCTS AND INFORMATION ARE PROVIDED "AS IS" WITHOUT WARRANTY OF ANY KIND, WHETHER EXPRESS, IMPLIED, STATUTORY, OR OTHERWISE, INCLUDING FITNESS FOR A PARTICULAR PURPOSE OR USE, MERCHANTABILITY, PERFORMANCE, QUALITY OR NON-INFRINGEMENT OF ANY INTELLECTUAL PROPERTY RIGHT; ALL SUCH WARRANTIES ARE HEREBY EXPRESSLY DISCLAIMED. SKYWORKS DOES NOT WARRANT THE ACCURACY OR COMPLETENESS OF THE INFORMATION, TEXT, GRAPHICS OR OTHER ITEMS CONTAINED WITHIN THESE MATERIALS. SKYWORKS SHALL NOT BE LIABLE FOR ANY DAMAGES, INCLUDING BUT NOT LIMITED TO ANY SPECIAL, INDIRECT, INCIDENTAL, STATUTORY, OR CONSEQUENTIAL DAMAGES, INCLUDING WITHOUT LIMITATION, LOST REVENUES OR LOST PROFITS THAT MAY RESULT FROM THE USE OF THE MATERIALS OR INFORMATION, WHETHER OR NOT THE RECIPIENT OF MATERIALS HAS BEEN ADVISED OF THE POSSIBILITY OF SUCH DAMAGE.

Skyworks products are not intended for use in medical, lifesaving or life-sustaining applications, or other equipment in which the failure of the Skyworks products could lead to personal injury, death, physical or environmental damage. Skyworks customers using or selling Skyworks products for use in such applications do so at their own risk and agree to fully indemnify Skyworks for any damages resulting from such improper use or sale.

Customers are responsible for their products and applications using Skyworks products, which may deviate from published specifications as a result of design defects, errors, or operation of products outside of published parameters or design specifications. Customers should include design and operating safeguards to minimize these and other risks. Skyworks assumes no liability for applications assistance, customer product design, or damage to any equipment resulting from the use of Skyworks products outside of stated published specifications or parameters.

Skyworks, the Skyworks symbol, and "Breakthrough Simplicity" are trademarks or registered trademarks of Skyworks Solutions, Inc., in the United States and other countries. Third-party brands and names are for identification purposes only, and are the property of their respective owners. Additional information, including relevant terms and conditions, posted at www.skyworksinc.com, are incorporated by reference.