

SKY65243-11: WLAN 802.11a, b, g, n Dual-Band, Intera™ Front-End Module Dual Antennas

Features

- 2.4 to 2.5 GHz and 4.9 to 5.9 GHz Operation
- Cardbus, mini PCI, PCIe and AP applications
- P_{OUT} @ 3.0% EVM (OFDM54):
16 dBm (a), 21 dBm (b), 18 dBm (g)
- Gain: 27 dB
- Integrated PA, filters, directional detector and diversity switch
- Single supply voltage : 3.0 to 3.6 V
- Dual antennas
- Small, ultra thin package 5 x 5 x 0.9 mm
- Lead (Pb)-free and RoHS-compliant

Description

The SKY65243-11 Intera FEM contains one complete dual-band transmit/receive chain in a compact RF front-end module. It includes one 5 GHz PA and one 2 GHz PA each with integrated input filtering for 3–4 GHz rejection, and temperature-compensated directional power detector with 20 dB dynamic range. Also included are low loss, high rejection diplexers and a diversity switch which provide high linearity in transmit and low loss in receive paths. All RF ports are matched to 50 Ω .

The SKY65243-11 is packaged in a lead (Pb)-free, RoHS-compliant laminate package, which measures 25 mm².

NEW

Skyworks offers lead (Pb)-free, RoHS (Restriction of Hazardous Substances)-compliant packaging.



Functional Block Diagram

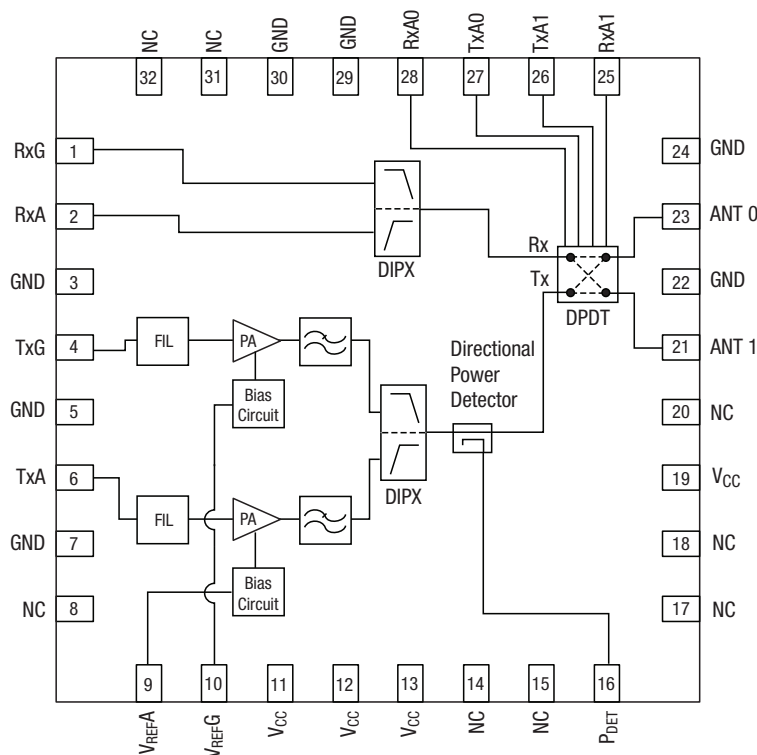

Absolute Maximum Ratings

Parameter	Symbol	Condition	Min.	Typ.	Max.	Unit
Supply voltage	V_{CC}		-0.3		5.5	V
Reference voltage	V_{REFG}, V_{REFA}		-0.3		3.6	V
Supply current	I_{CC}				400	mA
Input power	T_{xG}, T_{xA}				10	dBm
Dissipated power	P_O			0.6	1.0	W
Thermal resistance	θ_{JC}				55	°C/W
Moisture sensitivity level	MSL-3				250	°C
Operating temperature range	T_{OP}		-20		85	°C
Storage temperature range	T_{STO}		-65		150	°C

Performance is guaranteed only under the conditions listed in the specifications table and is not guaranteed under the full range(s) described by the Absolute Maximum specifications. Exceeding any of the absolute maximum/minimum specifications may result in permanent damage to the device and will void the warranty.

Recommended Operating Conditions

Parameter	Symbol	Condition	Min.	Typ.	Max.	Unit
Supply voltage	V_{CC}		3	3.3	3.6	V
Reference voltage	V_{REFG}		2.8	2.9	3.0	V
Operating temperature	T_{OP}		-10	25	85	°C

DC Characteristics

Conditions: $V_{CC} = 3.3$ V, $T_{OP} = 25$ °C. Measurements made on Skyworks EVB with all losses de-embedded. All unused ports terminated into 50 Ω unless otherwise specified.

Parameter	Symbol	Condition	Min.	Typ.	Max.	Unit
Total 802.11g Tx supply current	I_{CC-g}	$P_{OUT} = 18$ dBm, 54 Mbps OFDM, $V_{REFG} = 2.9$ V, $V_{CC} = 3.3$ V $V_{REFA} = 0$ V		180		mA
Total 802.11g Tx quiescent current	I_{CQ-g}	No RF		95		mA
Total 802.11b Tx supply current	I_{CC-b}	$P_{OUT} = 20$ dBm, 11 Mbps CCK $V_{REFG} = 2.9$ V, $V_{CC} = 3.3$ V $V_{REFA} = 0$ V		210		mA
Total 802.11a Tx supply current, T0a or T1a	I_{CC-a}	$P_{OUT} = 15$ dBm, 54 Mbps OFDM, $V_{REFA} = 2.9$ V, $V_{CC} = 3.3$ V $V_{REFG} = 0$ V		180		mA
Total 802.11a Tx quiescent current, T0g or T1g	I_{CQ-a}	No RF		135		mA

PA Logic Characteristics

Conditions: $V_{CC} = 3.3$ V, $T_{OP} = 25$ °C. Measurements made on Skyworks EVB with all losses de-embedded. All unused ports terminated into 50 Ω unless otherwise specified.

Parameter	Symbol	Condition	Min.	Typ.	Max.	Unit
Reference voltage high	V_{REFG-H}		2.8	2.9	3.0	V
Reference voltage low	V_{REFG-L}		0		0.3	V
Reference current high	I_{REFG-H}			5		mA
Reference current low	I_{REFG-L}			20		μ A

Switch Characteristics

**Conditions: $V_{CC} = 3.3\text{ V}$, $T_{OP} = 25\text{ }^{\circ}\text{C}$. Measurements made on Skyworks EVB with all losses de-embedded.
All unused ports terminated into $50\ \Omega$ unless otherwise specified.**

Parameter	Symbol	Condition	Min.	Typ.	Max.	Unit
Control voltage - ON state	V_{CTL_on}		3	3.3	3.6	V
Control voltage - OFF state	V_{CTL_off}		0		0.2	V
Control current - ON state	I_{CTL_on}	RF ON		10	75	μA
Control current - ON state	I_{CTL_on}	RF OFF		2	20	μA

Truth Table

MODE	RxA0 (V)	RxA1 (V)	TxA0 (V)	TxA1 (V)	V_{CC} (V)
Rx-ANT0	3.3	0	0	0	3.3
Rx-ANT1	0	3.3	0	0	3.3
Tx-ANT0	0	0	3.3	0	3.3
Tx-ANT1	0	0	0	3.3	3.3
TxRx-ANT0	3.3	0	3.3	0	3.3

All other combinations undefined.

CAUTION: Although this device is designed to be as robust as possible, Electrostatic Discharge (ESD) can damage this device. This device must be protected at all times from ESD. Static charges may easily produce potentials of several kilovolts on the human body or equipment, which can discharge without detection. Industry-standard ESD precautions should be employed at all times.

802.11b,g Transmit Specifications

Conditions: $V_{CC} = 3.3\text{ V}$, $V_{REFG} = 2.9\text{ V}$, $T_{OP} = 25\text{ }^{\circ}\text{C}$. PA enables and control voltages set according to Truth Table. Measurements made on Skyworks EVB with all losses de-embedded. All unused ports terminated into $50\ \Omega$ unless otherwise specified.

Parameter	Symbol	Condition	Min.	Typ.	Max.	Unit
Frequency range	F		2.4		2.5	GHz
Linear output power - g	P _{lin_g}	54 Mbps OFDM, 64 QAM, EVM = 2.5 %		18		dBm
Compliant output power - b	P _{OUT_b}	11 Mbps CCK		21		dBm
Backed off EVM	BEVM	54 Mbps OFDM, 64 QAM, P _{OUT} = 8 dBm		1.5		%
1 dB compression point	P _{1 dB}		22.5	25		dBm
Small signal gain	S ₂₁			27		dB
Small signal gain variation over frequency band	$\Delta S_{21} $			2		dB
Gain, 3.2–3.3 GHz	S ₂₁ - 3.2			0		dB
Harmonics	2f, 3f	P _{OUT} = 18 dBm, 1 Mbps, CCK, 802.11b		-50	-42	dBm/MHz
Tx switching time	t _{sw}	50 % of V _{CTL} to 90/10 % RF output		1		μs
Input return loss	S ₁₁	TxA or TxG		-10		dB
Output return loss	S ₂₂	Ant0 or Ant1		-8		dB
Stability	STAB	P _{OUT} \leq 18 dBm, load VSWR = 3:1	All non-harmonically related outputs less than -50 dBc/1 MHz			

802.11b,g Receive Specifications

Conditions: $V_{CC} = 3.3\text{ V}$, $V_{REFG} = 2.9\text{ V}$, $T_{OP} = 25\text{ }^{\circ}\text{C}$. PA enables and control voltages set according to Truth Table. Measurements made on Skyworks EVB with all losses de-embedded. All unused ports terminated into $50\ \Omega$ unless otherwise specified.

Parameter	Symbol	Condition	Min.	Typ.	Max.	Unit
Frequency range	F		2.4		2.5	GHz
Insertion loss	S ₂₁			1.1	1.6	dB
Input/output return loss	S ₁₁ , S ₂₂	RxG, Ant 0, 1		-15		dB
Antenna to Rx isolation		PA off, switch in Tx–Ant0 (Ant1) mode		23		dB
Antenna to antenna isolation		Isolation between Ant0 and Ant1 parts Switch in any mode		19		dB

802.11b,g Power Detector Specification

Conditions: $V_{CC} = 3.3\text{ V}$, $V_{REFG} = 2.9\text{ V}$, $T_{OP} = 25\text{ }^{\circ}\text{C}$. PA enables and control voltages set according to Truth Table. Measurements made on Skyworks EVB with all losses de-embedded. All unused ports terminated into $50\ \Omega$ unless otherwise specified.

Parameter	Symbol	Condition	Min.	Typ.	Max.	Unit
Power detect range	PDR	Ant 0 or Ant 1	5		22	dBm
Power detector accuracy	PDacc2	Over 3:1 VSWR		± 1		dB
P _{DET} load impedance				22.5		k Ω
P _{DET} output impedance					3	k Ω
Voltage limits		Over power range	0.1		1.1	V
Voltage range			0.3	0.6		V
Power detector -3 dB corner frequency	LPF-3 dB	10 k Ω load	270	300	400	kHz

802.11a Transmit Specifications

Conditions: $V_{CC} = 3.3$ V, $V_{REFA} = 2.9$ V, $T_{OP} = 25$ °C. PA enables and control voltages set according to Mode Control Voltage table. Measurements made on Skyworks EVB with all losses de-embedded. All unused ports terminated into 50 Ω unless otherwise specified.

Parameter	Symbol	Condition	Min.	Typ.	Max.	Unit
Frequency range	F		4.9		5.85	GHz
Linear output power - a	Plin_a	54 Mbps OFDM, 64 QAM, EVM = 3.0 %		16		dBm
Backed off EVM	BEVM	54 Mbps OFDM, 64 QAM, P _{OUT} = 7 dBm		1.5		%
1 dB compression point	P _{1 dB}		21.5	24		dBm
Small signal gain	IS ₂₁ I			25		dB
Small signal gain variation over any 20 MHz band	Δ IS ₂₁ I			2		dB
Gain matching, T0g to A0 vs. T1g to A1	IS ₂₁ I - M	Compared frequency by frequency		2		dB
Gain, 3.2–3.9 GHz	IS ₂₁ I - 3.9			0		dB
Harmonics	2f, 3f	P _{OUT} = 18 dBm, 1 Mbps, CCK, 802.11b		-50	-42	dBm/MHz
Tx switching time	t _{sw}	50 % of V _{CTL} to 90/10 % RF output power level		0.5		μ s
Input return loss	IS ₁₁ I	TxA or TxG		-6		dB
Output return loss	IS ₂₂ I	Ant 0 or Ant 1		-10		dB
Stability	STAB	P _{OUT} \leq 18 dBm, load VSWR = 3:1	All non-harmonically related outputs less than -50 dBc/1 MHz			

802.11a Receive Specifications

Conditions: $V_{CC} = 3.3$ V, $V_{REFA} = 2.9$ V, $T_{OP} = 25$ °C. PA enables and control voltages set according to Mode Control Voltage table. Measurements made on Skyworks EVB with all losses de-embedded. All unused ports terminated into 50 Ω unless otherwise specified.

Parameter	Symbol	Condition	Min.	Typ.	Max.	Unit
Frequency range	F		4.9		5.85	GHz
Insertion loss	IS ₂₁ I			2.5	3	dB
Input/output return loss	IS ₁₁ I, IS ₂₂ I	RxG–Ant0, 1		-15		dB
Antenna to Rx isolation	IS ₂₁ I	PA off, switch in Tx–Ant0 (Ant1) mode		22		dB
Antenna to antenna isolation	Δ IS ₂₁ I	Isolation between Ant0 and Ant1 paths. Switch in any mode.		19		dB

802.11a Power Detector Specification

Conditions: $V_{CC} = 3.3$ V, $V_{REFA} = 2.9$ V, $T_{OP} = 25$ °C. PA enables and control voltages set according to Mode Control Voltage table. Measurements made on Skyworks EVB with all losses de-embedded. All unused ports terminated into 50 Ω unless otherwise specified.

Parameter	Symbol	Condition	Min.	Typ.	Max.	Unit
Power detect range	PDR	Ant 0 or Ant 1	5		22	dBm
Power detector accuracy	PDacc2	Over 3:1 VSWR		\pm 1		dB
P _{DET} load impedance				22.5		k Ω
P _{DET} output impedance					3	k Ω
Voltage limits		Over power range	0.1		1.1	V
Voltage range			0.3	0.6		V
Power detector -3 dB corner frequency	LPF-3 dB	10 K Ω load	270	300	400	kHz

Pin Out (Top View)

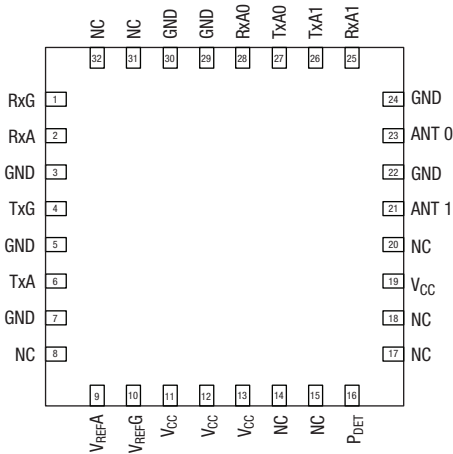

Application Circuit

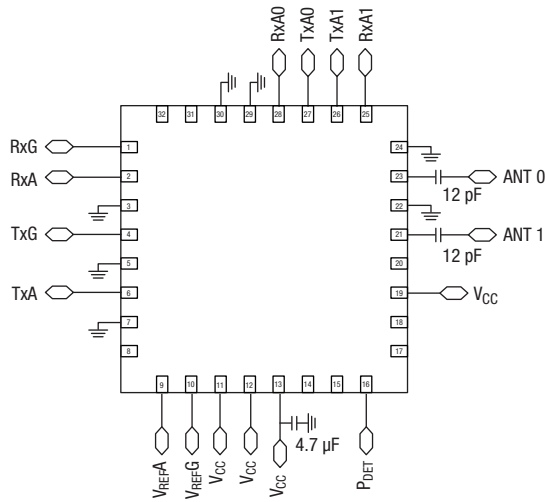

Branding Specifications

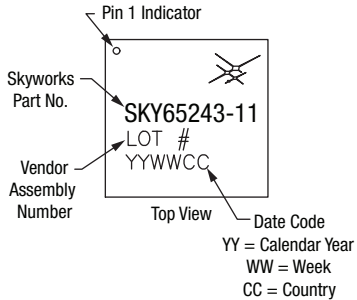

Pin Descriptions

Pin Number	Symbol	Description
1	RxG	Low-band receive output port. Internally matched to 50 Ω and DC blocked.
2	RxA	High-band receive output port. Internally matched to 50 Ω and DC blocked.
3	GND	Ground
4	TxG	Low-band transmit input port. Internally matched to 50 Ω and DC blocked.
5	GND	Ground
6	TxA	High-band transmit input port. Internally matched to 50 Ω and DC blocked.
7	GND	Ground
8	NC	No connection inside the module.
9	VREFA	External reference voltage for the high-band PA.
10	VREFG	External reference voltage for the low-band PA.
11	VCC	Power supply 3.3 V, A band
12	VCC	Power supply 3.3 V, A band
13	VCC	Power supply 3.3 V, A band
14	NC	No connection inside the module.
15	NC	No connection inside the module.
16	PDET	Directional power detector output.
17	NC	No connection inside the module.
18	NC	No connection inside the module.
19	VCC	Power supply 3.3 V, G band
20	NC	No connection inside the module.
21	Ant 1	Auxiliary antenna RF port. Internally matched to 50 Ω. External DC block cap required.
22	GND	Ground
23	Ant 0	Main antenna RF port. Internally matched to 50 Ω. External DC block cap required.
24	GND	Ground
25	RxA1	Digital control input for DPDT switch
26	TxA1	Digital control input for DPDT switch
27	TxAO	Digital control input for DPDT switch
28	RxAO	Digital control input for DPDT switch
29	GND	Ground
30	GND	Ground
31	NC	No connection inside the module.
32	NC	No connection inside the module.

Recommended Footprint

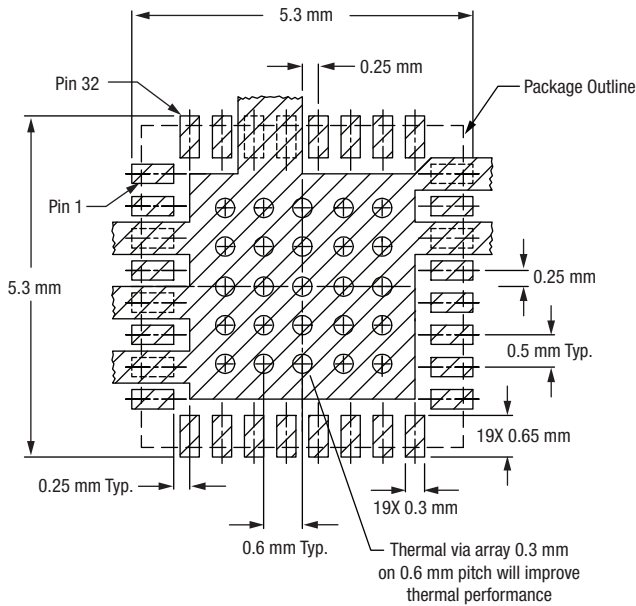

Solder Mask

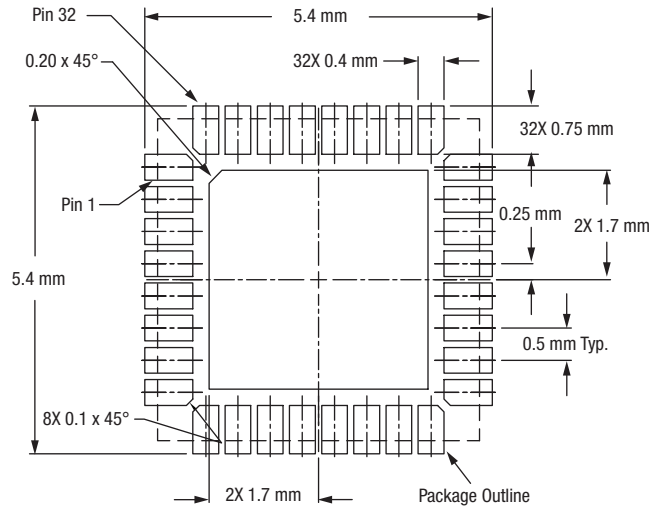

Stencil Pattern

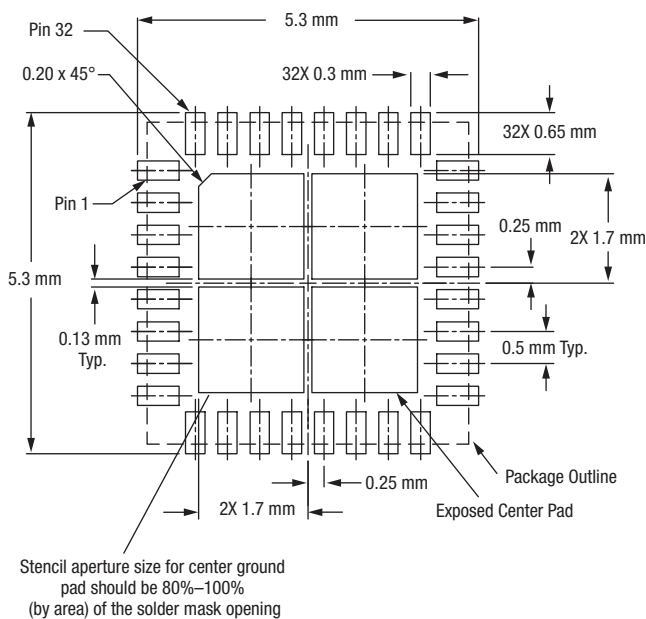

Package Dimensions

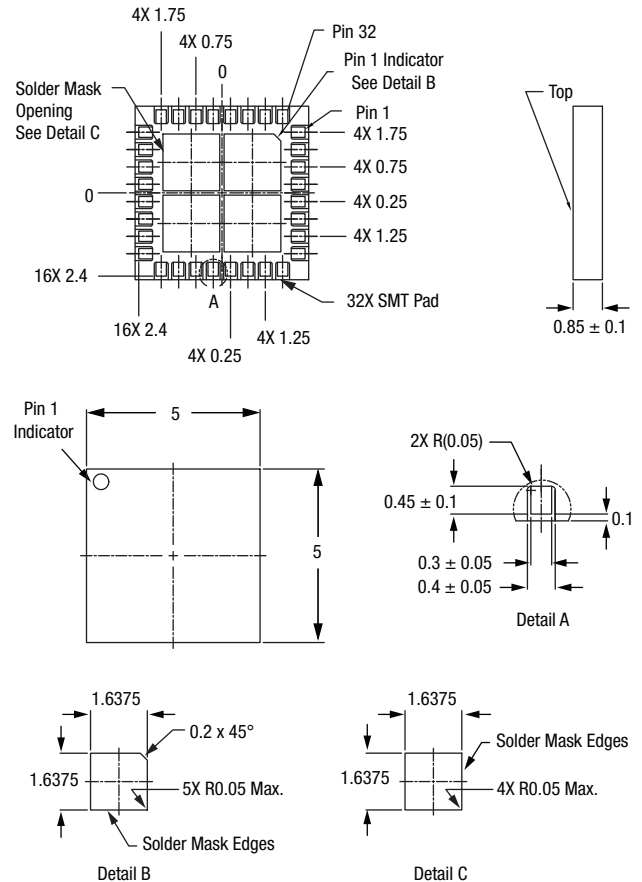

Recommended Solder Reflow Profiles

Refer to the [“Recommended Solder Reflow Profile”](#) Application Note.

Tape and Reel Information

Refer to the [“Discrete Devices and IC Switch/Attenuators Tape and Reel Package Orientation”](#) Application Note.

Copyright © 2006, 2007, 2008, Skyworks Solutions, Inc. All Rights Reserved.

Information in this document is provided in connection with Skyworks Solutions, Inc. ("Skyworks") products or services. These materials, including the information contained herein, are provided by Skyworks as a service to its customers and may be used for informational purposes only by the customer. Skyworks assumes no responsibility for errors or omissions in these materials or the information contained herein. Skyworks may change its documentation, products, services, specifications or product descriptions at any time, without notice. Skyworks makes no commitment to update the materials or information and shall have no responsibility whatsoever for conflicts, incompatibilities, or other difficulties arising from any future changes.

No license, whether express, implied, by estoppel or otherwise, is granted to any intellectual property rights by this document. Skyworks assumes no liability for any materials, products or information provided hereunder, including the sale, distribution, reproduction or use of Skyworks products, information or materials, except as may be provided in Skyworks Terms and Conditions of Sale.

THE MATERIALS, PRODUCTS AND INFORMATION ARE PROVIDED "AS IS" WITHOUT WARRANTY OF ANY KIND, WHETHER EXPRESS, IMPLIED, STATUTORY, OR OTHERWISE, INCLUDING FITNESS FOR A PARTICULAR PURPOSE OR USE, MERCHANTABILITY, PERFORMANCE, QUALITY OR NON-INFRINGEMENT OF ANY INTELLECTUAL PROPERTY RIGHT; ALL SUCH WARRANTIES ARE HEREBY EXPRESSLY DISCLAIMED. SKYWORKS DOES NOT WARRANT THE ACCURACY OR COMPLETENESS OF THE INFORMATION, TEXT, GRAPHICS OR OTHER ITEMS CONTAINED WITHIN THESE MATERIALS. SKYWORKS SHALL NOT BE LIABLE FOR ANY DAMAGES, INCLUDING BUT NOT LIMITED TO ANY SPECIAL, INDIRECT, INCIDENTAL, STATUTORY, OR CONSEQUENTIAL DAMAGES, INCLUDING WITHOUT LIMITATION, LOST REVENUES OR LOST PROFITS THAT MAY RESULT FROM THE USE OF THE MATERIALS OR INFORMATION, WHETHER OR NOT THE RECIPIENT OF MATERIALS HAS BEEN ADVISED OF THE POSSIBILITY OF SUCH DAMAGE.

Skyworks products are not intended for use in medical, lifesaving or life-sustaining applications, or other equipment in which the failure of the Skyworks products could lead to personal injury, death, physical or environmental damage. Skyworks customers using or selling Skyworks products for use in such applications do so at their own risk and agree to fully indemnify Skyworks for any damages resulting from such improper use or sale.

Customers are responsible for their products and applications using Skyworks products, which may deviate from published specifications as a result of design defects, errors, or operation of products outside of published parameters or design specifications. Customers should include design and operating safeguards to minimize these and other risks. Skyworks assumes no liability for applications assistance, customer product design, or damage to any equipment resulting from the use of Skyworks products outside of stated published specifications or parameters.

Skyworks, the Skyworks symbol, and "Breakthrough Simplicity" are trademarks or registered trademarks of Skyworks Solutions, Inc., in the United States and other countries. Third-party brands and names are for identification purposes only, and are the property of their respective owners. Additional information, including relevant terms and conditions, posted at www.skyworksinc.com, are incorporated by reference.