

SKY65119: 700 – 800 MHz Linear Power Amplifier

Applications

- AMPS/CDMA/TDMA/GSM
- Repeaters
- WLL and ISM bands
- Mobile radio
- Paging
- Telematics

Features

- Typical P_{OUT} of 32.5 dBm
- High linearity
- Low power consumption
- Single +5 V supply
- MCM (12-pin, 8 x 8 mm) Pb-free free (MSL3, 250 °C per JEDEC J-STD-020) SMT package

Description

Skyworks SKY65119 Power Amplifier (PA) is a fully matched, 12-pin lead-free Multi-Chip Module (MCM) developed for cellular, Wireless Local Loop (WLL), and Industrial, Scientific, Medical (ISM) applications. This small, power-efficient PA has a full 700 to 800 MHz bandwidth coverage packed into a single compact package.

All active circuitry in the module is contained in a single Gallium Arsenide (GaAs) Microwave Monolithic Integrated Circuit (MMIC). The SKY65119 is manufactured with Skyworks Aluminum (Al) GaAs Heterojunction Bipolar Transistor (HBT) process, which allows for single supply operation while maintaining high efficiency and good linearity.

Figure 1 shows a functional block diagram for the SKY65119. The device package and pinout are shown in Figure 2. Signal pin assignments and functional pin descriptions are provided in Table 1.

NEW Skyworks offers lead (Pb)-free, RoHS (Restriction of Hazardous Substances) compliant packaging.

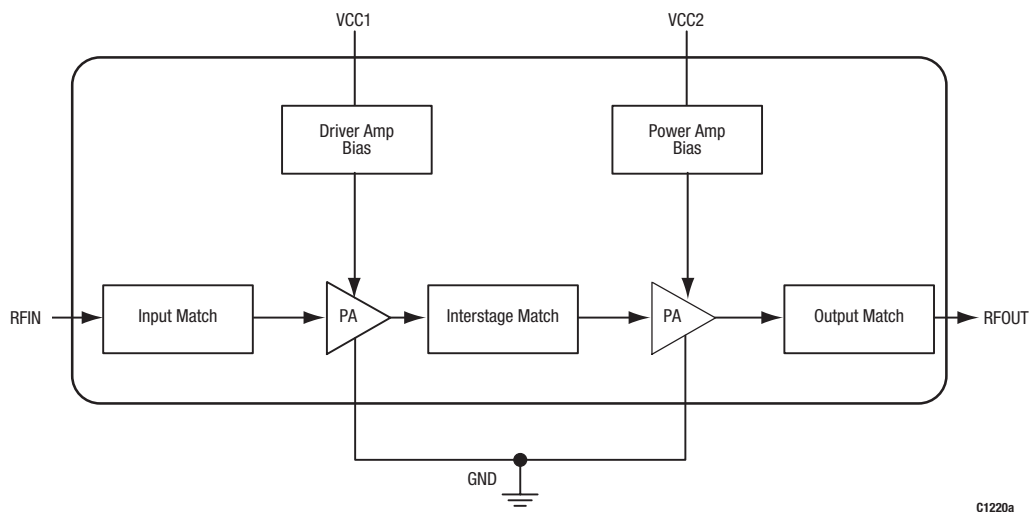

Figure 1. SKY65119 Functional Block Diagram

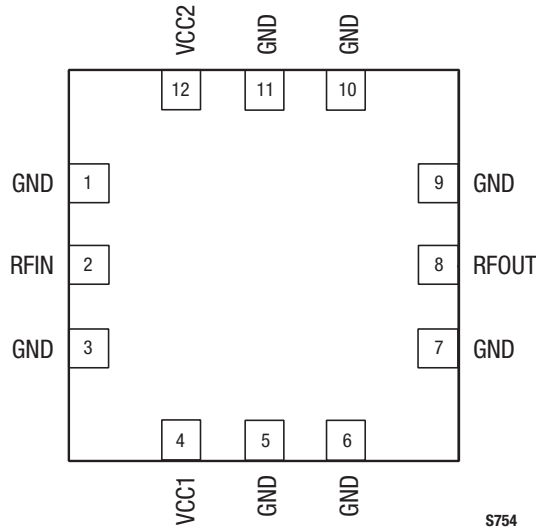

Figure 2. SKY65119 Pinout– 12-Pin MCM Package (Top View)

Table 1. SKY65119 Signal Descriptions

Pin #	Name	Description	Pin #	Name	Description
1	GND	Ground	7	GND	Ground
2	RFIN	RF input	8	RFOUT	RF output
3	GND	Ground	9	GND	Ground
4	VCC1	Supply voltage	10	GND	Ground
5	GND	Ground	11	GND	Ground
6	GND	Ground	12	VCC2	Supply voltage

Technical Description

The SKY65119 is comprised of two amplifier stages. The matching circuits for the input stage, inter-stage, and output stage are contained within the device. The bias circuits for both input and output stages are included within the device for optimum temperature tracking performance.

The SKY65119 is internally matched for optimum linearity and efficiency. The input and output stages are independently supplied using the VCC1 and VCC2 supply lines, pins 4 and 12, respectively.

The SKY65119 is rated to Moisture Sensitivity Level 3 (MSL3) at 250 °C. It can be used for lead or lead-free soldering. For additional information, refer to Skyworks Application Note, *PCB Design and SMT Assembly/Rework Guidelines for MCM-L Packages*, document number 101752.

Care must be taken when attaching this product, whether it is done manually or in a production solder reflow environment. Production quantities of this product are shipped in a standard tape and reel format. For packaging details, refer to the Skyworks Application Note, *Tape and Reel*, document number 101568.

Package and Handling Information

Since the device package is sensitive to moisture absorption, it is baked and vacuum packed before shipping. Instructions on the shipping container label regarding exposure to moisture after the container seal is broken must be followed. Otherwise, problems related to moisture absorption may occur when the part is subjected to high temperature during solder assembly.

Electrical and Mechanical Specifications

The absolute maximum ratings of the SKY65119 are provided in Table 2. The recommended operating conditions are specified in Table 3 and electrical specifications are provided in Table 4.

Typical performance characteristics over temperature of the SKY65119 are illustrated in Figures 3 through 8.

Figure 13 shows the package dimensions for the 12-pin SKY65119 MCM and Figure 14 provides the tape and reel dimensions.

Electrostatic Discharge (ESD) Sensitivity

The SKY65119 is a static-sensitive electronic device. Do not operate or store near strong electrostatic fields. Take proper ESD precautions.

Table 2. SKY65119 Absolute Maximum Ratings

Parameter	Symbol	Min	Typical	Max	Units
RF input power	P_{IN}			0	dBm
Supply voltage (VCC1 and VCC2)	VCC			6	V
Case operating temperature	T_C	-40		+85	°C
Storage temperature	T_{ST}	-55		+125	°C

Note: Exposure to maximum rating conditions for extended periods may reduce device reliability. There is no damage to device with only one parameter set at the limit and all other parameters set at or below their nominal values.

Table 3. SKY65119 Recommended Operating Conditions

Parameter	Symbol	Min	Typical	Max	Units
Supply voltage (VCC1 and VCC2)	VCC		5		V
Operating frequency	F_0	700	750	800	MHz

Table 4. SKY65119 Electrical Characteristics
(VCC = 5.0 V, Frequency = 750 MHz, T_C = 25 °C, unless otherwise noted)

Parameter	Symbol	Test Conditions	Min	Typical	Max	Units
Analog Inputs						
Frequency range			700	750	800	MHz
Quiescent current	I_Q			220	245	mA
Small signal gain	G	$P_{IN} = -15$ dBm	28.5	30.0	31.5	dB
Output power	P_{OUT}	$P_{IN} = 4$ dBm	31.5	32.5		dBm
Efficiency	PAE	$P_{IN} = 4$ dBm	32	35		%
Noise Figure	NF			4.5	6.0	dB
Output IP3	OIP3	Two tones with 100 kHz spacing, $P_{IN} = -6$ dBm per tone	38	42		dBm
P_{OUT} @ ACPR = -45 dBc	P_{OUT_ACPR}	f = 750 MHz, 885 kHz offset	24	26		dBm

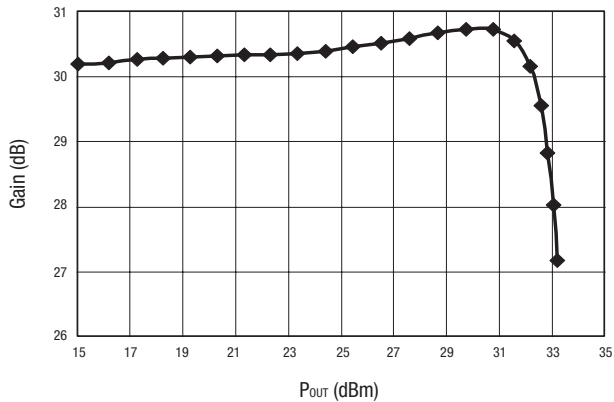

Figure 3. Typical Gain vs P_{OUT} @ 750 MHz

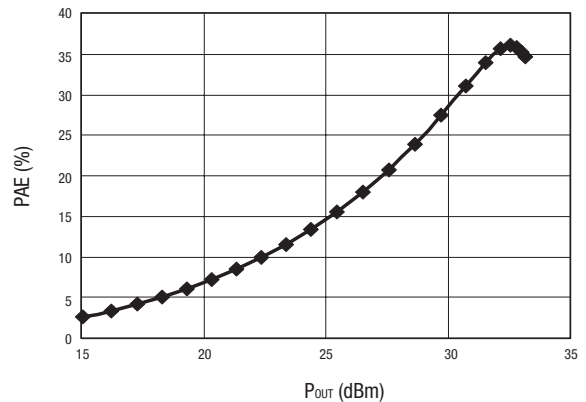

Figure 4. Typical PAE vs P_{OUT} @ 750 MHz

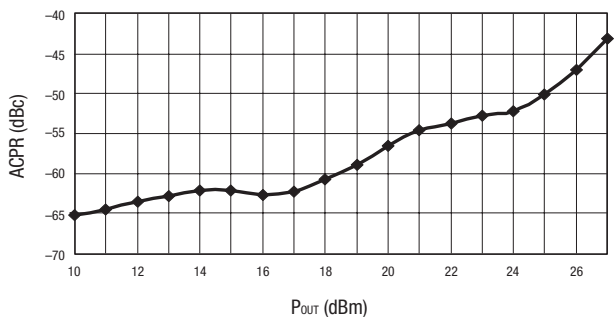

Figure 5. Typical ACPR vs P_{OUT} @ 750 MHz

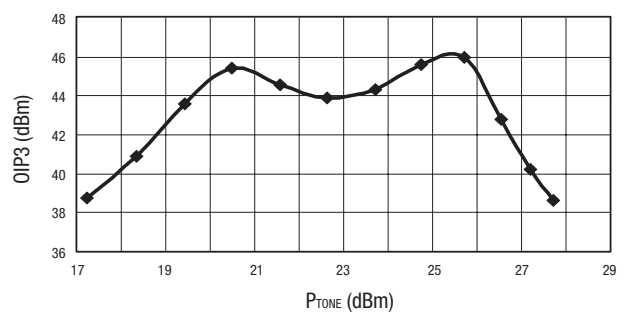

Figure 6. Typical OIP3 vs Output P_{tone}
(F1 = 750 MHz, F2 = 750.1 MHz)

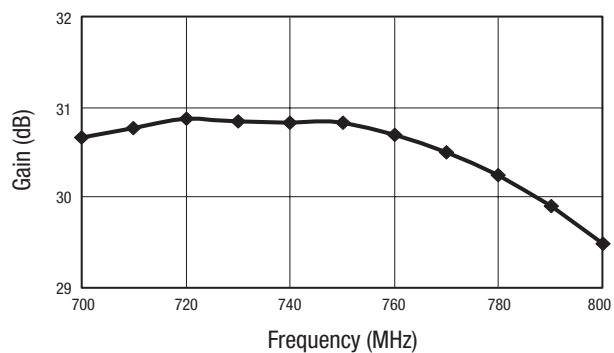

Figure 7. Typical Small Signal Gain vs Frequency

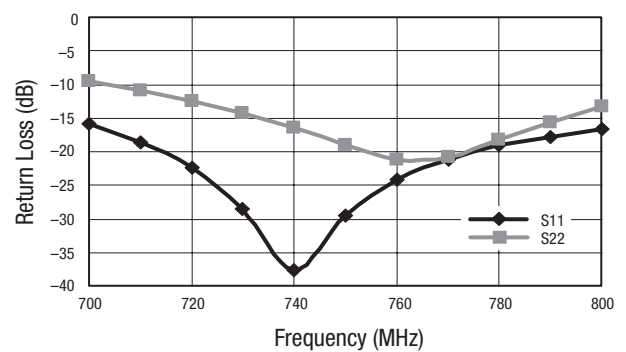

Figure 8. Typical Input and Output Return Loss vs Frequency

Evaluation Board Description

Skyworks SKY65119 Evaluation Board is used to test the performance of the SKY65119 PA. The Evaluation Board schematic diagram is shown in Figure 9. The schematic shows the basic design of the board for the 700 to 800 MHz range. An assembly drawing for the Evaluation Board is shown in Figure 10 and the layer detail is provided in Figure 11.

Circuit Design Considerations

The following design considerations are general in nature and must be followed regardless of final use or configuration

1. Paths to ground should be made as short as possible.
2. The ground pad of the SKY65119 PA has special electrical and thermal grounding requirements. This pad is the main thermal conduit for heat dissipation. Since the circuit board acts as the heat sink, it must shunt as much heat as possible from the amplifier. As such, design the connection to the ground pad to dissipate the maximum wattage produced to the circuit board. Multiple vias to the grounding layer are required.
3. Two external output bypass capacitors (0.01 μF , and 4.7 μF) are required on the VCC1 (pin 4) supply input and also on the VCC2 (pin 12) supply input. All four capacitors should be placed in parallel between the supply line and ground. See Figure 9 for a detailed diagram.
4. VCC2 (pin 12) and VCC1 (pin 4) may be connected together at the supply.

5. The RF output includes an onboard internal DC blocking capacitor. All impedance matching is provided internally. Therefore, the application only needs to provide a good 50 Ω load.

Testing Procedure

Use the following procedure to set up the SKY65119 Evaluation Board for testing. Refer to Figure 12 for guidance:

1. Connect a +5.0 V supply voltage to VCC1 and VCC2. If available, enable the current limiting function of the power supply to 1.0 A.
2. Connect a signal generator to the RF signal input port. Set it to the desired RF frequency at a power level of 4 dBm or less to the Evaluation Board but do NOT enable the RF signal.
3. Connect a spectrum analyzer to the RF signal output port.
4. Enable the power supply.
5. Enable the RF signal.
6. Take measurements.

CAUTION: *If the input signal exceeds the rated power, the SKY65119 Evaluation Board can be permanently damaged.*

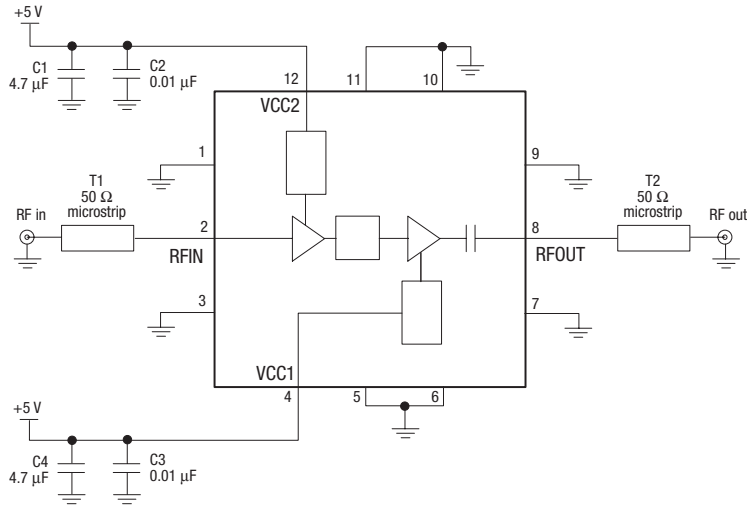

Notes:
 1) The device ground pad provides both a thermal and electrical ground. This ground path is critical and must be as short as possible.
 2) Transmission line lengths T1 and T2 should be minimized.

S755

Figure 9. Evaluation Board Schematic, 700 MHz to 800 MHz

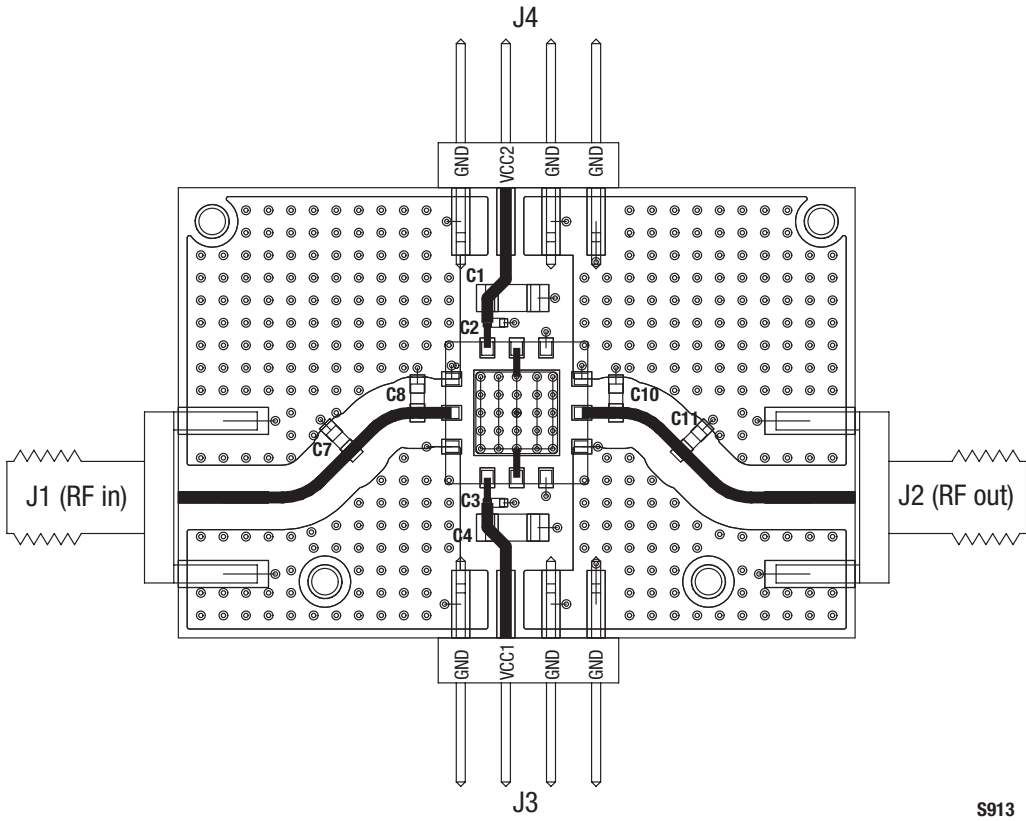

S913

Figure 10. Evaluation Board Assembly Diagram

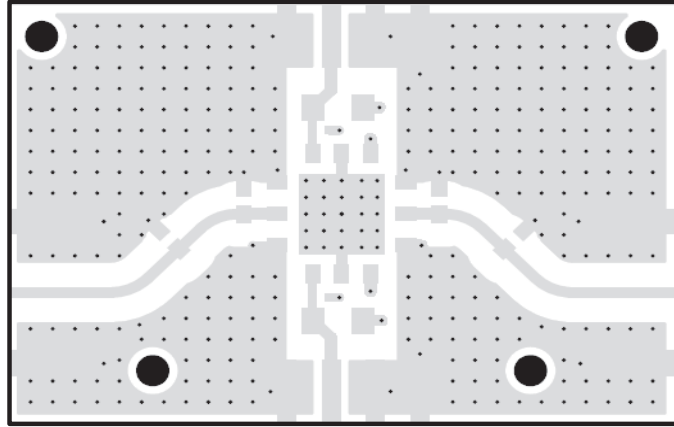

Layer 1: Top Metal

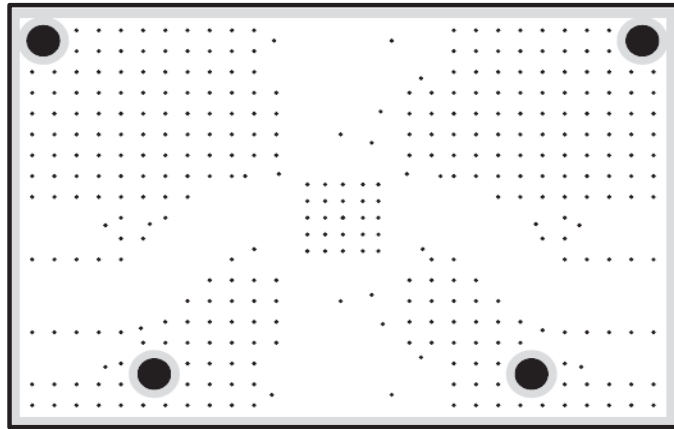

Layer 2: Inner Layer

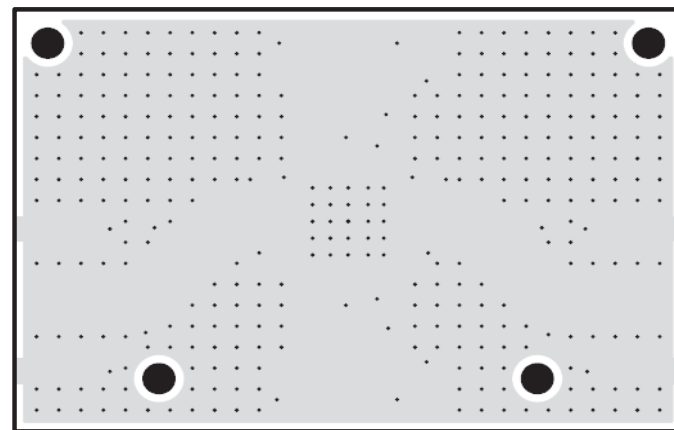

Layer 1: Solid Ground Plane

S914

Figure 11. Evaluation Board Layer Detail

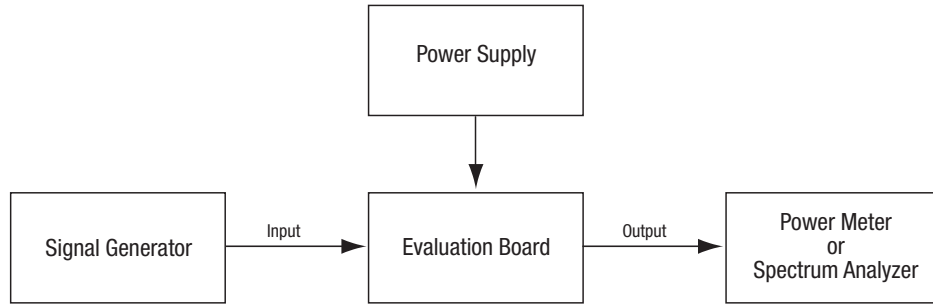

S757

Figure 12. SKY65119 Evaluation Board Testing Configuration

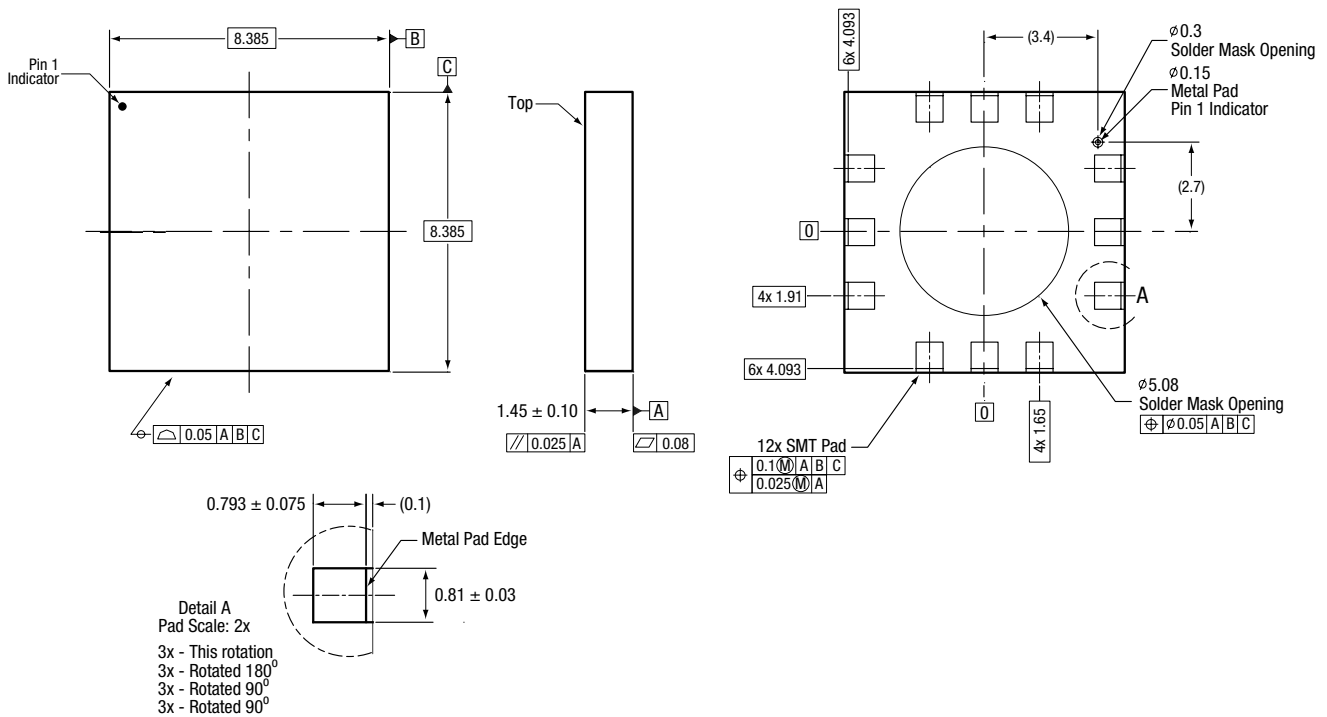

All measurements are in millimeters

S742

Figure 13. SKY65119 12-Pin MCM Package Dimensions

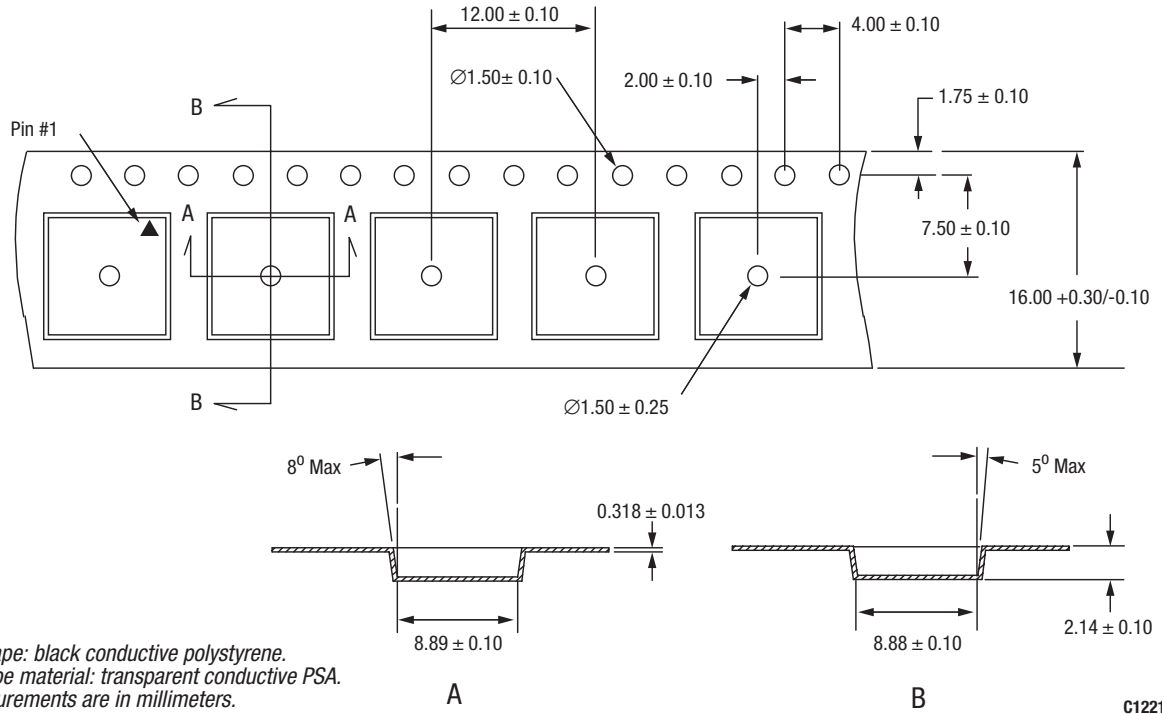

Figure 14. SKY65119 Tape and Reel Dimensions

Ordering Information

Model Name	Manufacturing Part Number	Evaluation Kit Part Number
SKY65119 700-800 MHz Linear Power Amplifier	SKY65119-21 (Pb-free package)	TW16-D182-001

Copyright © 2006, Skyworks Solutions, Inc. All Rights Reserved.

Information in this document is provided in connection with Skyworks Solutions, Inc. (“Skyworks”) products or services. These materials, including the information contained herein, are provided by Skyworks as a service to its customers and may be used for informational purposes only by the customer. Skyworks assumes no responsibility for errors or omissions in these materials or the information contained herein. Skyworks may change its documentation, products, services, specifications or product descriptions at any time, without notice. Skyworks makes no commitment to update the materials or information and shall have no responsibility whatsoever for conflicts, incompatibilities, or other difficulties arising from any future changes.

No license, whether express, implied, by estoppel or otherwise, is granted to any intellectual property rights by this document. Skyworks assumes no liability for any materials, products or information provided hereunder, including the sale, distribution, reproduction or use of Skyworks products, information or materials, except as may be provided in Skyworks Terms and Conditions of Sale.

THE MATERIALS, PRODUCTS AND INFORMATION ARE PROVIDED “AS IS” WITHOUT WARRANTY OF ANY KIND, WHETHER EXPRESS, IMPLIED, STATUTORY, OR OTHERWISE, INCLUDING FITNESS FOR A PARTICULAR PURPOSE OR USE, MERCHANTABILITY, PERFORMANCE, QUALITY OR NON-INFRINGEMENT OF ANY INTELLECTUAL PROPERTY RIGHT; ALL SUCH WARRANTIES ARE HEREBY EXPRESSLY DISCLAIMED. SKYWORKS DOES NOT WARRANT THE ACCURACY OR COMPLETENESS OF THE INFORMATION, TEXT, GRAPHICS OR OTHER ITEMS CONTAINED WITHIN THESE MATERIALS. SKYWORKS SHALL NOT BE LIABLE FOR ANY DAMAGES, INCLUDING BUT NOT LIMITED TO ANY SPECIAL, INDIRECT, INCIDENTAL, STATUTORY, OR CONSEQUENTIAL DAMAGES, INCLUDING WITHOUT LIMITATION, LOST REVENUES OR LOST PROFITS THAT MAY RESULT FROM THE USE OF THE MATERIALS OR INFORMATION, WHETHER OR NOT THE RECIPIENT OF MATERIALS HAS BEEN ADVISED OF THE POSSIBILITY OF SUCH DAMAGE.

Skyworks products are not intended for use in medical, lifesaving or life-sustaining applications, or other equipment in which the failure of the Skyworks products could lead to personal injury, death, physical or environmental damage. Skyworks customers using or selling Skyworks products for use in such applications do so at their own risk and agree to fully indemnify Skyworks for any damages resulting from such improper use or sale.

Customers are responsible for their products and applications using Skyworks products, which may deviate from published specifications as a result of design defects, errors, or operation of products outside of published parameters or design specifications. Customers should include design and operating safeguards to minimize these and other risks. Skyworks assumes no liability for applications assistance, customer product design, or damage to any equipment resulting from the use of Skyworks products outside of stated published specifications or parameters.

Skyworks, the Skyworks symbol, and “Breakthrough Simplicity” are trademarks or registered trademarks of Skyworks Solutions, Inc., in the United States and other countries. Third-party brands and names are for identification purposes only, and are the property of their respective owners. Additional information, including relevant terms and conditions, posted at www.skyworksinc.com, are incorporated by reference.