

# IPC-5122

## Desktop/Wallmount Chassis for MicroATX Motherboard with PS/2 Power Supply

**NEW**



### Features

- Streamlined in-chassis airflow design supporting up to LGA775 Intel® Core™ 2 Quad processor with suggested CPU cooler
- Supports up to four expansion slots
- Shock-proof and anti-vibration drive bay design for industrial applications
- Accepts 300 W or 400 W power supply
- Smart monitor system and LED indication for system faults detection
- Easy-to-maintain system fan and reusable air filter



FCC CE

### Specifications

Drive Bay	Slim Optical Drive	Front-accessible	Internal
	3.5"	1	1
Cooling	Fan	1 (12 cm / 85 CFM)	
	Air Filter	Yes	
Front I/O Interface	USB	2	
Miscellaneous	LED Indicators	Power, HDD, fan and temperature	
	Control	Power switch, alarm reset and system reset buttons	
	Rear Panel	Six 9-pin D-Sub openings	
Environment	Temperature	Operating	Non-Operating
	Humidity	0 ~ 40° C (32 ~ 104° F)	-20 ~ 60° C (-4 ~ 140° F)
	Vibration (5 ~ 500 Hz)	10 ~ 85% @ 40° C, non-condensing	10 ~ 95% @ 40° C, non-condensing
	Shock	1 Grms	2 G
	Weight	10 G (with 11 ms duration, half sine wave)	30 G
Physical Characteristics	Dimensions (W x H x D)	157 x 360 x 340 mm (6.2" x 14.2" x 13.4")	
	Weight	6.5 kg (14.3 lb)	

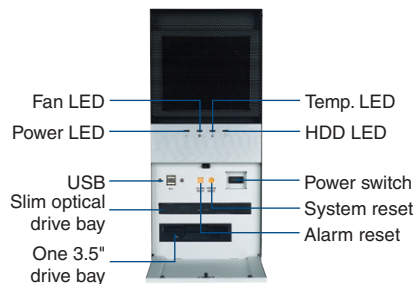

Inside view



Rear view



Easy-open door



Gently press the hook to pull the air filter out



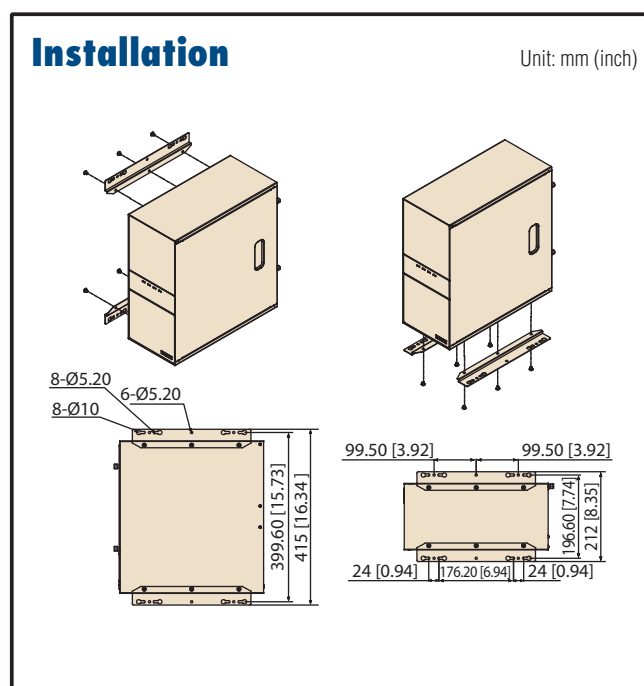
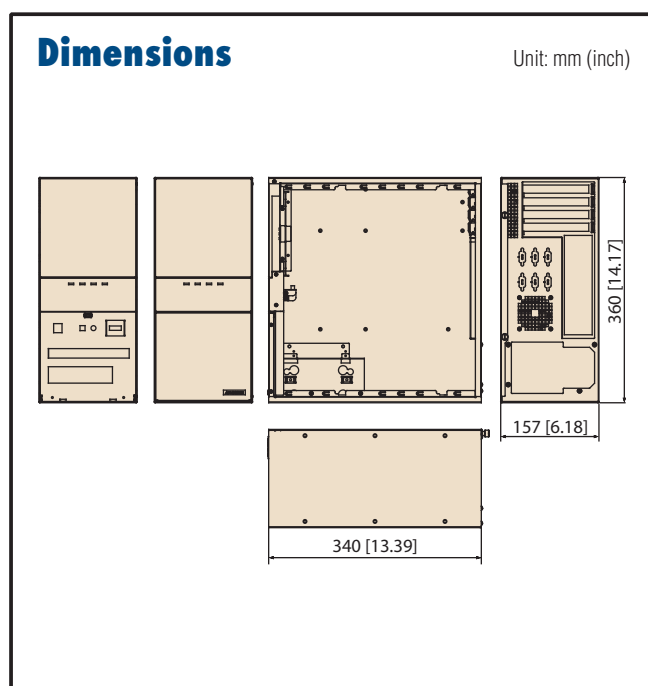

## Power Supply Options

Part Number	Watts	Input	Specifications			
			Output	Mini-load	Safety	MTBF
1757001858	300W	AC 100 ~ 240 V (full range)	+5 V @ 30 A, +3.3 V @ 28 A, +12 V @ 15 A, -5 V @ 0.3 A, -12 V @ 0.8 A, +5 Vsb @ 2 A	+5 V @ 0.5 A, +12 V @ 1 A,	UL/ TUV/CB	100,000 hrs @ 25°C
1757002201	400W	AC 100 ~ 240 V (full range)	+5 V @ 35 A, +3.3 V @ 25 A, +12 V @ 30 A, -5 V @ 0.8 A, -12 V @ 1 A, +5 Vsb @ 2 A	+5 V @ 3 A, +12 V @ 1 A,	UL/ TUV/CB	91,000 hrs @ 25°C

## Accessories

Part Number	Description
1750001661	2U LGA775 CPU cooler (supports up to 84W)
1960022033T000	2U LGA775 CPU cooler (supports up to 95W )
1750003740	85.2 CFM, 120 x 120 x 25 mm system cooling fan
1750003720	27.7 CFM, 60 x 60 x 13 mm system cooling fan
1990001392	Fan filter 140 x 120 x 12 mm
96SCOM-8X-ST-SN-B	Black slim 8X/24X/24X SATA Combo
96SDVR-8X-ST-SN-B	Black slim 8X SATA DVDRW-ROM
96FDD-144-TE-B1	Black 3.5" FDD
96CB-SATAPOWER-6P	SATA Power cable for slim ODD

Note: IPC-5122 with AIMB-564 or AIMB-542 are economic solutions. If the application is in the harsh or severe environment, AIMB-566 is recommended.

## Ordering Information

Part Number	Power Supply	Motherboard	Regulation
IPC-5122-00XE	Without power supply, with ATX switch	-	-
IPC-5122-30ZE	1757001858	-	CE, FCC