

Device Overview

The IDT 89HP0604SB (P0604SB) is a 6Gbps SAS/SATA® Repeater device featuring IDT EyeMax™ technology that compensates for cable and board trace attenuations and ISI jitter, thereby extending connection reach. The device is optimized for SAS/SATA Gen1 and Gen2 high speed serial data streams and contains four data channels, each able to process 6Gbps transmission rates. Each channel consists of an input equalizer and amplifier, signal detection with glitch filter, as well as programmable output swing and de-emphasis. Allowing for application specific optimization, the P0604SB, with its configurable receiver and transmitter features, is ideal for SAS/SATA applications using a wide combination of cables and board trace materials.

All modes of active data transfer are designed with minimized power consumption. In full shutdown mode, the part consumes less than 40mW in worst case environmental conditions.

Applications

- ◆ Blade servers, rack servers
- ◆ SAS/SATA instrumentation
- ◆ Storage systems
- ◆ Cabled SAS/SATA devices

Features

- ◆ Compensates for cable and PCB trace attenuation and ISI jitter
- ◆ Programmable receiver equalization up to 24db
- ◆ Programmable transmitter swing and de-emphasis
- ◆ Recovers data stream even when the differential signal eye is completely closed due to trace attenuation and ISI jitter
- ◆ Full SAS/SATA protocol support
- ◆ Configurable via external pins
- ◆ Leading edge power minimization in active and shutdown modes
- ◆ No external bias resistors or reference clocks required
- ◆ Channel mux mode, demux mode, 1 to 2 channels multicast, and Z-switch function mode
- ◆ Available in a 36-pin QFN package (4.0 x 7.5mm with 0.5mm pitch)

Benefits

- ◆ Extends maximum cable length to over 8 meters and trace length over 48 inches in SAS/SATA applications
- ◆ Minimizes BER

Typical Application

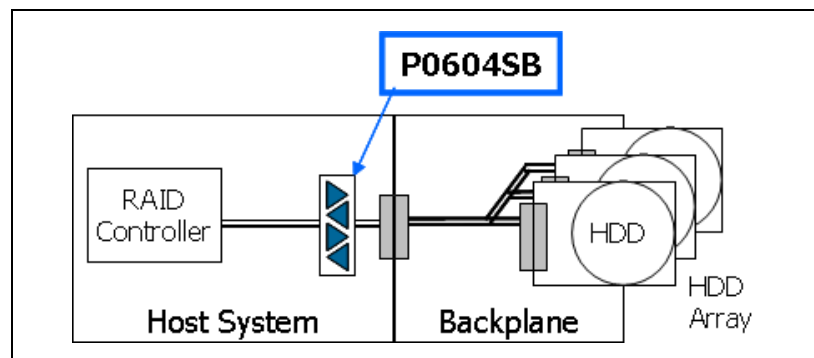

Figure 1 IDT Repeaters in Storage Backplanes

SAS/SATA Compliance

The device was designed to provide end users with features needed to comply with SAS/SATA system application requirements:

- SAS/SATA Out-of-Band (OOB) Support
- Jitter, eye opening, and all other AC and DC specifications.

Block Diagram

The P0604SB contains four high speed channels as shown in Figure 2. Each channel can be routed to different outputs. Depending on user configuration via mode selections, input traffic can be muxed or demuxed. Powerdown (PDB) is provided for state and channel control.

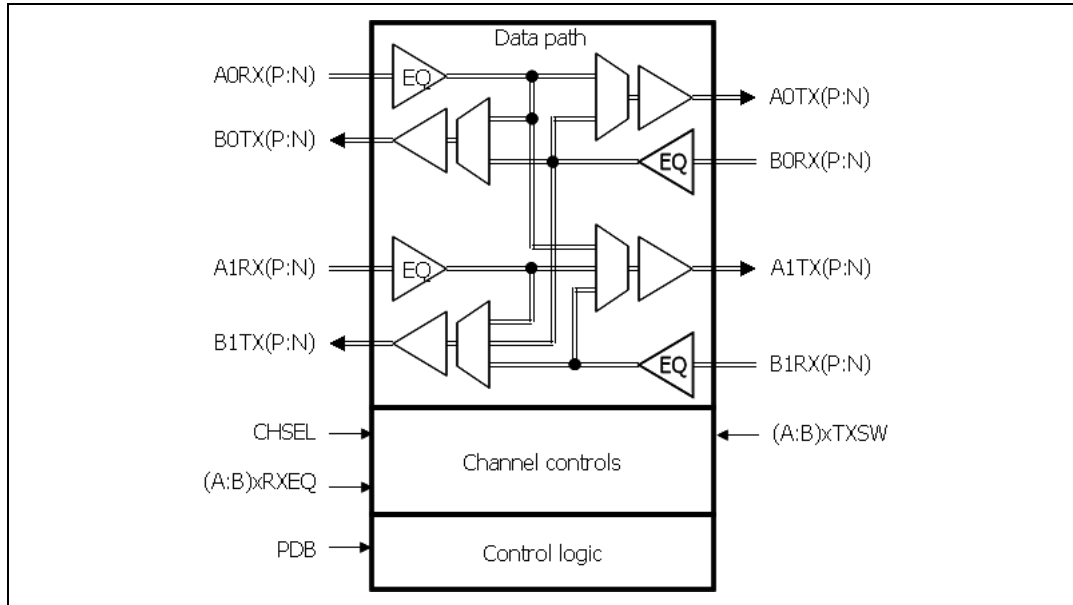

Figure 2 Block Diagram

NOT AN OFFER FOR SALE

The information presented herein is subject to a Non-Disclosure Agreement and is for planning purposes only. Nothing contained in this presentation, whether verbal or written, is intended as, or shall have the effect of, a sale or an offer for sale that creates a contractual power of acceptance.



CORPORATE HEADQUARTERS
 6024 Silver Creek Valley Road
 San Jose, CA 95138

for SALES:
 800-345-7015 or 408-284-8200
 fax: 408-284-2775
 www.idt.com

for Tech Support:
 email: ssdhelp@idt.com
 phone: 408-284-8208