



10-Lane 4-Port Gen2 PCI Express® Switch

89HPES10T4BG2
Data Sheet
Advance Information*

Device Overview

The 89HPES10T4BG2 is a member of IDT's PRECISE™ family of PCI Express® switching solutions. The PES10T4BG2 is a 10-lane, 4-port Gen2 peripheral chip that performs PCI Express Base switching with a feature set optimized for high performance applications such as servers, storage, and communications/networking. It provides connectivity and switching functions between a PCI Express upstream port and two downstream ports and supports switching between downstream ports.

Features

- ◆ **High Performance PCI Express Switch**
 - Ten 5 Gbps Gen2 PCI Express lanes
 - Four switch ports
 - One x4 upstream port
 - Three x2 downstream ports
 - Low latency cut-through switch architecture
 - Support for Max Payload Size up to 2048 bytes
 - One virtual channel
 - Eight traffic classes
 - PCI Express Base Specification Revision 2.0 compliant

- ◆ **Flexible Architecture with Numerous Configuration Options**
 - Automatic per port link width negotiation to x4, x2 or x1
 - Automatic lane reversal on all ports
 - Automatic polarity inversion
 - Ability to load device configuration from serial EEPROM
- ◆ **On-Die Temperature Sensor**
 - Range of 0 to 127.5 degrees Celsius
 - Three programmable temperature thresholds with over and under temperature threshold alarms
 - Automatic recording of maximum high or minimum low temperature
- ◆ **Legacy Support**
 - PCI compatible INTx emulation
 - Bus locking
- ◆ **Highly Integrated Solution**
 - Incorporates on-chip internal memory for packet buffering and queueing
 - Integrates ten 5 Gbps embedded SerDes with 8b/10b encoder/decoder (no separate transceivers needed)
 - Receive equalization (RxEQ)

Advance Information

Block Diagram

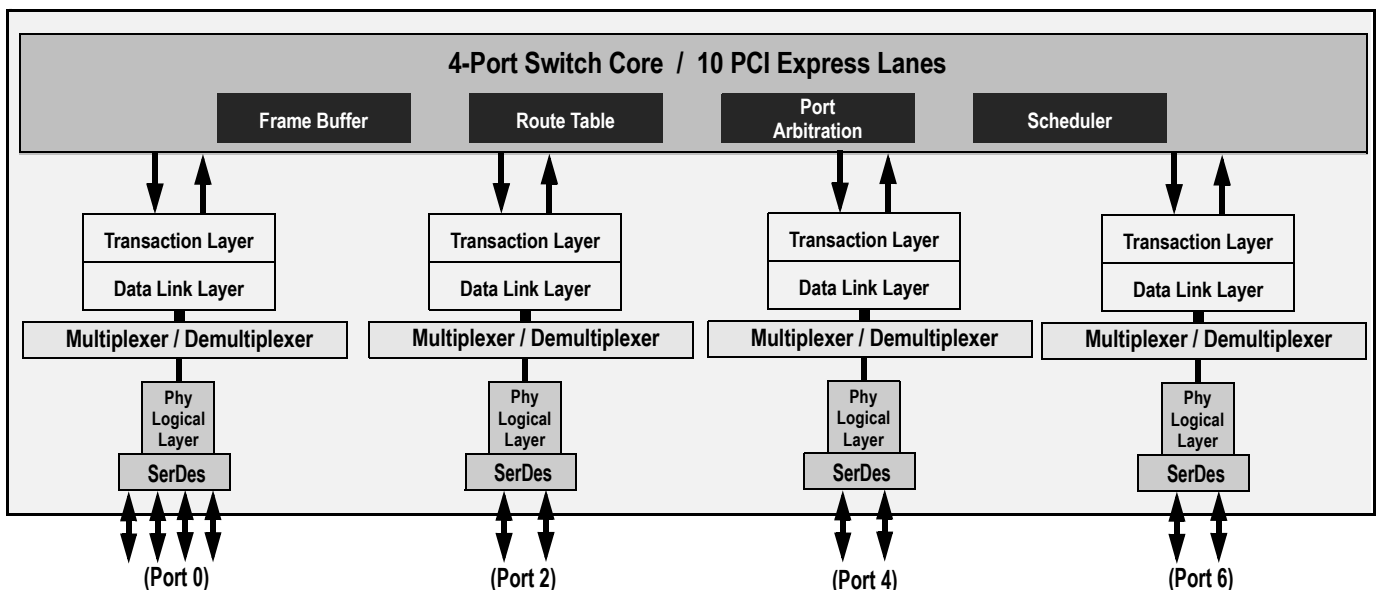

Figure 1 Internal Block Diagram

IDT and the IDT logo are registered trademarks of Integrated Device Technology, Inc.

◆ **Reliability, Availability, and Serviceability (RAS) Features**

- Internal end-to-end parity protection on all TLPs ensures data integrity even in systems that do not implement end-to-end CRC (ECRC)
- Supports ECRC and Advanced Error Reporting
- Supports PCI Express Native Hot-Plug, Hot-Swap capable I/O
- Compatible with Hot-Plug I/O expanders used on PC motherboards
- Supports Hot-Swap

◆ **Power Management**

- Utilizes advanced low-power design techniques to achieve low typical power consumption
- Support PCI Express Power Management Interface specification (PCI-PM 2.0)
- Unused SerDes are disabled.
- Supports Advanced Configuration and Power Interface Specification, Revision 2.0 (ACPI) supporting active link state

◆ **Testability and Debug Features**

- Supports IEEE 1149.1 JTAG and IEEE 1149.6 AC JTAG
- Built in Pseudo-Random Bit Stream (PRBS) generator
- Numerous SerDes test modes
- Ability to read and write any internal register via the SMBus
- Ability to bypass link training and force any link into any mode
- Provides statistics and performance counters

◆ **Nine General Purpose Input/Output Pins**

- Each pin may be individually configured as an input or output
- Each pin may be individually configured as an interrupt input
- Some pins have selectable alternate functions

◆ **Packaged in a 19mm x 19mm 324-ball BGA with 1mm ball spacing**

Product Description

Utilizing standard PCI Express interconnect, the PES10T4BG2 provides the most efficient fan-out solution for applications requiring high throughput, low latency, and simple board layout with a minimum number of board layers. It provides 12 GBps (96 Gbps) of aggregated, full-duplex switching capacity through 10 integrated serial lanes, using proven and robust IDT technology. Each lane provides 5 Gbps of bandwidth in both directions and is fully compliant with PCI Express Base Specification, Revision 2.0.

The PES10T4BG2 is based on a flexible and efficient layered architecture. The PCI Express layer consists of SerDes, Physical, Data Link and Transaction layers in compliance with PCI Express Base specification Revision 2.0. The PES10T4BG2 can operate either as a store and forward or cut-through switch and is designed to switch memory and I/O transactions. It supports eight Traffic Classes (TCs) and one Virtual Channel (VC) with sophisticated resource management to enable efficient switching and I/O connectivity for servers, storage, and embedded processors with limited connectivity.

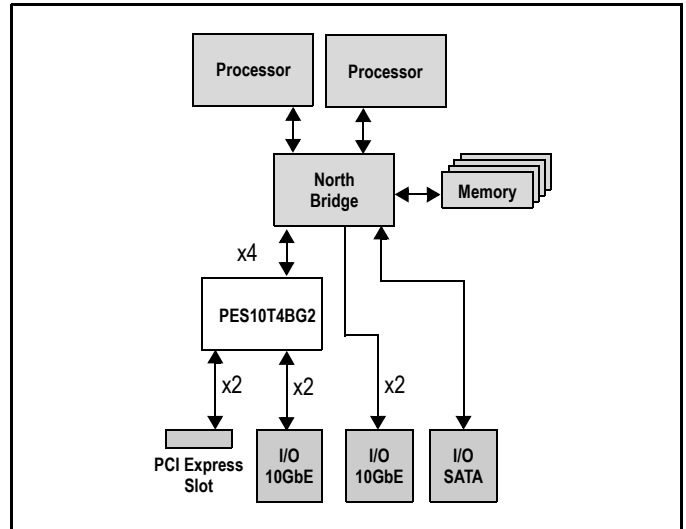

Figure 2 I/O Expansion Application

SMBus Interface

The PES10T4BG2 contains two SMBus interfaces. The slave interface provides full access to the configuration registers in the PES10T4BG2, allowing every configuration register in the device to be read or written by an external agent. The master interface allows the default configuration register values of the PES10T4BG2 to be overridden following a reset with values programmed in an external serial EEPROM. The master interface is also used by an external Hot-Plug I/O expander.

Six pins make up each of the two SMBus interfaces. These pins consist of an SMBus clock pin, an SMBus data pin, and 4 SMBus address pins. In the slave interface, these address pins allow the SMBus address to which the device responds to be configured. In the master interface, these address pins allow the SMBus address of the serial configuration EEPROM from which data is loaded to be configured. The SMBus address is set up on negation of PERSTN by sampling the corresponding address pins. When the pins are sampled, the resulting address is assigned as shown in Table 1.

Bit	Slave SMBus Address	Master SMBus Address
1	SSMBADDR[1]	MSMBADDR[1]
2	SSMBADDR[2]	MSMBADDR[2]
3	SSMBADDR[3]	MSMBADDR[3]
4	0	MSMBADDR[4]
5	SSMBADDR[5]	1
6	1	0
7	1	1

Table 1 Master and Slave SMBus Address Assignment

Advance Information

As shown in Figure 3, the master and slave SMBuses may be used in a unified or split configuration. In the unified configuration, shown in Figure 3(a), the master and slave SMBuses are tied together and the PES10T4BG2 acts both as a SMBus master as well as a SMBus slave on this bus. This requires that the SMBus master or processor that has access to PES10T4BG2 registers supports SMBus arbitration. In some systems, this SMBus master interface may be implemented using general purpose I/O pins on a processor or micro controller, and may not support SMBus arbitration. To support these systems, the PES10T4BG2 may be configured to operate in a split configuration as shown in Figure 3(b).

In the split configuration, the master and slave SMBuses operate as two independent buses and thus multi-master arbitration is never required. The PES10T4BG2 supports reading and writing of the serial EEPROM on the master SMBus via the slave SMBus, allowing in system programming of the serial EEPROM.

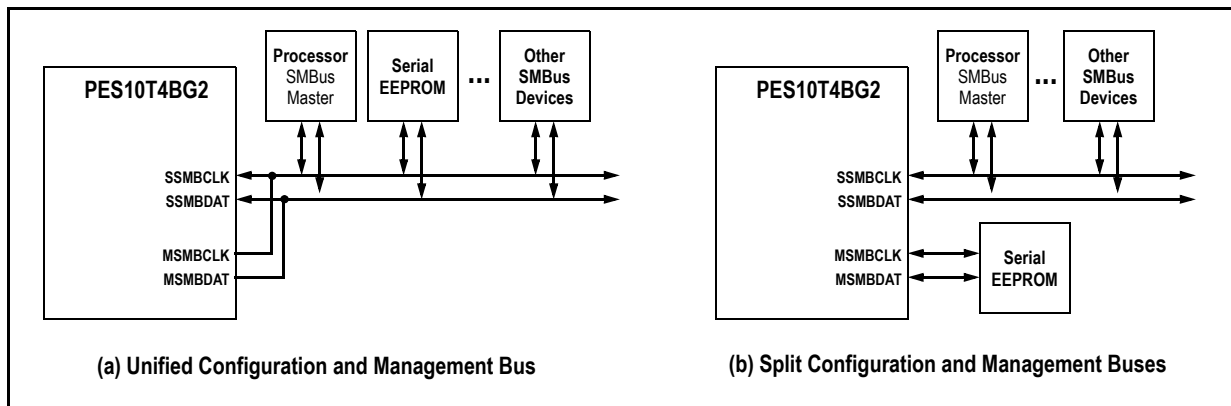

Figure 3 SMBus Interface Configuration Examples

Hot-Plug Interface

The PES10T4BG2 supports PCI Express Hot-Plug on each downstream port. To reduce the number of pins required on the device, the PES10T4BG2 utilizes an external I/O expander, such as that used on PC motherboards, connected to the SMBus master interface. Following reset and configuration, whenever the state of a Hot-Plug output needs to be modified, the PES10T4BG2 generates an SMBus transaction to the I/O expander with the new value of all of the outputs. Whenever a Hot-Plug input changes, the I/O expander generates an interrupt which is received on the IOEXPINTN input pin (alternate function of GPIO) of the PES10T4BG2. In response to an I/O expander interrupt, the PES10T4BG2 generates an SMBus transaction to read the state of all of the Hot-Plug inputs from the I/O expander.

General Purpose Input/Output

The PES10T4BG2 provides 9 General Purpose Input/Output (GPIO) pins that may be used by the system designer as bit I/O ports. Each GPIO pin may be configured independently as an input or output through software control. Some GPIO pins are shared with other on-chip functions. These alternate functions may be enabled via software, SMBus slave interface, or serial configuration EEPROM.

Pin Description

The following tables list the functions of the pins provided on the PES10T4BG2. Some of the functions listed may be multiplexed onto the same pin. The active polarity of a signal is defined using a suffix. Signals ending with an "N" are defined as being active, or asserted, when at a logic zero (low) level. All other signals (including clocks, buses, and select lines) will be interpreted as being active, or asserted, when at a logic one (high) level.

Note: In the PES10T4BG2, the three downstream ports are labeled ports 2, 4, and 6.

Advance Information

Signal	Type	Name/Description
PE0RN[3:0] PE0RP[3:0]	I	PCI Express Port 0 Serial Data Receive. Differential PCI Express receive pairs for port 0. Port 0 is the upstream port.
PE0TN[3:0] PE0TP[3:0]	O	PCI Express Port 0 Serial Data Transmit. Differential PCI Express transmit pairs for port 0. Port 0 is the upstream port.
PE2RN[1:0] PE2RP[1:0]	I	PCI Express Port 2 Serial Data Receive. Differential PCI Express receive pairs for port 2.
PE2TN[1:0] PE2TP[1:0]	O	PCI Express Port 2 Serial Data Transmit. Differential PCI Express transmit pairs for port 2.
PE4RN[1:0] PE4RP[1:0]	I	PCI Express Port 4 Serial Data Receive. Differential PCI Express receive pairs for port 4.
PE4TN[1:0] PE4TP[1:0]	O	PCI Express Port 4 Serial Data Transmit. Differential PCI Express transmit pairs for port 4.
PE6RN[1:0] PE6RP[1:0]	I	PCI Express Port 6 Serial Data Receive. Differential PCI Express receive pairs for port 6.
PE6TN[1:0] PE6TP[1:0]	O	PCI Express Port 6 Serial Data Transmit. Differential PCI Express transmit pairs for port 6.
PEREFCLKP[0] PEREFCLKN[0]	I	PCI Express Reference Clock. Differential reference clock pair input. This clock is used as the reference clock by on-chip PLLs to generate the clocks required for the system logic and on-chip SerDes. The frequency of the differential reference clock is determined by the REFCLKM signal.
REFCLKM	I	PCI Express Reference Clock Mode Select. This signal selects the frequency of the reference clock input. 0x0 - 100 MHz 0x1 - 125 MHz This pin should be static and not change following the negation of PERSTN.

Table 2 PCI Express Interface Pins

Signal	Type	Name/Description
MSMBADDR[4:1]	I	Master SMBus Address. These pins determine the SMBus address of the serial EEPROM from which configuration information is loaded.
MSMBCLK	I/O	Master SMBus Clock. This bidirectional signal is used to synchronize transfers on the master SMBus.
MSMBDAT	I/O	Master SMBus Data. This bidirectional signal is used for data on the master SMBus.
SSMBADDR[5,3:1]	I	Slave SMBus Address. These pins determine the SMBus address to which the slave SMBus interface responds.
SSMBCLK	I/O	Slave SMBus Clock. This bidirectional signal is used to synchronize transfers on the slave SMBus.
SSMBDAT	I/O	Slave SMBus Data. This bidirectional signal is used for data on the slave SMBus.

Table 3 SMBus Interface Pins

Signal	Type	Name/Description
GPIO[0]	I/O	General Purpose I/O. This pin can be configured as a general purpose I/O pin. Alternate function pin name: P2RSTN Alternate function pin type: Output Alternate function: Reset output for downstream port 2.
GPIO[1]	I/O	General Purpose I/O. This pin can be configured as a general purpose I/O pin. Alternate function pin name: P4RSTN Alternate function pin type: Output Alternate function: Reset output for downstream port 4.
GPIO[2]	I/O	General Purpose I/O. This pin can be configured as a general purpose I/O pin. Alternate function pin name: IOEXPINTN0 Alternate function pin type: Input Alternate function: I/O expander interrupt 0 input.
GPIO[3]	I/O	General Purpose I/O. This pin can be configured as a general purpose I/O pin.
GPIO[4]	I/O	General Purpose I/O. This pin can be configured as a general purpose I/O pin. Alternate function pin name: IOEXPINTN2 Alternate function pin type: Input Alternate function: I/O Expander interrupt 2 input.
GPIO[5]	I/O	General Purpose I/O. This pin can be configured as a general purpose I/O pin.
GPIO[6]	I/O	General Purpose I/O. This pin can be configured as a general purpose I/O pin.
GPIO[7]	I/O	General Purpose I/O. This pin can be configured as a general purpose I/O pin. Alternate function pin name: GPEN Alternate function pin type: Output Alternate function: General Purpose Event (GPE) output.
GPIO[11]	I/O	General Purpose I/O. This pin can be configured as a general purpose I/O pin. Alternate function pin name: P6RSTN Alternate function pin type: Output Alternate function: Reset output for downstream port 6.

Table 4 General Purpose I/O Pins

Signal	Type	Name/Description
CCLKDS	I	Common Clock Downstream. The assertion of this pin indicates that all downstream ports are using the same clock source as that provided to downstream devices. This bit is used as the initial value of the Slot Clock Configuration bit in all of the Link Status Registers for downstream ports. The value may be overridden by modifying the SCLK bit in each downstream port's PCIELSTS register.
CCLKUS	I	Common Clock Upstream. The assertion of this pin indicates that the upstream port is using the same clock source as the upstream device. This bit is used as the initial value of the Slot Clock Configuration bit in the Link Status Register for the upstream port. The value may be overridden by modifying the SCLK bit in the P0_PCIELSTS register.
MSMBSMODE	I	Master SMBus Slow Mode. The assertion of this pin indicates that the master SMBus should operate at 100 KHz instead of 400 KHz. This value may not be overridden.
PERSTN	I	Fundamental Reset. Assertion of this signal resets all logic inside PES10T4BG2 and initiates a PCI Express fundamental reset.
RSTHALT	I	Reset Halt. When this signal is asserted during a PCI Express fundamental reset, PES10T4BG2 executes the reset procedure and remains in a reset state with the Master and Slave SMBuses active. This allows software to read and write registers internal to the device before normal device operation begins. The device exits the reset state when the RSTHALT bit is cleared in the SWCTL register by an SMBus master.
SWMODE[2:0]	I	Switch Mode. These configuration pins determine the PES10T4BG2 switch operating mode. 0x0 - Normal switch mode 0x1 - Normal switch mode with Serial EEPROM initialization 0x2 - through 0x7 Reserved These pins should be static and not change following the negation of PERSTN.

Table 5 System Pins

Signal	Type	Name/Description
JTAG_TCK	I	JTAG Clock. This is an input test clock used to clock the shifting of data into or out of the boundary scan logic or JTAG Controller. JTAG_TCK is independent of the system clock with a nominal 50% duty cycle.
JTAG_TDI	I	JTAG Data Input. This is the serial data input to the boundary scan logic or JTAG Controller.

Table 6 Test Pins (Part 1 of 2)

Signal	Type	Name/Description
JTAG_TDO	O	JTAG Data Output. This is the serial data shifted out from the boundary scan logic or JTAG Controller. When no data is being shifted out, this signal is tri-stated.
JTAG_TMS	I	JTAG Mode. The value on this signal controls the test mode select of the boundary scan logic or JTAG Controller.
JTAG_TRST_N	I	JTAG Reset. This active low signal asynchronously resets the boundary scan logic and JTAG TAP Controller. An external pull-up on the board is recommended to meet the JTAG specification in cases where the tester can access this signal. However, for systems running in functional mode, one of the following should occur: <ul style="list-style-type: none"> 1) actively drive this signal low with control logic 2) statically drive this signal low with an external pull-down on the board

Table 6 Test Pins (Part 2 of 2)

Signal	Type	Name/Description
REFRES0	I/O	Port 0 External Reference Resistor. Provides a reference for the Port 0 SerDes bias currents and PLL calibration circuitry. A 3 kOhm +/- 1% resistor should be connected from this pin to ground.
REFRES2	I/O	Port 2 External Reference Resistor. Provides a reference for the Port 2 SerDes bias currents and PLL calibration circuitry. A 3 kOhm +/- 1% resistor should be connected from this pin to ground.
REFRES4	I/O	Port 4 External Reference Resistor. Provides a reference for the Port 4 SerDes bias currents and PLL calibration circuitry. A 3 kOhm +/- 1% resistor should be connected from this pin to ground.
REFRES6	I/O	Port 6 External Reference Resistor. Provides a reference for the Port 6 SerDes bias currents and PLL calibration circuitry. A 3 kOhm +/- 1% resistor should be connected from this pin to ground.
V _{DD} CORE	I	Core V_{DD}. Power supply for core logic.
V _{DD} I/O	I	I/O V_{DD}. LVTTTL I/O buffer power supply.
V _{DD} PEA	I	PCI Express Analog Power. Serdes analog power supply (1.0V).
V _{DD} PEHA	I	PCI Express Analog High Power. Serdes analog power supply (2.5V).
V _{DD} PETA	I	PCI Express Transmitter Analog Voltage. Serdes transmitter analog power supply (1.0V).
V _{SS}	I	Ground.

Table 7 Power, Ground, and SerDes Resistor Pins

Pin Characteristics

Note: Some input pads of the PES10T4BG2 do not contain internal pull-ups or pull-downs. Unused inputs should be tied off to appropriate levels. This is especially critical for unused control signal inputs which, if left floating, could adversely affect operation. Also, any input pin left floating can cause a slight increase in power consumption.

Function	Pin Name	Type	Buffer	I/O Type	Internal Resistor ¹	Notes
PCI Express Interface	PE0RN[3:0]	I	PCIe differential ²	Serial Link		
	PE0RP[3:0]	I				
	PE0TN[3:0]	O				
	PE0TP[3:0]	O				
	PE2RN[1:0]	I				
	PE2RP[1:0]	I				
	PE2TN[1:0]	O				
	PE2TP[1:0]	O				
	PE4RN[1:0]	I				
	PE4RP[1:0]	I				
	PE4TN[1:0]	O				
	PE4TP[1:0]	O				
	PE6RN[1:0]	I				
	PE6RP[1:0]	I				
	PE6TN[1:0]	O				
	PE6TP[1:0]	O				
	PEREFCLKN[0]	I				Diff. Clock Input
	PEREFCLKP[0]	I				
	REFCLKM	I	LVTTTL	Input	pull-down	
SMBus	MSMBADDR[4:1]	I	LVTTTL	Input	pull-up	
	MSMBCLK	I/O		STI ³		pull-up on board
	MSMBDAT	I/O		STI		pull-up on board
	SSMBADDR[5,3:1]	I		Input	pull-up	
	SSMBCLK	I/O		STI		pull-up on board
	SSMBDAT	I/O		STI		pull-up on board
General Purpose I/O	GPIO[11,7:0]	I/O	LVTTTL	STI, High Drive	pull-up	
System Pins	CCLKDS	I	LVTTTL	Input	pull-up	
	CCLKUS	I		Input	pull-up	
	MSMBSMODE	I		Input	pull-down	
	PERSTN	I		STI		
	RSTHALT	I		Input	pull-down	
	SWMODE[2:0]	I		Input	pull-down	

Table 8 Pin Characteristics (Part 1 of 2)

Advance Information

Function	Pin Name	Type	Buffer	I/O Type	Internal Resistor ¹	Notes
EJTAG / JTAG	JTAG_TCK	I	LVTTTL	STI	pull-up	
	JTAG_TDI	I		STI	pull-up	
	JTAG_TDO	O				
	JTAG_TMS	I		STI	pull-up	
	JTAG_TRST_N	I		STI	pull-up	
SerDes Reference Resistors	REFRES0	I/O	Analog			
	REFRES2	I/O				
	REFRES4	I/O				
	REFRES6	I/O				

Table 8 Pin Characteristics (Part 2 of 2)

- ¹. Internal resistor values under typical operating conditions are 92K Ω for pull-up and 90K Ω for pull-down.
- ². All receiver pins set the DC common mode voltage to ground. All transmitters must be AC coupled to the media.
- ³. Schmitt Trigger Input (STI).

Logic Diagram — PES10T4BG2

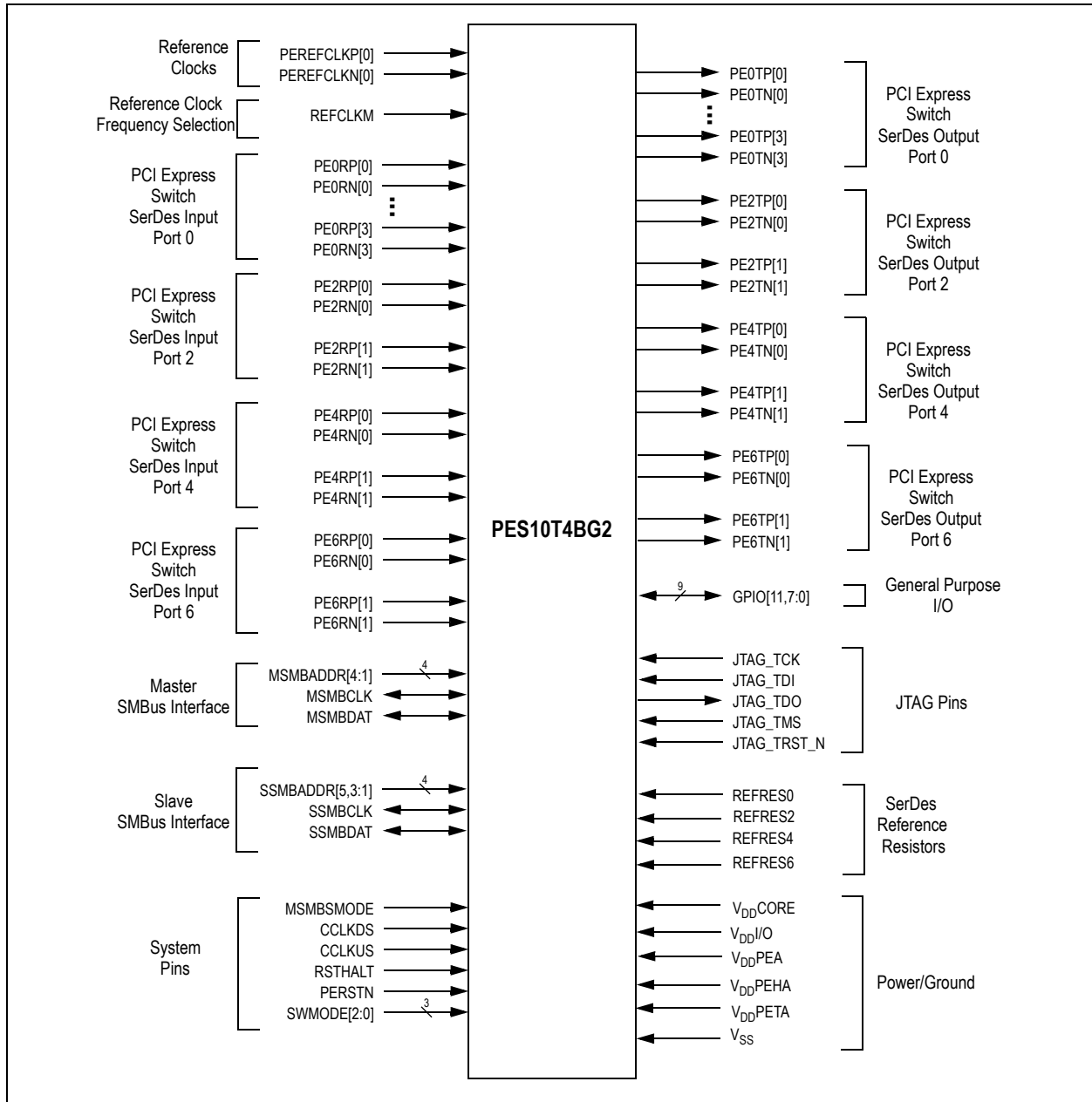

Figure 4 PES10T4BG2 Logic Diagram

Advance Information

System Clock Parameters

Values based on systems running at recommended supply voltages and operating temperatures, as shown in Tables 13 and 14.

Parameter	Description	Condition	Min	Typical	Max	Unit
Refclk _{FREQ}	Input reference clock frequency range		100		125 ¹	MHz
T _{C-RISE}	Rising edge rate	Differential	0.6		4	V/ns
T _{C-FALL}	Falling edge rate	Differential	0.6		4	V/ns
V _{IH}	Differential input high voltage	Differential	+150			mV
V _{IL}	Differential input low voltage	Differential			-150	mV
V _{CROSS}	Absolute single-ended crossing point voltage	Single-ended	+250		+550	mV
V _{CROSS-DELTA}	Variation of V _{CROSS} over all rising clock edges	Single-ended			+140	mV
V _{RB}	Ring back voltage margin	Differential	-100		+100	mV
T _{STABLE}	Time before V _{RB} is allowed	Differential	500			ps
T _{PERIOD-AVG}	Average clock period accuracy		-300		2800	ppm
T _{PERIOD-ABS}	Absolute period, including spread-spec-trum and jitter		9.847		10.203	ns
T _{CC-JITTER}	Cycle to cycle jitter				150	ps
V _{MAX}	Absolute maximum input voltage				+1.15	V
V _{MIN}	Absolute minimum input voltage		-0.3			V
Duty Cycle	Duty cycle		40		60	%
Rise/Fall Matching	Single ended rising Refclk edge rate versus falling Refclk edge rate			20		%
Z _{C-DC}	Clock source output DC impedance		40		60	Ω

Table 9 Input Clock Requirements

¹. The input clock frequency will be either 100 or 125 MHz depending on signal REFCLKM.

AC Timing Characteristics

Parameter	Description	Gen 1			Gen 2			Units
		Min ¹	Typ ¹	Max ¹	Min ¹	Typ ¹	Max ¹	
PCIe Transmit								
UI	Unit Interval	399.88	400	400.12	199.94	200	200.06	ps
T _{TX-EYE}	Minimum Tx Eye Width	0.75			0.75			UI
T _{TX-EYE-MEDIAN-to-MAX-JITTER}	Maximum time between the jitter median and maximum deviation from the median			0.125				UI
T _{TX-RISE} , T _{TX-FALL}	TX Rise/Fall Time: 20% - 80%	0.125			0.15			UI
T _{TX-IDLE-MIN}	Minimum time in idle	20			20			UI

Table 10 PCIe AC Timing Characteristics (Part 1 of 2)

Advance Information

Parameter	Description	Gen 1			Gen 2			Units
		Min ¹	Typ ¹	Max ¹	Min ¹	Typ ¹	Max ¹	
T _{TX-IDLE-SET-TO-IDLE}	Maximum time to transition to a valid Idle after sending an Idle ordered set			8			8	ns
T _{TX-IDLE-TO-DIFF-DATA}	Maximum time to transition from valid idle to diff data			8			8	ns
T _{TX-SKEW}	Transmitter data skew between any 2 lanes			1.3			1.3	ns
T _{MIN-PULSED}	Minimum Instantaneous Lone Pulse Width	NA			0.9			UI
T _{TX-HF-DJ-DD}	Transmitter Deterministic Jitter > 1.5MHz Bandwidth	NA					0.15	UI
T _{RF-MISMATCH}	Rise/Fall Time Differential Mismatch	NA					0.1	UI
PCIe Receive								
UI	Unit Interval	399.88	400	400.12	199.94		200.06	ps
T _{RX-EYE (with jitter)}	Minimum Receiver Eye Width (jitter tolerance)	0.4			0.4			UI
T _{RX-EYE-MEDIUM TO MAX JITTER}	Max time between jitter median & max deviation			0.3				UI
T _{RX-SKEW}	Lane to lane input skew			20			8	ns
T _{RX-HF-RMS}	1.5 — 100 MHz RMS jitter (common clock)	NA					3.4	ps
T _{RX-HF-DJ-DD}	Maximum tolerable DJ by the receiver (common clock)	NA					88	ps
T _{RX-LF-RMS}	10 KHz to 1.5 MHz RMS jitter (common clock)	NA					4.2	ps
T _{RX-MIN-PULSE}	Minimum receiver instantaneous eye width	NA			0.6			UI

Table 10 PCIe AC Timing Characteristics (Part 2 of 2)

¹ Minimum, Typical, and Maximum values meet the requirements under PCI Specification 2.0

Advance Information

Signal	Symbol	Reference Edge	Min	Max	Unit	Timing Diagram Reference
GPIO						
GPIO[11,7:0] ¹	Tpw ²	None	50	—	ns	

Table 11 GPIO AC Timing Characteristics

¹ GPIO signals must meet the setup and hold times if they are synchronous or the minimum pulse width if they are asynchronous.

² The values for this symbol were determined by calculation, not by testing.

Signal	Symbol	Reference Edge	Min	Max	Unit	Timing Diagram Reference
JTAG						
JTAG_TCK	Tper_16a	none	50.0	—	ns	See Figure 5.
	Thigh_16a, Tlow_16a		10.0	25.0	ns	
JTAG_TMS ¹ , JTAG_TDI	Tsu_16b	JTAG_TCK rising	2.4	—	ns	
	Thld_16b		1.0	—	ns	
JTAG_TDO	Tdo_16c	JTAG_TCK falling	—	20	ns	
	Tdz_16c ²		—	20	ns	
JTAG_TRST_N	Tpw_16d ²	none	25.0	—	ns	

Table 12 JTAG AC Timing Characteristics

¹ The JTAG specification, IEEE 1149.1, recommends that JTAG_TMS should be held at 1 while the signal applied at JTAG_TRST_N changes from 0 to 1. Otherwise, a race may occur if JTAG_TRST_N is deasserted (going from low to high) on a rising edge of JTAG_TCK when JTAG_TMS is low, because the TAP controller might go to either the Run-Test/Idle state or stay in the Test-Logic-Reset state.

² The values for this symbol were determined by calculation, not by testing.

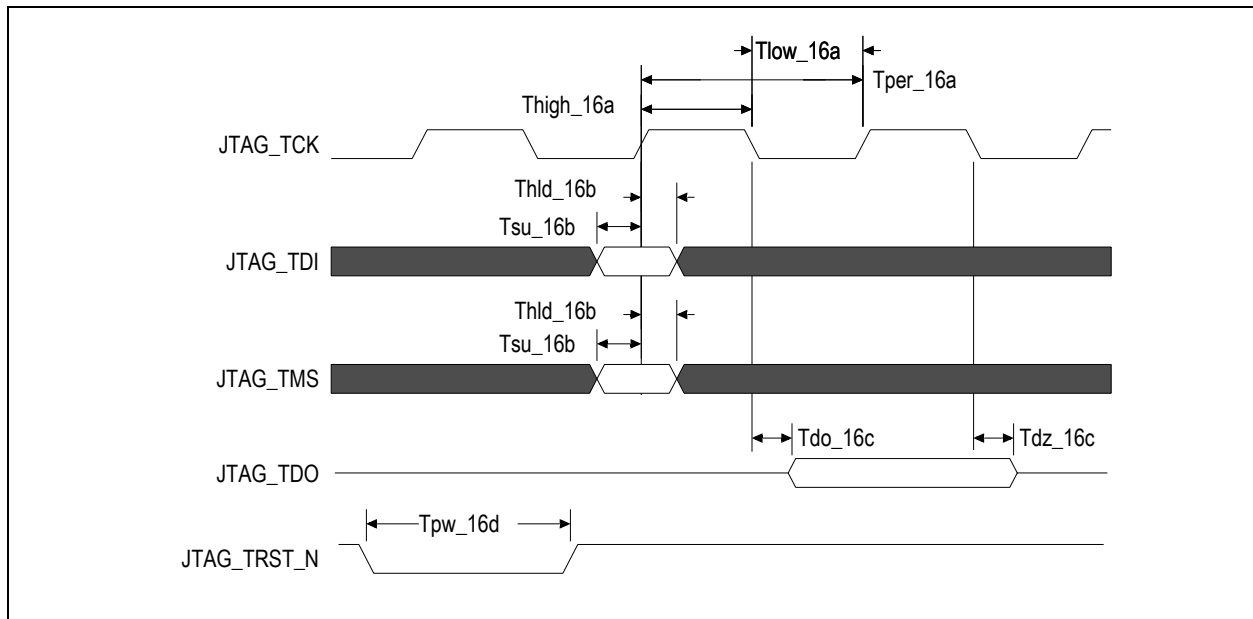

Figure 5 JTAG AC Timing Waveform

Advance Information

Recommended Operating Supply Voltages

Symbol	Parameter	Minimum	Typical	Maximum	Unit
V _{DD} CORE	Internal logic supply	0.9	1.0	1.1	V
V _{DD} I/O	I/O supply except for SerDes LVPECL/CML	3.135	3.3	3.465	V
V _{DD} PEA ¹	PCI Express Analog Power	0.95	1.0	1.1	V
V _{DD} PEHA ²	PCI Express Analog High Power	2.25	2.5	2.75	V
V _{DD} PETA	PCI Express Transmitter Analog Voltage	0.95	1.0	1.1	V
V _{SS}	Common ground	0	0	0	V

Table 13 PES10T4BG2 Operating Voltages

¹. V_{DD}PEA should have no more than 25mV_{peak-peak} AC power supply noise superimposed on the 1.0V nominal DC value.

². V_{DD}PEHA should have no more than 50mV_{peak-peak} AC power supply noise superimposed on the 2.5V nominal DC value.

Power-Up/Power-Down Sequence

During power supply ramp-up, V_{DD}CORE must remain at least 1.0V below V_{DD}I/O at all times. There are no other power-up sequence requirements for the various operating supply voltages.

The power-down sequence can occur in any order.

Recommended Operating Temperature

Grade	Temperature
Commercial	0°C to +70°C Ambient

Table 14 PES10T4BG2 Operating Temperatures

Power Consumption

Typical power is measured under the following conditions: 25°C Ambient, 35% total link usage on all ports, typical voltages defined in Table 13 (and also listed below).

Maximum power is measured under the following conditions: 70°C Ambient, 85% total link usage on all ports, maximum voltages defined in Table 13 (and also listed below).

Number of active Lanes per Port		Core Supply		PCIe Analog Supply		PCIe Analog High Supply		PCIe Termination Supply		I/O Supply		Total	
		Typ 1.0V	Max 1.1V	Typ 1.0V	Max 1.1V	Typ 2.5V	Max 2.75V	Typ 1.0V	Max 1.1V	Typ 3.3V	Max 3.465V	Typ Power	Max Power
4/2/2/2 (Full swing)	mA	531	781	402	484	194	275	207	238	3	4		
	Watts	0.53	0.86	0.40	0.53	0.49	0.76	0.21	0.26	0.01	0.02	1.64	2.43
2/2/2/2 (Full swing)	mA	440	550	320	352	138	165	108	117	3	4		
	Watts	0.44	0.61	0.32	0.39	0.25	0.45	0.11	0.13	.01	.02	1.23	1.6

Table 15 PES10T4BG2 Power Consumption

Thermal Considerations

This section describes thermal considerations for the PES10T4BG2 (19mm² CABGA324 package). The data in Table 16 below contains information that is relevant to the thermal performance of the PES10T4BG2 switch.

Note: It is important for the reliability of this device in any user environment that the junction temperature not exceed the T_{J(max)} value

Symbol	Parameter	Value	Units	Conditions
T _{J(max)}	Junction Temperature	125	°C	Maximum
T _{A(max)}	Ambient Temperature	70	°C	Maximum
θ _{JA(effective)}	Effective Thermal Resistance, Junction-to-Ambient	23.6	°C/W	Zero air flow
		16.8	°C/W	1 m/S air flow
		15.4	°C/W	2 m/S air flow
θ _{JB}	Thermal Resistance, Junction-to-Board	14.5	°C/W	
θ _{JC}	Thermal Resistance, Junction-to-Case	7.6	°C/W	
P	Power Dissipation of the Device	2.43	Watts	Maximum

Table 16 Thermal Specifications for PES10T4BG2, 19x19 mm CABGA324 Package

specified in Table 16. Consequently, the effective junction to ambient thermal resistance (θ_{JA}) for the worst case scenario must be maintained below the value determined by the formula:

$$\theta_{JA} = (T_{J(max)} - T_{A(max)})/P$$

Given that the values of T_{J(max)}, T_{A(max)}, and P are known, the value of desired θ_{JA} becomes a known entity to the system designer. How to achieve the desired θ_{JA} is left up to the board or system designer, but in general, it can be achieved by adding the effects of θ_{JC} (value provided in Table 16), thermal resistance of the chosen adhesive (θ_{CS}), that of the heat sink (θ_{SA}), amount of airflow, and properties of the circuit board (number of layers and size of the board). As a general guideline, this device will not need a heat sink if the board has 8 or more layers AND the board size is larger than 4"x12" AND airflow in excess of 0.5 m/s is available. It is strongly recommended that users perform their own thermal analysis for their own board and system design scenarios.

DC Electrical Characteristics

Values based on systems running at recommended supply voltages, as shown in Table 13.

Note: See Table 8, Pin Characteristics, for a complete I/O listing.

I/O Type	Parameter	Description	Gen1			Gen2			Unit	Condi-tions	
			Min ¹	Typ ¹	Max ¹	Min ¹	Typ ¹	Max ¹			
Serial Link	PCIe Transmit										
	V _{TX-DIFFp-p}	Differential peak-to-peak output voltage	800		1200	800		1200	mV		
	V _{TX-DIFFp-p-LOW}	Low-Drive Differential Peak to Peak Output Voltage	400		1200	400		1200	mV		
	V _{TX-DE-RATIO-3.5dB}	De-emphasized differential output voltage	-3		-4	-3.0	-3.5	-4.0	dB		
	V _{TX-DE-RATIO-6.0dB}	De-emphasized differential output voltage	NA			-5.5	-6.0	-6.5	dB		
	V _{TX-DC-CM}	DC Common mode voltage	0		3.6	0		3.6	V		
	V _{TX-CM-ACP}	RMS AC peak common mode output voltage			20				mV		
	V _{TX-CM-DC-active-idle-delta}	Abs delta of DC common mode voltage between L0 and idle			100			100	mV		
	V _{TX-CM-DC-line-delta}	Abs delta of DC common mode voltage between D+ and D-			25			25	mV		
	V _{TX-Idle-DiffP}	Electrical idle diff peak output			20			20	mV		
	RL _{TX-DIFF}	Transmitter Differential Return loss	10						10	dB	0.05 - 1.25GHz
									8	dB	1.25 - 2.5GHz
	RL _{TX-CM}	Transmitter Common Mode Return loss	6					6	dB		
	Z _{TX-DIFF-DC}	DC Differential TX impedance	80	100	120			120	Ω		
	V _{TX-CM-ACpp}	Peak-Peak AC Common	NA					100	mV		
	V _{TX-DC-CM}	Transmit Driver DC Common Mode Voltage	0		3.6	0		3.6	V		
V _{TX-RCV-DETECT}	The amount of voltage change allowed during Receiver Detection			600			600	mV			
I _{TX-SHORT}	Transmitter Short Circuit Current Limit	0		90				90	mA		

Advance Information

Table 17 DC Electrical Characteristics (Part 1 of 2)

I/O Type	Parameter	Description	Gen1			Gen2			Unit	Condi- tions
			Min ¹	Typ ¹	Max ¹	Min ¹	Typ ¹	Max ¹		
Serial Link (cont.)	PCIe Receive									
	V _{RX-DIFFp-p}	Differential input voltage (peak-to-peak)	175		1200	120		1200	mV	
	RL _{RX-DIFF}	Receiver Differential Return Loss	10					10	dB	0.05 - 1.25GHz
								8		1.25 - 2.5GHz
	RL _{RX-CM}	Receiver Common Mode Return Loss	6					6	dB	
	Z _{RX-DIFF-DC}	Differential input impedance (DC)	80	100	120	Refer to return loss spec			Ω	
	Z _{RX-DC}	DC common mode impedance	40	50	60	40		60	Ω	
	Z _{RX-COMM-DC}	Powered down input common mode impedance (DC)	200k	350k				50k	Ω	
	Z _{RX-HIGH-IMP-DC-POS}	DC input CM input impedance for V>0 during reset or power down			50k			50k	Ω	
	Z _{RX-HIGH-IMP-DC-NEG}	DC input CM input impedance for V<0 during reset or power down			1.0k			1.0k	Ω	
V _{RX-IDLE-DET-DIFFp-p}	Electrical idle detect threshold	65		175	65		175	mV		
V _{RX-CM-ACp}	Receiver AC common-mode peak voltage			150			150	mV	V _{RX-CM-ACp}	
PCIe REFCLK										
	C _{IN}	Input Capacitance	1.5	—		1.5	—		pF	
Other I/Os										
LOW Drive Output	I _{OL}		—	2.5	—	—	2.5	—	mA	V _{OL} = 0.4v
	I _{OH}		—	-5.5	—	—	-5.5	—	mA	V _{OH} = 1.5V
High Drive Output	I _{OL}		—	12.0	—	—	12.0	—	mA	V _{OL} = 0.4v
	I _{OH}		—	-20.0	—	—	-20.0	—	mA	V _{OH} = 1.5V
Schmitt Trigger Input (STI)	V _{IL}		-0.3	—	0.8	-0.3	—	0.8	V	—
	V _{IH}		2.0	—	V _{DD} /O + 0.5	2.0	—	V _{DD} /O + 0.5	V	—
Input	V _{IL}		-0.3	—	0.8	-0.3	—	0.8	V	—
	V _{IH}		2.0	—	V _{DD} /O + 0.5	2.0	—	V _{DD} /O + 0.5	V	—
Capacitance	C _{IN}		—	—	8.5	—	—	8.5	pF	—
Leakage	Inputs		—	—	± 10	—	—	± 10	μA	V _{DD} /O (max)
	I/O _{LEAK} w/o Pull-ups/downs		—	—	± 10	—	—	± 10	μA	V _{DD} /O (max)
	I/O _{LEAK} WITH Pull-ups/downs		—	—	± 80	—	—	± 80	μA	V _{DD} /O (max)

Table 17 DC Electrical Characteristics (Part 2 of 2)

¹ Minimum, Typical, and Maximum values meet the requirements under PCI Specification 2.0.

Package Pinout — 324-BGA Signal Pinout for PES10T4BG2

The following table lists the pin numbers and signal names for the PES10T4BG2 device.

Pin	Function	Alt	Pin	Function	Alt	Pin	Function	Alt	Pin	Function	Alt
A1	V _{SS}		B17	SWMODE_1		D15	GPIO_01	1	F13	V _{SS}	
A2	V _{SS}		B18	SWMODE_2		D16	PE4TP00		F14	V _{DD} CORE	
A3	PE0RN00		C1	JTAG_TCK		D17	V _{DD} PETA		F15	V _{DD} I/O	
A4	PE0RP00		C2	PE0TP00		D18	GPIO_03		F16	V _{SS}	
A5	V _{SS}		C3	PE0TN00		E1	V _{SS}		F17	V _{DD} PEA	
A6	PE0RN01		C4	V _{SS}		E2	V _{DD} PEA		F18	PE4RP00	
A7	PE0RP01		C5	PE0TP01		E3	NC		G1	V _{SS}	
A8	V _{SS}		C6	PE0TN01		E4	JTAG_TMS		G2	V _{DD} PEA	
A9	PEREFCLKP0		C7	V _{DD} PEA		E5	V _{DD} CORE		G3	V _{DD} PETA	
A10	PEREFCLKN0		C8	V _{DD} PETA		E6	V _{DD} I/O		G4	V _{SS}	
A11	V _{SS}		C9	V _{SS}		E7	V _{DD} PEHA		G5	V _{DD} CORE	
A12	PE0RN02		C10	PE0TP02		E8	V _{DD} PEHA		G6	V _{DD} I/O	
A13	PE0RP02		C11	PE0TN02		E9	V _{DD} PEHA		G7	V _{SS}	
A14	V _{SS}		C12	V _{DD} PETA		E10	V _{DD} CORE		G8	V _{SS}	
A15	PE0RN03		C13	PE0TP03		E11	V _{DD} PEHA		G9	V _{DD} CORE	
A16	PE0RP03		C14	PE0TN03		E12	V _{DD} I/O		G10	V _{SS}	
A17	CCLKDS		C15	V _{SS}		E13	V _{DD} CORE		G11	V _{SS}	
A18	SWMODE_0		C16	CCLKUS		E14	V _{DD} I/O		G12	V _{SS}	
B1	JTAG_TDI		C17	PERSTN		E15	GPIO_00	1	G13	V _{DD} I/O	
B2	V _{SS}		C18	GPIO_02	1	E16	PE4TN00		G14	V _{DD} PEHA	
B3	V _{SS}		D1	V _{SS}		E17	V _{SS}		G15	V _{SS}	
B4	V _{SS}		D2	JTAG_TDO		E18	PE4RN00		G16	PE4TP01	
B5	V _{SS}		D3	V _{DD} PETA		F1	V _{SS}		G17	V _{DD} PETA	
B6	V _{SS}		D4	JTAG_TRST_N		F2	V _{DD} PEHA		G18	V _{SS}	
B7	V _{SS}		D5	V _{DD} I/O		F3	NC		H1	V _{SS}	
B8	V _{SS}		D6	V _{DD} PEHA		F4	V _{DD} CORE		H2	V _{SS}	
B9	V _{DD} PEA		D7	V _{SS}		F5	V _{DD} I/O		H3	NC	
B10	V _{DD} PEA		D8	V _{DD} CORE		F6	V _{SS}		H4	V _{SS}	
B11	V _{DD} PETA		D9	V _{DD} CORE		F7	V _{DD} CORE		H5	V _{DD} PEHA	
B12	V _{SS}		D10	REFRES0		F8	V _{SS}		H6	V _{SS}	
B13	V _{SS}		D11	V _{DD} PEA		F9	V _{SS}		H7	V _{DD} CORE	
B14	V _{DD} CORE		D12	V _{DD} CORE		F10	V _{SS}		H8	V _{SS}	
B15	V _{SS}		D13	V _{SS}		F11	V _{SS}		H9	V _{SS}	
B16	V _{DD} PEA		D14	RSTHALT		F12	V _{DD} CORE		H10	V _{SS}	

Table 18 PES10T4BG2 324-pin Signal Pin-Out (Part 1 of 3)

Advance Information

Pin	Function	Alt	Pin	Function	Alt	Pin	Function	Alt	Pin	Function	Alt
H11	V _{DD} CORE		K13	V _{SS}		M15	V _{SS}		P17	V _{SS}	
H12	V _{SS}		K14	V _{DD} CORE		M16	V _{DD} PETA		P18	V _{SS}	
H13	V _{SS}		K15	V _{SS}		M17	V _{DD} PEA		R1	PE2RP00	
H14	V _{DD} PEHA		K16	NC		M18	V _{SS}		R2	V _{SS}	
H15	V _{DD} CORE		K17	REFRES4		N1	PE2RN01		R3	PE2TP00	
H16	PE4TN01		K18	V _{SS}		N2	V _{DD} PEA		R4	SSMBADDR_2	
H17	V _{SS}		L1	V _{SS}		N3	V _{SS}		R5	V _{DD} /O	
H18	PE4RN01		L2	V _{DD} PEA		N4	V _{SS}		R6	MSMBMODE	
J1	V _{SS}		L3	PE2TN01		N5	V _{DD} CORE		R7	V _{DD} CORE	
J2	V _{DD} PETA		L4	V _{DD} CORE		N6	V _{SS}		R8	V _{SS}	
J3	NC		L5	V _{DD} PEHA		N7	V _{DD} /O		R9	V _{SS}	
J4	REFRES2		L6	V _{SS}		N8	V _{SS}		R10	V _{SS}	
J5	V _{DD} CORE		L7	V _{SS}		N9	V _{SS}		R11	V _{DD} CORE	
J6	V _{SS}		L8	V _{SS}		N10	V _{SS}		R12	V _{SS}	
J7	V _{SS}		L9	V _{SS}		N11	V _{SS}		R13	V _{DD} /O	
J8	V _{SS}		L10	V _{SS}		N12	V _{DD} /O		R14	V _{SS}	
J9	V _{DD} CORE		L11	V _{SS}		N13	V _{SS}		R15	V _{SS}	
J10	V _{SS}		L12	V _{DD} CORE		N14	V _{DD} CORE		R16	GPIO_04	1
J11	V _{SS}		L13	V _{SS}		N15	V _{DD} CORE		R17	V _{DD} PEA	
J12	V _{DD} CORE		L14	V _{DD} PEHA		N16	NC		R18	V _{SS}	
J13	V _{SS}		L15	V _{SS}		N17	V _{DD} PEHA		T1	PE2RN00	
J14	V _{DD} PEHA		L16	NC		N18	V _{SS}		T2	V _{DD} PETA	
J15	V _{SS}		L17	V _{DD} PETA		P1	V _{SS}		T3	V _{SS}	
J16	V _{DD} PEA		L18	V _{SS}		P2	V _{SS}		T4	SSMBADDR_5	
J17	V _{DD} PEA		M1	PE2RP01		P3	PE2TN00		T5	V _{SS}	
J18	PE4RP01		M2	V _{DD} PETA		P4	SSMBADDR_1		T6	MSMBDAT	
K1	V _{SS}		M3	PE2TP01		P5	V _{DD} CORE		T7	MSMBADDR_3	
K2	V _{DD} PEA		M4	V _{SS}		P6	V _{DD} /O		T8	V _{DD} PEA	
K3	V _{SS}		M5	V _{DD} PEHA		P7	V _{DD} CORE		T9	PE6TN01	
K4	V _{SS}		M6	V _{DD} /O		P8	V _{DD} PEHA		T10	PE6TP01	
K5	V _{DD} PEHA		M7	V _{DD} CORE		P9	V _{DD} PEHA		T11	V _{DD} PEA	
K6	V _{SS}		M8	V _{SS}		P10	V _{DD} CORE		T12	PE6TN00	
K7	V _{DD} CORE		M9	V _{DD} CORE		P11	V _{DD} PEHA		T13	PE6TP00	
K8	V _{SS}		M10	V _{SS}		P12	V _{DD} CORE		T14	V _{DD} PETA	
K9	V _{SS}		M11	V _{DD} CORE		P13	V _{DD} CORE		T15	V _{SS}	
K10	V _{DD} CORE		M12	V _{SS}		P14	V _{DD} /O		T16	GPIO_06	
K11	V _{SS}		M13	V _{DD} /O		P15	V _{SS}		T17	GPIO_05	

Advance Information

Table 18 PES10T4BG2 324-pin Signal Pin-Out (Part 2 of 3)

Pin	Function	Alt	Pin	Function	Alt	Pin	Function	Alt	Pin	Function	Alt
K12	V _{SS}		M14	V _{DD} CORE		P16	NC		T18	V _{SS}	
U1	V _{SS}		U10	V _{DD} PETA		V1	V _{SS}		V10	V _{SS}	
U2	V _{SS}		U11	V _{SS}		V2	V _{SS}		V11	PE6RP00	
U3	SSMBCLK		U12	V _{SS}		V3	SSMBDAT		V12	PE6RN00	
U4	SSMBADDR_3		U13	V _{SS}		V4	V _{SS}		V13	V _{SS}	
U5	V _{SS}		U14	V _{SS}		V5	MSMBADDR_4		V14	V _{SS}	
U6	MSMBCLK		U15	REFCLKM		V6	MSMBADDR_2		V15	V _{SS}	
U7	MSMBADDR_1		U16	GPIO_07	1	V7	REFRES6		V16	GPIO_11	1
U8	V _{DD} PEA		U17	V _{SS}		V8	PE6RP01		V17	V _{SS}	
U9	V _{SS}		U18	V _{SS}		V9	PE6RN01		V18	V _{SS}	

Table 18 PES10T4BG2 324-pin Signal Pin-Out (Part 3 of 3)

Alternate Signal Functions

Pin	GPIO	Alternate
E15	GPIO_00	P2RSTN
D15	GPIO_01	P4RSTN
C18	GPIO_02	IOEXPINTN0
R16	GPIO_04	IOEXPINTN2
U16	GPIO_07	GPEN
V16	GPIO_11	P6RSTN

Table 19 PES10T4BG2 Alternate Signal Functions

No Connection Pins

NC Pins
E3
F3
H3
J3
K16
L16
N16
P16

Table 20 PES10T4BG2 No Connection Pins

Advance Information

Power Pins

V_{DD}Core	V_{DD}Core	V_{DD}I/O	V_{DD}PEA	V_{DD}PEHA	V_{DD}PETA
B14	K7	D5	B9	D6	B11
D8	K10	E6	B10	E7	C8
D9	K14	E12	B16	E8	C12
D12	L4	E14	C7	E9	D3
E5	L12	F5	D11	E11	D17
E10	M7	F15	E2	F2	G3
E13	M9	G6	F17	G14	G17
F4	M11	G13	G2	H5	J2
F7	M14	M6	J16	H14	L17
F12	N5	M13	J17	J14	M2
F14	N14	N7	K2	K5	M16
G5	N15	N12	L2	L5	T2
G9	P5	P6	M17	L14	T14
H7	P7	P14	N2	M5	U10
H11	P10	R5	R17	N17	
H15	P12	R13	T8	P8	
J5	P13		T11	P9	
J9	R7		U8	P11	
J12	R11				

Table 21 PES10T4BG2 Power Pins

Ground Pins

V_{ss}	V_{ss}	V_{ss}	V_{ss}	V_{ss}	V_{ss}
A1	E1	H6	K12	N6	T15
A2	E17	H8	K13	N8	T18
A5	F1	H9	K15	N9	U1
A8	F6	H10	K18	N10	U2
A11	F8	H12	L1	N11	U5
A14	F9	H13	L6	N13	U9
B2	F10	H17	L7	N18	U11
B3	F11	J1	L8	P1	U12
B4	F13	J6	L9	P2	U13
B5	F16	J7	L10	P15	U14
B6	G1	J8	L11	P17	U17
B7	G4	J10	L13	P18	U18
B8	G7	J11	L15	R2	V1
B12	G8	J13	L18	R8	V2
B13	G10	J15	M4	R9	V4
B15	G11	K1	M8	R10	V10
C4	G12	K3	M10	R12	V13
C9	G15	K4	M12	R14	V14
C15	G18	K6	M15	R15	V15
D1	H1	K8	M18	R18	V17
D7	H2	K9	N3	T3	V18
D13	H4	K11	N4	T5	

Table 22 PES10T4BG2 Ground Pins

Signals Listed Alphabetically

Signal Name	I/O Type	Location	Signal Category
CCLKDS	I	A17	System
CCLKUS	I	C16	
GPIO_00	I/O	E15	General Purpose Input/Output
GPIO_01	I/O	D15	
GPIO_02	I/O	C18	
GPIO_03	I/O	D18	
GPIO_04	I/O	R16	
GPIO_05	I/O	T17	
GPIO_06	I/O	T16	
GPIO_07	I/O	U16	
GPIO_11	I/O	V16	
JTAG_TCK	I	C1	
JTAG_TDI	I	B1	
JTAG_TDO	O	D2	
JTAG_TMS	I	E4	
JTAG_TRST_N	I	D4	
MSMBADDR_1	I	U7	SMBus
MSMBADDR_2	I	V6	
MSMBADDR_3	I	T7	
MSMBADDR_4	I	V5	
MSMBCLK	I/O	U6	
MSMBDAT	I/O	T6	
MSMBSMODE	I	R6	System
No Connection	See Table 20 for a list of NC pins		

Table 23 89PES10T4BG2 Alphabetical Signal List (Part 1 of 4)

Signal Name	I/O Type	Location	Signal Category
PE0RN00	I	A3	PCI Express
PE0RN01	I	A6	
PE0RN02	I	A12	
PE0RN03	I	A15	
PE0RP00	I	A4	
PE0RP01	I	A7	
PE0RP02	I	A13	
PE0RP03	I	A16	
PE0TN00	O	C3	
PE0TN01	O	C6	

Table 23 89PES10T4BG2 Alphabetical Signal List (Part 2 of 4)

Signal Name	I/O Type	Location	Signal Category
PE0TN02	O	C11	PCI Express (Cont.)
PE0TN03	O	C14	
PE0TP00	O	C2	
PE0TP01	O	C5	
PE0TP02	O	C10	
PE0TP03	O	C13	
PE2RN00	I	T1	
PE2RN01	I	N1	
PE2RP00	I	R1	
PE2RP01	I	M1	
PE2TN00	O	P3	
PE2TN01	O	L3	
PE2TP00	O	R3	
PE2TP01	O	M3	
PE4RN00	I	E18	
PE4RN01	I	H18	
PE4RP00	I	F18	
PE4RP01	I	J18	
PE4TN00	O	E16	
PE4TN01	O	H16	
PE4TP00	O	D16	
PE4TP01	O	G16	
PE6RN00	I	V12	
PE6RN01	I	V9	
PE6RP00	I	V11	
PE6RP01	I	V8	
PE6TN00	O	T12	
PE6TN01	O	T9	
PE6TP00	O	T13	
PE6TP01	O	T10	
PEREFCLKN0	I	A10	
PEREFCLKP0	I	A9	
PERSTN	I	C17	System
REFCLKM	I	U15	PCI Express

Table 23 89PES10T4BG2 Alphabetical Signal List (Part 3 of 4)

Signal Name	I/O Type	Location	Signal Category
REFRES0	I/O	D10	SerDes Reference Resistors
REFRES2	I/O	J4	
REFRES4	I/O	K17	
REFRES6	I/O	V7	
RSTHALT	I	D14	System
SSMBADDR_1	I	P4	SMBus
SSMBADDR_2	I	R4	
SSMBADDR_3	I	U4	
SSMBADDR_5	I	T4	
SSMBCLK	I/O	U3	SMBus
SSMBDAT	I/O	V3	
SWMODE_0	I	A18	System
SWMODE_1	I	B17	
SWMODE_2	I	B18	
$V_{DD}CORE$, $V_{DD}I/O$, $V_{DD}PEA$, $V_{DD}PEHA$, $V_{DD}PETA$	See Table 21 for a listing of power pins.		
V_{SS}	See Table 22 for a listing of ground pins.		

Table 23 89PES10T4BG2 Alphabetical Signal List (Part 4 of 4)

PES10T4BG2 Pinout — Top View

	1	2	3	4	5	6	7	8	9	10	11	12	13	14	15	16	17	18	
A																			A
B																			B
C																			C
D																			D
E																			E
F																			F
G																			G
H																			H
J																			J
K																			K
L																			L
M																			M
N																			N
P																			P
R																			R
T																			T
U																			U
V																			V
	1	2	3	4	5	6	7	8	9	10	11	12	13	14	15	16	17	18	

- $V_{DD}Core$ (Power)
- $V_{DD}I/O$ (Power)
- V_{SS} (Ground)
- $V_{DD}PETA$ (Transmitter Power)
- $V_{DD}PEA$ (Analog Power)
- $V_{DD}PEHA$ (High Analog Power)
- Signals
- No Connect

Advance Information

PES10T4BG2 Package Drawing — 324-Pin BC324/BCG324

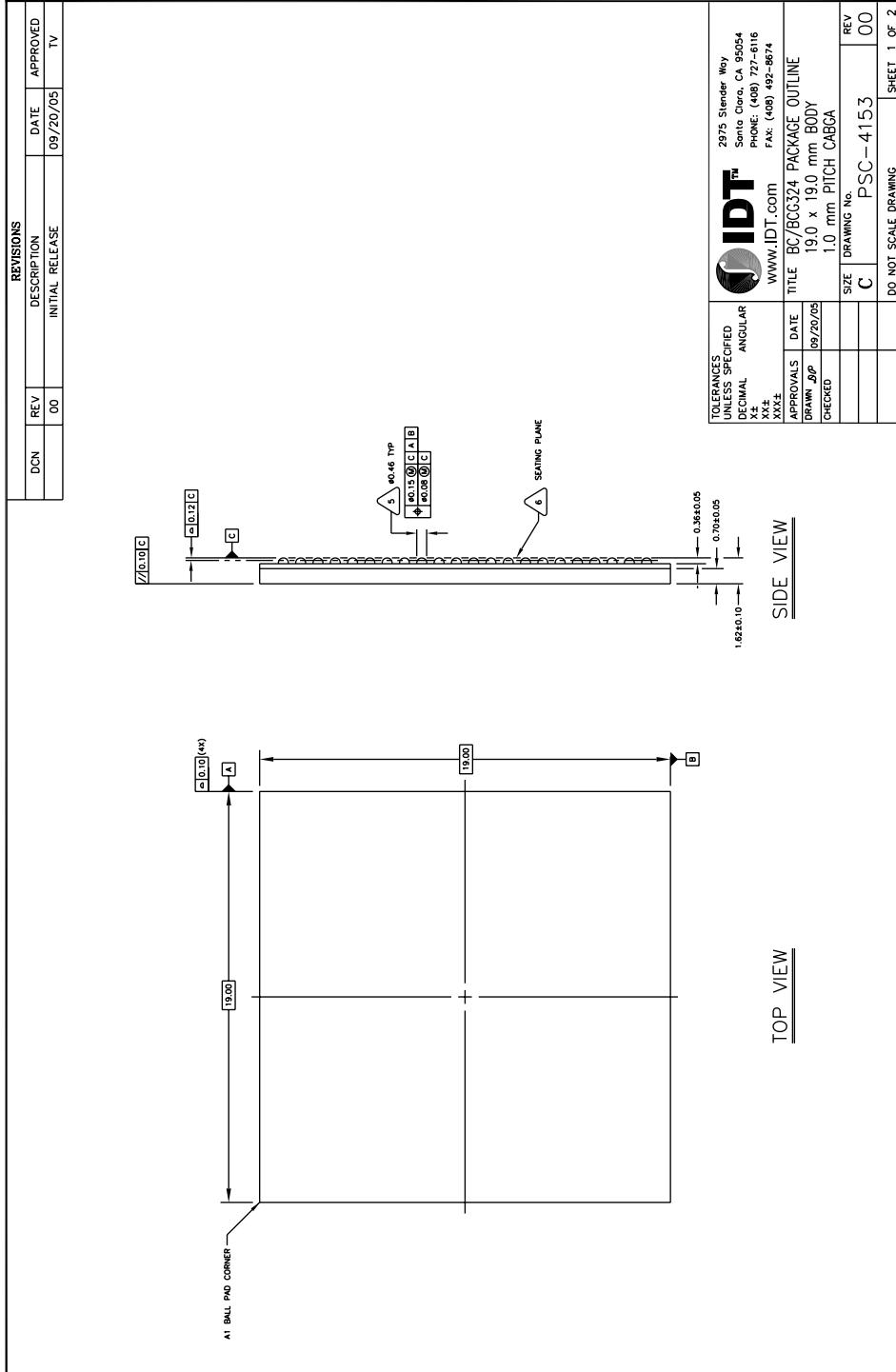

Advance Information

PES10T4BG2 Package Drawing — Page Two

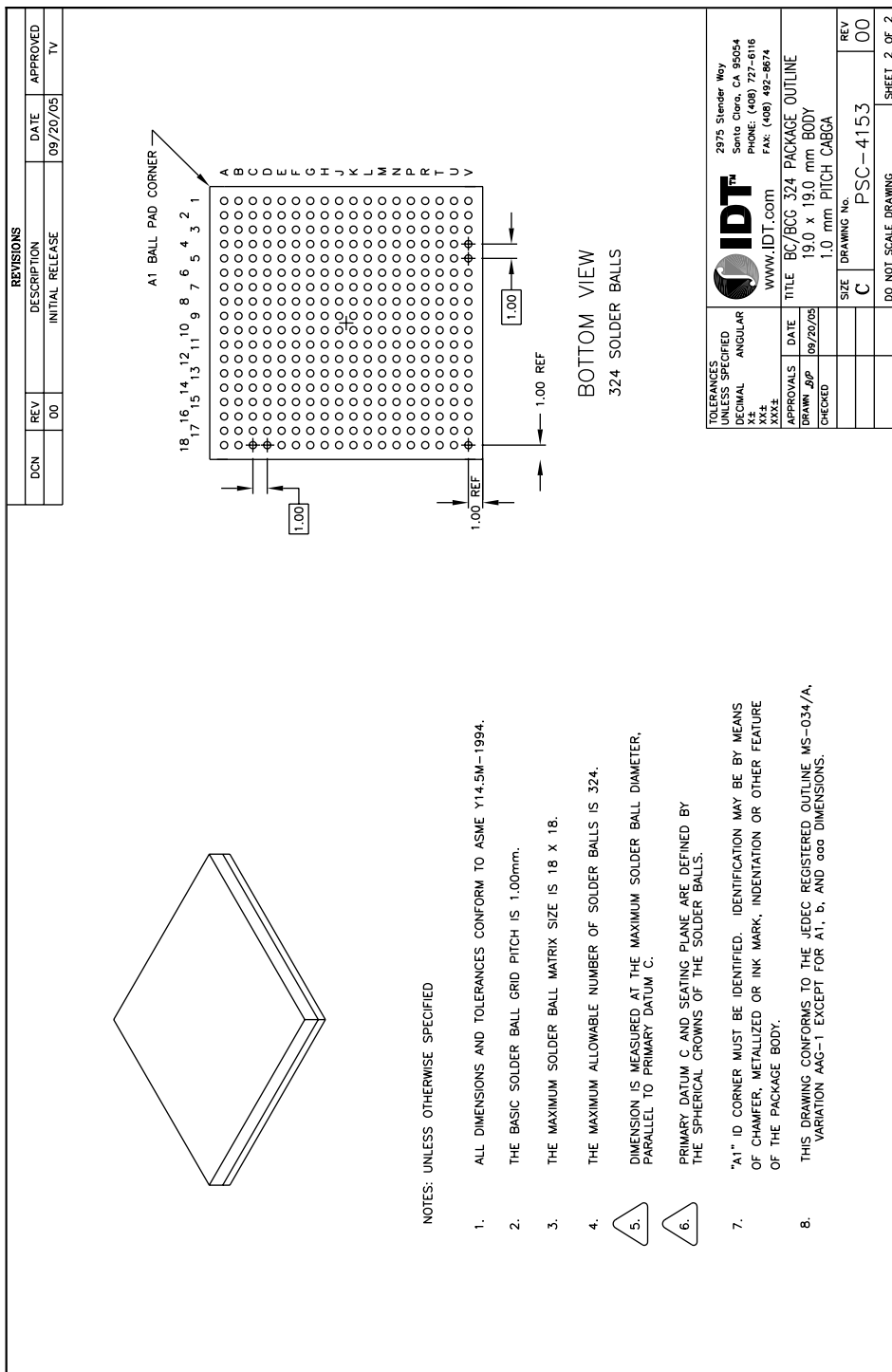

Advance Information

Revision History

July 1, 2009: Initial publication of Advance data sheet.

Advance Information

Ordering Information

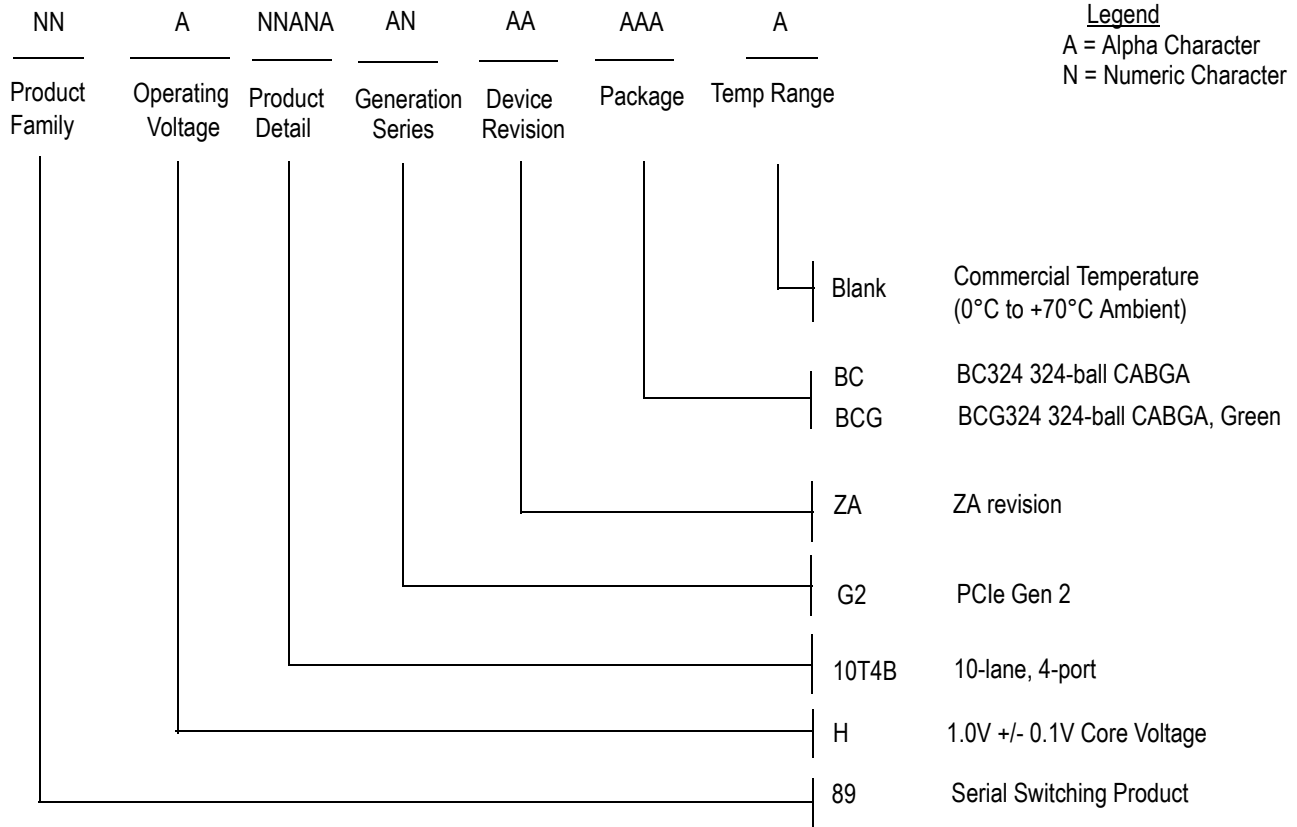

Advance Information

Valid Combinations

- 89H10T4BG2ZABC 324-ball BGA package, Commercial Temperature
- 89H10T4BG2ZABCG 324-ball Green BGA package, Commercial Temperature



CORPORATE HEADQUARTERS
 6024 Silver Creek Valley Road
 San Jose, CA 95138

for SALES:
 800-345-7015 or 408-284-8200
 fax: 408-284-2775
www.idt.com

for Tech Support:
 email: ssdhelp@idt.com
 phone: 408-284-8208

DISCLAIMER Integrated Device Technology, Inc. (IDT) and its subsidiaries reserve the right to modify the products and/or specifications described herein at any time and at IDT's sole discretion. All information in this document, including descriptions of product features and performance, is subject to change without notice. Performance specifications and the operating parameters of the described products are determined in the independent state and are not guaranteed to perform the same way when installed in customer products. The information contained herein is provided without representation or warranty of any kind, whether express or implied, including, but not limited to, the suitability of IDT's products for any particular purpose, an implied warranty of merchantability, or non-infringement of the intellectual property rights of others. This document is presented only as a guide and does not convey any license under intellectual property rights of IDT or any third parties.

IDT's products are not intended for use in life support systems or similar devices where the failure or malfunction of an IDT product can be reasonably expected to significantly affect the health or safety of users. Anyone using an IDT product in such a manner does so at their own risk, absent an express, written agreement by IDT.

Integrated Device Technology, IDT and the IDT logo are registered trademarks of IDT. Other trademarks and service marks used herein, including protected names, logos and designs, are the property of IDT or their respective third party owners.

Copyright 2009. All rights reserved.