



Advanced
Micro
Devices

Am7910/11

WORLD-CHIP® FSK Modem

DISTINCTIVE CHARACTERISTICS

Common Capabilities

- Complete FSK Modem in 28-pin package
- 300-bps full-duplex operation
- 1200-bps half-duplex operation
- 1200-bps full-duplex on four-wire
- Compatible with Bell 103/113/108, Bell 202, CCITT V.21, and V.23
- Available in CDIP, PDIP, and PLCC packages
- Commercial, Industrial and Extended temperature range
- No external filtering required
- All digital signal processing, digital filtering, and A/D-D/A conversion on-chip
- Includes essential RS-232/CCITT V.24 handshake signals on-chip
- Autoanswer capability

Unique Device Capabilities

Am7910

- Dial-up network response times
- Bell 202 with 5-bps back channel
- V.23 with up to 75-bps back channel

Am7911

- Fast response time for leased-line networks
- Bell 202 with 5-bps or 150-bps back channel
- V.23 with up to 150-bps back channel

BLOCK DIAGRAM

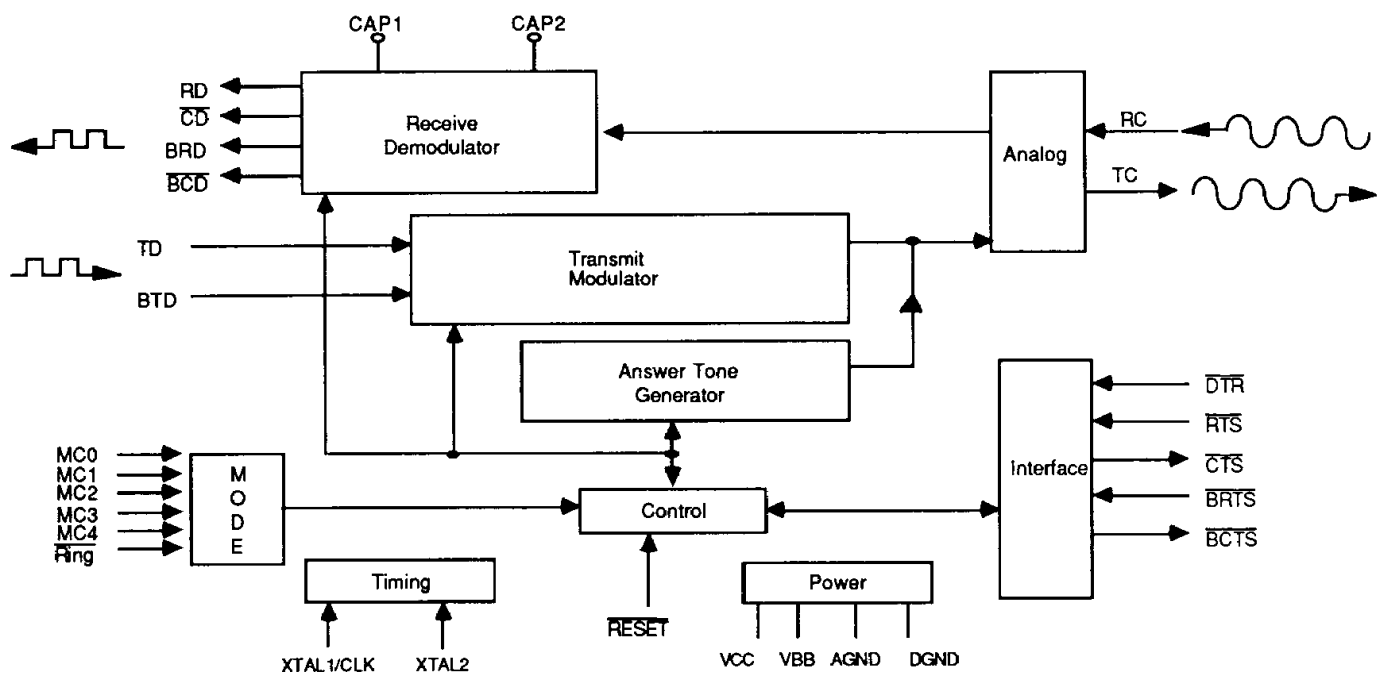

09833C-001

GENERAL DESCRIPTION

Advanced Micro Devices offers a family of high-performance FSK modem chips that may be easily integrated in system designs to interface terminals and workstations to the Telephone Network. The product family consists of:

–Am7910 FSK Modem

–Am7911 FSK Modem

–Am79101 Autodial FSK Modem

Am7910 and Am7911

AMD currently offers three single-chip modems in the Frequency Shift Keying (FSK) series including the Am7910, the Am7911 and the Am79101. This family of modems includes most of the building blocks required for a complete communication system. Some of the

on-chip features include: analog-to-digital and digital-to-analog converters, internal crystal oscillator, and the essential RS-232/CCITT V.24 terminal control signals with TTL levels. A DAA (Data Access Arrangement) or acoustic coupler must be supplied externally to provide the Phone Line Interface.

The FSK modem chips all have the same basic structure as shown in the simplified block diagram. The Am7910 and the Am7911 differ mainly in timing parameters with the Am7911 being tailored for better performance in leased-line, multidrop applications. The Am7911 also includes an extended set of modem selection modes.

The Am79101 is described in a separate data sheet (order no. 09833).

TABLE OF CONTENTS

Distinctive Characteristics	1
General Description	2
Connection Diagram	4
Ordering Information	5
Pin Description	6
Functional Description	10
Call Establishment	14
Data Transmission	16
Full-Duplex	16
Half-Duplex	16
Main Channel	16
Back Channel	16
Data Reception	19
Full-Duplex	19
Half-Duplex	19
Timing Parameters	21
Loopback	27
Clock Generation	27
Absolute Maximum Ratings	30
Operating Ranges	30
DC Characteristics	31
Switching Characteristics	33
Applications	35
Physical Dimensions	39

CONNECTION DIAGRAMS

Top View

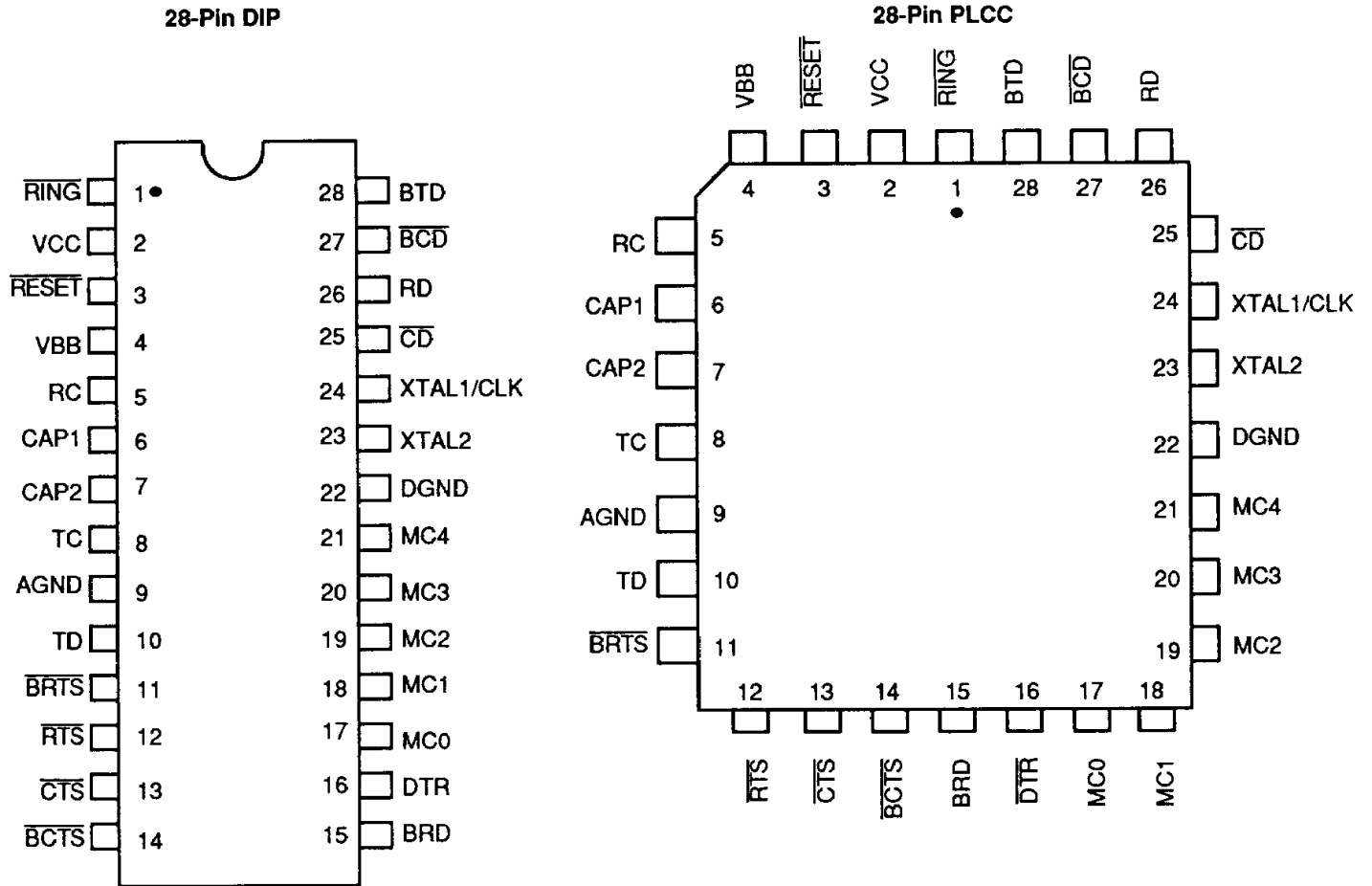

Note: Pin 1 is marked for orientation.

09560-3B

ORDERING INFORMATION

Standard Products

AMD standard products are available in several packages and operating ranges. The ordering number (Valid Combination) is formed by a combination of:

- a. Device Number
- b. Speed Option (If applicable)
- c. Package Type
- d. Temperature Range
- e. Optional Processing

AM7910/11

D

C

B

a. DEVICE NUMBER/DESCRIPTION

Am7910/11
WORLD-CHIP FSK Modem

e. OPTIONAL PROCESSING

Blank = Standard Processing
B = Burn-in

d. TEMPERATURE RANGE

C = Commercial (0°C to +70°C)
I = Industrial (-40°C to +85°C)
E = Extended (-55°C to +125°C)

c. PACKAGE TYPE

P = 28-Pin Plastic DIP (PD 028)
D = 28-Pin Ceramic DIP (CD 028)
J = 28-Pin PLCC (PL 028)

b. SPEED OPTION

Not Applicable

Valid Combinations	
AM7910 AM7911	PC, JC, DC, DCB, DI, DIB, DE, DEB

Valid Combinations

Valid Combinations list configurations planned to be supported in volume for this device. Consult the local AMD sales office to confirm availability of specific valid combinations, to check on newly released combinations, and to obtain additional data on AMD's standard military grade products.

PIN DESCRIPTION

All digital inputs and outputs are TTL-compatible unless otherwise noted.

Setup Controls

AGND

Analog signal ground pin (for TRANSMITTED CARRIER and RECEIVED CARRIER).

$\overline{\text{BCD}}$

Back Carrier Detect

This line is equivalent to $\overline{\text{CD}}$ for the main channel, except it belongs to the back channel. $\overline{\text{BCD}}$ is meaningful only when a 202 or V.23 mode is selected by MC0–MC4. For the V.23 back channel mode or the 202 150-bps (or 75-bps) back channel mode, $\overline{\text{BCD}}$ activates when either the Mark or Space frequency appears with sufficient level at the RC (Received Carrier) input.

For the 202 5-bps back channel mode, $\overline{\text{BCD}}$ turns on in response to a 387 Hz tone of sufficient level at the RC input. In this case $\overline{\text{BCD}}$ is equivalent to the secondary received line signal detector for 202 S/T modems, or supervisory received data for 202 C/D modems.

$\overline{\text{BCTS}}$

Back Clear to Send

This line is equivalent to $\overline{\text{BCTS}}$ for the main channel, except it belongs to the back channel. $\overline{\text{BCTS}}$ is meaningful only when a V.23 mode or 202 150-bps (or 75-bps) back channel mode is selected by MC0–MC4. This signal is not used in the 202 5-bps back channel mode.

BRD

Back Received Data

This line is equivalent to RD for the main channel, except that it applies only to the back channel. BRD is meaningful only for the V.23 or the 202 back channel modes. Under the following conditions this output is clamped High:

- V.21/103 modes
- $\overline{\text{BCD}}$ High
- $\overline{\text{DTR}}$ High
- $\overline{\text{BRTS}}$ Low and $\overline{\text{RTS}}$ High in V.23 or 202 150-bps modes only
- During autoanswer sequence.

$\overline{\text{BRTS}}$

Back Request to Send

Since the 1200-bps modem configurations (Bell 202 and CCITT V.23) permit only half-duplex operation over two-wire lines, a low baud rate back channel is provided for simultaneous transmission in the reverse direction. $\overline{\text{BRTS}}$ is equivalent to $\overline{\text{RTS}}$ for the main channel, except

that it belongs to the back channel. Since the modem contains a single transmitter, $\overline{\text{RTS}}$ and $\overline{\text{BRTS}}$ should not be asserted simultaneously. $\overline{\text{BRTS}}$ is meaningful only when a 202 or V.23 mode is selected by MC0–MC4. In all other modes, it is ignored.

For the V.23 modes and the 202 150-bps (or 75-bps) back channel mode, the frequency appearing at the TC (Transmitted Carrier) output pin is determined by a Mark or Space at the BTD input.

For the 202 5-bps back channel mode, a frequency of 387 Hz appears at TC when $\overline{\text{BRTS}}$ is Low and BTD is High. No energy (0.0 volts) appears at TC when $\overline{\text{BRTS}}$ is High. BTD should be fixed High for 202 back channel transmission. $\overline{\text{BRTS}}$ then is equivalent to the transmitted data. $\overline{\text{BRTS}}$ is the Secondary Request-to-Send for 202 S/T modems, or the Supervisory Transmitted Data for 202 C/D modems.

BTD

Back Transmitted Data

This line is equivalent to TD for the main channel, except it belongs to the back channel. BTD is meaningful only when a 202 or V.23 mode is selected by MC0–MC4. For 202 5-bps back channel transmission of on/off keying, BTD should be fixed at a High level.

CAP₁, CAP₂

Connection points of external capacitor/resistor required for proper operation of the on-chip analog-to-digital converter. Recommended values are:

$$C = 2000 \text{ pF} \pm 10\%, \\ R = 910 \text{ ohms} \pm 10\%.$$

$\overline{\text{CD}}$

Carrier Detect

A Low on this output indicates that a valid carrier signal is present at the receiver and has been present for at least a time (t_{CDON}). A High on this output signifies that no valid carrier is being received and has not been received for a time (t_{CDOFF}). $\overline{\text{CD}}$ looks for energy in the receive bandwidth. $\overline{\text{CD}}$ is Low when the receive signal is above a threshold limit (V_{CDON}) and High when the level of the received signal is below V_{CDOFF} .

$\overline{\text{CTS}}$

Clear to Send

This output goes Low at the end of a delay (t_{RCON}) initiated when $\overline{\text{RTS}}$ goes Low. Actual data to be transmitted should not be presented to the TD (Transmit Data) input until a Low is indicated on the $\overline{\text{CTS}}$ output. This gives the receiving modem (on the other end of the phone line) enough time to recognize a valid carrier signal before

data is transmitted. Normally the user should force the TD input High whenever \overline{CTS} is High so a Mark will be sent during the (t_{RCON}) time. \overline{CTS} goes High at the end of a delay initiated when \overline{RTS} goes High (t_{RCOFF}). \overline{CTS} will never be Low when \overline{DTR} is High.

DGND

Digital signal ground pin.

DTR

Data Terminal Ready

A Low level on this input indicates the data terminal is ready to send and/or receive data via the modem. This signal is gated with all other TTL inputs and outputs so that a Low level enables these signals as well as the internal control logic. A High disables all TTL I/O pins and the internal logic.

When \overline{DTR} is High, the modem handshake state machine is reset to initial conditions. This is the only way to reset the state machine and must be done after power up. The state machine does not automatically power up to a known state. If \overline{DTR} is permanently enabled (Low), the state machine will simply run from wherever it powers up. This can result in abnormal behavior such as an unusually short \overline{RTS} - \overline{CTS} delay due to lack of \overline{DTR} initialization.

In order to change the modem mode while the modem is powered up, use the following sequence:

1. Take \overline{DTR} High
2. Change mode inputs to desired configuration
3. Wait at least 100 μ s
4. Take \overline{DTR} Low

The mode inputs perform some hardware functions, and they are also sampled periodically by the state machine. If the mode inputs are changed without the re-initialization using \overline{DTR} , the state machine will not completely change to the new mode.

MC0–MC4

Mode Controls

The FSK modem family has multiple built-in modem modes selectable by the user through a set of Mode Control Pins. Table 1 lists the modem modes, mode-control pin states, and the product containing a particular mode.

The loopback modes set the receiver channel signal processing band to that of the transmit channel. No internal connection is made. The user must connect the TC pin to the RC pin if analog loopback is required (see Figure 1).

For digital loopback, external connection of the RD and TD pins is required.

With the Am7910/11, loopback modes can also be used to achieve full-duplex, 1200-bps communication. In CCITT V.23 or Bell 202 loopback modes, the modem can transmit and receive at 1200 bps using a four-wire

configuration (transmit over one channel and receive on another). See the System Configuration section for details.

RC

Received Carrier

This input is the analog signal received from the phone line. The modem extracts the information contained in this modulated carrier and converts it into a serial data stream for presentation at the RECEIVED DATA (BACK RECEIVED DATA) output.

RD

(Received Data)

Data bits demodulated from the RC (Received Carrier) input are available serially at this output; High (Mark) indicates logical 1 and Low (Space) indicates logical 0.

Under the following conditions, this output is forced to logical 1, because the data may be invalid:

- When \overline{CD} is High
- During the internal squelch delay at half-duplex line turnaround (202 and V.23 modes only)
- During soft carrier turnoff at half-duplex line turnaround (202 and V.23 soft turn-off modes only)
- When \overline{DTR} is High
- When \overline{RTS} is Low and \overline{BRTS} is High in 202 and V.23 modes only
- During the autoanswer sequence

RESET

This input signal is for a reset circuit which operates in either of two modes. Refer to Figure 15 and Figure 16 for these two modes. The Am7910/11 should be reset upon initial application of power.

Ring

This input signal permits autoanswer capability by responding to a ringing signal from a Data Access Arrangement. If a ringing signal is detected (\overline{Ring} = Low) and \overline{DTR} is Low, the modem begins a sequence to generate an answer tone at the TC output.

RTS

Request to Send

A Low on this input instructs the modem to enter the transmit mode. This input must remain Low for the duration of data transmission. This signal has no effect if \overline{DTR} is set High (disabled). A High level on this input turns off the transmitter.

TC

Transmitted Carrier

This analog output is the modulated carrier to be conditioned and sent over the phone line.

TD**Transmitted Data**

Data bits to be transmitted are presented to this input serially; High (Mark) corresponds to logical 1 and Low (Space) corresponds to logical 0. This data determines which frequency appears at any instant at the TC (Transmitted Carrier) output pin (Table 3). No signal appears at the TC output unless \overline{DTR} is Low and \overline{RTS} is Low.

V_{BB}

-5-volt power supply ($\pm 5\%$).

V_{CC}

+5-volt power supply ($\pm 5\%$).

XTAL₁, XTAL₂

Master timing of the modem is provided by either a crystal connected to these two inputs or an external clock inserted into XTAL₁. The value of the crystal or the external clock frequency must be 2.4576 MHz $\pm 0.1\%$.

Table 1. Am7910/11 Mode Control Lines

7910	7911	MC4	MC3	MC2	MC1	MC0	Description
X	X	0	0	0	0	0	Bell 103 originate 300 bps full-duplex
X	X	0	0	0	0	1	Bell 103 answer 300 bps full-duplex
X	X	0	0	0	1	0	Bell 202 1200 bps half-duplex
X	X	0	0	0	1	1	Bell 202 with equalizer
X	X	0	0	1	0	0	CCITT V.21 orig 300 bps full-duplex
X	X	0	0	1	0	1	CCITT V.21 ans 300 bps full-duplex
X	X	0	0	1	1	0	CCITT V.23 M2 1200 bps half-duplex
X	X	0	0	1	1	1	CCITT V.23 M2 with equalizer
X		0	1	0	0	0	CCITT V.23 M1 (1) 600 bps half-duplex
	X	0	1	0	0	0	CCITT V.23 M1 (2) 600 bps half-duplex
		0	1	0	0	1	Reserved
	X	0	1	0	1	0	Bell 202 with 150 bps back channel
	X	0	1	0	1	1	Bell 202 with 150 bps back channel and equalizer
	X	0	1	1	0	0	CCITT V.23 M1 (2) with soft turn-off (STO)
		0	1	1	0	1	Reserved
	X	0	1	1	1	0	CCITT V.23 M2 (2) with STO
	X	0	1	1	1	1	CCITT V.23 M2 (2) with STO and equalizer
X	X	1	0	0	0	0	Bell 103 orig. loopback
X	X	1	0	0	0	1	Bell 103 answer loopback
X	X	1	0	0	1	0	Bell 202 main loopback
X	X	1	0	0	1	1	Bell 202 with equalizer loopback
X	X	1	0	1	0	0	CCITT V.21 orig. loopback
X	X	1	0	1	0	1	CCITT V.21 ans. loopback
X	X	1	0	1	1	0	CCITT V.23 M2 main loopback
X	X	1	0	1	1	1	CCITT V.23 M2 with equalizer loopback
X	X	1	1	0	0	0	CCITT V.23 M1 main loopback
X		1	1	0	0	1	CCITT V.23 (1) back loopback
	X	1	1	0	0	1	CCITT V.23 (2) back loopback
	X	1	1	0	1	0	Bell 202 (2) back loopback
		1	1	0	1	1	Reserved
		1	1	1	0	0	Reserved
		1	1	1	0	1	Reserved
		1	1	1	1	0	Reserved
		1	1	1	1	1	Reserved

NOTE: Reserved modes should not be entered.

(1) up to 75 baud back channel
(2) up to 150 baud back channel

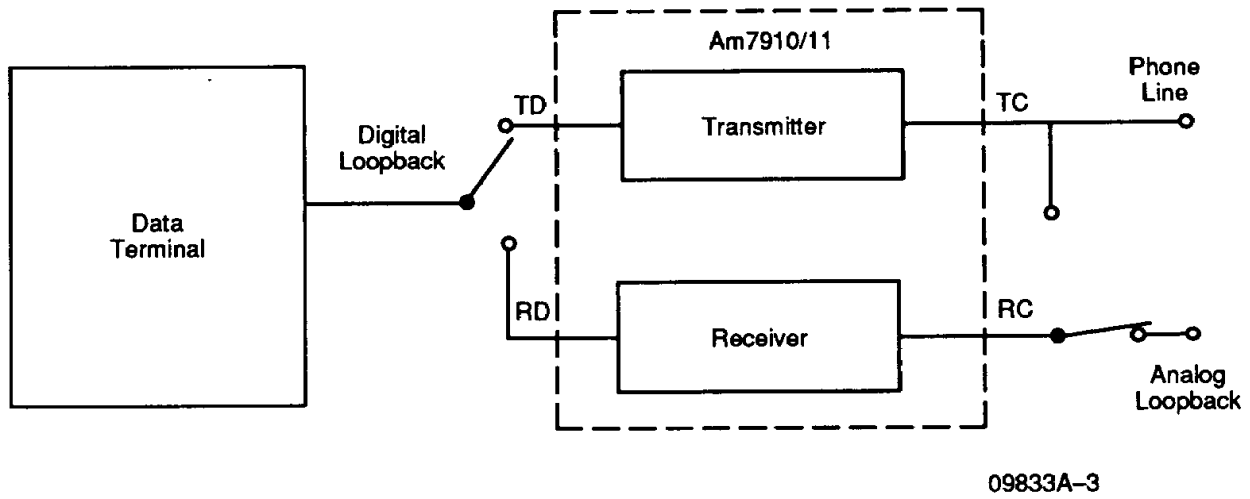

Figure 1. Analog Loopback

FUNCTIONAL DESCRIPTION

The modem consists of three main sections shown in the block diagram—Transmitter, Receiver, and Interface Control.

Transmitter (Modulator)

In the data mode, the transmitter, shown in Figure 2, receives binary digital data from a source such as a UART and converts the data to an analog signal using Frequency Shift Keying (FSK) modulation. This analog signal is applied to the phone line through a DAA or an

acoustic coupler. FSK is a modulation technique which encodes one bit per baud. A logical 1 applied to the TD input causes a sine wave at a given frequency to appear at the analog TC output. A logical 0 applied to TD causes a sine wave of a different frequency to appear at TC. As the data at TD switches between logical 1 and 0, TC switches between the two frequencies. In the AMD modem this switching between frequencies is phase continuous. The frequencies themselves are digitally synthesized sine functions.

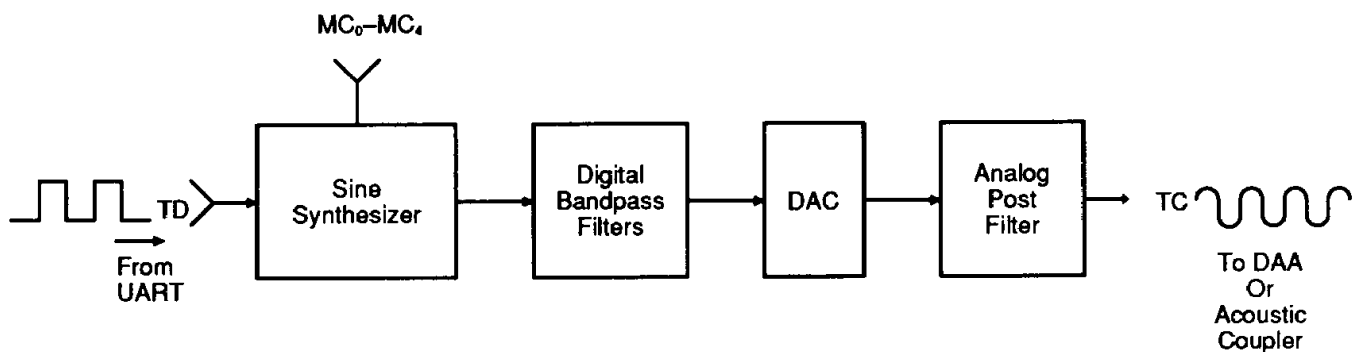

09833A-4

Figure 2. Transmitter Block Diagram

The frequencies for each modem configuration available in the FSK modem are listed in Table 3.

The process of switching between two frequencies (as in FSK) generates energy at many more frequencies than the two used in the modulation. All the transmitted information can be recovered from a frequency band "B" Hz wide.

where B = bit rate or maximum rate of change of the digital data at TD.

This band is centered about a frequency (f_c)

where $f_c = (f_1 + f_2)/2$

(f_1 = lower of two FSK frequencies)

(f_2 = higher of two FSK frequencies)

In addition to this primary information band, there are side bands containing redundant information. It is desirable to attenuate these bands for two reasons:

1. The phone companies have specifications on the amount of energy allowed in certain frequency bands on the line.
2. If two independent information channels are present simultaneously on the line (for example, 300-bps full-duplex or 1200-bps half-duplex with back channel), the redundant transmitter components may fall in the frequency band of the local receiver channel and interfere with detection. In the Am7910/11 these redundant and undesirable components are attenuated by digital bandpass filters.

Following the digital bandpass filters, the filtered FSK signal is converted to an analog signal by an on-chip Digital-to-Analog (D/A) converter operating at a High sampling rate. This analog FSK signal is made smooth by a simple on-chip analog low-pass filter.

Receiver (Demodulator)

A simplified block diagram of the Am7910/11 FSK receiver is shown in Figure 3. Data transmitted from a remote-site modem over the phone line is a FSK-modulated analog carrier. This carrier is applied to the RC pin via a DAA or an acoustic coupler. The first stage of the demodulator is a simple on-chip analog low-pass anti-alias filter. The output of this is converted into digital form and filtered by digital bandpass filters to improve the signal-to-noise ratio and reject other independent channel frequencies associated with the phone line in the case of full-duplex configuration. In the Data mode, the bandpass-filtered output is digitally demodulated to recover the binary data to appear at the RD pin. A \overline{CD} signal is also digitally extracted from the received line carrier to indicate valid data.

The short control signal delays on the Am7911 make it attractive for use over multidrop networks. In such a system, a central site station polls a number of remote stations and so the short \overline{RTS} - \overline{CTS} delays allow efficient line utilization when polling.

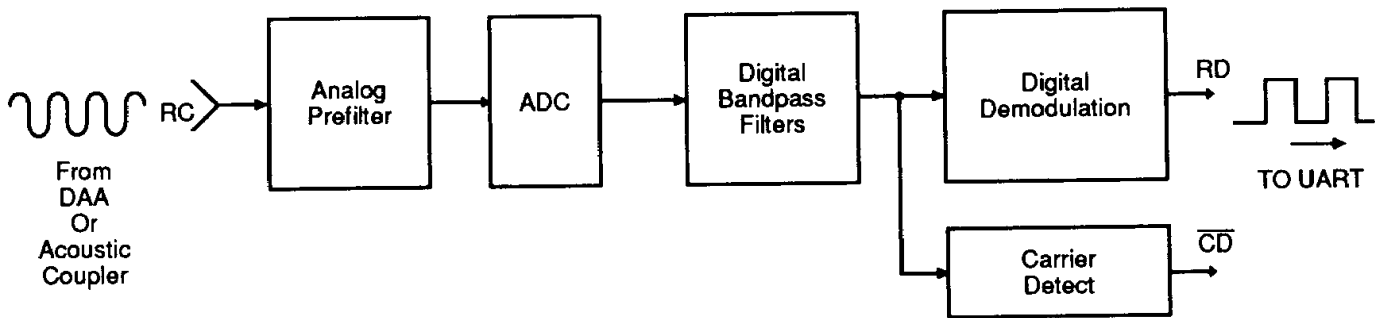

09833A-5

Figure 3. Receiver Block Diagram

Interface Control

This section controls the handshaking between the modem and the local terminal. It consists primarily of delay-generation counters, two state machines for controlling transmission and reception, and mode-control-decode logic. Proper transmit frequencies and transmit/receive filters are selected according to the specified modem type or function in the Data or Call mode. Inputs to and outputs from this section are as follows:

- $\overline{\text{Ring}}$
- MC0-MC4
- $\overline{\text{DTR}}$ (Data Terminal Ready)
- $\overline{\text{RTS}}$ (Request to Send) (Main and Back)
- $\overline{\text{CTS}}$ (Clear to Send) (Main and Back)
- $\overline{\text{CD}}$ (Carrier Detect) (Main and Back)
- Reset

Internal logic clamps the handshake signals to different levels under certain conditions (for example, initial conditions).

When Bell 103/113 and V.21 modem configurations are selected, the back channel signals are non-functional.

Figures 6 and 7 depict the sequencing of the two state machines. State machine 1 implements main or back channel transmission. State machine 2 implements reception on main or back channel. Tables 4 and 5 list the timing parameters, and Figures 10 through 13 show the handshake timing diagrams for the various modem modes.

The state machine powers-on after reset to the state labeled INITIAL CONDITIONS. Handshake signals are set to or assumed to be at the levels listed in Table 2. The machine waits for $\overline{\text{DTR}}$ to go Low. Whenever $\overline{\text{DTR}}$ is changed from Low to High, each state machine and the external signals return to the initial conditions within

25 ms. After $\overline{\text{DTR}}$ is set Low, the Am7910/11 becomes operational as a modem and the state machines proceed as depicted in the flowcharts.

The definitions of the terms full-duplex and half-duplex used in these flowcharts are depicted in Figures 4 and 5. Full-duplex applies to all 103/113 and V.21 modes. Half-duplex applies to 202 and V.23 modes, both main and back channels.

Full-Duplex—Data can be transmitted and received simultaneously at 300 bps. Two independent 300-Hz channels are frequency multiplexed into the 3000-Hz bandwidth of the phone line. The Am7910/11 configurations for the Bell 103/113 and CCITT V.21 can be operated full-duplex.

Half-Duplex—In half-duplex with back channel, the modem may transmit at 1200/600 bps and receive at 5/75/150 bps. Alternately it may transmit at 5/75/150 bps and receive at 1200/600 bps. Examples are Bell 202 and CCITT V.23.

Table 2. Initial Conditions

$\overline{\text{Ring}}$	High
$\overline{\text{DTR}}$ (Data Terminal Ready)	High
$\overline{\text{RTS}}$ (Request to Send)	High
$\overline{\text{CTS}}$ (Clear to Send)	High
TD (Transmitted Data)	Ignored
$\overline{\text{BRTS}}$ (Back Channel Request-to-Send)	High
$\overline{\text{BCTS}}$ (Back Channel Clear-to-Send)	High
BTD (Back Channel Transmitted Data)	Ignored
$\overline{\text{CD}}$ (Carrier Detect)	High
RD (Received Data)	High
$\overline{\text{BCD}}$ (Back Channel Carrier Detect)	High
BRD (Back Channel Received Data)	High

Table 3. Frequency Parameters

Modem Mode	Baud Rate (bps)	Duplex	Transmit Frequency		Receive Frequency	
			Space (Hz)	Mark (Hz)	Space (Hz)	Mark (Hz)
Bell 103 Originate	300	Full	1070	1270	2025	2225
Bell 103 Answer	300	Full	2025	2225	1070	1270
CCITT V.21 Originate	300	Full	1180	980	1850	1650
CCITT V.21 Answer	300	Full	1850	1650	1180	980
CCITT V.23 Mode 1	600	Half	1700	1300	1700	1300
CCITT V.23 Mode 2	1200	Half	2100	1300	2100	1300
CCITT V.23 Mode 2 Equalized	1200	Half	2100	1300	2100	1300
Bell 202	1200	Half	2200	1200	2200	1200
Bell 202 Equalized	1200	Half	2200	1200	2200	1200
CCITT V.23 Back	75/150	—	450	390	450	390
Bell 202 5 bps Back	5	—	*	*	**	**
Bell 202 150 bps Back	150	—	487	387	487	387

All Bell 202 modes and V.23			
Soft Turn-off modes	Soft Turn-off Tone	=	900 Hz
Bell 103	Answer Tone	=	2225 Hz
V.21 and V.23	Answer Tone	=	2100 Hz
Bell 202	Answer Tone	=	2025 Hz

* $\overline{\text{BRTS}}$ Low) and (BTD High) : 387 Hz at TC.

* $\overline{\text{BRTS}}$ High) or (BTD Low) : 0 Volts at TC.

** 387 Hz at RC: $\overline{\text{BCD}}$ Low.

** No 387 Hz at RC: $\overline{\text{BCD}}$ High

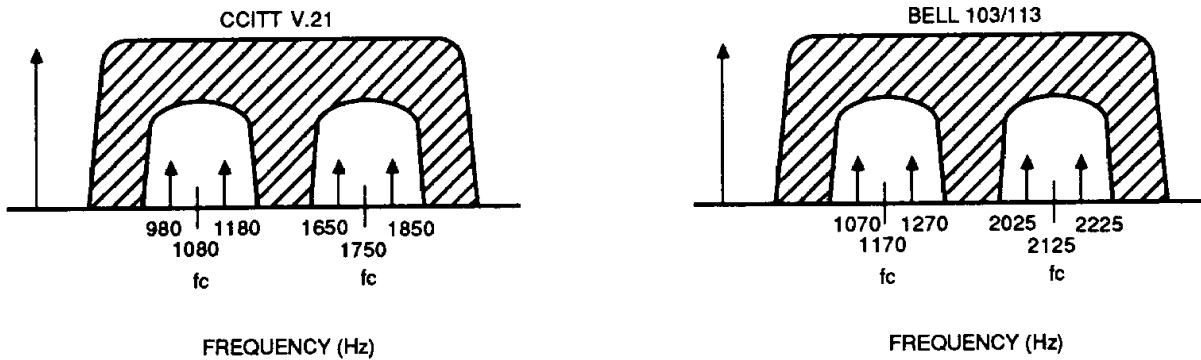

09833A-6

Note: Full-duplex applies to all 103/113 and V.21 modes.

Figure 4. Full-Duplex Channel Assignments

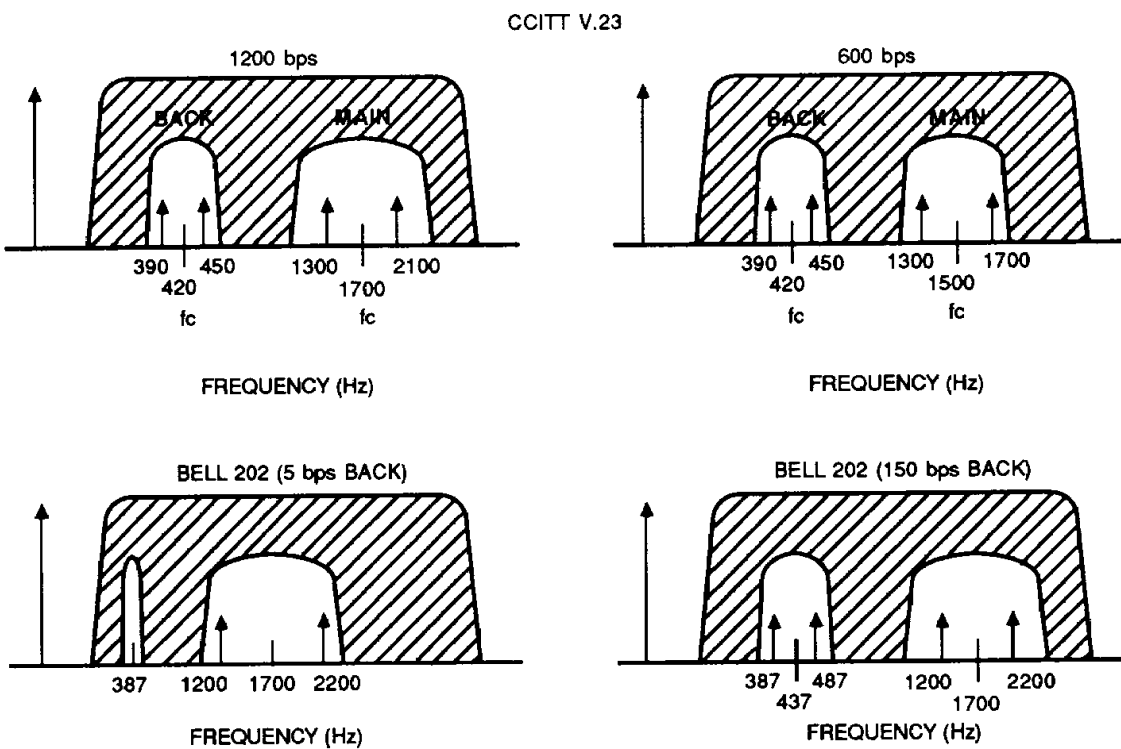

09833A-7

Note: Half-duplex applies to 202 and V.23 modes, both main and back channels.

Figure 5. Half-Duplex Channel Assignments

CALL ESTABLISHMENT

Before two modems can exchange data, an electrical connection through the phone system must be established. Although it may assist in call establishment, a modem typically does not play a major role. A call may be originated manually or automatically and it may be answered manually or automatically.

Manual Calling—Manual calling is performed by a person who dials the number, waits for an answer, then places the calling modem into data transmission mode.

Automatic Calling—Automatic calling is typically performed by an automatic calling unit (ACU) which generates the appropriate dialing pulse or dual-tone sequence required to call the remote (called) modem. The ACU also has the ability to detect an answer tone from the called modem and place the calling modem into data transmission mode.

Manual Answering—Manual answering is performed by a person who hears the phone ring, lifts the receiver, causes the called modem to send an answer tone to the calling modem, and places the called modem into data transmission mode.

Automatic Answering—Automatic answering is performed by a called modem with a data access arrangement (DAA). The DAA detects a ringing signal, takes the phone circuit off-hook (corresponding to lifting the receiver) and instructs the called modem to commence the autoanswer sequence. Next the called modem sends out silence on the line, followed by an answer tone. When this tone is detected by the calling modem, the connection is considered to have been established.

The modem provides assistance for automatic answering through the $\overline{\text{Ring}}$ signal as follows. Observe the

upper right-hand portion of Figure 6. Assume that $\overline{\text{DTR}}$ has recently been asserted to cause exit from the initial conditions. Note that if $\overline{\text{DTR}}$ remains OFF, $\overline{\text{Ring}}$ is ignored. Assume also that $\overline{\text{RTS}}$ and $\overline{\text{BRTS}}$ are OFF and that the mode control lines (MC0–MC4) select a normal modem configuration, not a loopback mode. Automatic answering is initiated by receipt of a Low level at the $\overline{\text{Ring}}$ input, causing entrance to the autoanswer sequence depicted in Figure 8.

The modem outputs silence (0.0 volts) at its Transmitted Carrier (TC) output for a time, t_{SIL2} for the V.21 and V.23 modes. The $\overline{\text{CD}}$ pin is clamped OFF and the RD signal is therefore clamped to a Mark (High) during the autoanswer sequence. Upon completion of the answer tone, $\overline{\text{CD}}$ is released. If the mode lines (MC0–MC4) select a 202 or V.23 mode, the transmit filters are set to the forward channel and the receive filters are set to the back channel during the autoanswer sequence.

At the end of the autoanswer sequence, a return is made to point A in the loop at the upper right-hand portion of Figure 6. Note that since the answer flag has been set, the autoanswer sequence cannot be entered again unless $\overline{\text{DTR}}$ is first turned OFF, then ON. At this point the phone line connection has been established and data transmission or reception may begin.

The $\overline{\text{Ring}}$ input may be activated from a conditioned DAA Ring indicator output for automatic answering or it may be activated by a switch for manual answering. Tying $\overline{\text{Ring}}$ High will disable the autoanswer function of the modem.

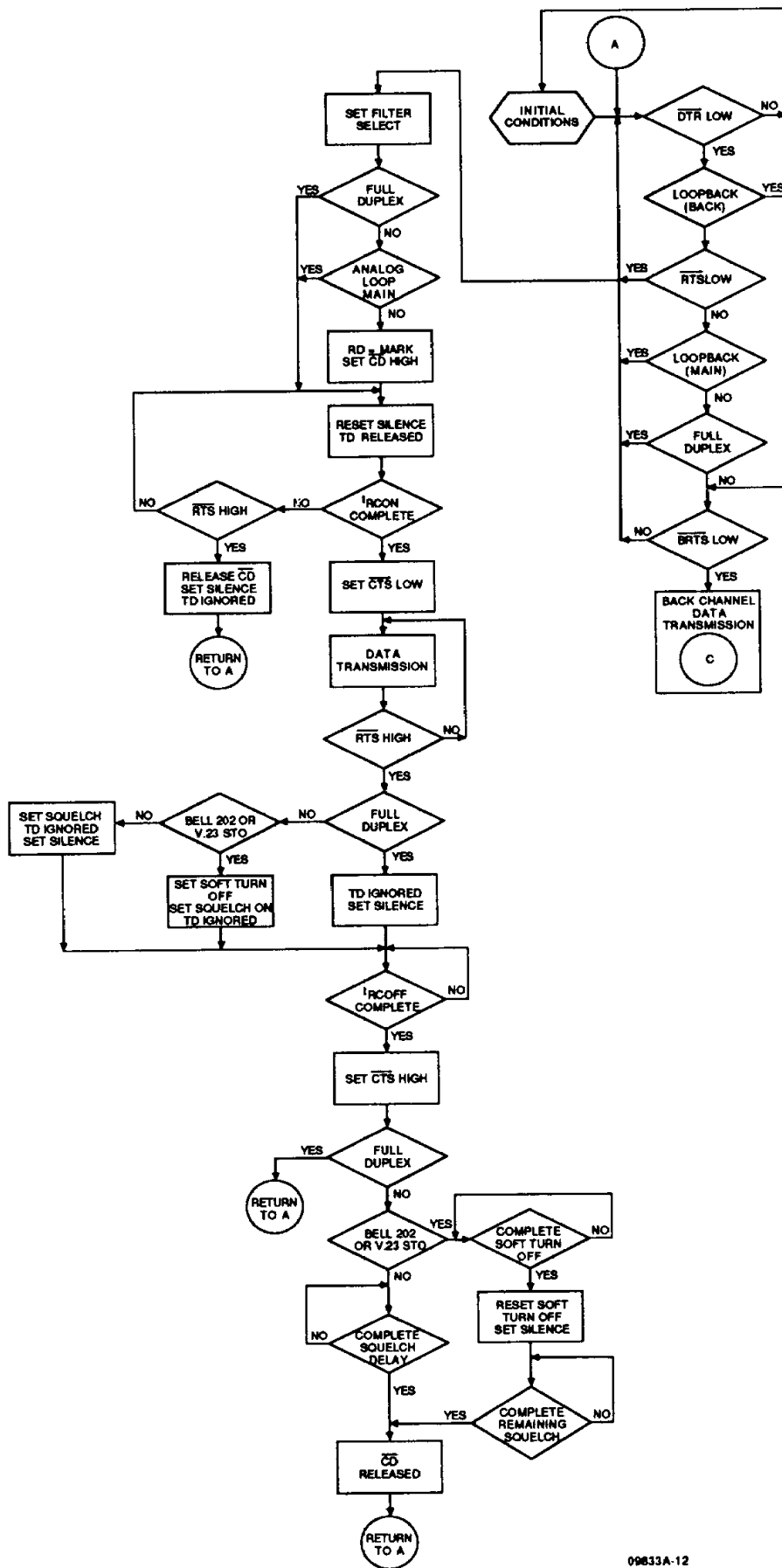

09833A-12

Figure 6. Transmit Main Channel State Diagram

DATA TRANSMISSION

Full-Duplex

Following call establishment, full-duplex data transmission can be started by either the called or calling modem. In other words, if the connection has been established and the modem is looping through point A in Figure 6, it no longer matters which is the called and which is the calling modem. Data transmission is initiated by asserting $\overline{\text{RTS}}$. At this time the TD input will be released and a modulated carrier can appear at the TC output. Following a delay, t_{RCON} , $\overline{\text{CTS}}$ will turn ON. At this time, data may be transmitted through the TD input. It is a common protocol for the user to always present a Mark at the TD input before $\overline{\text{RTS}}$ is asserted and during the t_{RCON} delay.

Data transmission continues until $\overline{\text{RTS}}$ is turned OFF. Following a short delay, t_{RCOFF} , $\overline{\text{CTS}}$ turns OFF. As soon as $\overline{\text{RTS}}$ goes OFF, the TD input is ignored and the TC output is set to 0.0 volts (silence). After $\overline{\text{CTS}}$ turns OFF, the state machine returns to point A in Figure 6.

Half-Duplex

When a half-duplex mode is selected (202 or V.23), data transmission can be either on the main channel at 1200/600 baud or on the back channel at 5/75/150 baud. In normal half-duplex operation a single modem is either transmitting on the main and receiving on the back channel or vice versa. In the modems, control of the transmitter and receiver filters to the proper channel is performed by $\overline{\text{RTS}}$. When $\overline{\text{RTS}}$ is asserted, the transmitter filters and synthesizer are set to transmit on the main channel; the receiver filters are set to receive on the back channel. Therefore, whenever $\overline{\text{RTS}}$ is on, $\overline{\text{BRTS}}$ should not be asserted since the transmitter cannot be used for the back channel. When $\overline{\text{RTS}}$ is OFF and a half-duplex mode is selected, the transmitter filters and synthesizer are set to the back channel; the receiver filters are set to the main channel. If $\overline{\text{RTS}}$ and $\overline{\text{BRTS}}$ are asserted simultaneously, $\overline{\text{RTS}}$ will take precedence. However, if $\overline{\text{BRTS}}$ is asserted before $\overline{\text{RTS}}$ and the back channel data transmission sequence has been entered (Figure 7), $\overline{\text{RTS}}$ will be ignored until $\overline{\text{BRTS}}$ is turned OFF.

The state machine sequences for main and back channel transmission differ slightly and are depicted in Figures 6–9. Assume the state machine is idling through point A in Figure 6.

Main Channel

This transmission sequence is entered if a 202 or V.23 mode is selected and $\overline{\text{RTS}}$ is asserted. Since the receiver is now forced to the back channel, the RD signal is clamped to a Mark, and the $\overline{\text{CD}}$ signal is clamped OFF. The TD input is released and a carrier appears at

the TC output which follows the Mark/Space applied to TD. $\overline{\text{RTS}}$ turning ON initiates a delay, t_{RCON} , at the end of which the $\overline{\text{CTS}}$ output goes Low. When $\overline{\text{CTS}}$ goes Low, data may be transmitted through input TD. Data transmission continues until $\overline{\text{RTS}}$ is turned OFF. At this time several events are initiated. First a delay (t_{RCOFF}) is initiated at the end of which $\overline{\text{CTS}}$ turns OFF. The TD input is ignored as soon as $\overline{\text{RTS}}$ goes OFF. If a 202 mode or V.23 soft turn-off mode is selected, a soft turn-off tone appears at the TC output for a time (t_{STO}) followed by silence (0.0 volts). For both 202 and V.23 modes a squelch period, t_{SQ} , is initiated when $\overline{\text{RTS}}$ goes OFF. During this period the CD output is clamped OFF, forcing the RD output to a Mark condition. The squelch period begins as soon as $\overline{\text{RTS}}$ goes OFF and thus overlaps both t_{RCOFF} and t_{STO} . At the end of the squelch period, the state machine returns to the idle loop at point A in Figure 6.

The reasons for squelch and soft-turnoff are as follows:

Soft Turn-Off—When $\overline{\text{RTS}}$ is turned OFF at the end of a message, transients occur which may cause spurious space signals to be received at a remote modem. During soft turn-off the modem transmits a soft carrier frequency for a period (t_{STO}) after $\overline{\text{RTS}}$ is turned OFF. This results in a steady Mark on the RD line of the remote modem.

Squelch—The local receiver must be turned OFF after $\overline{\text{RTS}}$ is OFF, until the start of carrier detect, so that line transients are not demodulated. The process of disabling the receiver after $\overline{\text{RTS}}$ is turned OFF is called squelching.

Back Channel

This transmission sequence, shown in Figure 7, is entered if a 202 or V.23 mode is selected. $\overline{\text{RTS}}$ is OFF, and $\overline{\text{BRTS}}$ is asserted. The BCD output is forced OFF and the BRD output is clamped to a Mark. The BTD input is released and a carrier appears at the TC output which follows the Mark/Space applied to BTD. Turning on $\overline{\text{BRTS}}$ initiates a delay (t_{BCRON}) at the end of which the $\overline{\text{BRTS}}$ output goes Low. When $\overline{\text{BRTS}}$ goes Low data may be transmitted through input BTD. Data transmission continues until $\overline{\text{BRTS}}$ is turned OFF. The input BTD is immediately ignored and the TC output is silenced (set to 0.0 volts). Following a short delay (t_{BCOFF}) the output $\overline{\text{BCTS}}$ goes OFF. The signals $\overline{\text{BCD}}$ and BRD are released and the state machine returns to idle at point A of Figure 6.

In 202 5-bps back channel mode, BTD should be tied High. Then $\overline{\text{BRTS}}$ controls the ON/OFF keying modulation. When $\overline{\text{BRTS}}$ is Low, 387 Hz appears at the TC output; when $\overline{\text{BRTS}}$ is High, 0 volts appears at TC.

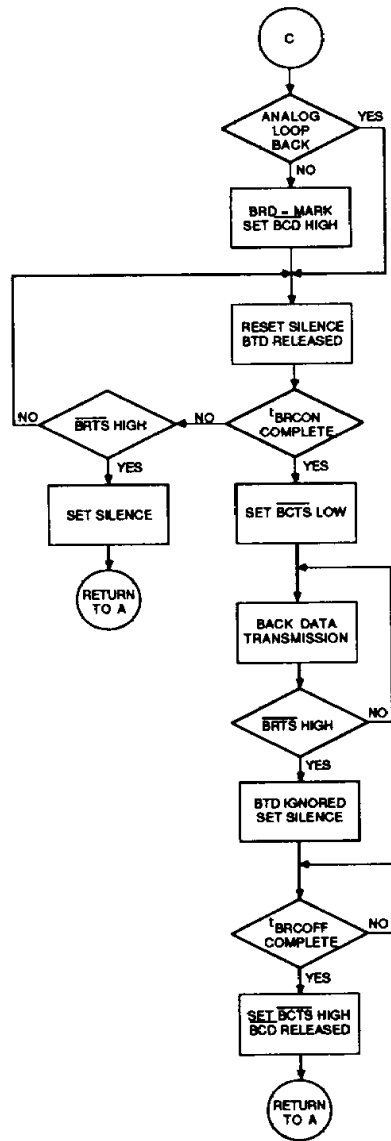

09833A-13

Figure 7. Transmit Back Channel State Diagram

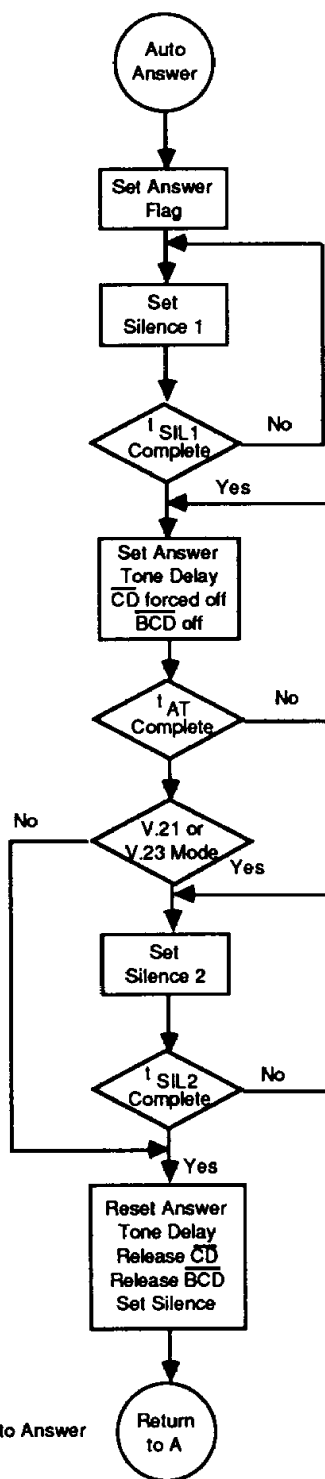

04262-10C

Figure 8. Autoanswer State Diagram

DATA RECEPTION

Data reception is controlled by state machine 2 and depicted in Figure 9. At power on the machine enters initial conditions and remains there until \overline{DTR} is asserted. It then loops until either \overline{CD} or \overline{BCD} occurs.

Full-Duplex

In full-duplex data reception, \overline{CD} may appear at any time after the phone connection has been established. Reception is independent of transmission. When the receiver detects a valid carrier for at least a time (t_{CDON}) the output \overline{CD} is turned ON, the RD output is released, and valid data can be obtained at RD. Data is received until the receiver detects loss of carrier for at least a time (t_{CDOFF}). At this time the \overline{CD} output is turned OFF and RD is clamped to a Mark. The state machine returns to the idle loop at point E.

Half-Duplex

As discussed in the data transmission section above, when a half-duplex mode has been selected the signal

\overline{RTS} controls whether the main channel is transmitting or receiving. The back channel can do only the opposite from the main. If \overline{RTS} is OFF, then \overline{CD} may be activated and the data reception sequence is identical to that discussed above for full-duplex reception. As long as \overline{RTS} remains OFF, \overline{BCD} will never be activated. If \overline{RTS} is ON, then \overline{CD} will never be activated. Instead the receiver will look for a valid carrier in the back channel frequency band. If a valid carrier exists for at least a time (t_{BCDON}) the output \overline{BCD} is turned ON, the BRD output is released and valid data can be obtained at BRD. Data is received until the receiver detects loss of back channel received signal for at least a time (t_{BCDOFF}). At this time the \overline{BCD} output is turned OFF. Data output, BRD, is clamped to a Mark if a V.23 mode or 202 150-bps back channel mode is selected. For 202 5-bps back channel mode, \overline{BCD} represents the received data. The BRD output can be ignored. The state machine returns to the idle loop at point E.

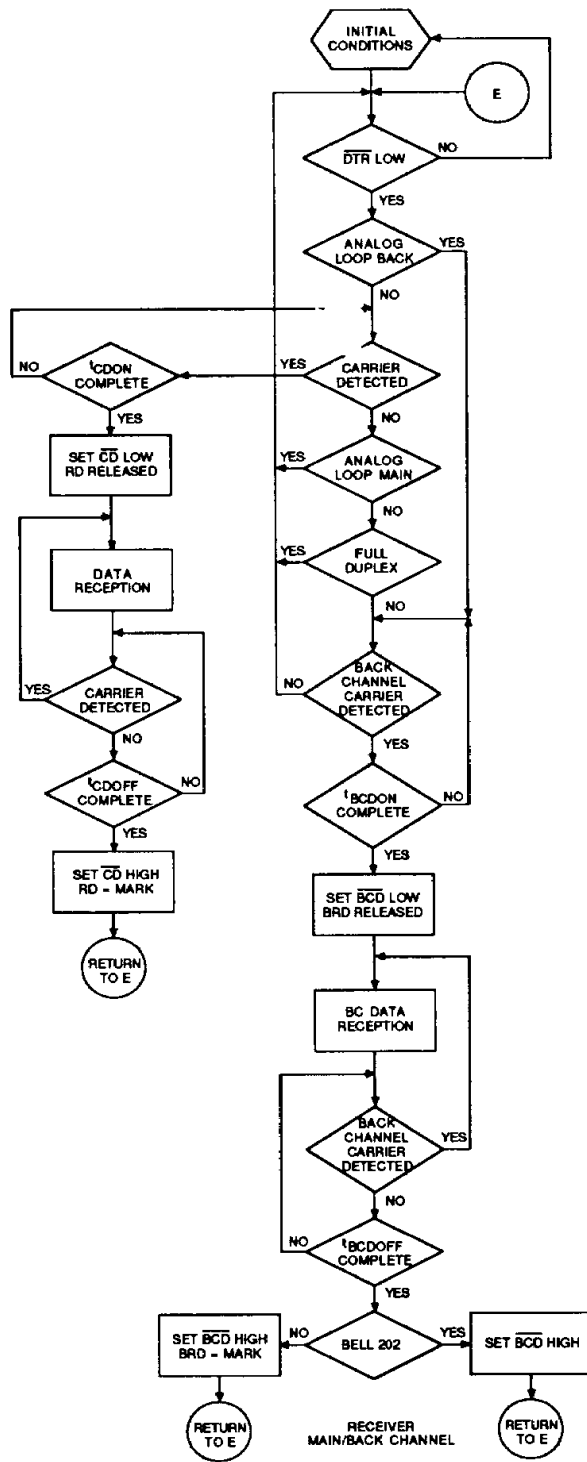

09833A-14

Figure 9. Receiver Main/Back Channel State Diagram

Table 4. Am7910 Timing Parameters
(Refer to Figures 10, 11, 12, and 13 for Timing Diagrams)

Symbol	Description	Bell	Bell	CCITT	CCITT	CCITT	CCITT	CCITT	Bell	Bell	CCITT	CCITT	Units
		103 Orig	103 Ans	V.21 Orig	V.21 Ans	V.23 Mode 1	V.23 Mode 2	V.23 Mode2 EQ	202 202	202 EQ	V.23 Back	202 Back	
t_{RCON} ①	Request-to-Send to Clear-to-Send ON Delay	208.3	208.3	400	400	208.3	208.3	208.3	183.3	183.3	-	-	ms $\pm 0.3\%$
t_{RCOFF} ②	Request-to-Send to Clear-to-Send OFF Delay	0.4	0.4	0.4	0.4	0.4	0.4	0.4	0.4	0.4	-	-	ms $\pm 40\%$
t_{BRCON} ⑦	Back Channel Request-to-Send to Clear-to-Send ON Delay	-	-	-	-	-	-	-	-	-	82.3	-	+0.64%
t_{BRCOFF} ⑧	Back Channel Request-to-Send to Clear-to-Send OFF Delay	-	-	-	-	-	-	-	-	-	0.4	-	ms $\pm 40\%$
t_{CDON} ③	Carrier Detect ON Delay	92.106	92.106	301- 308	301- 308	11.4- 15.4	11.4- 15.4	11.4- 15.4	18- 22	18- 22	-	-	ms
t_{CDOFF} ④	Carrier Detect OFF Delay	21-31	21-31	21-31	21-31	3.5-9	3.5-9	3.5-9	12-17	12-17	-	-	ms
t_{BCDON} ⑨	Back Channel Carrier Detect ON Delay	-	-	-	-	-	-	-	-	-	17- 25	17- 25	ms
t_{BCDOFF} ⑩	Back Channel Carrier Detect OFF Delay	-	-	-	-	-	-	-	-	-	21- 35	21- 35	ms
t_{AT}	Answer Tone Duration	-	1.9	-	3.0	3.0	3.0	3.0	1.9	1.9	-	-	sec $\pm 0.44\%$
t_{SIL}	Silence Interval before Transmission	1.3	1.3	1.9	1.9	1.9	1.9	1.9	1.3	1.3	-	-	sec $\pm 0.64\%$
t_{SQ} ⑪	Receiver Squelch Duration	-	-	-	-	156.3	156.3	156.3	156.3	156.3	-	-	ms $\pm 3.3\%$
t_{STO} ⑫	Transmitter Soft Turn-Off Duration	-	-	-	-	-	-	-	24	24	-	-	ms $\pm 2.3\%$
t_{RING}	Minimum RING Low Duration	-	25	-	25	25	25	25	25	25	-	-	μs

Note: ①-⑫ refer to designations on timing diagrams in Figures 10, 11, 12, and 13.

Table 5. Am7911 Timing Parameters
(Refer to Figures 10, 11, 12, and 13 for Timing Diagrams)

Symbol	Description	Bell 103 Orig	Bell 103 Ans	CCITT V.21 Orig	CCITT V.21 Ans	CCITT V.23 Mode 1	CCITT V.23 Mode 2	CCITT V.23 Mode 2 EQ	Bell 202	Bell 202 EQ	CCITT V.23 Back	Bell 202 150 Back	Bell 202 5 Back	Units
t _{RCON} ①	Request-to-Send to Clear-to-Send ON Delay	25.0	25.0	25.0	25.0	8.0	8.0	8.0	8.0	8.0	—	—	—	ms ±0.3%
t _{RCOFF} ⑦	Request-to-Send to Clear-to-Send OFF Delay	0.52	0.52	0.52	0.52	0.52	0.52	0.52	0.52	0.52	—	—	—	ms ±40%
t _{BRCON} ⑧	Back Channel Request-to-Send to Clear-to-Send ON Delay	—	—	—	—	—	—	—	—	—	82.3	82.3	—	ms ±0.64%
t _{BRCOFF} ⑩	Back Channel Clear-to-Send OFF Delay	—	—	—	—	—	—	—	—	—	0.52	0.52	—	ms ±40%
t _{CDON} ③	Carrier Detect ON Delay	10–16	10–16	10–16	10–16	3–5	3–5	3–5	3–5	3–5	—	—	—	ms
t _{CDOFF} ④	Carrier Detect OFF Delay	7–20	7–20	7–20	7–20	2–8.5	2–8.5	2–8.5	2–8.5	2–8.5	—	—	—	ms
t _{BCDON} ⑨	Back Channel Carrier Detect ON Delay	—	—	—	—	—	—	—	—	—	18–20	18–20	3–6	ms
t _{BCDOFF} ⑩	Back Channel Carrier Detect OFF Delay	—	—	—	—	—	—	—	—	—	22–35	22–35	8–20	ms
t _{AT}	Answer Tone Duration	—	1.9	—	3.0	3.0	3.0	3.0	1.9	1.9	—	—	—	sec ±0.44%
t _{SIL1}	Silence Interval before Transmission	—	2.0	—	2.0	2.0	2.0	2.0	2.0	2.0	—	—	—	sec ±0.64%
t _{SIL2}	Silence after AT	—	—	—	75	75	75	75	75	75	—	—	—	sec ±0.69%
t _{SO} ⑪	Receiver Squelch Duration	—	—	—	—	9.0	9.0	9.0	9.0	9.0	—	—	—	ms ±3.3%
t _{STO} ⑫	Transmitter Soft Turn-Off Duration	—	—	—	—	8.0*	8.0*	8.0*	8.0	8.0	—	—	—	ms ±2.3%
t _{RING}	Minimum RING Low Duration	—	25	—	25	25	25	25	25	25	—	—	—	μs

* Soft turn-off tone is generated only for selected V.23 modes.

Note: ①–⑫ refer to designations on timing diagrams in Figures 10, 11, 12, and 13.

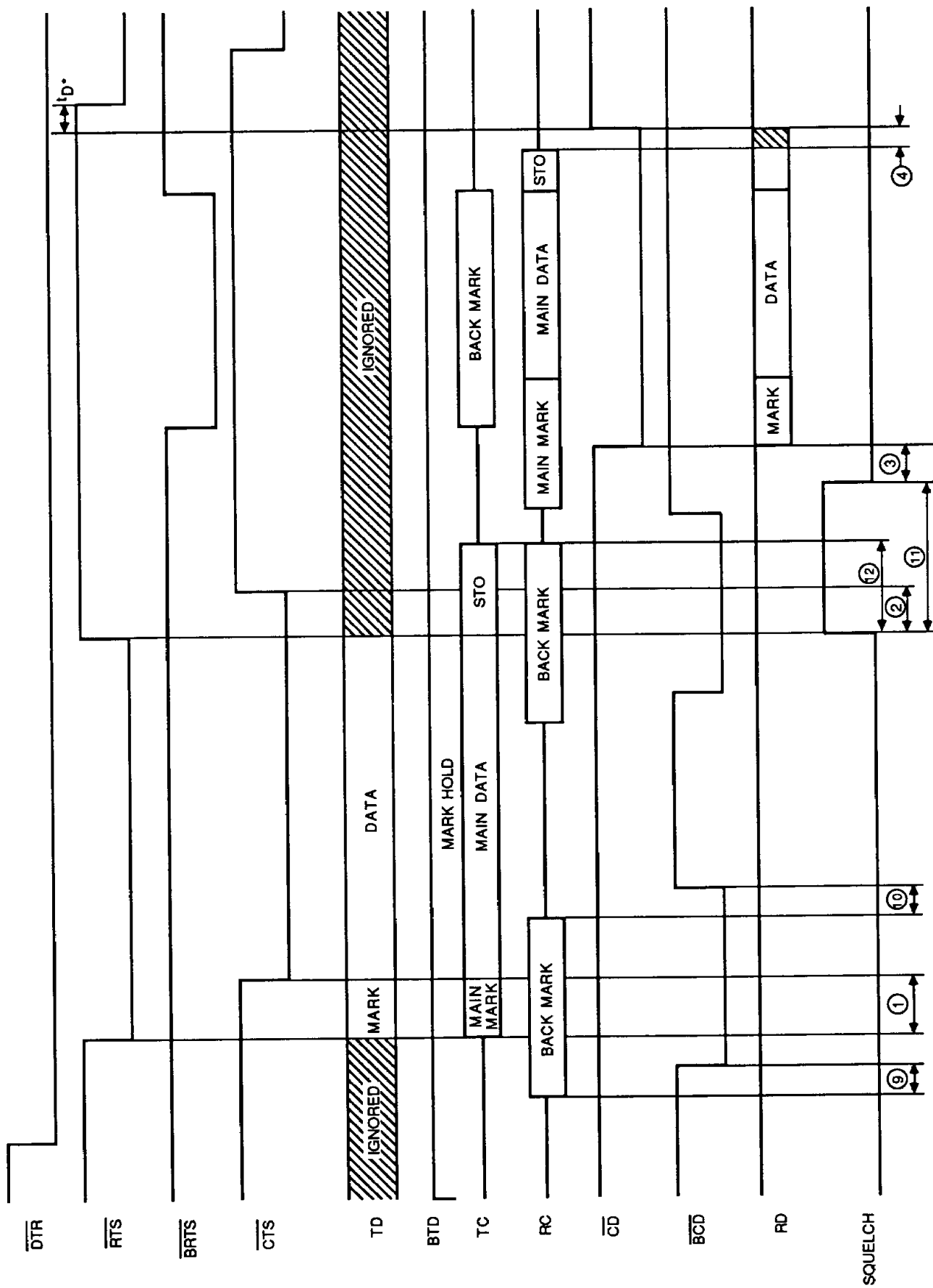

08633A-15

Figure 10. Bell 202 Handshake Timing with 5-bps Back Channel**

* t_D is an external delay provided by the user; $t_D > 0$.
 ***This timing diagram is not to scale. See Tables 4 and 5 for values.

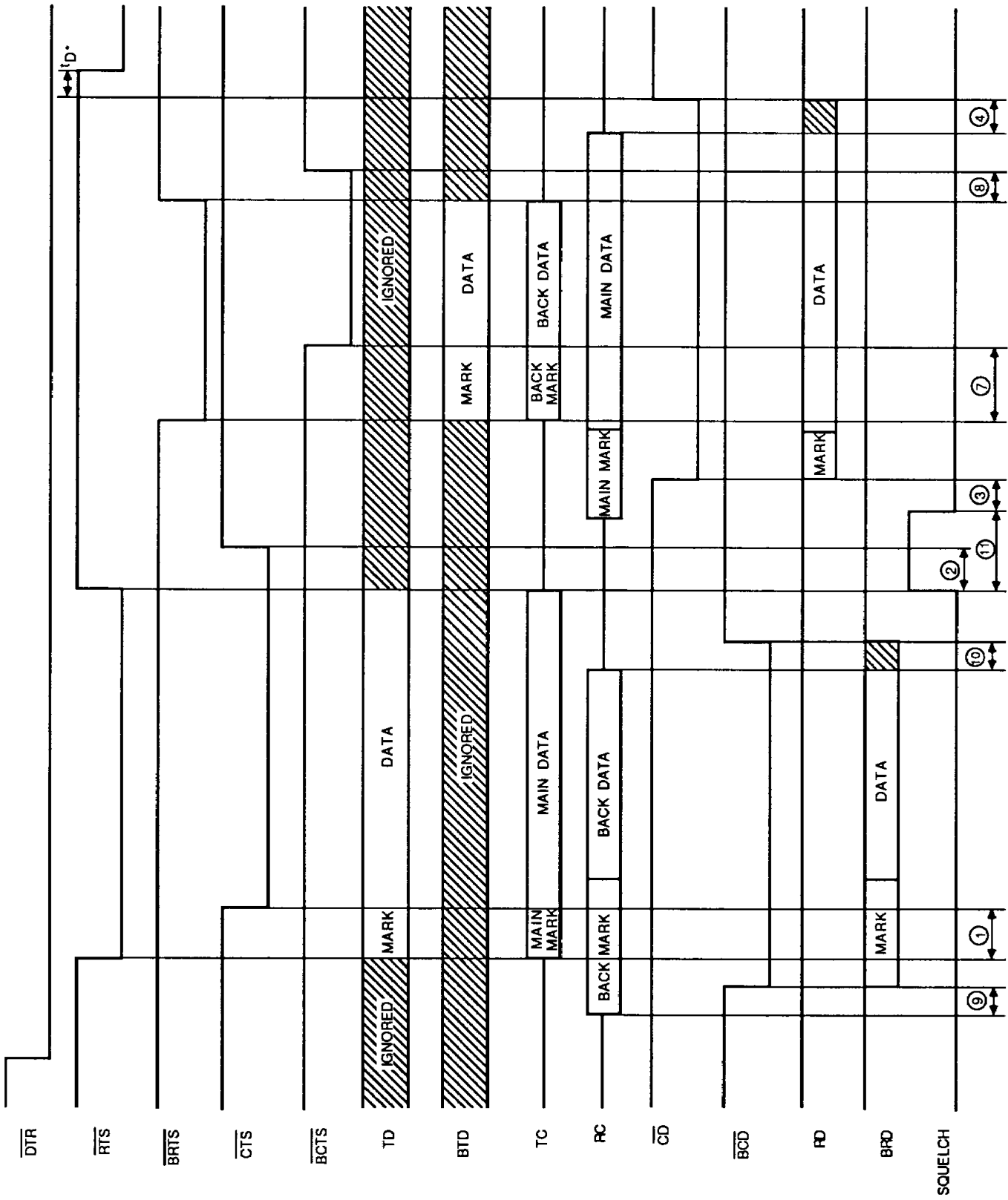

Figure 11. CCITT V.23 Handshake Timing**

* t_D is an external delay provided by the user; t_D > 5 msec.

**This timing diagram is not to scale. See Tables 4 and 5 for values.

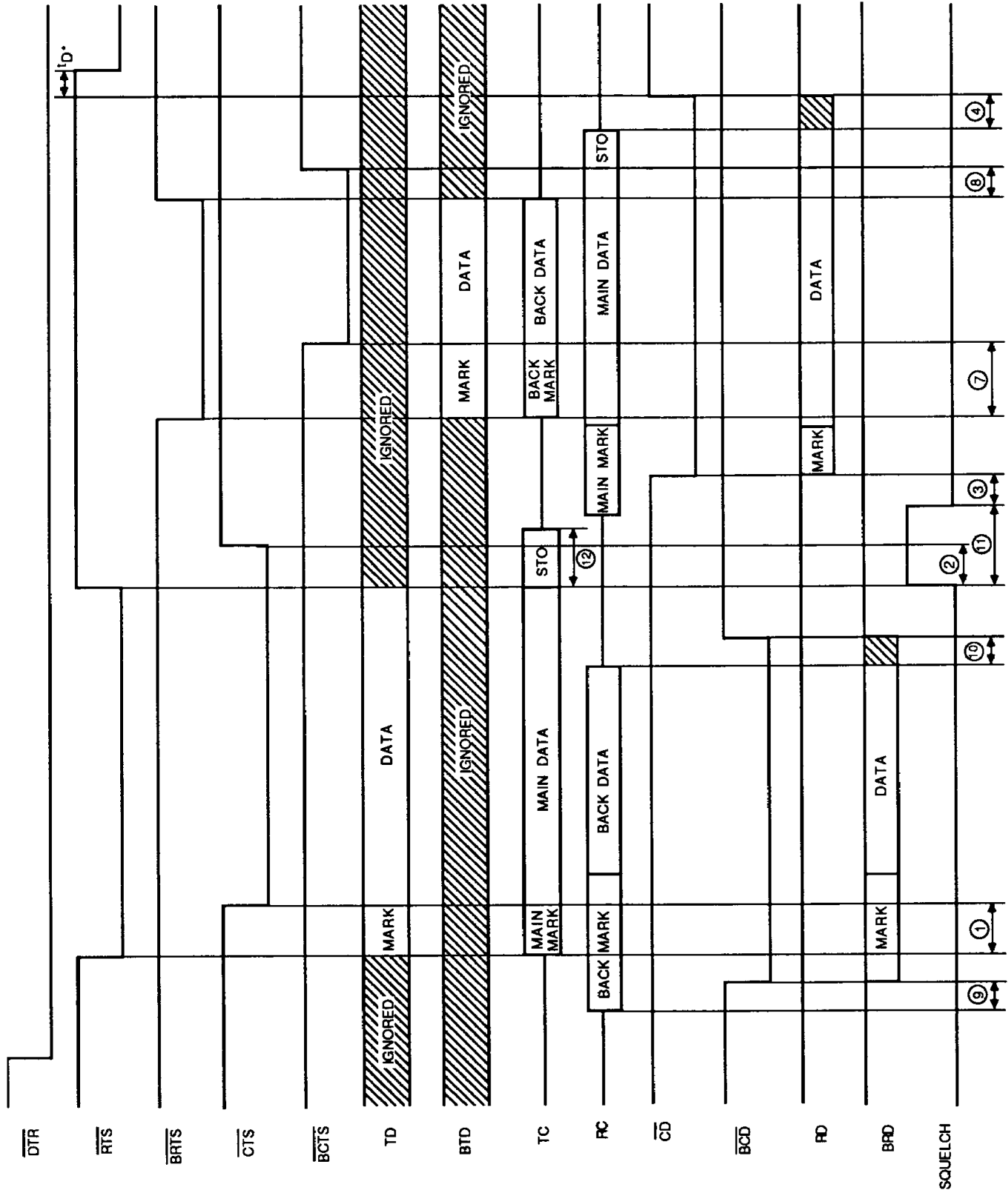
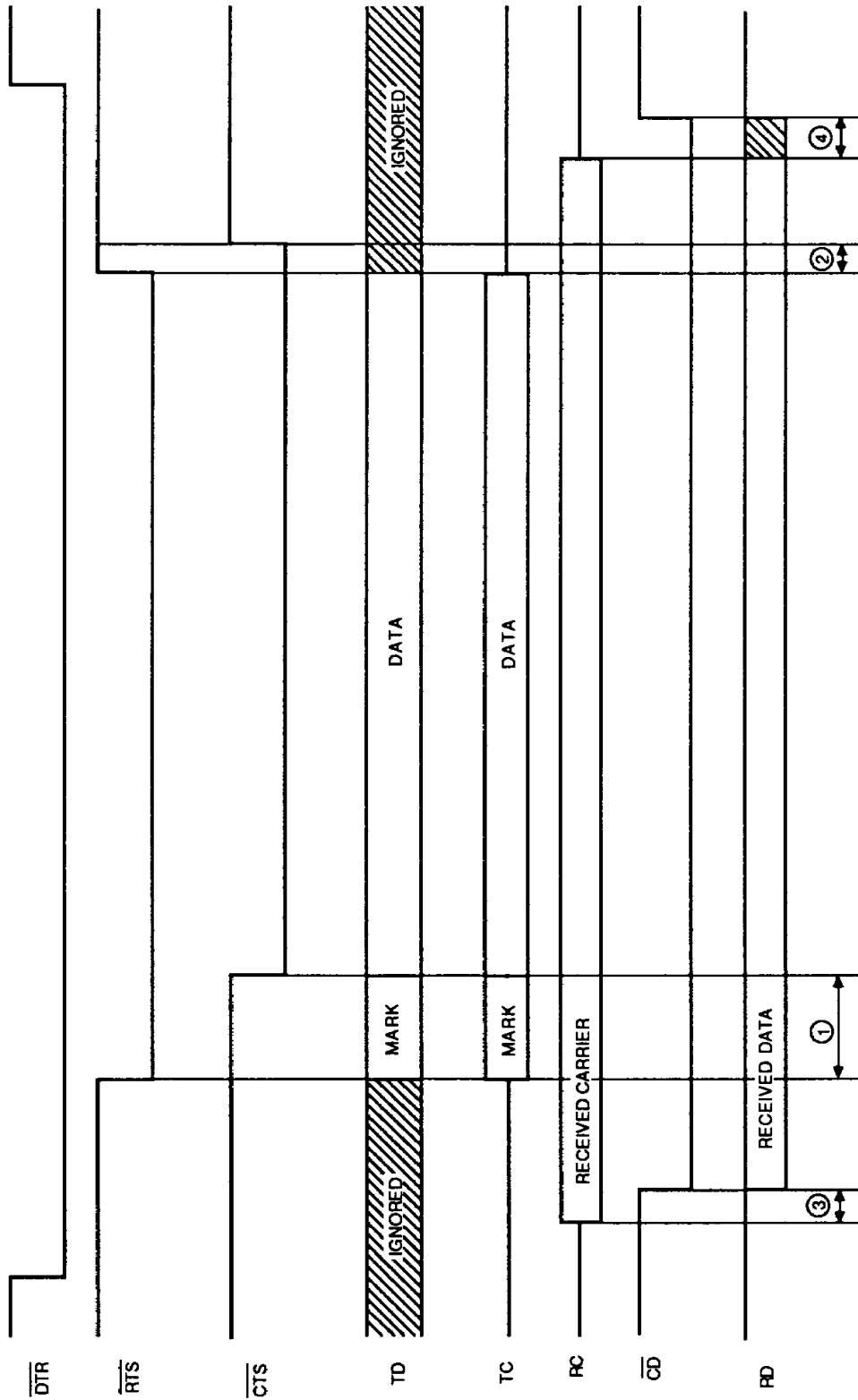

Figure 12. V.23 STO and Bell 202, 150 bps Handshake Timing**

* tD is an external delay provided by the user; tD > 0.

**This timing diagram is not to scale. See Tables 4 and 5 for values.



09833A-18

*This timing diagram is not to scale. See Tables 4 and 5 for values.

Figure 13. Bell 103/V.21 Handshake Timing*

LOOPBACK

Eleven modes exist to allow both analog and digital loopback for each modem specification met by the Am7911 (ten modes for the Am7910). When a loopback mode is selected, the signal processing (filters, etc.) for both the transmitter and receiver is set to process the same channel or frequency band. This allows the analog output (TC) and the analog input (RC) to be connected for local analog loopback. Alternatively the digital data signals (TD and RD or BTD and BRD) can be connected externally, allowing a remote modem to test the local modem with its digital data signals looped back.

When a loopback mode is selected, the state machine sequences are altered slightly. First, autoanswer is disabled. Second, if a half-duplex loopback mode is selected (202 or V.23), the local $\overline{CD/BCD}$ is not forced OFF when $\overline{RTS/BRTS}$ is asserted.

The 202 and V.23 main loopback modes allow use in a four-wire configuration at 1200 bps.

Four-Wire, Full-Duplex

The modem can be configured to work full-duplex over four-wires by selecting one of the loopback modes. The loopback modes allow independent operation of the transmitter and the receiver within the modem.

The 202 and V.23 main loopback modes allow full-duplex communication of up to 1200 bps over four-wires.

CLOCK GENERATION

Master timing of the modem is provided by either a crystal connected to the XTAL₁ and XTAL₂ pins or an external clock applied to XTAL₁.

Crystal

When a crystal is used it should be connected as shown in Figure 14. The crystal should be a parallel resonance type, and its value must be 2.4576 MHz \pm .01%. A list of crystal suppliers is shown below.

External Clock

This clock signal could be derived from one of several crystal-driven baud rate generators. It should be connected to XTAL₁ and XTAL₂ must be left floating. The timing parameters required of this clock are shown in Figure 15 and the values are listed in Table 6.

Crystal Information (f = 2.4576 MHz)

Manufacturer	P/N	C1	C2
M-Tron	MP-2	10 pF	20 pF
Monitor Products	MM-33	10 pF	20 pF

Note: Rise time of V_{CC} must be greater than 5 ms to ensure proper crystal oscillator start-up.

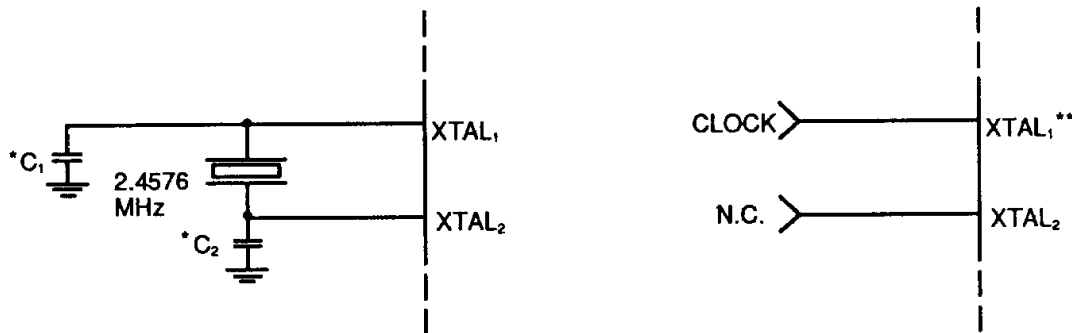

* Capacitor values vary with different crystal manufacturers.

** The input impedance of this pin appears as 5 to 10 pF to ground in parallel with at least 1 Megohm.

Figure 14. Clock Generation

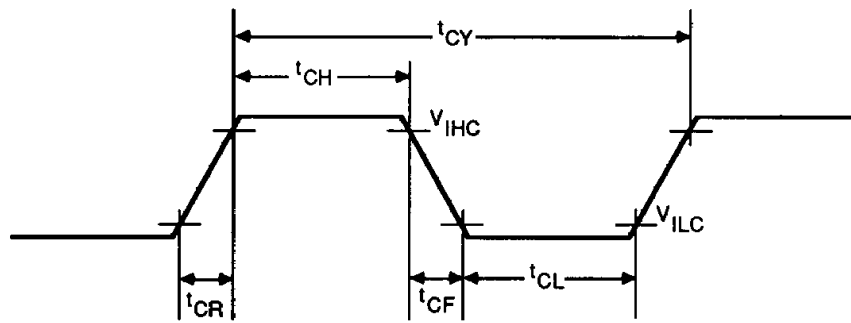

Figure 15. External Clock

Table 6. Clock Parameters

Symbol	Parameters	Min.	Typ.	Max.	Units
t_{CV}	Clock Period	406.86	406.9	406.94	ns
t_{CH}	Clock High Time	165			ns
t_{CL}	Clock Low Time	165			ns
t_{CR}	Clock Rise Time			20	ns
t_{CF}	Clock Fall Time			20	ns

Reset Modes

Automatic Power-On-Reset in Figure 16 is the recommended circuit to initiate the internal reset sequence automatically whenever V_{CC} is applied. V_{CC} rise time should be faster than one half the RC time constant. The modem contains a diode to discharge the capacitor when $V_{CC} = 0$ V.

Reset Input—The modem can be forced into the internal reset sequence by setting $\overline{\text{RESET}}$ Low for at least one clock period.

Note that V_{CC} must be at least +3.5 V for proper reset operation. Between repetitive reset pulses, $\overline{\text{RESET}}$ must be High for at least 1 μs , as shown in Figure 17.

Upon device initialization or mode change, $\overline{\text{DTR}}$ must be brought High for a time $t_{MSU} > 100$ ms, as shown in Figure 18.

Power Supply

For maximum performance, power supply bypassing should be used. V_{CC} should be decoupled to DGND and V_{BB} to AGND as shown in Figure 19. The 0.01 μF ceramic disc capacitors should be mounted as physically close to the pins as possible.

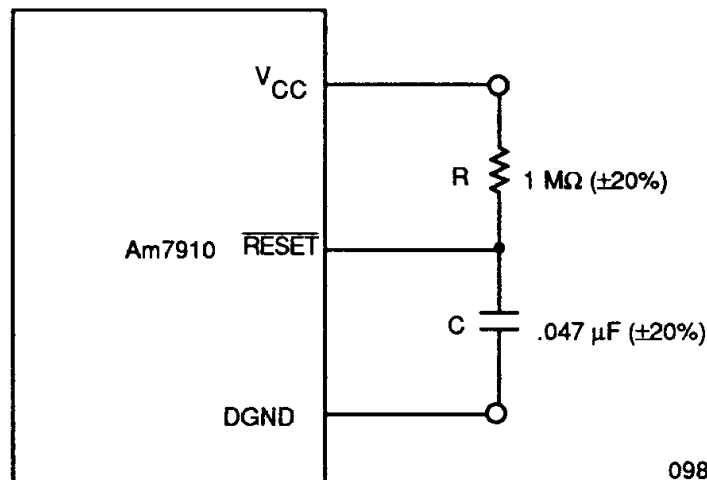
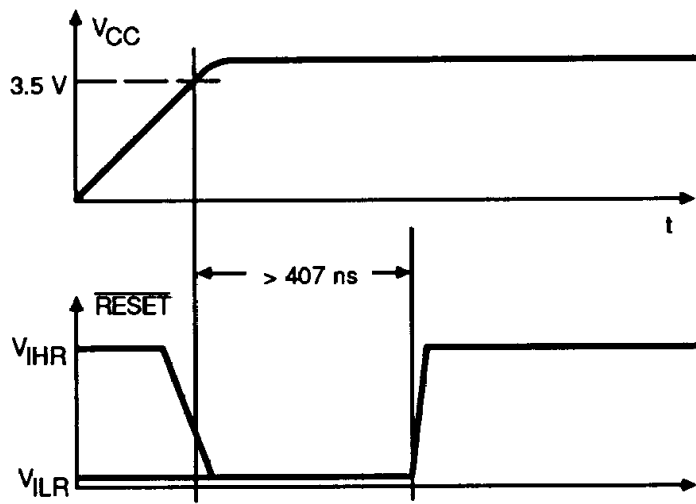
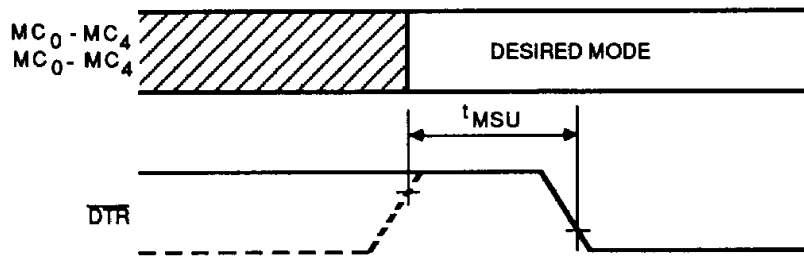

Figure 16. Automatic Reset



09833A-21

Figure 17. Reset Timing Diagrams



09833A-22

Figure 18. Mode Setup

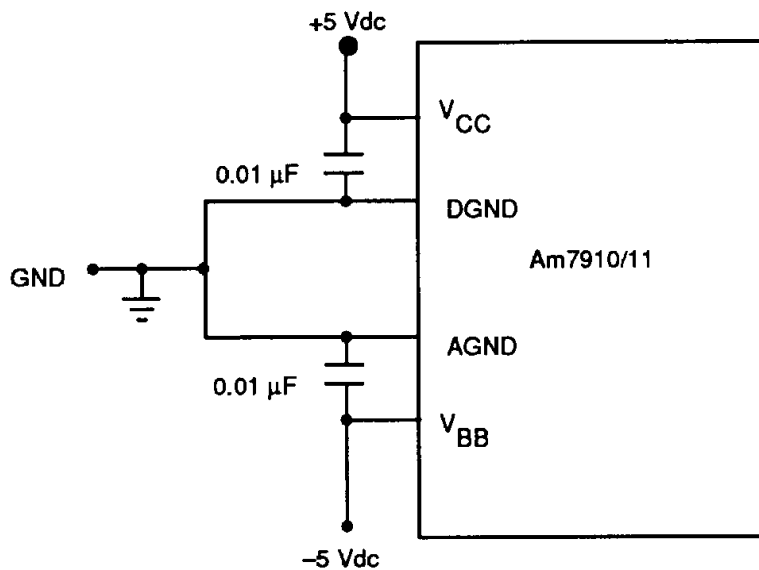

09833A-31

Figure 19. Power-Supply Connections

ABSOLUTE MAXIMUM RATINGS

Storage Temperature	-65 to +125°C
Ambient Temperature with Power Applied	
Commercial (C) Devices	0 to +70°C
Industrial (I) Devices	-40 to +85°C
Extended (E) Devices	-55 to +125°C
V_{CC} with Respect to DGND	+6 V / -4 V
V_{BB} with Respect to DGND	-6 V / +4 V
All Signal Voltages with Respect to DGND	+5 V

Stresses above those listed under ABSOLUTE MAXIMUM RATINGS may cause permanent device failure. Functionality at or above these limits is not implied. Exposure to absolute maximum ratings for extended periods may affect device reliability.

OPERATING RANGES

Positive Supply Voltage (V_{CC})	+4.75 to +5.25 V
Negative Supply Voltage (V_{BB})	-4.75 to -5.25 V
Commercial (C) Devices	0 to +70°C
Industrial (I) Devices	-40 to +85°C
Extended (E) Devices	-55 to +125°C

Operating ranges define those limits between which the functionality of the device is guaranteed.

DC CHARACTERISTICS (over operating ranges unless otherwise specified)

Digital Inputs: MC0–MC4, $\overline{\text{DTR}}$, $\overline{\text{BRTS}}$, TD, BTD, $\overline{\text{RTS}}$, RING

Digital Outputs: CTS, $\overline{\text{BCTS}}$, $\overline{\text{CD}}$, $\overline{\text{BCD}}$, RD, BRD

Parameter Symbol	Parameter Descriptions	Test Conditions	Min.	Typ.	Max.	Unit
V_{OH}	Output High Voltage	$I_{OH} = -400 \text{ mA}$ $C_{LD} = 50 \text{ pF}$	2.4			V
V_{OL}	Output Low Voltage	$I_{OL} = 2 \text{ mA}$ $C_{LD} = 50 \text{ pF}$ C,I Devices E Devices			0.4 0.6	V V
V_{IH}	Input High Voltage		2.0		V_{CC}	V
V_{IL}	Input Low Voltage		-0.5		0.8	V
V_{IHC}	External Clock Input High (XTAL ₁)		3.8		V_{CC}	V
V_{ILC}	External Clock Input Low (XTAL ₁)		-0.5		0.8	V
V_{IHR}	External Reset Input High ($\overline{\text{Reset}}$)		3.8		V_{CC}	V
V_{ILR}	External Reset Input Low ($\overline{\text{Reset}}$)		-0.5		0.8	V
I_{IL}	Digital Input Leakage Current	$0.0 < V_{IN} < V_{CC}$	-10		10	μA
I_{ILR}	Reset Input Leakage Current	$0.0 < V_{IN} < V_{CC}$ C,I Devices E Devices	-0.75 -1.0		0.75 1.0	μA μA
I_{CC}	V_{CC} Supply Current	C Devices I Devices E Devices			140 160 170	mA mA mA
I_{BB}	V_{BB} Supply Current	C Devices I Devices E Devices			15 20 25	mA mA mA
C_{OUT}	Output Capacitance	$f = 1.0 \text{ MHz}$			15	pF
C_{IN}	Input Capacitance	$f = 1.0 \text{ MHz}$			15	pF
V_{CC}	Positive Supply Voltage		4.75		5.25	V
V_{BB}	Negative Supply Voltage		-4.75		-5.25	V
AGND, DGND	Ground Offset		-50		50	mV

Standard Load Circuit

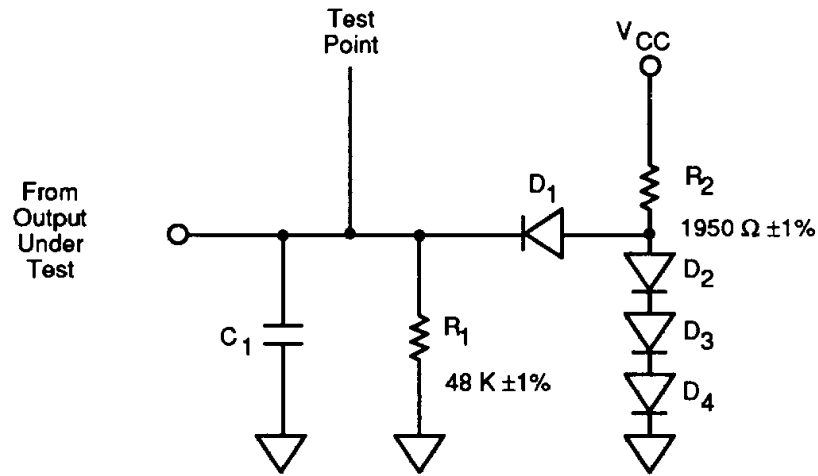

09833A-24

- Notes:
1. $C_1 = 50$ pF including stray and wiring capacitance
 2. All diodes are 1N3064 or equivalent
 3. All resistors are 1/8 watt
 4. $V_{CC} = 5$ Volts \pm 5%

SWITCHING CHARACTERISTICS over operating ranges

Parameter Symbol	Parameter Descriptions	Min.	Typical	Max.	Unit	Part
Transmitter						
V_{TC}	TC Output Voltage		0.548 -3.0		V_{RMS} dBm	
V_{TCOS}	TC DC Offset	-100		100	mV	
T_{DEL}	Delay from TD to TC Change			8.3	μs	
f_{ACC}	Frequency Accuracy (Except 202)	-0.4		0.4	Hz	
f_{ACC}	Frequency Accuracy 202 Mark	-1.0		1.0	Hz	
Receiver						
V_{RC}	RC Input Voltage	-1.6		1.6	V	
R_{IN}	Input Resistance	50			Kohms	
V_{RCOS}	Allowed DC Input Offset	-30		+30	mV	
f_{TOL}	Frequency Deviation Tolerance	-16		16	Hz	
V_{CDON}	Carrier Detect on Level		-40.5*		dBm	7910
			-42.0*		dBm	7911
V_{CDOFF}	Carrier Detect off Level		-45.0*		dBm	7910
			-47.5*		dBm	7911
V_{HYS}	Carrier Detect Hysteresis		4.5*		dB	7910
			5.5*		dB	7911

Note: All TC levels are measured using a 600 ohm load.
 All dBm measurements are referenced to 600 ohm.
 * nominal spread = ± 1 dB

Out-of-Band energy: See Figure 16

Performance

Figure 20 shows a graph of nominal bit error rates for the various modem types. A flat line condition, back-to-back wire connection, is used to allow easy correlation by users.

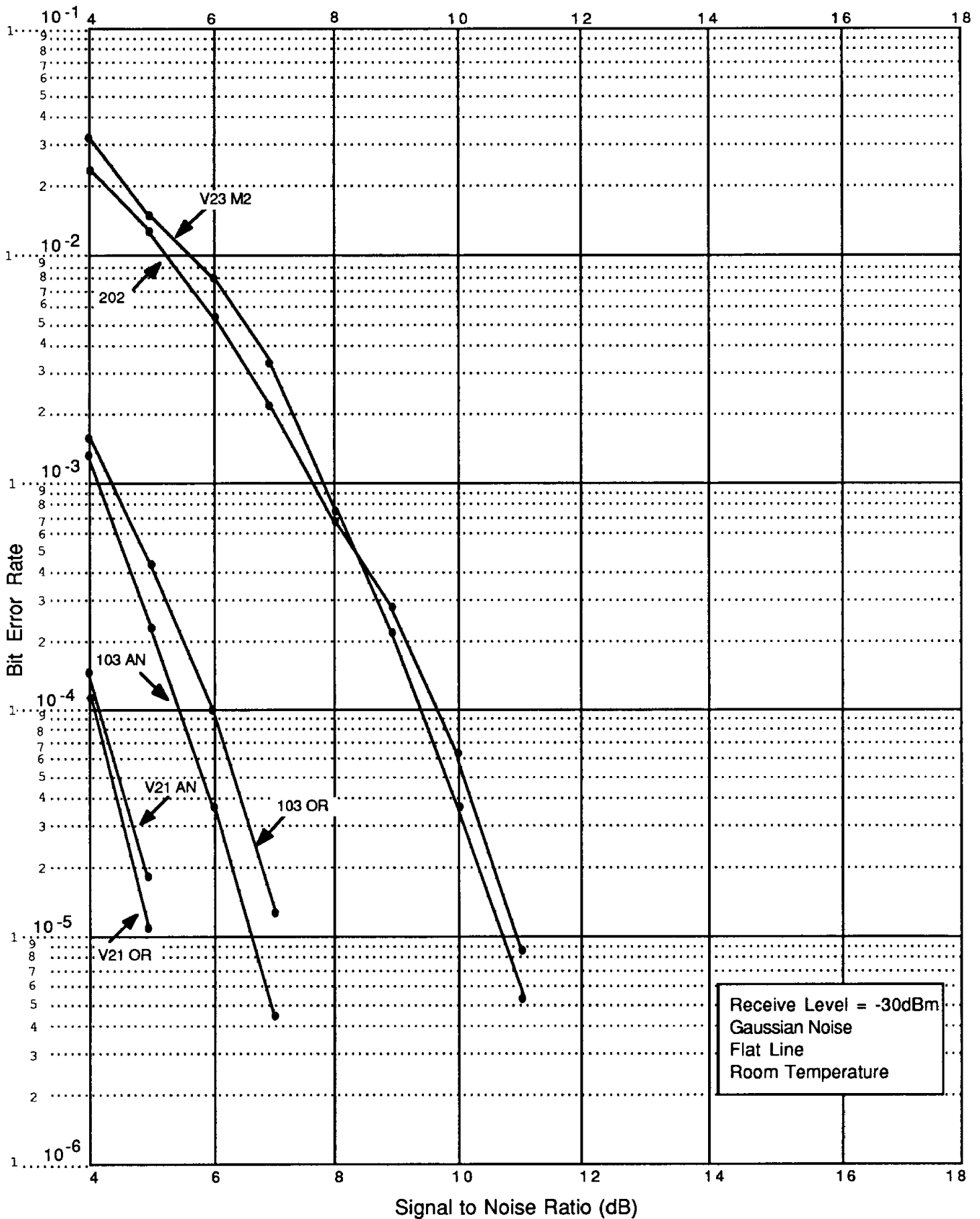

Figure 20. Am7910/11 Nominal Bit Error Rate

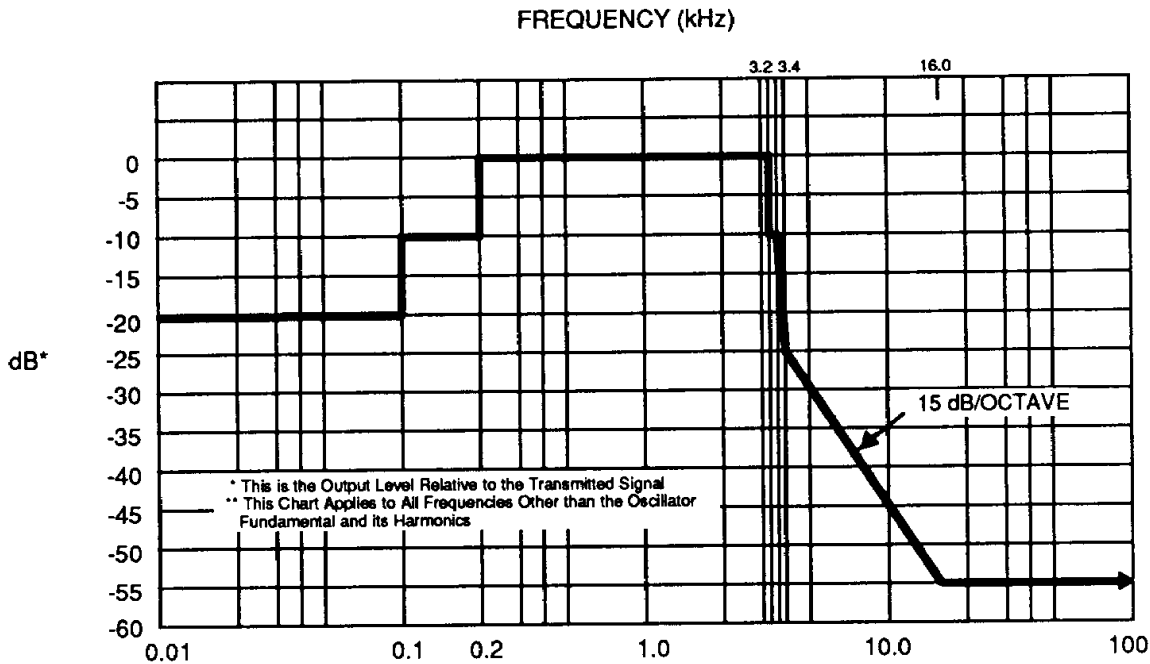

Figure 21. Out-of-Band Transmitter Energy

APPLICATIONS

The Am7910 and Am7911 allow designs for many FSK applications. The AMD Modem Technical Manual goes into details on many different applications with specific examples. The Modem Technical Manual also gives additional information on the hybrid (Figure 19) and line interface design (Figure 20) (Order No. 09560C).

Stand-Alone Modem

A stand-alone modem can be configured using the Am7910/11 RS-232/V.24 line drivers and receiver, a phone line interface (DAA or acoustic coupler), and a two-to-four wire hybrid. A modem suitable for connection to a serial computer port is shown in Figure 17. Since the Am7910/11 interfaces only to TTL-level devices, RS-232/V.24 line drivers and receivers are required for connection to devices accepting standard RS-232/V.24 voltage levels.

Automatic answering of the telephone can be assisted by the Am7910/11 in this arrangement. Once the DAA has been placed in the off-hook state by the user's interface, the DAA will assert **RING** on the Am7910/11. This answer tone conforms to the Bell and CCITT V.25 standards on duration, frequency, and amplitude. Tying **RING** High on the Am7910/11 disables the generation of the answer tone.

System Configurations

Since the Am7910 and Am7911 are multi-mode modems, one basic modem design can be used to meet both North American and International market requirements. Under the control of a microcontroller such as the Am8031/51, the modems can be easily reconfigured from one mode to another with no hardware changes. Both modems are autoanswer, but to implement autodial an external DTMF generator is required. A sister chip, the Am79101 includes full autodial support with integral DTMF generation, Call Progress Tone Detection, and Answer Tone Detection. The four-to-two-wire hybrid function is also on-chip.

In contrast to the standard two-wire dial-up or switched network, most dedicated networks use four-wire leased lines. The Am7910 and Am7911 can be easily configured for four-wire full-duplex operation at 1200 bps. The Am7911 is the recommended modem for this application due to the short RTS/CTS delay timing which allows multidrop operation on four-wires. Figure 18 shows an example of the Am7910/7911 under the control of an Am8051; the modem is placed in analog loopback to allow 1200 bps full-duplex operation. The line interface typically comprises two line isolation transformers with a simple line impedance matching network and appropriate protective diodes.

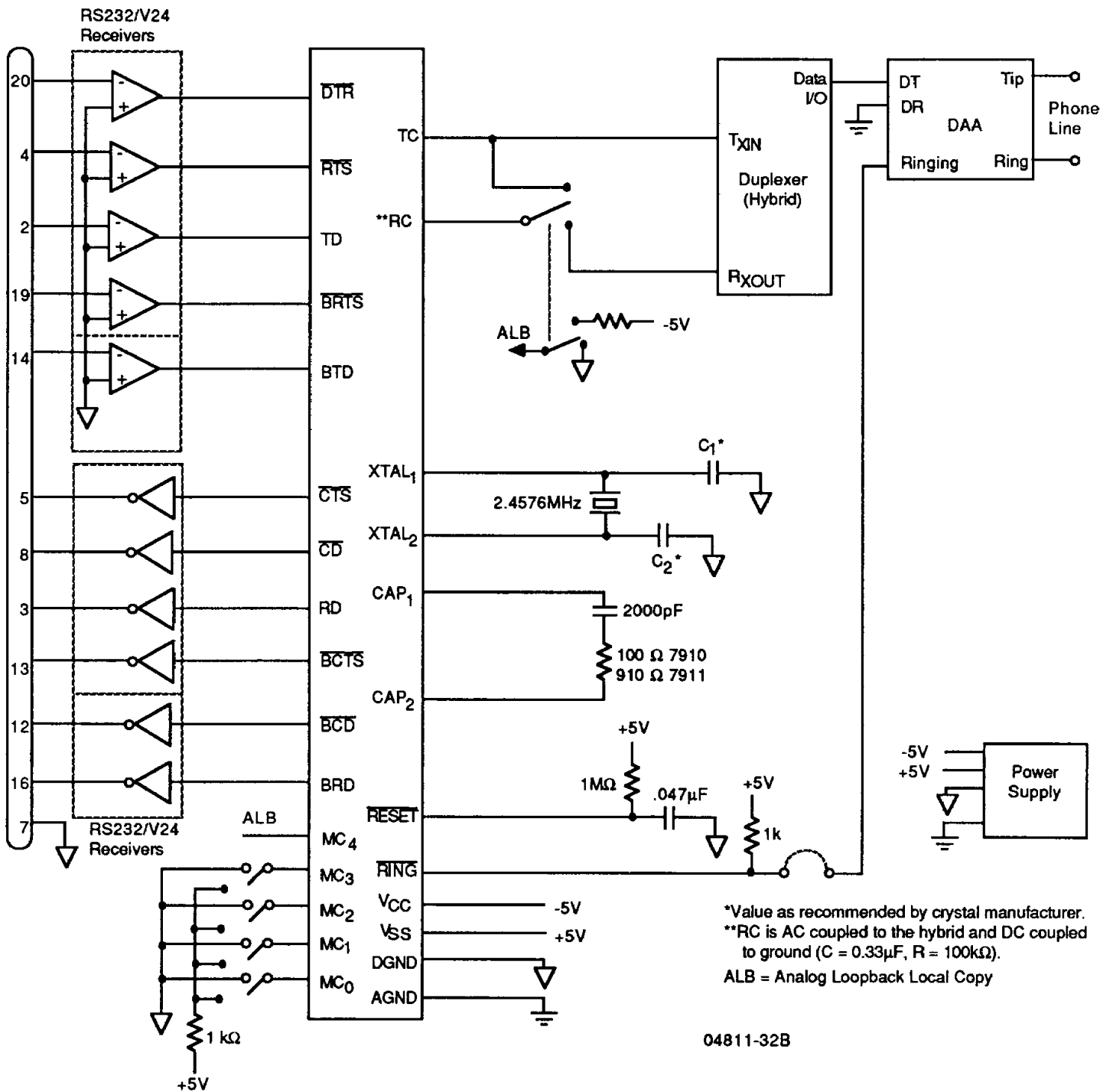
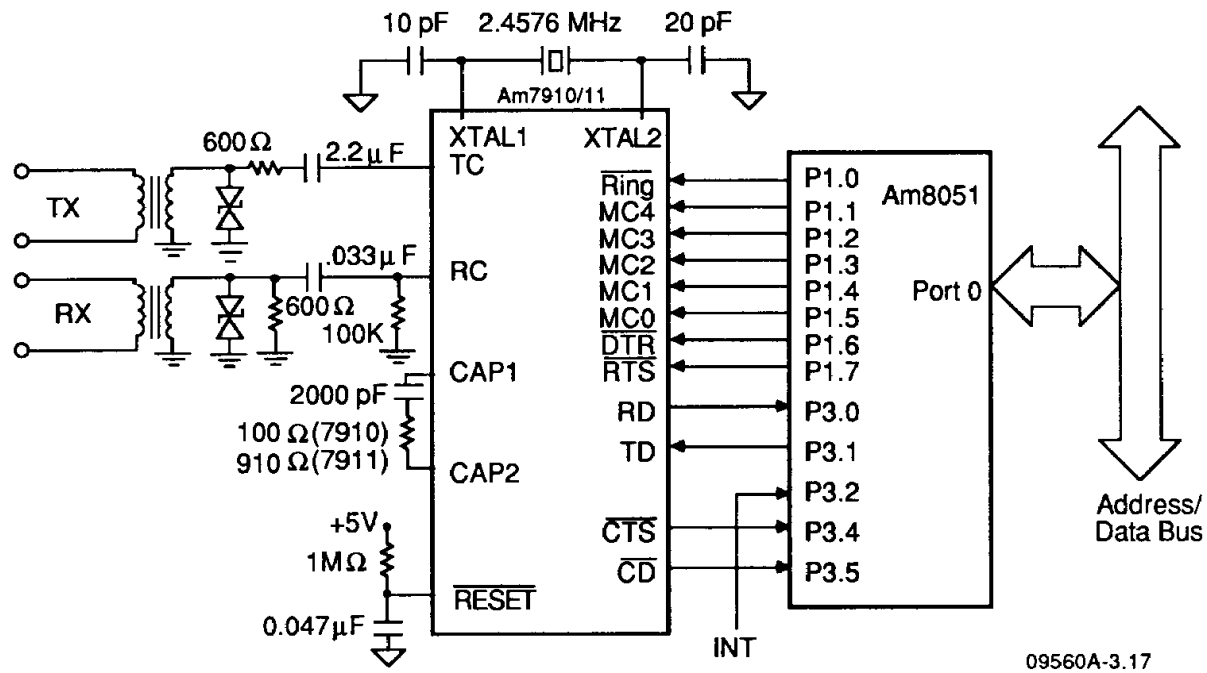
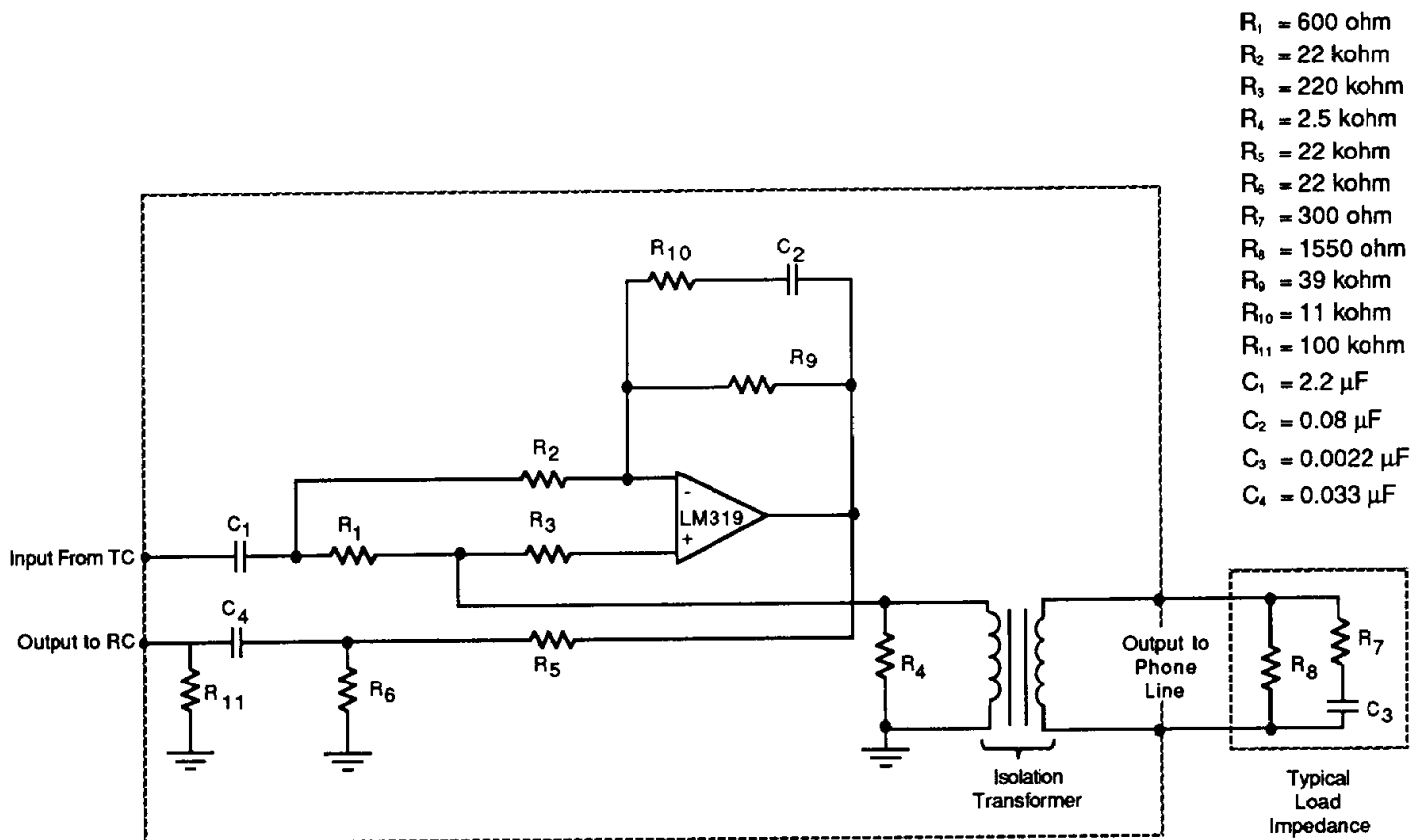

Figure 22. Stand-Alone 7910/11 Application



09560A-3.17

Figure 23. 1200 bps Four-Wire Full-Duplex Circuit



04811-30B

Figure 24. Four-to-Two Wire Active Hybrid Circuit

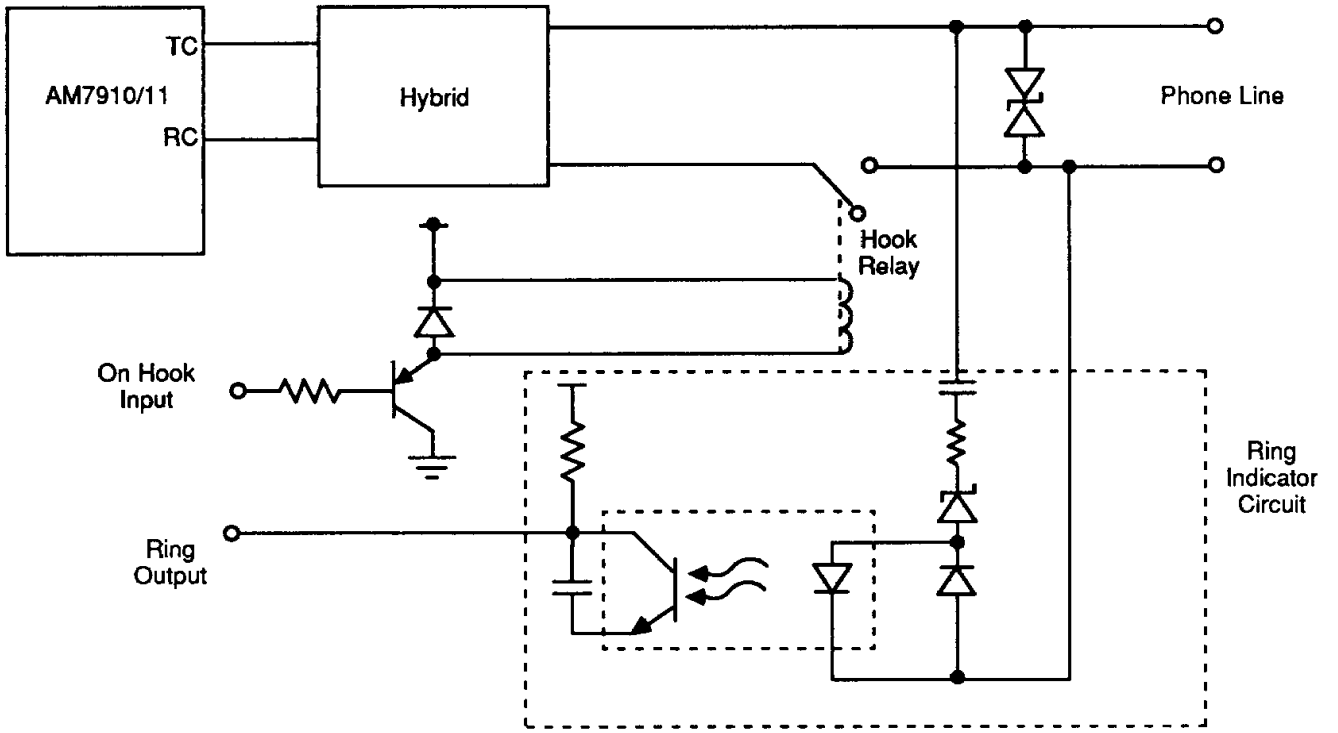

09560B-6.2

Figure 25. Am 7910/11 Phone Line Circuit

PHYSICAL DIMENSIONS

PD 028

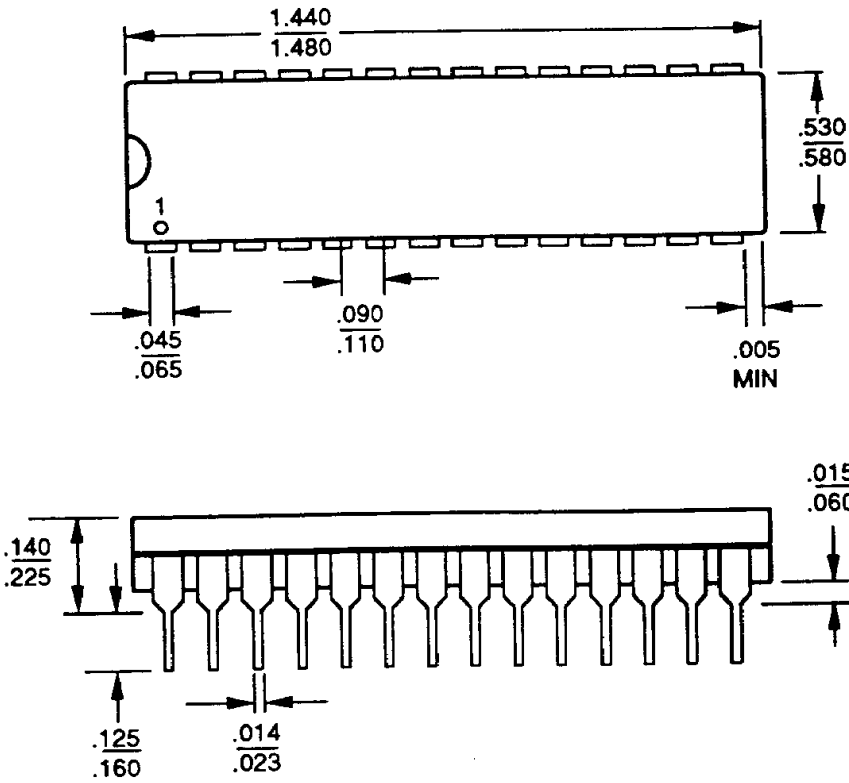

06842B

CD 028

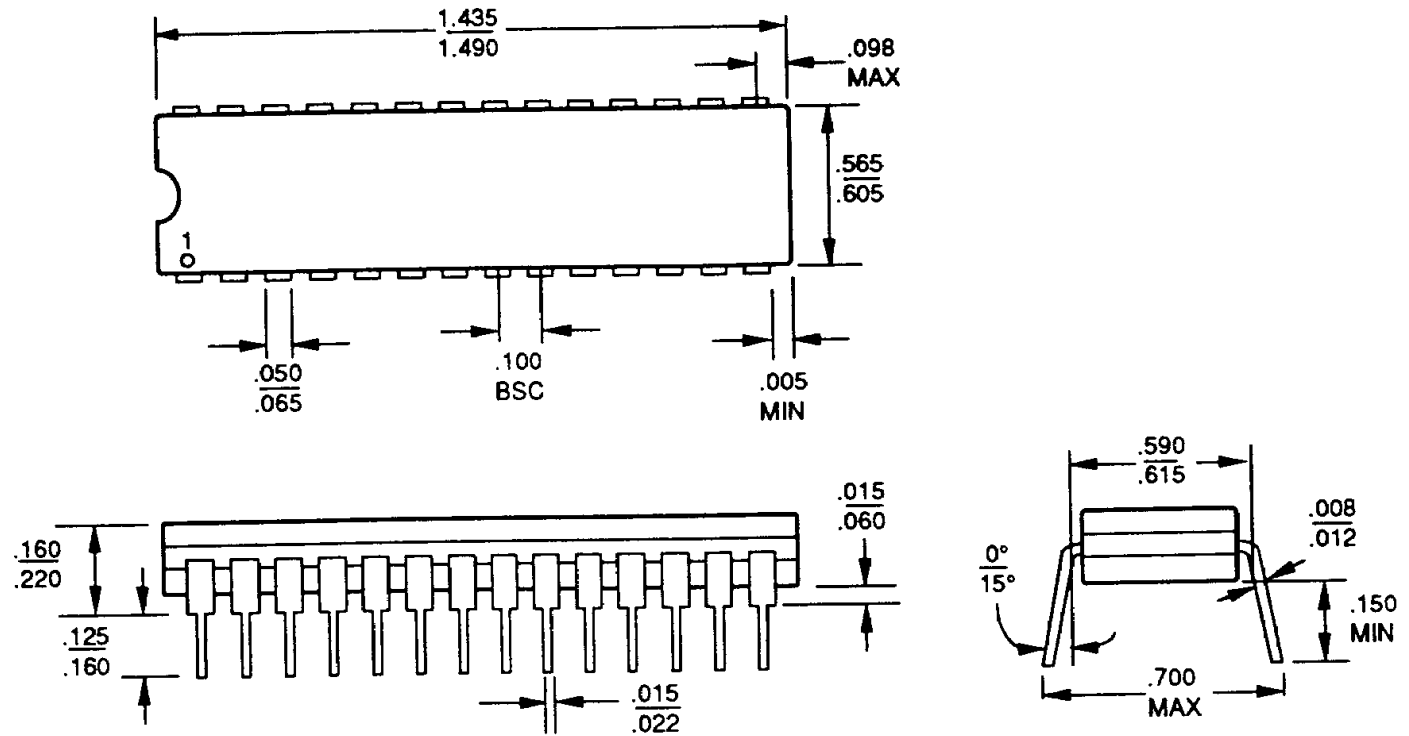

06837C

PHYSICAL DIMENSIONS (continued)

PL 028

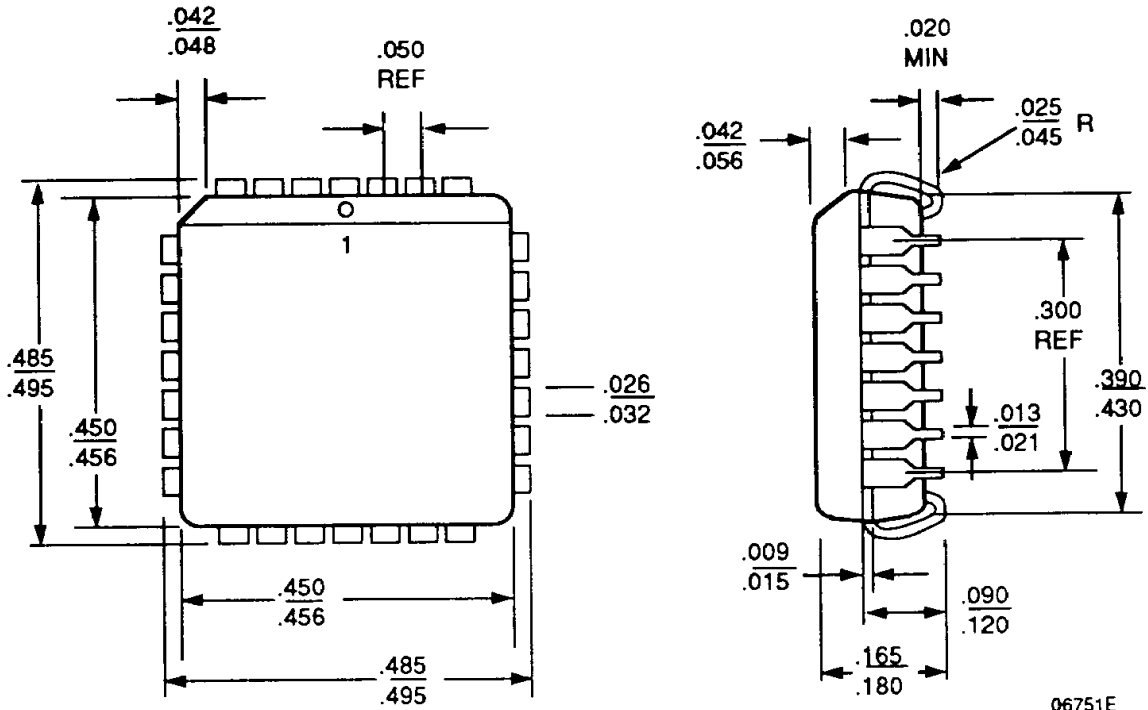

Advanced Micro Devices reserves the right to make changes in its product without notice in order to improve design or performance characteristics. The performance characteristics listed in this document are guaranteed by specific tests, guard banding, design and other practices common to the industry. For specific testing details, contact your local AMD sales representative. The company assumes no responsibility for the use of any circuits described herein.



Advanced Micro Devices, Inc. 901 Thompson Place, P.O. Box 3453, Sunnyvale, CA 94088, USA
 Tel: (408) 732-2400 • TWX: 910-339-9280 • TELEX: 34-6306 • TOLL FREE: (800) 538-8450
APPLICATIONS HOTLINE TOLL FREE: (800) 222-9323 • (408) 749-5703

© 1989 Advanced Micro Devices, Inc.
 5/16/89

026725 ✓ - -