

32 K Channel Digital Switch with High Jitter Tolerance, Rate Conversion per Group of 2 Streams (8, 16, 32 or 64 Mbps), and 64 Inputs and 64 Outputs

Data Sheet



January 2006

Features

- 32,768 channel x 32,768 channel non-blocking digital Time Division Multiplex (TDM) switch at 65.536 Mbps or 32.768 Mbps or using a combination of rates
- 16,384 channel x 16,384 channel non-blocking digital TDM switch at 16.384 Mbps
- 8,192 channel x 8,192 channel non-blocking digital TDM switch at 8.192 Mbps
- High jitter tolerance with multiple input clock sources and frequencies
- Up to 64 serial TDM input streams, divided into 32 groups with 2 input streams per group
- Up to 64 serial TDM output streams, divided into 32 groups with 2 output streams per group
- Per-group input and output data rate conversion selection at 65.536 Mbps, 32.768 Mbps, 16.384 Mbps and 8.192 Mbps. Input and output data group rates can differ
- Per-group input bit delay for flexible sampling point selection
- Per-group output fractional bit advancement
- Two sets of output timing signals for interfacing additional devices

Ordering Information

ZL50075GAC	324 Ball PBGA	Trays
ZL50075GAG2	324 Ball PBGA**	Trays

**Pb Free Tin/Silver/Copper

-40°C to +85°C

- Per-channel A-Law/ μ -Law Translation
- Per-channel constant or variable throughput delay for frame integrity and low latency applications
- Per-stream Bit Error Rate (BER) test circuits
- Per-channel high impedance output control
- Per-channel force high output control
- Per-channel message mode
- Control interface compatible with Intel and Motorola 16 bit non-multiplexed buses
- Connection memory block programming
- Supports ST-BUS and GCI-Bus standards for input and output timing
- IEEE 1149.1 (JTAG) test port
- 3.3 V I/O with 5V tolerant inputs; 1.8 V core voltage

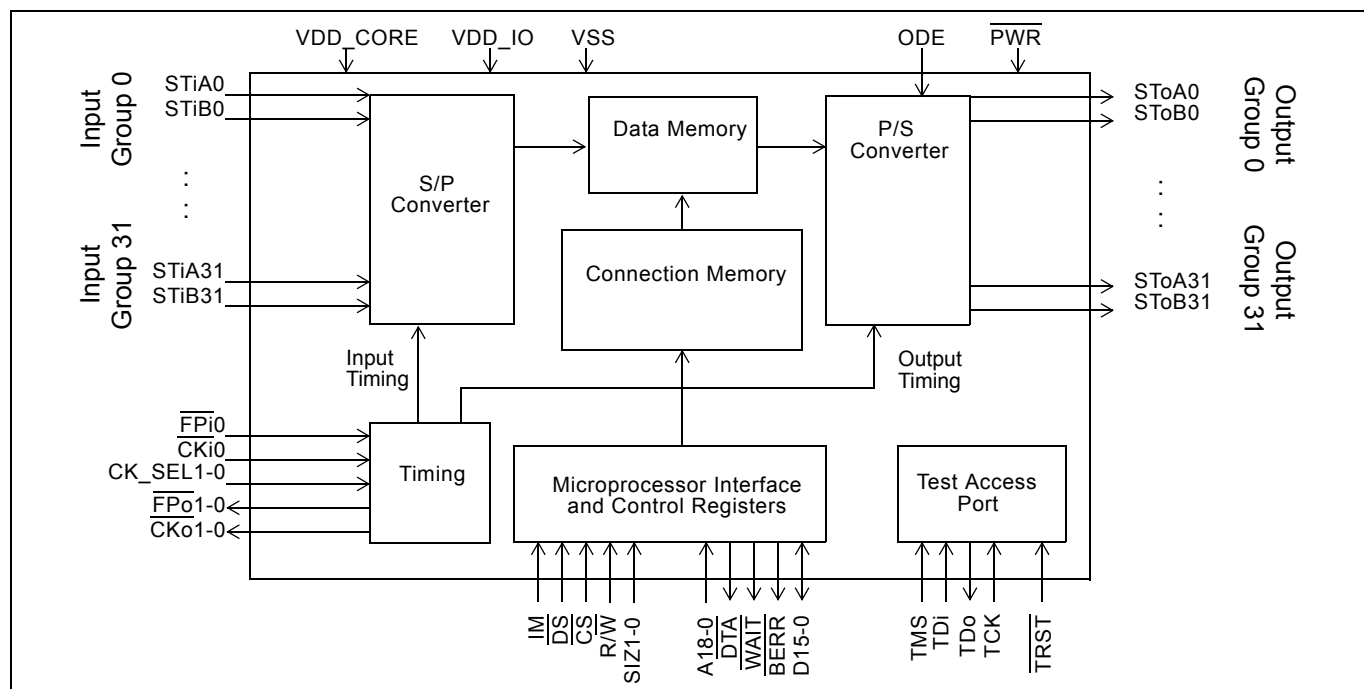

Figure 1 - ZL50075 Functional Block Diagram

Applications

- Large Switching Platforms
- Central Office Switches
- Wireless Base Stations
- Multi-service Access Platforms
- Media Gateways

Description

The ZL50075 is a non-blocking Time Division Multiplex (TDM) switch with maximum 32,768 x 32,768 channels. The device can switch 64 kbps and Nx64 kbps TDM channels from any input stream to any output stream. With a number of enhanced features, the ZL50075 is designed for high capacity voice and data switching applications.

The ZL50075 has 64 input and 64 output data streams which can operate at 8.192 Mbps, 16.384 Mbps, 32.768 Mbps or 65.536 Mbps. The large number of inputs and outputs maintains full 32 K x 32 K channel switching capacity at bit rates of 65 Mbps and 32 Mbps. Up to 32 input and output data streams may operate at 65 Mbps. Up to 64 input and output data streams may operate at 32 Mbps, 16 Mbps or 8 Mbps. The data rate can be independently set in groups of 2 input or output streams. In this way it is possible to provide rate conversion from input data channel to output data channel.

The ZL50075 uses a master clock ($\overline{CKi0}$) and frame pulse ($\overline{FPi0}$) to define the TDM data stream frame boundary and timing. A high speed system clock is derived internally from $\overline{CKi0}$ and $\overline{FPi0}$. The input and output data streams can independently reference their timings to the input clock or to the internal system clock.

The ZL50075 has a variety of user configurable options designed to provide flexibility when data streams are connected to multiple TDM components or circuits. These include:

- Variable input bit delay and output advancement, to accommodate delays and frame offsets of streams connected through different data paths
- Two timing outputs, $\overline{CKo1} - 0$ and $\overline{FPo1} - 0$, which can be configured independently to provide a variety of clock and frame pulse options
- Support of both ST-BUS and GCI-Bus formats

The ZL50075 also has a number of value added features for voice and data applications:

- Per-channel variable delay mode for low latency applications and constant delay mode for frame integrity applications
- Per-channel A-Law/ μ -Law Conversions for both voice and data
- 64 separate Pseudo-random Bit Sequence (PRBS) test circuits; one per stream. This provides an integrated Bit Error Rate (BER) test capability to facilitate data path integrity checking

The ZL50075 has two major modes of operation: Connection Mode (normal) and Message Mode. In Connection Mode, data bytes received at the TDM inputs are switched to timeslots in the output data streams, with mapping controlled by the Connection Memories. Using Zarlink's Message Mode capability, microprocessor data can be broadcast to the output data streams on a per-channel basis. This feature is useful for transferring control and status information to external circuits or other TDM devices.

A non-multiplexed microprocessor port provides access to the internal Data Memory, Connection Memory and Control Registers used to program ZL50075 options. The port is configurable to interface with either 16 bit Motorola or Intel-type microprocessors.

The mandatory requirements of IEEE 1149.1 standard are supported via the dedicated Test Access Port.

Table of Contents

Features	1
Applications	2
Description	2
Change Summary	7
1.0 Functional Description	13
1.1 Overview	13
1.2 Switch Operation	13
1.3 Stream Provisioning	14
1.4 Input and Output Rate Selection	15
1.4.1 Per Group Rate Selection	15
1.5 Rate Conversion	15
2.0 Input Clock (\overline{CKi}) and Input Frame Pulse (\overline{FPi}) Timing	16
3.0 Output Clock (\overline{CKo}) and Output Frame Pulse (\overline{FPo}) Timing	17
4.0 Output Channel Control	17
5.0 Data Input Delay and Data Output Advancement	17
5.1 Input Sampling Point Delay Programming	17
5.2 Fractional Bit Advancement on Output	18
6.0 Message Mode	19
6.1 Data Memory Read	20
6.2 Connection Memory Block Programming	20
7.0 Data Delay Through the Switching Paths	20
7.1 Constant Delay Mode	20
7.2 Variable Delay Mode	21
8.0 Per-Channel A-Law/m-Law Translation	22
9.0 Bit Error Rate Tester	22
10.0 Microprocessor Port	23
10.1 Bus Operation	25
10.1.1 Read Cycle	25
10.1.2 Write Cycle	26
11.0 Power-up and Initialization of the ZL50075	27
11.1 Device Reset and Initialization	27
11.2 Power Supply Sequencing	27
11.3 Initialization	27
12.0 IEEE 1149.1 Test Access Port	28
12.1 Test Access Port (TAP)	28
12.2 Instruction Register	29
12.3 Test Data Register	29
12.4 Boundary Scan Description Language (BSDL)	29
13.0 Memory Map of ZL50075	30
14.0 Detailed Memory and Register Descriptions	30
14.1 Connection Memory	30
14.1.1 Connection Memory Bit Functions	33
14.1.2 Connection Memory LSB	34
14.2 Data Memory	36
14.3 BER Control Memory and Error Counters	37
14.3.1 Input BER Enable Control Memory	37
14.3.2 BER Counters	38
14.4 Group Control Registers	39
14.5 Input Clock Control Register	42
14.6 Output Clock Control Register	43

Table of Contents

14.7 Block Init Register	45
14.8 Block Init Enable Register	45
15.0 DC/AC Electrical Characteristics	46

List of Figures

Figure 1 - ZL50075 Functional Block Diagram	1
Figure 2 - 32 K x 32 K Channel Basic Switch Configuration	14
Figure 3 - Input and Output Data Rate Conversion Example	16
Figure 4 - Input Sampling Point Delay Programming	18
Figure 5 - Output Bit Advancement Timing	19
Figure 6 - Data Throughput Delay for Constant Delay	21
Figure 7 - Data Throughput Delay for Variable Delay	21
Figure 8 - Example PRBS Timeslot Insertion	23
Figure 9 - Read Cycle Operation	26
Figure 10 - Write Cycle Operation	27
Figure 11 - Frame Pulse Input and Clock Input	49
Figure 12 - ST-Bus Frame Pulse and Clock Output Timing	51
Figure 13 - GCI Frame Pulse and Clock Output Timing	51
Figure 14 - Serial Data Timing to CKi	53
Figure 15 - Serial Data Timing to CKo	55
Figure 16 - Microprocessor Bus Interface Timing	57
Figure 17 - Intel Mode Timing	57
Figure 18 - IEEE 1149.1 Test Port & $\overline{\text{PWR}}$ Reset Timing	58

List of Tables

Table 1 - Data Rate and Maximum Switch Size	14
Table 2 - TDM Stream Bit Rates	15
Table 3 - CKi0 and FPi0 Setting via CK_SEL1 - 0	16
Table 4 - Input and Output Voice and Data Coding	22
Table 5 - Example of Address and Byte Significance	24
Table 6 - Byte Enable Signals	24
Table 7 - Memory Data Word Alignment	24
Table 8 - Data Bus Word Alignment	24
Table 9 - Byte Address Examples	25
Table 10 - Memory Map	30
Table 11 - Connection Memory Group Address Mapping	31
Table 12 - Connection Memory Stream Address Offset at Various Output Rates	31
Table 13 - Connection Memory Timeslot Address Offset Range	32
Table 14 - Connection Memory Bits (CMB)	33
Table 15 - Connection Memory LSB Group Address Mapping	35
Table 16 - Connection Memory LSB Stream Address Offset at Various Output Rates	35
Table 17 - Data Memory Group Address Mapping	36
Table 18 - Data Memory Stream Address Offset at Various Output Rates	36
Table 19 - BER Enable Control Memory Group Address Mapping	37
Table 20 - BER Enable Control Memory Stream Address Offset at Various Output Rates	38
Table 21 - BER Counter Group and Stream Address Mapping	38
Table 22 - Group Control Register Addressing	39
Table 23 - Group Control Register	39
Table 24 - Input Clock Control Register	42
Table 25 - Output Clock Control Register	43
Table 26 - Block and Power-up Initialization Status Bits	45

Change Summary

The following table captures the changes from the April 2005 issue.

Page	Item	Change
25	10.1.1, "Read Cycle"	Clarified $\overline{\text{WAIT}}$ signal description in Read Cycle.
26	Figure 9 "Read Cycle Operation"	Corrected $\overline{\text{WAIT}}$ signal tristate timing in Read Cycle.
26	10.1.2, "Write Cycle"	Clarified $\overline{\text{WAIT}}$ signal description in Write Cycle.
27	Figure 10 "Write Cycle Operation"	Corrected $\overline{\text{WAIT}}$ signal tristate timing in Write Cycle.
38	Table 21 "BER Counter Group and Stream Address Mapping"	Corrected BER Counter Group and Stream Mapping Addresses.

The following table captures the changes from the July 2004 issue.

Page	Item	Change
10	"Pin Description" - CKo0-1	Added special requirement for using output clock at 65.536 MHz.
11	"Pin Description" - $\overline{\text{DTA}}$, $\overline{\text{WAIT}}$	Added more detailed description to the $\overline{\text{DTA}}$ and $\overline{\text{WAIT}}$ pins.
48	"AC Electrical Characteristics1 - FPI0 and CKI0 Timing"	Added t_{FPIS} , t_{FPIH} (input frame pulse setup and hold) maximum values.
50	(1) "AC Electrical Characteristics1 - FPO0-1 and CKO0-1 (65.536 MHz) Timing" (2) "AC Electrical Characteristics1 - FPO0-1 and CKO0-1 (32.768 MHz) Timing" (3) "AC Electrical Characteristics1 - FPO0-1 and CKO0-1 (16.384 MHz) Timing" (4) "AC Electrical Characteristics1 - FPO0-1 and CKO0-1 (8.192 MHz) Timing"	Added $\overline{\text{CKO0-1}}$ and $\overline{\text{FPO0-1}}$ setup and hold parameters for all different clock rates.
51	"AC Electrical Characteristics - Output Clock Jitter Generation"	Added this table to specify $\overline{\text{CKO0-1}}$ jitter generation.
52	"AC Electrical Characteristics1 - Serial Data Timing2 to CKi"	(1) Values of parameters t_{SIPS} , t_{SIPH} , t_{SINS} , t_{SINH} , t_{SIPV} , t_{SINV} , t_{SIPZ} and t_{SINZ} are revised. (2) Separated parameter t_{CKD} into t_{CKDP} and t_{CKDN} .
53	Figure 14 "Serial Data Timing to CKi"	Added more detail to figure.
54	"AC Electrical Characteristics - Serial Data Timing1 to CKo2"	(1) Values of parameters t_{SOPS} , t_{SOPH} , t_{SONS} , t_{SONH} , t_{SOPV} , t_{SONV} , t_{SOPZ} and t_{SONZ} are revised. (2) Added $\overline{\text{CKO}}$ skew parameter, t_{CKOS} . (clock source to internal APLL).
55	Figure 15 "Serial Data Timing to CKo"	Added more detail and t_{CKOS} to figure.

Pin Diagram - ZL50075 19 mm x 19 mm 324 Ball PBGA (as viewed through top of package)

A1 corner identified by metallized marking.

	1	2	3	4	5	6	7	8	9	10	11	12	13	14	15	16	17	18
A	D[15]	D[14]	D[5]	D[4]	D[3]	A[18]	A[17]	A[13]	A[12]	A[11]	A[8]	A[4]	A[2]	A[0]	R \bar{W}	$\bar{D}\bar{S}$	IC	$\bar{D}\bar{T}\bar{A}$
B	STOA [1]	IM	D[11]	D[10]	D[8]	D[7]	D[6]	D[1]	A[15]	A[10]	A[5]	A[1]	NC	$\bar{C}\bar{S}$	SIZ[0]	$\bar{P}\bar{W}\bar{R}$	STOA [31]	SIZ[1]
C	STIA [2]	STIB [1]	STIA [0]	STIB [0]	STOA [0]	D[13]	D[9]	D[0]	A[14]	A[9]	A[6]	$\bar{B}\bar{E}\bar{R}\bar{R}$	$\bar{W}\bar{A}\bar{I}\bar{T}$	STIB [31]	TDO	STIA [31]	$\bar{T}\bar{R}\bar{S}\bar{T}$	NC
D	STOB [2]	$\bar{C}\bar{K}\bar{O}$ [0]	STIA [1]	STOB [0]	VDD CORE	D[12]	D[2]	VDD CORE	A[16]	VDD IO	A[7]	A[3]	VDD IO	TCK	VDD CORE	TMS	STOB [30]	STOB [31]
E	STIA [3]	STIB [2]	STOB [1]	$\bar{F}\bar{P}\bar{O}$ [0]	VSS	VSS	VDD CORE	VDD IO	VSS	VDD CORE	VDD IO	VSS	VDD CORE	VDD IO	TDI	STOA [30]	STIB [30]	STIA [30]
F	STOB [3]	STIB [3]	STOA [2]	VDD CORE	VDD IO	VSS	VSS	VDD CORE	VDD IO	VSS	VDD CORE	VDD IO	VSS	VDD CORE	STOB [29]	STIB [29]	STOA [29]	STIA [29]
G	STOA [3]	STIB [4]	STIA [4]	VDD IO	VDD CORE	VDD IO	VSS	VSS	VSS	VSS	VSS	VSS	VDD IO	VSS	VDD IO	STIB [28]	STOB [28]	STOA [28]
H	VSS	VSS	STOA [4]	STOB [4]	VSS	VDD CORE	VSS	VSS	VSS	VSS	VSS	VSS	VDD CORE	VDD IO	VSS	STOA [27]	STOB [27]	STIA [28]
J	STIA [5]	STOA [5]	STIB [5]	STOB [5]	VDD IO	VSS	VSS	VSS	VSS	VSS	VSS	VSS	VSS	VDD CORE	STOA [26]	STOB [26]	VSS	STIB [27]
K	ODE	STIA [6]	STIA [7]	STOA [6]	VDD CORE	VDD IO	VSS	VSS	VSS	VSS	VSS	VSS	VDD IO	VSS	STIB [25]	IC	STOA [25]	STIA [27]
L	STIB [6]	STOB [6]	IC	STIA [8]	VSS	VDD CORE	VSS	VSS	VSS	VSS	VSS	VSS	VDD CORE	VDD IO	STIA [24]	STOA [24]	STOB [24]	IC
M	STIB [7]	STOA [7]	STOB [8]	VDD CORE	VDD IO	VDD IO	VSS	VSS	VSS	VSS	VSS	VSS	VDD IO	VDD CORE	VDD CORE	STIA [23]	STOB [23]	STIB [26]
N	STOB [7]	STIB [8]	STIB [9]	VDD IO	VDD CORE	VSS	VSS	VDD CORE	VDD IO	VSS	VDD CORE	VDD IO	VSS	VSS	VDD IO	STOA [22]	STOB [22]	STIA [26]
P	IC	STIA [9]	STIA [10]	STOB [10]	VSS	VSS	VDD CORE	VDD IO	VSS	VDD CORE	VSS	VSS	VDD CORE	VDD IO	STOA [21]	STOB [21]	NC	STOB [25]
R	STOA [8]	STOB [9]	STOA [10]	STIA [12]	VDD IO	STOA [13]	STIA [15]	VDD CORE	STOA [15]	VDD IO	STIB [17]	IC	VDD IO	STIB [19]	VDD CORE	STIA [21]	STIA [22]	STIA [25]
T	STOA [9]	STIB [10]	STIA [11]	STOA [11]	STOA [12]	STIA [13]	STOB [13]	STIB [15]	STOB [16]	$\bar{F}\bar{P}\bar{I}$ [0]	STIA [17]	IC	STIA [18]	STIA [19]	STIA [20]	STOA [20]	NC	STIB [24]
U	STIB [11]	STOB [11]	STIB [12]	$\bar{C}\bar{K}\bar{O}$ [1]	STIA [14]	STIB [14]	STOB [15]	STIA [16]	STOA [16]	IC	NC	STOB [17]	CK_SEL[0]	STOB [18]	STOB [19]	STOB [20]	STIB [21]	STOA [23]
V	STOB [12]	$\bar{F}\bar{P}\bar{O}$ [1]	STIB [13]	STOA [14]	STOB [14]	STIB [16]	$\bar{C}\bar{K}\bar{I}$ [0]	NC	IC	IC	STOA [17]	CK_SEL[1]	STIB [18]	STOA [18]	STOA [19]	STIB [20]	STIB [22]	STIB [23]

Pin Description

Pin	Name	Description
TDM Interface		
C3, D3, C1, E1, G3, J1, K2, K3, L4, P2, P3, T3, R4, T6, U5, R7, U8, T11, T13, T14, T15, R16, R17, M16, L15, R18, N18, K18, H18, F18, E18, C16,	STiA0-31	Serial TDM Input Data 'A' Streams (5 V Tolerant Input with Internal Pull-down) The data rate of these input streams can be selected in a group of 2 to be either 8.192 Mbps, 16.384 Mbps, 32.678 Mbps or 65.536 Mbps. Refer to Section 1.4 for rate programming options. The data streams can be selected to be either inverted or non-inverted, programmed by the Group Control Registers (Section 14.4). Unused inputs are pulled low by internal pull-down resistors and may be left unconnected.
C4, C2, E2, F2, G2, J3, L1, M1, N2, N3, T2, U1, U3, V3, U6, T8, V6, R11, V13, R14, V16, U17, V17, V18, T18, K15, M18, J18, G16, F16, E17, C14	STiB0-31	Serial TDM Input Data 'B' Streams (5 V Tolerant Input with Internal Pull-down) The data rate of these input streams can be selected in a group of 2 to be either 8.192 Mbps, 16.384 Mbps, or 32.678 Mbps. The stream is unused when its input group rate is 65.536 Mbps. Refer to Section 1.4 for rate programming options. The data streams can be selected to be either inverted or non-inverted, programmed by the Group Control Registers (Section 14.4). Unused inputs are pulled low by internal pull-down resistors and may be left unconnected.
C5, B1, F3, G1, H3, J2, K4, M2, R1, T1, R3, T4, T5, R6, V4, R9, U9, V11, V14, V15, T16, P15, N16, U18, L16, K17, J15, H16, G18, F17, E16, B17	SToA0-31	Serial TDM Output Data 'A' Streams (5 V Tolerant, 3.3 V Tri-state Slew-Rate Controlled Outputs) The data rate of these output streams can be selected in a group of 2 to be either 8.192 Mbps, 16.384 Mbps, 32.678 Mbps or 65.536 Mbps. Refer to Section 1.4 for rate programming options. The data streams can be selected to be either inverted or non-inverted, programmed by the Group Control Registers (Section 14.4).
D4, E3, D1, F1, H4, J4, L2, N1, M3, R2, P4, U2, V1, T7, V5, U7, T9, U12, U14, U15, U16, P16, N17, M17, L17, P18, J16, H17, G17, F15, D17, D18	SToB0-31	Serial TDM Output Data 'B' Streams (5 V Tolerant, 3.3 V Tri-state Slew-Rate Controlled Outputs) The data rate of these output streams can be selected in a group of 2 to be either 8.192 Mbps, 16.384 Mbps or 32.678 Mbps. The stream is unused when its output group rate is 65.536 Mbps. Refer to Section 1.4 for rate programming options. The data streams can be selected to be either inverted or non-inverted, programmed by the Group Control Registers (Section 14.4). Unused outputs are tristated and may be left unconnected.
V7	$\overline{\text{CKi0}}$	ST-BUS/GCI-Bus Clock Input (5 V Tolerant Schmitt-Triggered Input) This pin accepts an 8.192 MHz, 16.384 MHz, 32.678 MHz or 65.536 MHz clock. This clock must be provided for correct operation of the ZL50075. The frequency of the $\overline{\text{CKi0}}$ input is selected by the CK_SEL1-0 inputs. The active clock edge may be either rising or falling, programmed by the Input Clock Control Register (Section 14.5).

Pin Description (continued)

Pin	Name	Description
T10	$\overline{\text{FPi0}}$	ST-BUS/GCI-Bus Frame Pulse Input (5 V Tolerant Input) This pin accepts the 8 kHz frame pulse which marks the frame boundary of the TDM data streams. The pulse width is nominally one CKi0 clock period (assuming ST-BUS mode) selected by the CK_SEL1-0 inputs. The active state of the frame pulse may be either high or low, programmed by the Input Clock Control Register (Section 14.5).
D2, U4	$\overline{\text{CKo0-1}}$	ST-BUS/GCI-Bus Clock Outputs (3.3 V Outputs with Slew-Rate Control) These clock outputs can be programmed to generate 8.192 MHz, 16.384 MHz, 32.678 MHz or 65.536 MHz TDM clock outputs. The active edge can be programmed to be either rising or falling. The source of the clock outputs can be derived from either the CKi0 inputs or the internal system clock. The frequency, active edge and source of each clock output can be programmed independently by the Output Clock Control Register (Section 14.6). For 65.536 MHz output clock, the total loading on the output should not be larger than 10pF.
E4, V2	$\overline{\text{FPo0-1}}$	ST-BUS/GCI-Bus Frame Pulse Outputs (3.3 V Outputs with Slew-Rate Control) These 8 kHz output pulses mark the frame boundary of the TDM data streams. The pulse width is nominally one clock period of the corresponding CKo output. The active state of each frame pulse may be either high or low, independently programmed by the Output Clock Control Register (Section 14.6).
U13, V12	CK_SEL0-1	TDM Master Clock Input Select Inputs used to select the frequency and frame alignment of CKi0 and FPi0: CK_SEL1 = 0, CK_SEL0 = 0, 8.192 MHz CK_SEL1 = 0, CK_SEL0 = 1, 16.384 MHz CK_SEL1 = 1, CK_SEL0 = 0, 32.768 MHz CK_SEL1 = 1, CK_SEL0 = 1, 65.536 MHz
K1	ODE	Output Drive Enable (5 V Tolerant Input with Internal Pull-up) This is the asynchronous output enable control for the output streams. When it is high, the streams are enabled. When it is low, the output streams are tristated.
Microprocessor Port and Reset		
A1, A2, C6, D6, B3, B4, C7, B5, B6, B7, A3, A4, A5, D7, B8, C8	D15-0	Microprocessor Port Data Bus (5 V Tolerant Bi-directional with Slew-Rate Output Control) 16 bit bi-directional data bus. Used for microprocessor access to internal memories and registers.
A6, A7, D9, B9, C9, A8, A9, A10, B10, C10, A11, D11, C11, B11, A12, D12, A13, B12, A14	A18-0	Microprocessor Port Address Bus (5 V Tolerant Inputs) 19 bit address bus for the internal memories and registers. Note A0 is not used and should be connected to a defined logic level.

Pin Description (continued)

Pin	Name	Description
B14	\overline{CS}	Chip Select Input (5 V Tolerant Input) Active low input used with \overline{DS} to enable read and write access to the ZL50075.
A16	\overline{DS}	Data Strobe Input (5 V Tolerant Input) Active low input used with \overline{CS} to enable read and write access to the ZL50075.
A15	$\overline{R/W}$	Read/Write Input (5 V Tolerant Input) Input signal that controls the type of microprocessor access: 0 - Microprocessor write to the ZL50075 1 - Microprocessor read from the ZL50075
A18	\overline{DTA}	Data Transfer Acknowledge (5 V Tolerant, 3.3 V Tri-state Output with Slew-Rate) Active low output which indicates that a data bus transfer is complete. An external pull-up resistor is required to hold this pin HIGH when output is high-impedance.
C12	\overline{BERR}	Transfer Bus Error Output with Slew Rate Control (5 V Tolerant, 3.3 V Tri-state Outputs with Slew-Rate Control) This pin goes low whenever the microprocessor attempts to access an invalid memory space inside the device. In Motorola bus mode, if this bus error signal is activated, the data transfer acknowledge signal, \overline{DTA} , will not be generated. In Intel bus mode, the generation of the \overline{DTA} is not affected by this \overline{BERR} signal. An external pull-up resistor is required to hold a HIGH level when output is high-impedance.
C13	\overline{WAIT}	Data Transfer Wait Output (5 V Tolerant, 3.3 V Tri-state Output with Slew Rate) Active low wait signal output. An external pull-up resistor is required to hold a HIGH level when output is high-impedance.
B15, B18	SIZ0-1	Data Transfer Size/Upper and Lower Data Strobe Inputs (5 V Tolerant Inputs) Motorola mode: SIZ0 - \overline{LDS} , SIZ1 - \overline{UDS} . Active low upper and lower data strobes, \overline{UDS} and \overline{LDS} , indicate whether the upper byte, D15-8, and/or lower byte, D7-0, is being transferred. Intel mode: SIZ0 - $\overline{BE0}$, SIZ1 - $\overline{BE1}$. Active low Intel type bus-enable signal $\overline{BE1}$ and $\overline{BE0}$ signals
B2	IM	Microprocessor Port Bus Mode Select (5 V Tolerant Input) Control input: 0 = Motorola mode 1 = Intel mode
B16	\overline{PWR}	Device Reset (5 V Tolerant Schmitt-Triggered Input) Asynchronous reset input used to initialize the ZL50075. 0 = Reset 1 = Normal See Section 11.0, Power-up and Initialization of the ZL50075 for detailed description of Reset state.

Pin Description (continued)

Pin	Name	Description
IEEE 1149.1 (JTAG) Test Access Port (TAP)		
E15	TDI	Test Data (5 V Tolerant Input with Internal Pull-up) Serial test data input. When not used, this input may be left unconnected.
C15	TDO	Test Data (3.3 V Output) Serial test data output.
D14	TCK	Test Clock (5 V Tolerant Schmitt-Triggered Input with Internal Pull-up) Clock input used by TAP Controller. When not used, this input may be left unconnected.
D16	TMS	Test Reset (5 V Tolerant Schmitt-Triggered Input with Internal Pull-up) Input which controls the state transitions of the TAP Controller. When not used, this pin is pulled high by an internal pull-up resistor and may be left unconnected.
C17	$\overline{\text{TRST}}$	Test Mode Select (5 V Tolerant Input with Internal Pull-up) Asynchronously initializes the JTAG TAP controller by putting it in the Test-Logic-Reset state. This pin should be pulsed low during power-up to ensure that the device is in the normal functional mode. When JTAG is not being used, this pin should be pulled low during normal operation.
Unused		
U10, V9, V10, R12, L18, A17, L3, P1, T12, K16	IC	Internal Connections In normal mode these pins MUST be connected low.
B13, C18, P17, T17, U11, V8	NC	No Connection In normal mode these pins MUST be left unconnected.
Power		
E5, E6, E9, E12, F6, F7, F10, F13, G7, G8, G9, G10, G11, G12, G14, H1, H2, H5, H7, H8, H9, H10, H11, H12, H15, J6, J7, J8, J9, J10, J11, J12, J13, J17, K7, K8, K9, K10, K11, K12, K14, L5, L7, L8, L9, L10, L11, L12, M7, M8, M9, M10, M11, M12, N6, N7, N10, N13, N14, P5, P6, P9, P11, P12	V _{SS}	Ground
D5, D8, D15, E7, E10, E13, F4, F8, F11, F14, G5, H6, H13, J14, K5, L13, L6, M4, M14, M15, N5, N8, N11, P7, P10, P13, R8, R15	V _{DD_CORE}	Power Supply for the Core Logic: +1.8 V

Pin Description (continued)

Pin	Name	Description
D10, D13, E8, E11, E14, F5, F9, F12, G4, G6, G13, G15, H14, J5, K6, K13, L14, M5, M6, M13, N4, N9, N12, N15, P8, P14, R5, R10, R13	V _{DD_IO}	Power Supply for the I/O: +3.3 V

1.0 Functional Description**1.1 Overview**

The device has 64 ST-BUS/GCI-Bus inputs (STiA0 - 31 and STiB0 - 31) and 64 ST-BUS/GCI-Bus outputs (SToA0 - 31 and SToB0 - 31). It is a non-blocking digital switch with 32,768 64 kbps channels and is capable of performing rate conversion between groups of 2 inputs and 2 outputs. The inputs accept serial input data streams with data rates of 8.192 Mbps, 16.384 Mbps, 32.768 Mbps or 65.536 Mbps. There are 32 input groups with each group consisting of 2 streams ('A' and 'B'). Each group can be set to any of the data rates. The outputs deliver serial data streams with data rates of 8.192 Mbps, 16.384 Mbps, 32.768 Mbps or 65.536 Mbps. There are 32 output groups with each group consisting of 2 streams ('A' and 'B'). Each group can be set to any of the data rates.

By using Zarlink's message mode capability, the microprocessor can store data in the connection memory which can be broadcast to the output streams on a per-channel basis. This feature is useful for transferring control and status information for external circuits or other ST-BUS/GCI-Bus devices.

The ZL50075 uses the ST-BUS/GCI-Bus master input frame pulse ($\overline{FPi0}$) and the ST-BUS/GCI-Bus master input clock ($\overline{CKi0}$) to define the input frame boundary and timing for sampling the ST-BUS/GCI-Bus input streams with various data rates (8.192 Mbps, 16.384 Mbps, 32.768 Mbps or 65.536 Mbps). The rate of the input clock is defined by setting the CK_SEL1 - 0 pins.

A selectable Motorola or Intel compatible non-multiplexed microprocessor port allows users to program the device to operate in various modes under different switching configurations. Users can use the microprocessor port to perform internal register and memory read and write operations. The microprocessor port has 16 bit data bus and 17 bit address bus (in A18-0, A0 is not used, and A1 is used for word alignment). There are seven control signals (CS, DS, R/W, DTA, WAIT, BERR and IM).

The device supports the mandatory requirements for the IEEE 1149.1 (JTAG) standard via the test port.

1.2 Switch Operation

The ZL50075 switches 64 kbps and Nx64 kbps data and voice channels from the TDM input streams, to timeslots in the TDM output streams. The device is non-blocking; all 32 K input channels can be switched through to the outputs. Any input channel can be switched to any available output channel.

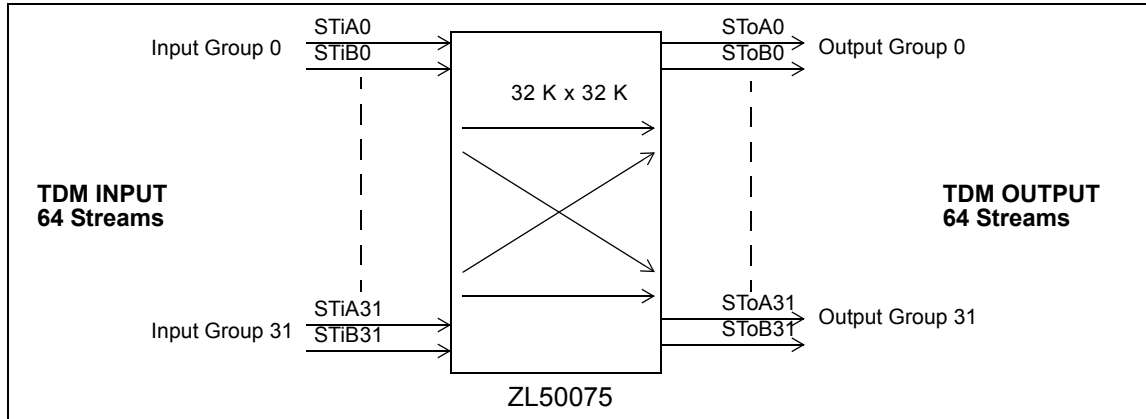

Figure 2 - 32 K x 32 K Channel Basic Switch Configuration

The maximum channel switching capacity is determined by the number of streams and their rate of operation, as shown in Table 1.

TDM Group Data Rate	Maximum Number of Input TDM Data Streams	Maximum Number of Output TDM Data Streams	Number of 64 kbps Channels per Stream	Maximum Switch Capacity [†] (streams x channels = total)
65.536 Mbps	32	32	1024	32 x 1024 = 32,768
32.768 Mbps	64	64	512	64 x 512 = 32,768
16.384 Mbps	64	64	256	64 x 256 = 16,384 [‡]
8.192 Mbps	64	64	128	64 x 128 = 8,192 [‡]

Table 1 - Data Rate and Maximum Switch Size

[†] The maximum capacity shown is when all streams are at the same rate, and none are operating at 16.384 Mbps or 8.192 Mbps.

[‡] Switch capacity is limited to less than 32 K channels, only when streams are provisioned at 16 Mbps or 8 Mbps. The maximum switch capacity in this case is given by $32,768 - (M \times 256) - (N \times 384)$, where M is the number of 16 Mbps input or output streams, and N is the number of 8 Mbps input or output streams.

1.3 Stream Provisioning

The ZL50075 is a large switch with a comprehensive list of user configurable, 'per-group' programmable features. In order to facilitate ease of use, the ZL50075 offers a simple programming model. Streams are grouped in sets of two, with each group sharing the same configured characteristics. In this way it is possible to reduce programming complexity, while still maintaining flexible 'per-stream' configuration options:

- Input and output rate selection, see Section 1.4
- Input stream clock source selection, see Section 2.0
- Output stream clock source selection, see Section 2.0
- Input stream sampling point selection, see Section 5.1
- Output stream fractional bit advance, see Section 5.2
- Input and output stream inversion control, see Section 14.4

The streams are grouped, one from the TDM 'A' streams, combined with the corresponding 'B' streams. For example, input stream group #12 is STiA12 and STiB12, and output stream group #4 is SToA4 and SToB4. There are 32 input and 32 output groups. Depending on the data rate set for the group there will be between 1 and 2 streams activated. If the data rate is set for 65.536 Mbps, the 'A' stream will be activated and the 'B' stream will not be activated. If the data rate is set for 32.768 Mbps, 16.384 Mbps or 8.192 Mbps, the 'A' and 'B' streams will be activated. The maximum channel capacity of a group is 1024 channels when operating at 65 Mbps or 32 Mbps. The

switch capacity is reduced to 512 channels when operating at 16 Mbps and to 256 channels when operating at 8 Mbps.

1.4 Input and Output Rate Selection

Table 1 shows the maximum number of streams available at different bit rates. The ZL50075 deactivates unused streams when operating at the higher bit rates as shown in Table 2.

Input or Output Group n (n = 0 - 31)	65 Mbps	32 Mbps	16 Mbps	8 Mbps
STiAn / SToAn	Active	Active	Active	Active
STiBn / SToBn	Not Active	Active	Active	Active

Table 2 - TDM Stream Bit Rates

For 65 Mbps operation, only those inputs and outputs in the TDM 'A' streams are active. For 32 Mbps, 16 Mbps and 8 Mbps operation, the inputs and outputs in the TDM 'A' and 'B' streams are active.

Note that if the internal system clock is not used as the clock source, there are limitations on the maximum data rate. See Section 2.0 for more details.

1.4.1 Per Group Rate Selection

See Section 14.4, Group Control Registers, for programming details. The data rates are set with the Input Stream Bit Rate (bits 3 - 2) and the Output Stream Bit Rate (bits 19 - 18) in the Group Control Registers 0 - 31 (GCR0 - 31).

For the ZL50075, the bit rates of the inputs and outputs are programmed independently, in groups of 2 streams. Depending on the rate programmed, the active streams in the group will be as indicated in Table 2.

For example:

- if input stream group #1 is programmed for 65 Mbps: STiA1 is active; STiB1 is not active
- if output stream group #15 is programmed for 32 Mbps, 16 Mbps or 8 Mbps: SToA15 and SToB15 are active

1.5 Rate Conversion

The ZL50075 supports rate conversion from any input stream rate to any output stream rate.

An example of ZL50075 rate conversion is given in Figure 3. The output stream rates do not have to follow the input stream rates. In this example, on the input side of the switch you can have 24 streams operating at 65.536 Mbps (24,576 channels - 24 groups with 1 stream in each group), 8 streams operating at 32.768 Mbps (4096 channels - 4 groups with 2 streams in each group) and 8 streams operating at 16.384 Mbps (2048 channels - 4 groups with 2 streams in each group) with no streams operating at 8.192 Mbps. This results in an input capacity of 30,720 input channels. This is less than the full capacity of the device as some groups are operating at less than 32 Mbps. As the output streams do not have to follow the input streams, they can be configured so that 15 streams operate at 65.536 Mbps (15,360 channels - 15 groups with 1 stream in each group), 28 streams operate at 32.768 Mbps (14,336 channels - 14 groups with 2 streams in each group), 2 streams operate at 16.384 Mbps (512 channels - 1 group with 2 streams in the group) and 4 streams operate at 8.192 Mbps (512 channels - 2 groups with 2 streams in each group). This results in an output capacity of 30,720 output channels. This is less than the full capacity of the device as some groups are operating at less than 32 Mbps.

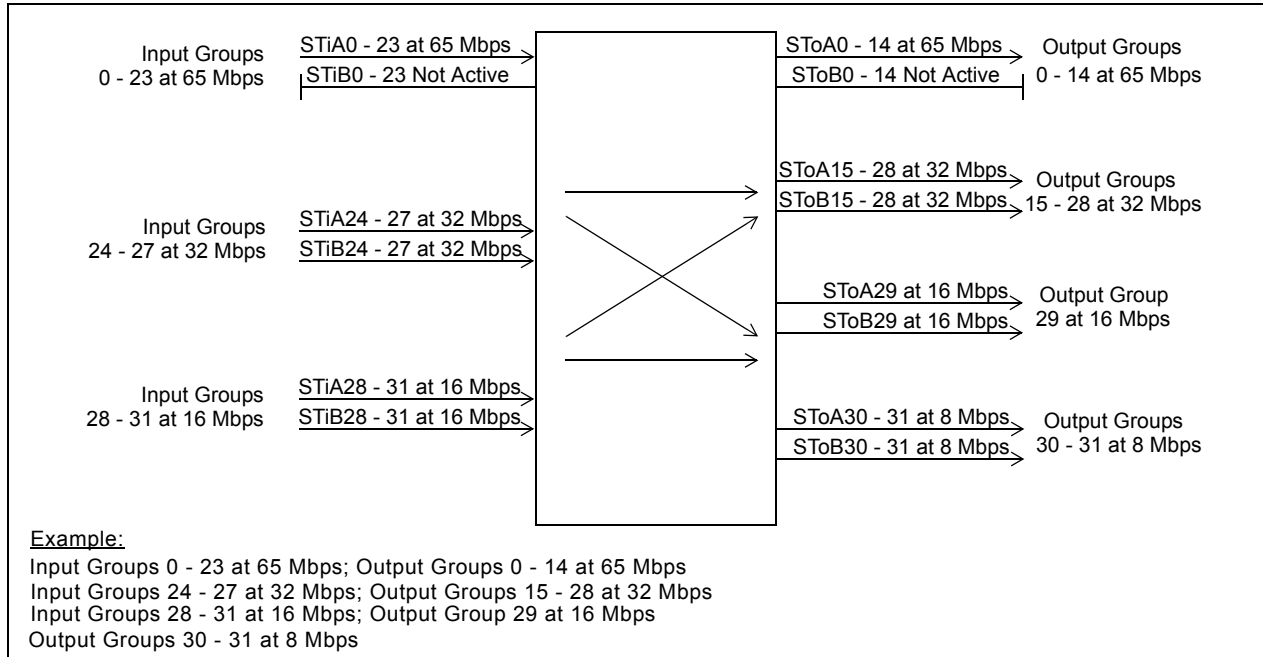

Figure 3 - Input and Output Data Rate Conversion Example

2.0 Input Clock ($\overline{\text{CKi}}$) and Input Frame Pulse ($\overline{\text{FPi}}$) Timing

The input timing for the ZL50075 can be set for one of four different frequencies. They can also be set for ST-BUS or GCI-Bus mode with positive or negative input. The $\overline{\text{CKi0}}$ and $\overline{\text{FPi0}}$ input timing must be provided in order for the device to be used. $\overline{\text{CKi0}}$ is used to generate the internal clock. This clock is used for all the internal logic and can be used as one of the clocks that defines the timing for the input and output data. The input stream clock source is selected by the ISSRC1 - 0 (bits 1 - 0) in the Group Control Register. The output stream clock source is selected by the OSSRC1 - 0 (bits 17 - 16) in the Group Control Register.

The $\overline{\text{CKi0}}$ and $\overline{\text{FPi0}}$ input frequency is set via the CK_SEL1 - 0 pins as shown in Table 3. By default the $\overline{\text{CKi0}}$ and $\overline{\text{FPi0}}$ pins accept ST-BUS, negative input timing. The input frame pulse format (ST-BUS/GCI-Bus), frame pulse polarity, and clock polarity can be programmed by the GCISEL0 (bit 2), FPIPOL0 (bit 1), and CKIPSL0 (bit 0) in the Input Clock Control Register (ICCR), as described in Section 14.5.

CK_SEL1	CK_SEL0	Input $\overline{\text{CKi0}}$ and $\overline{\text{FPi0}}$
0	0	8.192 MHz
0	1	16.384 MHz
1	0	32.768 MHz
1	1	65.536 MHz

Table 3 - $\overline{\text{CKi0}}$ and $\overline{\text{FPi0}}$ Setting via CK_SEL1 - 0

The input streams, output streams, and output clocks / frame pulses can use either the internal system clock or the input $\overline{\text{CKi0}}$ and $\overline{\text{FPi0}}$ as clock sources. The input streams' clock sources are controlled by the ISSRC1-0 (bits 1 - 0) in the Group Control Registers (GCR). The output streams' clock sources are controlled by the OSSRC1-0 (bits 17 - 16) in the Group Control Registers (GCR). The output clocks' / frame pulses' clock sources are controlled by the $\overline{\text{CKO1SRC1-0}}$ (bits 8-7) and $\overline{\text{CKO0SRC1-0}}$ (bits 1-0) in the Output Clock Control Register (OCCR). Using the input $\overline{\text{CKi0}}$ and $\overline{\text{FPi0}}$ as clock source provides a direct interface to jittery peripherals, while using the internal system clock as clock source provides the best data rate and clock rate flexibility.

When the internal system clock is not used as the clock source, there are limitations to the data rate and the output clock rate. For all the input and output stream groups that do not use the internal system clock as their clock source, the data rate is limited to be no higher than the selected clock source's rate (e.g., if $\overline{\text{CKi0}}$ runs at 16.384 MHz and it is selected as the clock source for input stream group 3, then the maximum data rate of STiA3 and STiB3 is 16.384 Mbps). Similarly, for all the output clocks that do not use the internal system clock as their clock source, the clock rate is limited to be no higher than the selected clock source's rate (e.g., if $\overline{\text{CKi0}}$ runs at 32.768 MHz and it is selected as the clock source for output clock $\overline{\text{CKo0}}$, then the maximum clock rate of $\overline{\text{CKo0}}$ is 32.768 MHz).

3.0 Output Clock ($\overline{\text{CKo}}$) and Output Frame Pulse ($\overline{\text{FPo}}$) Timing

There are two output timing pairs, $\overline{\text{CKo1}} - 0$ and $\overline{\text{FPo1}} - 0$. By default these signals generate ST-BUS, negative timing, and use the internal system clock as reference clock source. Their default clock rates are 65.536 MHz for $\overline{\text{CKo0}}$ and 32.768 MHz for $\overline{\text{CKo1}}$. Their properties can also be individually programmed in the Output Clock Control Register (OCCR) to control the frame pulse format (ST-BUS/GCI-Bus), frame pulse polarity, clock polarity, clock rate (8.192 MHz, 16.384 MHz, 32.768 MHz or 65.536 MHz), and reference clock source. Refer to Section 14.6 for programming details. Note that the reference clock source can be set to either the internal system clock or the input $\overline{\text{CKi0}}$ and $\overline{\text{FPI0}}$ signals. If the input $\overline{\text{CKi0}}$ and $\overline{\text{FPI0}}$ is selected as the reference source, the output clock cannot be programmed to generate a higher clock frequency than the reference source. As each output timing pair has its own bit settings, they can be set to provide different output timings. For 65.536 MHz output clock, the total loading on the output should not be larger than 10pF.

4.0 Output Channel Control

To be able to interface with external buffers, the output signals can be set to enter a high impedance or drive high state on a per-channel basis. The Per Channel Function (bits 31 - 29) in the Connection Memory Bits can be set to 001 to drive the channel output high, or to 000, 110 or 111 to set the channel into a high impedance state.

5.0 Data Input Delay and Data Output Advancement

The Group Control Registers (GCR) are used to adjust the input delay and output advancement for each input and output data groups. Each group is independently programmed.

5.1 Input Sampling Point Delay Programming

The input sampling point delay programming feature provides users with the flexibility of handling different wire delays when incoming traffic is from different sources.

By default, all input streams have zero delay, such that bit 7 is the first bit that appears after the input frame boundary (assuming ST-BUS formatting). The nominal input sampling point with zero delay is at the 3/4 bit time. The input delay is enabled by the Input Sample Point Delay (bit 8 - 4) in the Group Control Registers 0 - 31 (GCR0 - 31) as described in Section 14.4 on page 39. The input sampling point delay can range from 0 to 7 3/4 bit delay with a 1/4 bit resolution on a per group basis.

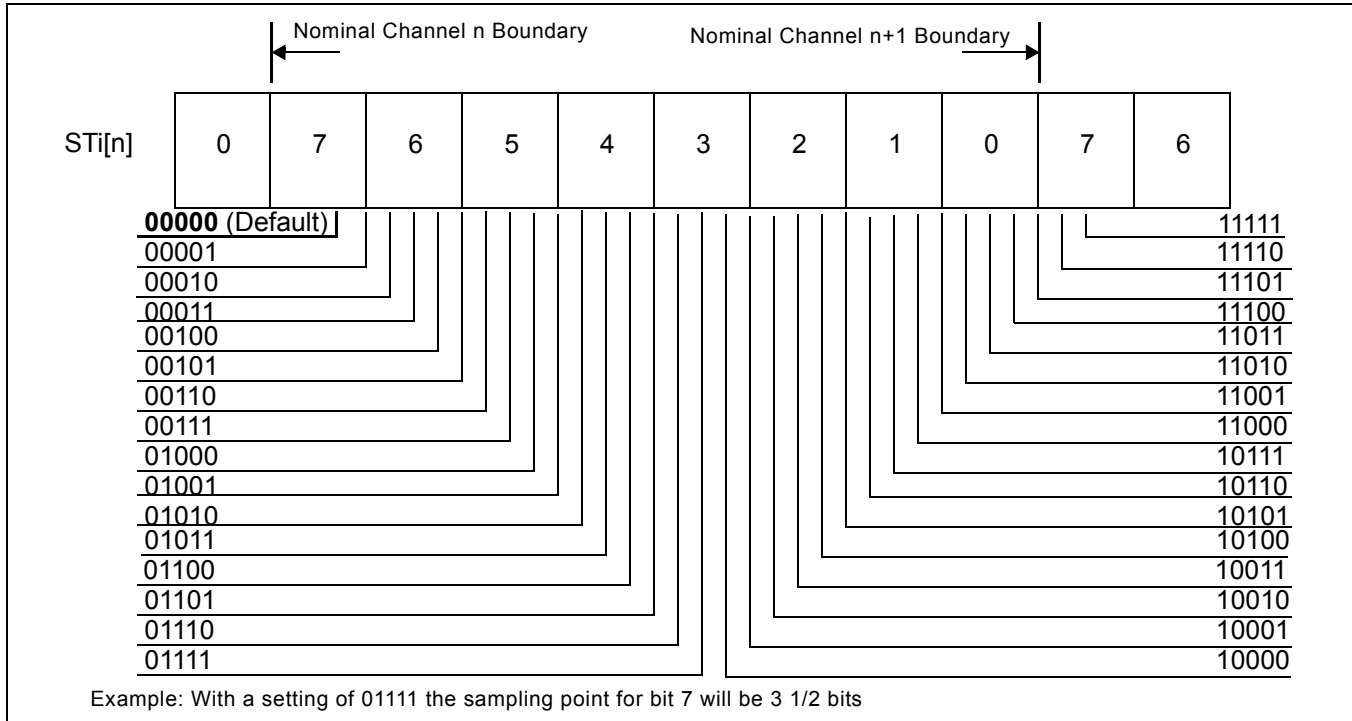

Figure 4 - Input Sampling Point Delay Programming

There are limitations when the ZL50075 is programmed to use $\overline{CKi0}$ as the input stream clock source as opposed to the internal clock:

- The granularity of the delay becomes 1/2 the selected reference clock period, or 1/4 bit, whichever is longer
- If the selected reference clock frequency is the same as the stream bit rate, the granularity of the delay is 1/2 bit. In this case, the least significant bit of the ISPD register is not used; the remaining 4 bits select the total delay in 1/2 bit increments, to a maximum of 7 1/2 bits. Also, the 0 bit delay reference point changes from the 3/4 bit position to the 1/2 bit position.

5.2 Fractional Bit Advancement on Output

See Section 14.4, Group Control Registers, for programming details.

This feature is used to advance the output data with respect to the output frame boundary. Each group has its own bit advancement value which can be programmed in the Group Control Registers 0 - 31 (GCR0 - 31).

By default all output streams have zero bit advancement such that bit 7 is the first bit that appears after the output frame boundary (assuming ST-BUS formatting). The output advancement is enabled by the Output Stream Bit Advancement (bits 21 - 20) of the Group Control Registers 0 - 31 (GCR0 - 31), as described in Section 14.4. The output delay can vary from 0 to 22.8 ns with a 7.6 ns increment. The exception to this is output streams programmed at 65 Mbps, in which case the increment is 3.8 ns with a total advancement of 11.4 ns.

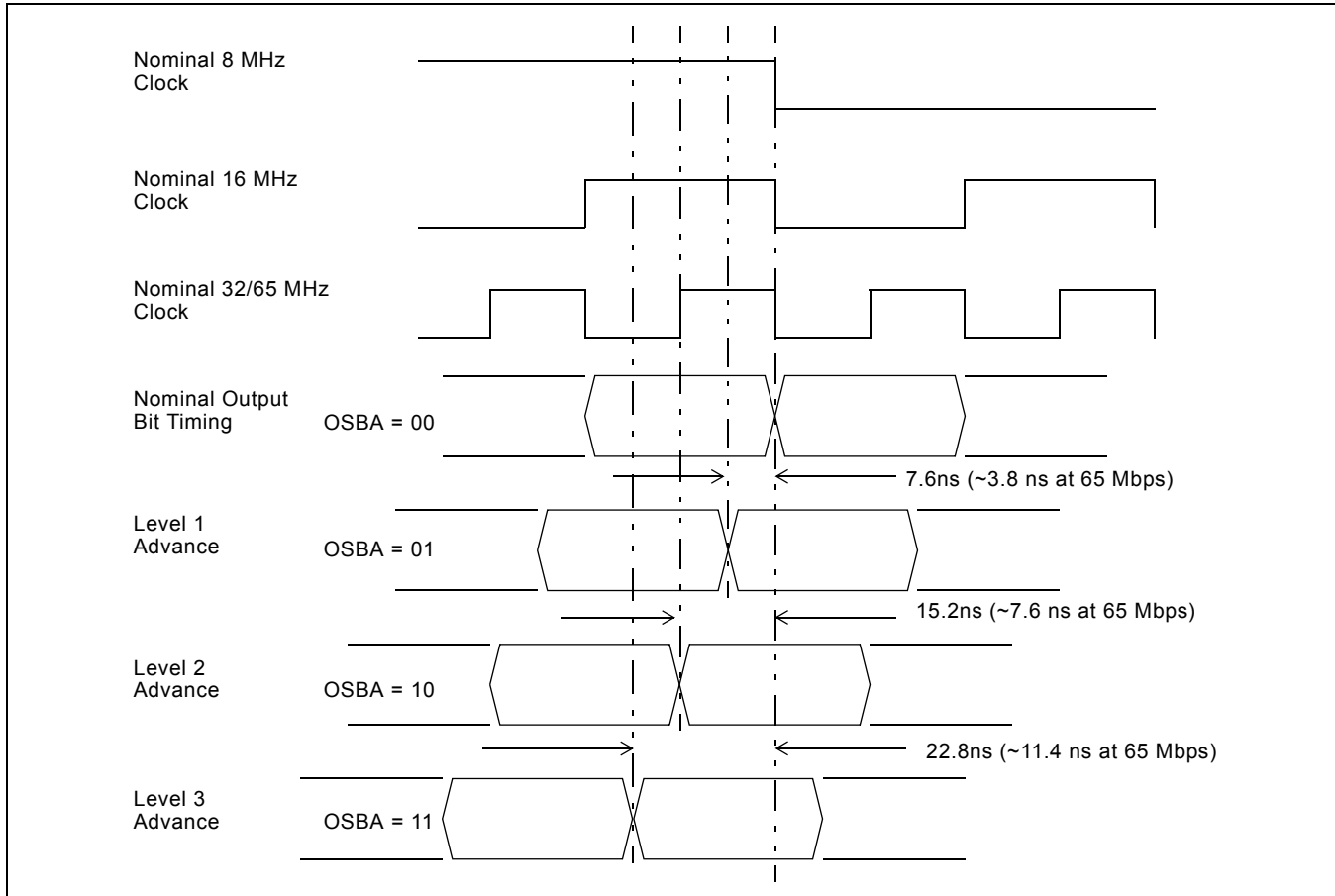

Figure 5 - Output Bit Advancement Timing

This programming feature is provided to assist in designs where per stream routing delays are significant and different.

The OSBA bits in the Group Control Registers are used to set the bit-advancement for each of the corresponding serial output stream groups. Figure 5 illustrates the effect of the OSBA settings on the output timing.

There are limitations when the ZL50075 is programmed to use $\overline{CKi0}$ as the output stream clock source:

- If the selected reference clock frequency is 65 MHz or 32 MHz, the granularity of the advancement is reduced to 1/2 the clock period
- If the selected reference clock frequency is 16 MHz or 8 MHz, bit advancement is not available and the output streams are driven at the nominal times

6.0 Message Mode

In Message Mode (MSG), microprocessor data can be broadcast to the output data streams on a per-channel basis. This feature is useful for transferring control and status information to external circuits or other TDM devices.

For a given output channel, when the corresponding Per Channel Function (bits 31 - 29) in the Connection Memory are set to Message Mode (010), the Connection Memory's lowest data byte (bits 7 - 0) is output in the timeslot. Refer to Section 14.1.1, Connection Memory Bit Functions, for programming details

To increase programming bandwidth, the ZL50075 has separate addressable 32 bit memory locations, called Connection Memory Least Significant Bytes (LSB), which provide direct access to the Connection Memories' Lowest data bytes (bits 7 - 0). Up to four consecutive message mode channels can be set with one Connection Memory LSB access. Refer to Section 14.1.2, Connection Memory LSB, for programming details.

6.1 Data Memory Read

All TDM input channels can be read via the microprocessor port. This feature is useful for receiving control and status information from external circuits or other TDM devices. Each 32 bit Data Memory access enables up to four consecutive input channels to be monitored. The Data Memory field is read only; any attempt to write to this address range will result in a bus error condition signalled back to the host processor. Refer to Section 14.2, Data Memory, for programming details.

The latency of data reads is up to 3 frames, depending on when the input timeslots are sampled.

6.2 Connection Memory Block Programming

See Section 14.7, Block Init Register, and Section 14.8, Block Init Enable Register, for programming details.

This feature allows for fast initialization of the connection memory after power up. When the block programming mode is enabled, the contents of Block Init Register are written to all Connection Memory Bits. This operation completes in one 125 μ s frame. During Connection Memory initialization, all TDM output streams are set to high impedance.

7.0 Data Delay Through the Switching Paths

See Section 14.1.1, Connection Memory Bit Functions, for programming details.

The switching of information from the input serial streams to the output serial streams results in a throughput delay. The device can be programmed to perform timeslot interchange functions with different throughput delay capabilities on a per-channel basis. For voice applications, select variable throughput delay to ensure minimum delay between input and output data. In wideband data application, select constant delay to maintain the frame integrity of the information through the switch. The delay through the device varies according to the type of throughput delay selected by programming the Per Channel Function (bits 31 - 29) in the Connection Memories. When these bits are set to 011, the channel is in variable delay mode. When they are set to 100, the channel is in constant delay mode.

7.1 Constant Delay Mode

In this mode the frame integrity is maintained in all switching configurations. The delay through the switch is 2 frames - Input Channel + Output Channel. This can result in a minimum delay of 1 frame + 1 channel if the last channel of a stream is switched to the first channel of a stream. The maximum delay is 1 channel short of 3 frames delay. This occurs when the first channel of a stream is switched to the last channel of a stream.

The data throughput delay is expressed as a function of ST-BUS/GCI-Bus frames, input channel number (n) and output channel number (m). The data throughput delay (T) is:

$$T = 2 \text{ frames} + (n - m)$$

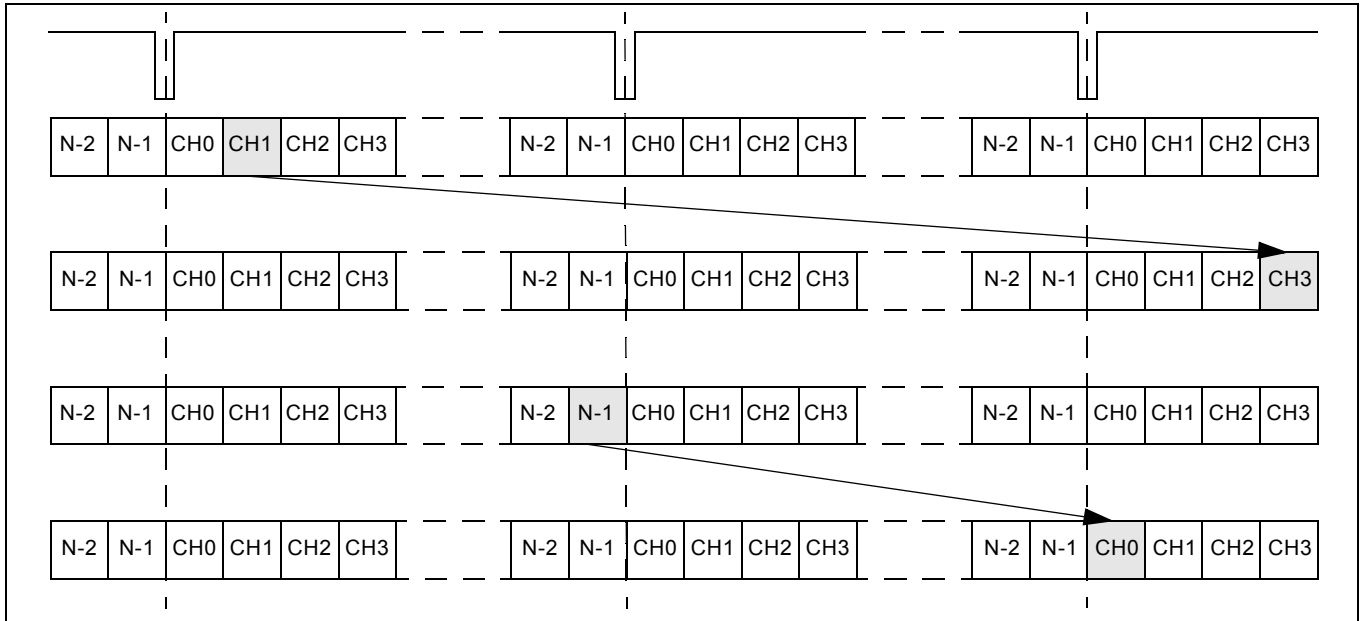

Figure 6 - Data Throughput Delay for Constant Delay

7.2 Variable Delay Mode

Variable delay mode causes the output channel to be transmitted as soon as possible. This is a useful mode for voice applications where the minimum throughput delay is more important than data integrity. The delay through the switch is minimum 3 channels and maximum 1 frame + 2 channels.

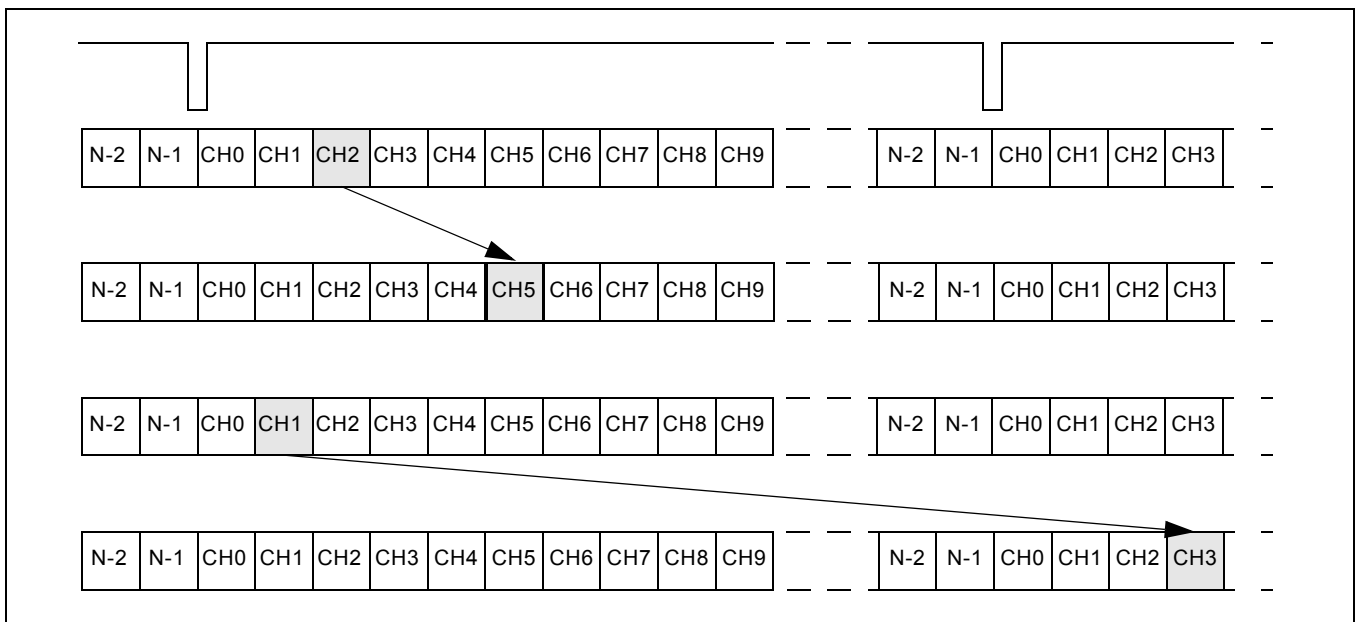

Figure 7 - Data Throughput Delay for Variable Delay

8.0 Per-Channel A-Law/ μ -Law Translation

The ZL50075 provides per channel code translation to be used to adapt pulse code modulation (PCM) voice or data traffic between networks which use different encoding laws. Code translation is available in both Connection Mode and Message Mode.

This feature is controlled by the Connection Memories. The \bar{V}/D (bit 28) defines if the traffic in the channel is voice or data. The ICL1 - 0 (bits 27 - 26) define the input coding law and the OCL1 - 0 (bits 25 - 24) define the output coding law. The different coding options are shown in Table 4:

Input Coding (ICL1 - 0)	Output Coding (OCL1 - 0)	Voice Coding (\bar{V}/D bit = 0)	Data Coding (\bar{V}/D bit = 1)
00	00	ITU-T G.711 A-Law	No Code
01	01	ITU-T G.711 μ -Law	Alternate Bit Inversion (ABI)
10	10	A-Law without Alternate Bit Inversion (ABI)	Inverted Alternate Bit Inversion (ABI)
11	11	μ -Law without Magnitude Inversion (MI)	All Bits Inverted

Table 4 - Input and Output Voice and Data Coding

For voice coding options, the ITU-T G.711 A-Law and ITU-T G.711 μ -Law are the standard rules for encoding. The A-Law without Alternate Bit Inversion (ABI) is an alternative code that does not invert the even bits (6, 4, 2, 0). The μ -Law without Magnitude Inversion (MI) is an alternative code that does not perform Inversion of magnitude bits (6, 5, 4, 3, 2, 1, 0).

When performing data code options, No Code does not invert the bits. The Alternate Bit Inversion (ABI) option inverts the even bits (6, 4, 2, 0) while the Inverted Alternate Bit Inversion (ABI) inverts the odd bits (7, 5, 3, 1). When All Bits Inverted is selected, all of the bits (7, 6, 5, 4, 3, 2, 1, 0) are inverted.

The input channel and output channel encoding law are configured independently. If the output channel coding is set to be different from the input channel, the ZL50075 performs translation between the two standards. If the input and output encoding laws are set to the same standard, no translation occurs.

9.0 Bit Error Rate Tester

The ZL50075 has one Bit Error Rate (BER) transmitter and one BER receiver for each pair of input and output streams, resulting in 64 transmitters connected to the output streams and 64 receivers associated with the input streams. Each transmitter can generate a BER sequence with a pattern of $2^{15}-1$ Pseudo-Random Code (ITU O.151). Each transmitter can start at any location on the stream and will last for a minimum of 1 channel to a maximum of 1 frame time (125 μ s). The BER transmitters are enabled by programming the Per Channel Function (bit 31 - 29) to 101 (PRBS Generator mode) in the Connection Memories.

Multiple Connection Memory locations can be programmed for BER tests. These locations are not required to be consecutive. However, when read back, the BER locations must be received in the same order that they were transmitted. If the BER locations are not received in the same order, the BER test will produce errors.

The PRBS bit pattern is sequentially loaded into the output timeslots. An example is shown in Figure 8.

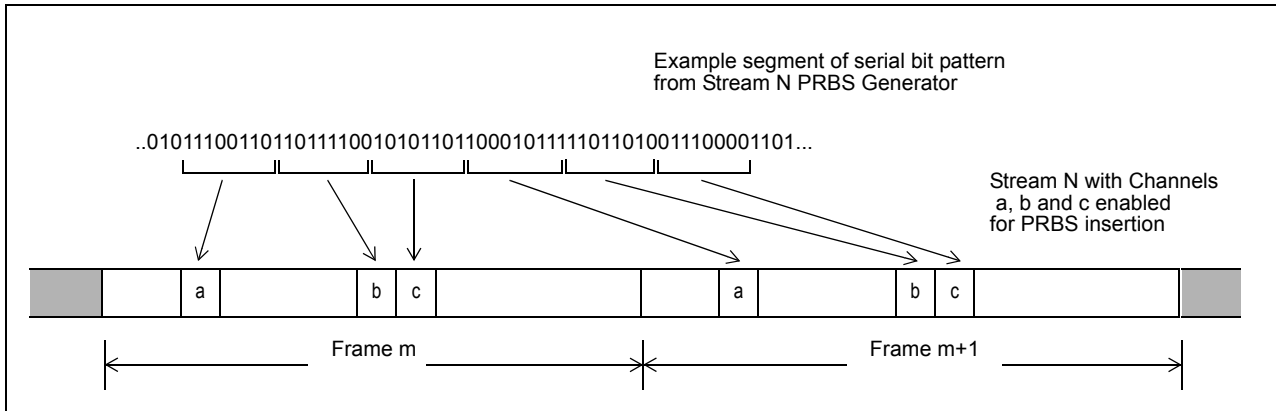

Figure 8 - Example PRBS Timeslot Insertion

Each PRBS detector can be configured to monitor for bit errors in one or more timeslots. The selection of timeslots is configured by the Input BER Enable Control Memory (IBERECM). See Section 14.3.1 for programming details, Each detector has an associated 16 bit error counter accessible via the microprocessor interface, as described in Section 14.3.2, BER Counters. The value of the counter represents the total number of errors detected on the corresponding input stream. Bit errors are accumulated until the counter is either reset (by writing to the counter or by resetting the device), or the counter reaches its maximum value, 65,535 (decimal). If more than 65,535 errors are detected, the counter will hold at the maximum value until reset.

Any number of timeslots may be configured for bit error rate testing; however the user must ensure the following for correct operation of the BER test function:

1. The number of timeslots enabled for PRBS detection on the input stream must equal the number of timeslots enabled for PRBS generation on the source output stream
2. The arrival order of timeslots at the PRBS detector must be the same as the order in which timeslots were transmitted by the PRBS generator. For example, in Figure 8 above, the timeslot order a, b, c must be maintained through the external path from source TDM output stream to destination TDM input stream.

10.0 Microprocessor Port

The ZL50075 has a generic 16-bit microprocessor port that provides access to the 32-bit internal Data Memory (read access only), Connection Memory and Control Registers. D15 on the bus maps to Bit 31 and Bit 15 of the internal 32 bit memory or register, D14 maps to Bit 30 and Bit 14, etc.

The IM pin is used to select between Motorola bus control and Intel bus control. If the IM input is low, then a Motorola control is selected. If the IM bit is high, then an Intel control is selected. Regardless of which bus configuration is selected, the bus cycle termination signals WAIT & DTA are both provided.

The Data Memory, Connection Memory and Control Registers are assigned 32 bit fields in the ZL50075 memory space. Each 32 bit memory or register location spans 4 consecutive addresses. Example:

- The 32 bit Group Control Register for TDM Group 0 is located at address range 40200 - 40203 Hex

The Least Significant address identifies the Most Significant Byte (MSB) in the 32 bit field, as illustrated in Table 5.

Address (Hex)	Memory/Register Bits
40200	Bits 31:24 (MSB)
40201	Bits 23:16
40202	Bits 15:8
40203	Bits 7:0 (LSB)

Table 5 - Example of Address and Byte Significance

The Address Bus, A18 - 0, controls access to each 32 bit location. A0 is not used and must be connected to defined logic level. Address bit A1 and the Data Transfer Size inputs, SIZ1 - 0, identify which bytes are being accessed.

In Motorola Bus Mode (IM = 0), SIZ1 - 0 form active low data strobe signals, consistent with \overline{UDS} and \overline{LDS} available on the MC68000 and MC68302 processors, as shown in Table 6.

In Intel Bus Mode (IM = 1), SIZ1 - 0 form active low byte enable signals, consistent with $\overline{BE1}$ and $\overline{BE0}$ available on the Intel i960 processor, as shown in Table 6.

Pin Name	Motorola Mode MC68000, MC68302 Equivalent Function IM = 0	Intel Mode i960 Equivalent Function IM = 1	Data Bus Bytes Enabled
SIZ1	\overline{UDS}	$\overline{BE1}$	D15-8
SIZ0	\overline{LDS}	$\overline{BE0}$	D7-0

Table 6 - Byte Enable Signals

In both Intel and Motorola modes, the A1 address input is used to identify the word alignment in internal memory, as shown in Table 7.

A1	Memory Data Word Alignment
0	Bits 31:16
1	Bits 15:0

Table 7 - Memory Data Word Alignment

Data bus word alignments are shown in Table 8. An example of byte addressing is given in Table 9.

Microprocessor 16 Bit Data Bus	SIZ1	SIZ0	A1	Internal 32-Bit Memory or Register
D15 - 8	0	1	0	Bits 31:24
	0	1	1	Bits 15:8
D7 - 0	1	0	0	Bits 23:16
	1	0	1	Bits 7:0
D15 - 0	0	0	0	Bits 31:16
	0	0	1	Bits 15:0
	1	1	X ¹	No access

Table 8 - Data Bus Word Alignment

1. X - Don't Care

Address (Hex)	Register Description	Register Byte	A18 - 0 (binary)	SIZ1	SIZ0	Comments
40200 or 40201	Group Control Register (Group 0)	Bits 23:16	100 0000 0010 0000 000X [†]	1	0	8 bit transfer
40282 or 40283	Input Clock Control Register	Bits 15:8	100 0000 0010 1000 001X [†]	0	1	8 bit transfer
40286 or 40287	Output Clock Control Register	Bits 15:0	100 0000 0010 1000 011X [†]	0	0	16 bit transfer
40284 or 40285	Output Clock Control Register	Bits 31:16	100 0000 0010 1000 010X [†]	0	0	16 bit transfer

Table 9 - Byte Address Examples

† - Don't Care. A0 is not used.

10.1 Bus Operation

10.1.1 Read Cycle

The operation of a read cycle is illustrated in Figure 9.

- The microprocessor asserts the $\overline{R/W}$ control signal high, to signal a read cycle. It also drives the address A, transfer size, SIZ1 - 0, and chip select logic drives the \overline{CS} signal active low to select the ZL50075
- The microprocessor then drives the \overline{DS} signal active low, to signal the start of the bus cycle. The \overline{DS} signal is held low for the duration of the bus cycle
- \overline{WAIT} is asserted active low
- The ZL50075 accesses the requested memory or register location(s), and places the requested data onto the data bus, D15 - 0. All data bus pins are driven, whether or not they are being used for the specific data transfer. Unused pins will present unknown data. If the address is to an unused area of the memory space, unknown data is presented on the data bus
- The ZL50075 then de-asserts \overline{WAIT} , and asserts either \overline{DTA} or \overline{BERR} , depending on the validity of the data transfer
- When the microprocessor observes the active low state of the \overline{DTA} or the \overline{BERR} signal or the low-to-high transition of the \overline{WAIT} signal, it terminates the bus cycle by driving the \overline{DS} pin inactive high
- When the ZL50075 sees the \overline{DS} signal go inactive high, it removes the assertions on the \overline{DTA} or \overline{BERR} signals by driving them inactive high
- When the ZL50075 sees the \overline{CS} signal go inactive high, it tri-states the data bus, D15 - 0 and the \overline{DTA} , \overline{BERR} and \overline{WAIT} signals. However, if \overline{CS} goes inactive high before \overline{DS} goes inactive high, the \overline{DTA} , \overline{BERR} and \overline{WAIT} signals are driven inactive high before they are tri-stated
- In Intel mode, \overline{DTA} is always driven to signal the end of a bus cycle, regardless of \overline{BERR}

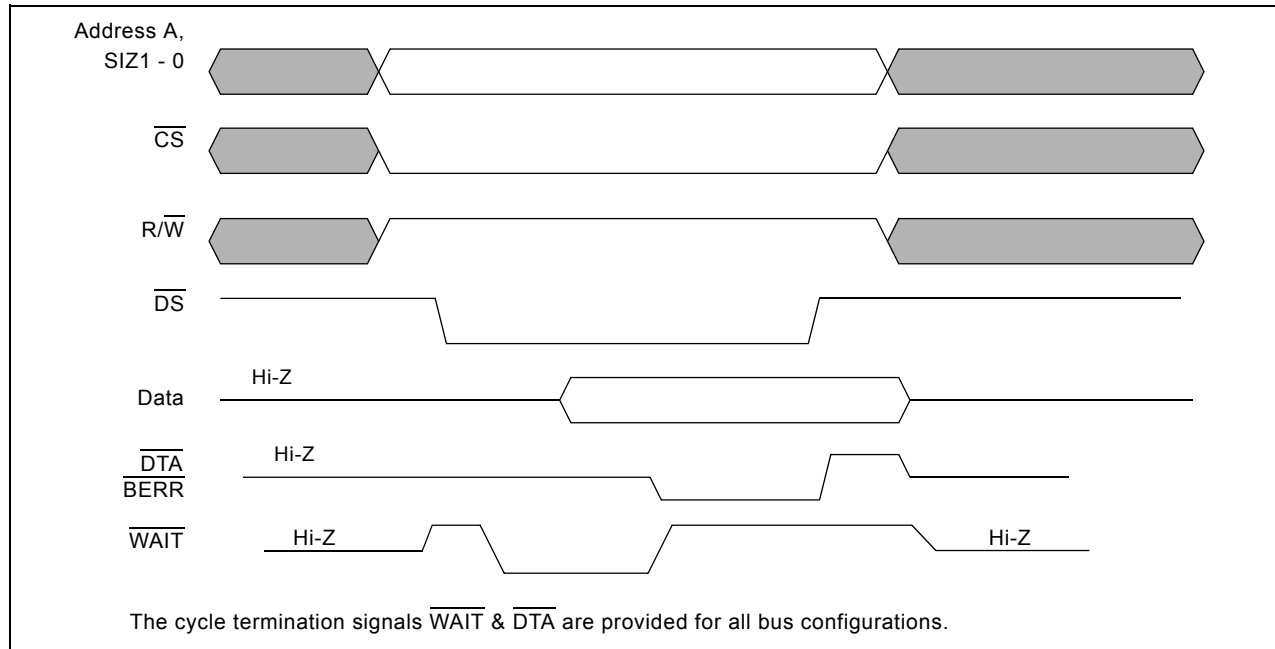

Figure 9 - Read Cycle Operation

10.1.2 Write Cycle

The operation of the write cycle is illustrated in Figure 10.

- The microprocessor asserts the $\overline{\text{R/W}}$ control signal low, to signal a write cycle. It also drives the address A, data transfer size, SIZ1 - 0, and chip select logic drives the $\overline{\text{CS}}$ signal active low to select the ZL50075
- The microprocessor then drives the data bus, D15 - 0 with the data to be written, and then drives the $\overline{\text{DS}}$ signal active low, to signal the start of the bus cycle. The DS signal is held low for the duration of the bus cycle
- $\overline{\text{WAIT}}$ is asserted active low
- The ZL50075 transfers the data presented on the data bus pins into the indicated memory or register location(s). If the address is to an unused area of the memory space, or to the data memory, no data is transferred. The microprocessor port cannot write to the Data Memory
- The ZL50075 then de-asserts $\overline{\text{WAIT}}$, and asserts either $\overline{\text{DTA}}$ or $\overline{\text{BERR}}$, depending on the validity of the data transfer
- When the microprocessor observes the active low state of the $\overline{\text{DTA}}$ or the $\overline{\text{BERR}}$ signal or the low-to-high transition of the $\overline{\text{WAIT}}$ signal, it terminates the bus cycle by driving the $\overline{\text{DS}}$ pin inactive high
- When the ZL50075 sees the $\overline{\text{DS}}$ signal go inactive high, it removes the assertions on the $\overline{\text{DTA}}$ or $\overline{\text{BERR}}$ signals by driving them inactive high
- When the ZL50075 sees the $\overline{\text{CS}}$ signal go inactive high, it tri-states the $\overline{\text{DTA}}$, $\overline{\text{BERR}}$ and $\overline{\text{WAIT}}$ signals. However, if CS goes inactive high before DS goes inactive high, the DTA, BERR and WAIT signals are driven inactive high before they are tri-stated
- In Intel mode, $\overline{\text{DTA}}$ is always driven to signal the end of a bus cycle, regardless of $\overline{\text{BERR}}$

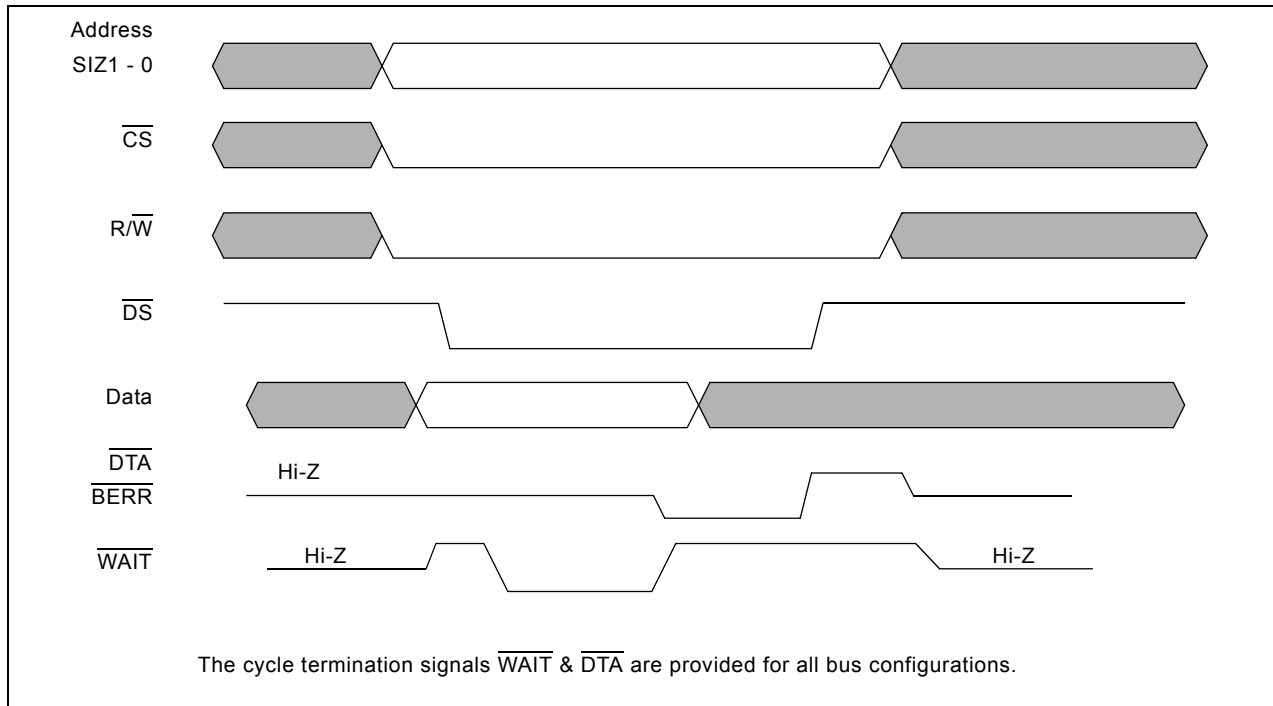

Figure 10 - Write Cycle Operation

11.0 Power-up and Initialization of the ZL50075

11.1 Device Reset and Initialization

The $\overline{\text{PWR}}$ pin is used to reset the ZL50075. When this pin is low, the following functions are performed:

- Asynchronously puts the microprocessor port in a reset state
- Tristates all of the output streams (SToA0 - 31, SToB0 - 31)
- Preloads all of the registers with their default values (refer to the individual registers for default values)
- Clears all internal counters

11.2 Power Supply Sequencing

The ZL50075 has two separate power supplies: $V_{\text{DD_IO}}$ (3.3 V) and $V_{\text{DD_CORE}}$ (1.8 V). The recommended power-up sequence is for $V_{\text{DD_IO}}$ to be applied first, followed by the $V_{\text{DD_CORE}}$ supply. $V_{\text{DD_CORE}}$ should not lead $V_{\text{DD_IO}}$ supply by more than 0.3 V. Both supplies may be powered-down simultaneously.

11.3 Initialization

Upon power up, the ZL50075 should be initialized as follows:

- Assert $\overline{\text{PWR}}$ to low immediately after power is applied
- Set the $\overline{\text{TRST}}$ pin low to disable the JTAG TAP controller
- Deassert the $\overline{\text{PWR}}$ pin.
- Apply the Master Clock Input ($\overline{\text{CKi0}}$) and Master Frame Pulse Input ($\overline{\text{FPi0}}$) to the values defined by the CK_SEL1 - 0 pins
- Set the ODE pin low to disable the output streams

Note: After the $\overline{\text{PWR}}$ reset is removed, and on the application of a suitable master clock input, it takes approximately 1 ms for the internal initialization to complete

- Automatic block initialization of the Connection Memory to all zeros occurs, without microprocessor intervention
- All Group Control Registers are preset to 000C000C hex, corresponding to rates of 65 Mbps, no link inversions, no fractional output bit advancements, internal clock source, and no input sample point delays
- The Input Clock Control Register is preset to 0DB hex, corresponding to:
 - All clock inputs set to negative logic sense
 - All frame pulse inputs set to negative logic sense
 - All input frame pulses set to ST-BUS timing
- The Output Clock Control Register is pre-set to 060D1C3C hex, corresponding to:
 - All clock outputs set to negative logic sense
 - All frame pulse outputs set to negative logic sense
 - All output frame pulses set to ST-BUS timing
 - All output clock source selections to internal
 - Clock outputs, $\overline{\text{CKo0}}$ - 1 are preset to rates of 65 MHz and 32 MHz, respectively

Note: If the master clock input, $\overline{\text{CKi0}}$, is not available, the microprocessor port will assert $\overline{\text{BERR}}$ on all accesses and read cycles.

12.0 IEEE 1149.1 Test Access Port

The JTAG test port is implemented to meet the mandatory requirements of the IEEE 1149.1 (JTAG) standard. The operation of the boundary-scan circuitry is controlled by an external Test Access Port (TAP) Controller.

The ZL50075 uses the public instructions defined in IEEE 1149.1, with the provision of a 16-bit Instruction Register, and three scannable Test Data Registers: Boundary Scan Register, Bypass Register and Device Identification Register.

12.1 Test Access Port (TAP)

The Test Access Port (TAP) accesses the ZL50075 test functions. The interface consists of 4 input and 1 output signal. as follows:

- **Test Clock (TCK)** - TCK provides the clock for the test logic. The TCK does not interfere with any on-chip clock and thus remains independent in the functional mode. The TCK permits shifting of test data into or out of the Boundary-Scan register cells concurrently with the operation of the device and without interfering with the on-chip logic.
- **Test Mode Select (TMS)** - The TAP Controller uses the logic signals received at the TMS input to control test operations. The TMS signals are sampled at the rising edge of the TCK pulse. This pin is internally pulled to $V_{\text{DD_IO}}$ when it is not driven from an external source.
- **Test Data Input (TDi)** - Serial input data applied to this port is fed either into the instruction register or into a test data register, depending on the sequence previously applied to the TMS input. Both registers are described in a subsequent section. The received input data is sampled at the rising edge of TCK pulses. This pin is internally pulled to $V_{\text{DD_IO}}$ when it is not driven from an external source.
- **Test Data Output (TDo)** - Depending on the sequence previously applied to the TMS input, the contents of either the instruction register or data register are serially shifted out towards the TDo. The data out of the TDo is clocked on the falling edge of the TCK pulses. When no data is shifted through the boundary scan cells, the TDo driver is set to a high impedance state.

- **Test Reset ($\overline{\text{TRST}}$)** - Resets the JTAG scan structure. This pin is internally pulled to V_{DD_IO} when it is not driven from an external source. When JTAG is not in use, this pin must be tied low for normal operation.

The TAP signals are only applied when the ZL50075 is required to be in test mode. When in normal, non-test mode, $\overline{\text{TRST}}$ must be connected low to disable the test logic. The remaining test pins may be left unconnected.

12.2 Instruction Register

The ZL50075 uses the public instructions defined in the IEEE 1149.1 standard. The JTAG interface contains a 16-bit instruction register. Instructions are serially loaded into the instruction register from the TDi when the TAP controller is in its shifted-OR state. These instructions are subsequently decoded to achieve two basic functions: to select the test data register that may operate while the instruction is current and to define the serial test data register path that is used to shift data between TDi and TDo during register scanning.

12.3 Test Data Register

As specified in the IEEE 1149.1 standard, the ZL50075 JTAG Interface contains three test data registers:

- **The Boundary-Scan Register** - The Boundary-Scan register consists of a series of Boundary-Scan cells arranged to form a scan path around the boundary of the ZL50075 core logic.
- **The Bypass Register** - The Bypass register is a single stage shift register that provides a one-bit path from TDi to TDo.
- **The Device Identification Register** - The JTAG device ID for the ZL50075 is C39B14B_H

Version	<31:28>	0000
Part Number	<27:12>	1100 0011 1001 1011
Manufacturer ID	<11:1>	0001 0100 101
LSB	<0>	1

12.4 Boundary Scan Description Language (BSDL)

A Boundary Scan Description Language (BSDL) file is available from Zarlink Semiconductor to aid in the use of the IEEE 1149.1 test interface.

13.0 Memory Map of ZL50075

The memory map for the ZL50075 is given in Table 10.

Address (Hex)	Description
00000 - 1FFFF	Connection Memory
20000 - 27FFF	Connection Memory LSB
28000 - 2FFFF	Data Memory: Read only; Bus error on write ($\overline{\text{BERR}}$)
30000 - 37FFF	Input BER Enable Control Memory
38000 - 3FFFF	Invalid Address. Access causes Bus error ($\overline{\text{BERR}}$)
40000 - 401FF	BER Counters
40200 - 4027F	Group Control Registers
40280 - 40283	Input Clock Control Register
40284 - 40287	Output Clock Control Register
40288 - 4028B	Block Init Register
4028C - 4028F	Block Init Enable
40290- 7FFFF	Invalid Address. Access causes Bus error ($\overline{\text{BERR}}$)

Table 10 - Memory Map

14.0 Detailed Memory and Register Descriptions

This section describes all the memories and registers that are used in this device.

14.1 Connection Memory

Address range 00000 - 1FFFF hex.

On power-up, all Connection Memory locations are initialized automatically to 00000000 hex, using the Block Initialization feature, as described in Section 14.7 and Section 14.8.

The 32 bit Connection Memory has 32,768 locations. Each 32 bit long-word is used to program the desired source data and any other per-channel characteristics of one output time-slot.

The memory map for the Connection Memory is sub-divided into 32 blocks, each corresponding to one of the possible 32 output stream group numbers. The address ranges for these blocks are illustrated in Table 11.

Output Group	Start Address (Hex)	Address Range (Hex)	Output Group	Start Address (Hex)	Address Range (Hex)
0	000000	000000 - 000FFF	16	010000	010000 - 010FFF
1	001000	001000 - 001FFF	17	011000	011000 - 011FFF
2	002000	002000 - 002FFF	18	012000	012000 - 012FFF
3	003000	003000 - 003FFF	19	013000	013000 - 013FFF
4	004000	004000 - 004FFF	20	014000	014000 - 014FFF
5	005000	005000 - 005FFF	21	015000	015000 - 015FFF
6	006000	006000 - 006FFF	22	016000	016000 - 016FFF
7	007000	007000 - 007FFF	23	017000	017000 - 017FFF
8	008000	008000 - 008FFF	24	018000	018000 - 018FFF
9	009000	009000 - 009FFF	25	019000	019000 - 019FFF
10	00A000	00A000 - 00AFFF	26	01A000	01A000 - 01AFFF
11	00B000	00B000 - 00BFFF	27	01B000	01B000 - 01BFFF
12	00C000	00C000 - 00CFFF	28	01C000	01C000 - 01CFFF
13	00D000	00D000 - 00DFFF	29	01D000	01D000 - 01DFFF
14	00E000	00E000 - 00EFFF	30	01E000	01E000 - 01EFFF
15	00F000	00F000 - 00FFFF	31	01F000	01F000 - 01FFFF

Table 11 - Connection Memory Group Address Mapping

The mapping of each output stream, $SToAn$ and $SToBn$, depends on the programmed bit rate. The address offset range for each stream is illustrated in Table 12.

Output Group Data Rate	Timeslot Range	Output Stream	Stream Address Offset Range (Hex)
65 Mbps	0 - 1023	$SToAn$	00000 - 00FFF
		$SToBn$	N/A
32 Mbps	0 - 511	$SToAn$	00000 - 007FF
		$SToBn$	00800 - 00FFF
16 Mbps	0 - 255	$SToAn$	00000 - 003FF
		$SToBn$	00400 - 007FF
	N/A	\overline{BERR}	00800 - 00FFF
8 Mbps	0 - 127	$SToAn$	00000 - 001FF
		$SToBn$	00200 - 003FF
	N/A	\overline{BERR}	00400 - 00FFF

Table 12 - Connection Memory Stream Address Offset at Various Output Rates

The address range for a particular stream is given by adding the group start address, as indicated in Table 11, to the appropriate stream offset range, as indicated in Table 12. For example, the Connection Memory address range for SToB12 operating at 32 Mbps is 00C800-00CFFF.

Each output channel timeslot occupies a range of 4 addresses in the Connection Memories. The timeslot address offset is illustrated in Table 13. It shows the maximum number of timeslots that a stream can have, but the actual number of timeslots available depends on the output data rates, as illustrated in Table 1 and Table 12.

Timeslot		Address Offset hex
SToAn	SToBn	
0	0	000
1	1	004
2	2	008
-	-	-
510	510	7F8
511	511	7FC
512		800
513		804
-		-
1021		FF4
1022		FF8
1023		FFC

Table 13 - Connection Memory Timeslot Address Offset Range

14.1.1 Connection Memory Bit Functions

The bit functions of the connection memory are illustrated in Table 14.

External Read/Write Address: 000000 _H Reset Value: 0000 _H															
31	30	29	28	27	26	25	24	23	22	21	20	19	18	17	16
PCF 2	PCF 1	PCF 0	\bar{V}/D	ICL 1	ICL 0	OCL 1	OCL 0	0	0	0	0	0	0	0	0
15	14	13	12	11	10	9	8	7	6	5	4	3	2	1	0
0	GP 4	GP 3	GP 2	GP 1	GP 0	STCH 9	STCH 8	STCH 7	STCH 6	STCH 5	STCH 4	STCH 3	STCH 2	STCH 1	STCH 0

Bit	Name	Description																											
31 - 29	PCF2 - 0	Per Channel Function <table border="1"> <thead> <tr> <th>PCF2 - 0</th><th>Function</th><th>Description</th></tr> </thead> <tbody> <tr> <td>000</td><td>OT</td><td>Output is tri-stated</td></tr> <tr> <td>001</td><td>FH</td><td>Output drives high always</td></tr> <tr> <td>010</td><td>MSG</td><td>Output is in message mode</td></tr> <tr> <td>011</td><td>VAR</td><td>Variable delay connection mode</td></tr> <tr> <td>100</td><td>CD</td><td>Constant delay connection mode</td></tr> <tr> <td>101</td><td>PRBS</td><td>PRBS Generator</td></tr> <tr> <td>110</td><td>OT</td><td>Output is tri-stated</td></tr> <tr> <td>111</td><td>OT</td><td>Output is tri-stated</td></tr> </tbody> </table>	PCF2 - 0	Function	Description	000	OT	Output is tri-stated	001	FH	Output drives high always	010	MSG	Output is in message mode	011	VAR	Variable delay connection mode	100	CD	Constant delay connection mode	101	PRBS	PRBS Generator	110	OT	Output is tri-stated	111	OT	Output is tri-stated
PCF2 - 0	Function	Description																											
000	OT	Output is tri-stated																											
001	FH	Output drives high always																											
010	MSG	Output is in message mode																											
011	VAR	Variable delay connection mode																											
100	CD	Constant delay connection mode																											
101	PRBS	PRBS Generator																											
110	OT	Output is tri-stated																											
111	OT	Output is tri-stated																											
28	\bar{V}/D	Voice/Data Control When this bit is low, the corresponding channel is for voice. When this bit is high, the corresponding channel is for data.																											
27 - 26	ICL1 - 0	Input Coding Law <table border="1"> <thead> <tr> <th rowspan="2">ICL1 - 0</th><th colspan="2">Input Coding Law</th></tr> <tr> <th>For Voice (\bar{V}/D bit = 0)</th><th>For Data (\bar{V}/D bit = 1)</th></tr> </thead> <tbody> <tr> <td>00</td><td>CCITT.ITU A-Law</td><td>No Code</td></tr> <tr> <td>01</td><td>CCITT.ITU μ-Law</td><td>ABI</td></tr> <tr> <td>10</td><td>A-Law w/o ABI</td><td>Inverted ABI</td></tr> <tr> <td>11</td><td>μ-Law w/o Mag. Inv</td><td>All Bits Inverted</td></tr> </tbody> </table>	ICL1 - 0	Input Coding Law		For Voice (\bar{V}/D bit = 0)	For Data (\bar{V}/D bit = 1)	00	CCITT.ITU A-Law	No Code	01	CCITT.ITU μ -Law	ABI	10	A-Law w/o ABI	Inverted ABI	11	μ -Law w/o Mag. Inv	All Bits Inverted										
ICL1 - 0	Input Coding Law																												
	For Voice (\bar{V}/D bit = 0)	For Data (\bar{V}/D bit = 1)																											
00	CCITT.ITU A-Law	No Code																											
01	CCITT.ITU μ -Law	ABI																											
10	A-Law w/o ABI	Inverted ABI																											
11	μ -Law w/o Mag. Inv	All Bits Inverted																											

Table 14 - Connection Memory Bits (CMB)

External Read/Write Address: 000000 _H Reset Value: 0000 _H															
31	30	29	28	27	26	25	24	23	22	21	20	19	18	17	16
PCF 2	PCF 1	PCF 0	\bar{V}/D	ICL 1	ICL 0	OCL 1	OCL 0	0	0	0	0	0	0	0	0
15	14	13	12	11	10	9	8	7	6	5	4	3	2	1	0
0	GP 4	GP 3	GP 2	GP 1	GP 0	STCH 9	STCH 8	STCH 7	STCH 6	STCH 5	STCH 4	STCH 3	STCH 2	STCH 1	STCH 0

Bit	Name	Description																	
25 - 24	OCL1 - 0	Output Coding Law <table border="1" style="margin-left: 20px;"> <thead> <tr> <th rowspan="2">OCL1 - 0</th><th colspan="2">Output Coding Law</th></tr> <tr> <th>For Voice (\bar{V}/D bit = 0)</th><th>For Data (\bar{V}/D bit = 1)</th></tr> </thead> <tbody> <tr> <td>00</td><td>CCITT.ITU A-Law</td><td>No Code</td></tr> <tr> <td>01</td><td>CCITT.ITU μ-Law</td><td>ABI</td></tr> <tr> <td>10</td><td>A-Law w/o ABI</td><td>Inverted ABI</td></tr> <tr> <td>11</td><td>μ-Law w/o Mag. Inv</td><td>All Bits Inverted</td></tr> </tbody> </table>	OCL1 - 0	Output Coding Law		For Voice (\bar{V}/D bit = 0)	For Data (\bar{V}/D bit = 1)	00	CCITT.ITU A-Law	No Code	01	CCITT.ITU μ -Law	ABI	10	A-Law w/o ABI	Inverted ABI	11	μ -Law w/o Mag. Inv	All Bits Inverted
OCL1 - 0	Output Coding Law																		
	For Voice (\bar{V}/D bit = 0)	For Data (\bar{V}/D bit = 1)																	
00	CCITT.ITU A-Law	No Code																	
01	CCITT.ITU μ -Law	ABI																	
10	A-Law w/o ABI	Inverted ABI																	
11	μ -Law w/o Mag. Inv	All Bits Inverted																	
23 - 15	Unused	Reserved. In normal functional mode, these bits MUST be set to zero.																	
14 - 10	GP4 - 0	Source Group Selection. These bits define the input/source group number (31 - 0)																	
9 - 0	STCH 9 - 0	Source Stream and Channel Selection / Message Mode Data In connection mode (constant/variable delay), these bits define the input/source stream and channel number, depending on the data rate. For 65.536 Mbps, bits 9 - 0 select the input channel (0 - 1023). For 32.768 Mbps, bits 9 - 1 select the input channel (0 - 511). Bit 0 selects stream STiA (0) or STiB (1). For 16.869 Mbps, bits 9 - 2 select the input channel (0 - 255). Bit 0 selects stream STiA (0) or STiB (1). Bit 1 MUST be set to 0. For 8.192 Mbps, bits 9 - 3 select the input channel (0 - 127). Bit 0 selects stream STiA (0) or STiB (1). Bit 2-1 MUST be set to 00. In message mode, bits 7 - 0 define the output data. The data is output sequentially with bit 7 being output first. Bits 9 - 8 are not used.																	

Table 14 - Connection Memory Bits (CMB) (continued)

14.1.2 Connection Memory LSB

The Connection Memory Least Significant Byte field is provided to give a convenient alternative way to modify the output data for a stream in message mode. In this memory address range, all of the connection memory least significant bytes (bits 7 - 0) are available for read/write in consecutive address locations. This feature is provided for programming convenience. It can allow higher programming bandwidth on message mode streams. For example, one longword access to this memory space can read or set the message bytes in four consecutive connection memory locations. Access to this memory space is big-endian, with the most significant bytes on the data bus accessing the lower address of the connection memory. Addressing into each of the streams is illustrated in Table 15.

Output Group	Start Address (Hex)	Address Range (Hex)	Output Group	Start Address (Hex)	Address Range (Hex)
0	020000	020000 - 0203FF	16	024000	024000 - 0243FF
1	020400	020400 - 0207FF	17	024400	024400 - 0247FF
2	020800	020800 - 020BFF	18	024800	024800 - 024BFF
3	020C00	020C00 - 020FFF	19	024C00	024C00 - 024FFF
4	021000	021000 - 0213FF	20	025000	025000 - 0253FF
5	021400	021400 - 0217FF	21	025400	025400 - 0257FF
6	021800	021800 - 021BFF	22	025800	025800 - 025BFF
7	021C00	021C00 - 021FFF	23	025C00	025C00 - 025FFF
8	022000	022000 - 0223FF	24	026000	026000 - 0263FF
9	022400	022400 - 0227FF	25	026400	026400 - 0267FF
10	022800	022800 - 022BFF	26	026800	026800 - 026BFF
11	022C00	022C00 - 022FFF	27	026C00	026C00 - 026FFF
12	023000	023000 - 0233FF	28	027000	027000 - 0273FF
13	023400	023400 - 0237FF	29	027400	027400 - 0277FF
14	023800	023800 - 023BFF	30	027800	027800 - 027BFF
15	023C00	023C00 - 023FFF	31	027C00	027C00 - 027FFF

Table 15 - Connection Memory LSB Group Address Mapping

Output Group Data Rate	Timeslot Range	Output Stream	Stream Address Offset Range (Hex)
65 Mbps	0 - 1023	SToAn	00000 - 003FF
		SToBn	N/A
32 Mbps	0 - 511	SToAn	00000 - 001FF
		SToBn	00200 - 003FF
16 Mbps	0 - 255	SToAn	00000 - 000FF
		SToBn	00100 - 001FF
	N/A	$\overline{\text{BERR}}$	00200 - 003FF
8 Mbps	0 - 127	SToAn	00000 - 0007F
		SToBn	00080 - 000FF
	N/A	$\overline{\text{BERR}}$	00100 - 003FF

Table 16 - Connection Memory LSB Stream Address Offset at Various Output Rates

Within each stream group, the mapping of each of the actual output streams, *SToAn* and *SToBn*, depends on the output rate programmed into the Group Control Registers. The address offsets to these control areas for each of the output streams are illustrated in Table 16.

14.2 Data Memory

The data memory field is a read only address range used to monitor the data being received by the input streams. Addressing into each of the streams is illustrated in Table 17.

Input Group	Start Address (Hex)	Address Range (Hex)	Input Group	Start Address (Hex)	Address Range (Hex)
0	028000	028000 - 0283FF	16	02C000	02C000 - 02C3FF
1	028400	028400 - 0287FF	17	02C400	02C400 - 02C7FF
2	028800	028800 - 028BFF	18	02C800	02C800 - 02CBFF
3	028C00	028C00 - 028FFF	19	02CC00	02CC00 - 02CFFF
4	029000	029000 - 0293FF	20	02D000	02D000 - 02D3FF
5	029400	029400 - 0297FF	21	02D400	02D400 - 02D7FF
6	029800	029800 - 029BFF	22	02D800	02D800 - 02DBFF
7	029C00	029C00 - 029FFF	23	02DC00	02DC00 - 02DFFF
8	02A000	02A000 - 02A3FF	24	02E000	02E000 - 02E3FF
9	02A400	02A400 - 02A7FF	25	02E400	02E400 - 02E7FF
10	02A800	02A800 - 02ABFF	26	02E800	02E800 - 02EBFF
11	02AC00	02AC00 - 02AFFF	27	02EC00	02EC00 - 02EFFF
12	02B000	02B000 - 02B3FF	28	02F000	02F000 - 02F3FF
13	02B400	02B400 - 02B7FF	29	02F400	02F400 - 02F7FF
14	02B800	02B800 - 02BBFF	30	02F800	02F800 - 02FBFF
15	02BC00	02BC00 - 02BFFF	31	02FC00	02FC00 - 02FFFF

Table 17 - Data Memory Group Address Mapping

Within each stream group, the mapping of each of the actual input streams, STiAn and STiBn, depends on the input rate programmed into the Group Control Registers. The address offsets to these data areas for each of the input streams are illustrated in Table 18.

Input Group Data Rate	Time-slot Range	Input Streams	Address Offset Range (Hex)
65 Mbps	0 - 1023	STiAn	00000 - 003FF
		STiBn	N/A
32 Mbps	0 - 511	STiAn	00000 - 001FF
		STiBn	00200 - 003FF
16 Mbps	0 - 255	STiAn	00000 - 000FF
		STiBn	00100 - 001FF
	N/A	$\overline{\text{BERR}}$	00200 - 003FF
8 Mbps	0 - 127	STiAn	00000 - 0007F
		STiBn	00080 - 000FF
	N/A	$\overline{\text{BERR}}$	00100 - 003FF

Table 18 - Data Memory Stream Address Offset at Various Output Rates

The address ranges for the data memory portion corresponding to each of the actual input streams, STiAn and STiBn, for any particular input group number is calculated by adding the Start Address for the particular group, as indicated in Table 17, to the appropriate Address Offset Range, as indicated in Table 18. The time-slots map linearly into the appropriate address offset range. (i.e., timeslots 0, 1, 2,... map into addresses 00000, 00001, 00002,...)

The entire data memory is a read only structure. Any write attempts will result in a bus error. $\overline{\text{BERR}}$ is driven active low to terminate the bus cycle.

14.3 BER Control Memory and Error Counters

14.3.1 Input BER Enable Control Memory

The BER Enable Control Memory (IBERECM) is a read/write memory block. Each memory location is used to control the BER counter of one incoming timeslot. Addressing into each of the streams is illustrated in Table 19.

Input Group	Start Address (Hex)	Address Range (Hex)	Input Group	Start Address (Hex)	Address Range (Hex)
0	030000	030000 - 0303FF	16	034000	034000 - 0343FF
1	030400	030400 - 0307FF	17	034400	034400 - 0347FF
2	030800	030800 - 030BFF	18	034800	034800 - 034BFF
3	030C00	030C00 - 030FFF	19	034C00	034C00 - 034FFF
4	031000	031000 - 0313FF	20	035000	035000 - 0353FF
5	031400	031400 - 0317FF	21	035400	035400 - 0357FF
6	031800	031800 - 031BFF	22	035800	035800 - 035BFF
7	031C00	031C00 - 031FFF	23	035C00	035C00 - 035FFF
8	032000	032000 - 0323FF	24	036000	036000 - 0363FF
9	032400	032400 - 0327FF	25	036400	036400 - 0367FF
10	032800	032800 - 032BFF	26	036800	036800 - 036BFF
11	032C00	032C00 - 032FFF	27	036C00	036C00 - 036FFF
12	033000	033000 - 0333FF	28	037000	037000 - 0373FF
13	033400	033400 - 0337FF	29	037400	037400 - 0377FF
14	033800	033800 - 033BFF	30	037800	037800 - 037BFF
15	033C00	033C00 - 033FFF	31	037C00	037C00 - 037FFF

Table 19 - BER Enable Control Memory Group Address Mapping

Each byte location of the BER Enable Memory contains one read/write BER counter enable (BCE) bit, mapped into the D0 location. If the BCE bit is set, then the BER counter for the corresponding stream and timeslot is enabled for the duration of that timeslot. If the BCE bit is cleared the counter is disabled.

Input Group Data Rate	Time-slot Range	Input Streams	Address Offset Range (Hex)
65 Mbps	0 - 1023	STiAn	00000 - 003FF
		STiBn	N/A
32 Mbps	0 - 511	STiAn	00000 - 001FF
		STiBn	00200 - 003FF
16 Mbps	0 - 255	STiAn	00000 - 000FF
		STiBn	00100 - 001FF
	N/A	BERR	00200 - 003FF
8 Mbps	0 - 127	STiAn	00000 - 0007F
		STiBn	00080 - 000FF
	N/A	BERR	00100 - 003FF

Table 20 - BER Enable Control Memory Stream Address Offset at Various Output Rates

14.3.2 BER Counters

There are a total of 64 Bit Error Counters, corresponding to the 64 serial input streams. Each count value is 32 bits wide, but only the least significant 16 bits are used. The most significant 16 bits of the bit error counters will always read back zero. A write operation to any byte of the counter, including the 16 most significant bits, will clear that counter.

Each bit error counter contains the number of single bit errors detected on the corresponding stream, since the counter was last cleared. If the number of bit errors detected exceeds 65535 (decimal), the counter will hold that value until it is cleared.

BER Input Group	BER Input Stream	Start Address (Hex)	End Address (Hex)
0	STiA0	40000	40003
	STiB0	40080	40083
	N/A	BERR - 40100	BERR - 40183
1	STiA1	40004	40007
	STiB1	40084	40087
	N/A	BERR - 40104	BERR - 40187
2	STiA2	40008	4000B
	STiB2	40088	4008B
	N/A	BERR - 40108	BERR - 4018B
.	.	.	.
.	.	.	.
.	.	.	.
31	STiA31	4007C	4007F
	STiB31	400FC	400FF
	N/A	BERR - 4017C	BERR - 401FF

Table 21 - BER Counter Group and Stream Address Mapping

14.4 Group Control Registers

The ZL50075 addresses the issues of a simple programming model and automatic stream configuration by defining a basic switching bit rate of 65.536 Mbps and by grouping the I/O streams. Each TDM I/O group contains 2 input and 2 output streams. The 2 input streams in the same group have identical input characteristics, and similarly, the 2 output streams in the same group have identical output characteristics. However, input and output streams in the same group can have different input and output operation characteristics.

The Group Control Registers are provided for setting the operating characteristics of the TDM input and output streams. All of the Group Control Registers are mapped long-word aligned on 32 bit boundaries in the memory space. Each of the 32 registers is used to control one group. The mapping of the Group Control Registers to the I/O group numbers is illustrated in Table 22. The bit functions of each of the Group Control Registers are illustrated in Table 23.

TDM Group	Group Control Register Address (Hex)
0	40200 - 40203
1	40204 - 40207
2	40208 - 4020B
3	4020C - 4020F
:	:
:	:
29	40274 - 40277
30	40278 - 4027B
31	4027C - 4027F

Table 22 - Group Control Register Addressing

External Read/Write Address: 40200 _H - 4027F _H Reset Value: 000C000C _H															
31	30	29	28	27	26	25	24	23	22	21	20	19	18	17	16
0	0	0	0	0	0	0	0	0	OSI	OSBA 1	OSBA 0	OSBR 1	OSBR 0	OSSRC 1	OSSRC 0
15	14	13	12	11	10	9	8	7	6	5	4	3	2	1	0
0	0	0	0	0	0	ISI	ISPD 4	ISPD 3	ISPD 2	ISPD 1	ISPD 0	ISBR 1	ISBR 0	ISSRC 1	ISSRC 0
Bit	Name	Description													
31 - 23	Unused	Reserved. In normal functional mode, these bits MUST be set to zero.													
22	OSI	Output Stream Inversion For normal operation, this bit is set low. To invert the output stream, set this bit high.													

Table 23 - Group Control Register

External Read/Write Address: 40200 _H - 4027F _H Reset Value: 000C000C _H															
31	30	29	28	27	26	25	24	23	22	21	20	19	18	17	16
0	0	0	0	0	0	0	0	0	OSI	OSBA 1	OSBA 0	OSBR 1	OSBR 0	OSSRC 1	OSSRC 0
15	14	13	12	11	10	9	8	7	6	5	4	3	2	1	0
0	0	0	0	0	0	ISI	ISPD 4	ISPD 3	ISPD 2	ISPD 1	ISPD 0	ISBR 1	ISBR 0	ISSRC 1	ISSRC 0

Bit	Name	Description																	
21 - 20	OSBA1 - 0	Output Stream Bit Advancement <table border="1"> <thead> <tr> <th>OSBA1 - 0</th><th>Non-65 Mbps</th><th>65 Mbps</th></tr> </thead> <tbody> <tr> <td>00</td><td>0 ns</td><td>0 ns</td></tr> <tr> <td>01</td><td>7.6 ns</td><td>3.8 ns</td></tr> <tr> <td>10</td><td>15.2 ns</td><td>7.6 ns</td></tr> <tr> <td>11</td><td>22.8 ns</td><td>11.4 ns</td></tr> </tbody> </table>	OSBA1 - 0	Non-65 Mbps	65 Mbps	00	0 ns	0 ns	01	7.6 ns	3.8 ns	10	15.2 ns	7.6 ns	11	22.8 ns	11.4 ns		
OSBA1 - 0	Non-65 Mbps	65 Mbps																	
00	0 ns	0 ns																	
01	7.6 ns	3.8 ns																	
10	15.2 ns	7.6 ns																	
11	22.8 ns	11.4 ns																	
19 - 18	OSBR1 - 0	Output Stream Bit Rate <table border="1"> <thead> <tr> <th rowspan="2">OSBR1 - 0</th><th colspan="2">Bit Rates Per Group</th></tr> <tr> <th>SToA</th><th>SToB</th></tr> </thead> <tbody> <tr> <td>00</td><td>8.192 Mbps</td><td>8.192 Mbps</td></tr> <tr> <td>01</td><td>16.384 Mbps</td><td>16.384 Mbps</td></tr> <tr> <td>10</td><td>32.768 Mbps</td><td>32.768 Mbps</td></tr> <tr> <td>11</td><td>65.536 Mbps</td><td>Not Used</td></tr> </tbody> </table> <p>Unused streams are tri-stated. If the internal system clock is used as the clock source, all the above data rates are available. Otherwise, the data rate cannot exceed the selected clock source's rate.</p>	OSBR1 - 0	Bit Rates Per Group		SToA	SToB	00	8.192 Mbps	8.192 Mbps	01	16.384 Mbps	16.384 Mbps	10	32.768 Mbps	32.768 Mbps	11	65.536 Mbps	Not Used
OSBR1 - 0	Bit Rates Per Group																		
	SToA	SToB																	
00	8.192 Mbps	8.192 Mbps																	
01	16.384 Mbps	16.384 Mbps																	
10	32.768 Mbps	32.768 Mbps																	
11	65.536 Mbps	Not Used																	
17 - 16	OSSRC1 - 0	Output Stream Clock Source Select <table border="1"> <thead> <tr> <th>OSSRC1 - 0</th><th>Output Timing Source</th></tr> </thead> <tbody> <tr> <td>00</td><td>Internal System Clock</td></tr> <tr> <td>01</td><td>$\overline{\text{CKi0}}$ and $\overline{\text{FPi0}}$</td></tr> <tr> <td>10</td><td>Reserved</td></tr> <tr> <td>11</td><td>Reserved</td></tr> </tbody> </table>	OSSRC1 - 0	Output Timing Source	00	Internal System Clock	01	$\overline{\text{CKi0}}$ and $\overline{\text{FPi0}}$	10	Reserved	11	Reserved							
OSSRC1 - 0	Output Timing Source																		
00	Internal System Clock																		
01	$\overline{\text{CKi0}}$ and $\overline{\text{FPi0}}$																		
10	Reserved																		
11	Reserved																		
15 - 10	Unused	Reserved. In normal functional mode, these bits MUST be set to zero.																	
9	ISI	Input Stream Inversion For normal operation, this bit is set low. To invert the input stream, set this bit high.																	
8 - 4	ISPD4 - 0	Input Sampling Point Delay Default Sampling Point is 3/4. Adjust according to Figure on page 18.																	

Table 23 - Group Control Register (continued)

External Read/Write Address: 40200 _H - 4027F _H Reset Value: 000C000C _H															
31	30	29	28	27	26	25	24	23	22	21	20	19	18	17	16
0	0	0	0	0	0	0	0	0	OSI	OSBA 1	OSBA 0	OSBR 1	OSBR 0	OSSRC 1	OSSRC 0
15	14	13	12	11	10	9	8	7	6	5	4	3	2	1	0
0	0	0	0	0	0	ISI	ISPD 4	ISPD 3	ISPD 2	ISPD 1	ISPD 0	ISBR 1	ISBR 0	ISSRC 1	ISSRC 0

Bit	Name	Description																	
3 - 2	ISBR1 - 0	Input Stream Bit Rate <table border="1"> <thead> <tr> <th rowspan="2">ISBR1 - 0</th><th colspan="2">Bit Rates Per Group</th></tr> <tr> <th>STiA</th><th>STiB</th></tr> </thead> <tbody> <tr> <td>00</td><td>8.192 Mbps</td><td>8.192 Mbps</td></tr> <tr> <td>01</td><td>16.384 Mbps</td><td>16.384 Mbps</td></tr> <tr> <td>10</td><td>32.768 Mbps</td><td>32.768 Mbps</td></tr> <tr> <td>11</td><td>65.536 Mbps</td><td>Not Used</td></tr> </tbody> </table> <p>Unused streams must be connected to ground. If the internal system clock is used as the clock source, all the above data rates are available. Otherwise, the data rate cannot exceed the selected clock source's rate.</p>	ISBR1 - 0	Bit Rates Per Group		STiA	STiB	00	8.192 Mbps	8.192 Mbps	01	16.384 Mbps	16.384 Mbps	10	32.768 Mbps	32.768 Mbps	11	65.536 Mbps	Not Used
ISBR1 - 0	Bit Rates Per Group																		
	STiA	STiB																	
00	8.192 Mbps	8.192 Mbps																	
01	16.384 Mbps	16.384 Mbps																	
10	32.768 Mbps	32.768 Mbps																	
11	65.536 Mbps	Not Used																	
1 - 0	ISSRC1 - 0	Input Stream Clock Source Select <table border="1"> <thead> <tr> <th>ISSRC1 - 0</th><th>Input Timing Source</th></tr> </thead> <tbody> <tr> <td>00</td><td>Internal System Clock</td></tr> <tr> <td>01</td><td>$\overline{CKi0}$ and $\overline{FPi0}$</td></tr> <tr> <td>10</td><td>Reserved</td></tr> <tr> <td>11</td><td>Reserved</td></tr> </tbody> </table>	ISSRC1 - 0	Input Timing Source	00	Internal System Clock	01	$\overline{CKi0}$ and $\overline{FPi0}$	10	Reserved	11	Reserved							
ISSRC1 - 0	Input Timing Source																		
00	Internal System Clock																		
01	$\overline{CKi0}$ and $\overline{FPi0}$																		
10	Reserved																		
11	Reserved																		

Table 23 - Group Control Register (continued)

The Group Control Register is a static control register. Changes to bit settings may disrupt data flow on the selected port for a maximum of 2 frames.

14.5 Input Clock Control Register

The Input Clock Control Register is used to select the logic sense of the input clock.

External Read/Write Address: 40280 _H Reset Value: 0DB _H															
31	30	29	28	27	26	25	24	23	22	21	20	19	18	17	16
0	0	0	0	0	0	0	0	0	0	0	0	0	0	0	0
15	14	13	12	11	10	9	8	7	6	5	4	3	2	1	0
0	0	0	0	0	0	0	0	1	1	0	1	1	GCI SEL0	FPI POLO	CKI POLO
Bit	Name	Description													
31 - 9	Unused	Reserved. In normal functional mode, these bits MUST be set to zero.													
8 - 3	Unused	Reserved. In normal functional mode, these bits MUST be set to 011011.													
2	GCISEL0	GCI-Bus Selection for $\overline{\text{FPI0}}$ When this bit is low, $\overline{\text{FPI0}}$ is set for ST-BUS mode. When this bit is high, $\overline{\text{FPI0}}$ is set for GCI-Bus mode.													
1	FPIPOLO	Frame Pulse Polarity Selection for $\overline{\text{FPI0}}$ When this bit is low, $\overline{\text{FPI0}}$ is set for active high. When this bit is high, $\overline{\text{FPI0}}$ is set for active low.													
0	CKIPOLO	Clock Polarity Selection for $\overline{\text{CKi0}}$ When this bit is low, $\overline{\text{CKi0}}$ is set for the positive clock edge. When this bit is high, $\overline{\text{CKi0}}$ is set for the negative clock edge.													

Table 24 - Input Clock Control Register

14.6 Output Clock Control Register

The Output Clock Control Register is used to select the desired source, frequency, and logic sense of the output clocks. The bit functions of the Output Clock Control Register are illustrated in Table 25.

External Read/Write Address: 40284 _H Reset Value: 060D1C3C _H																														
31	30	29	28	27	26	25	24	23	22	21	20	19	18	17	16															
0	0	0	0	0	1	1	0	0	0	0	0	1	1	0	1															
15	14	13	12	11	10	9	8	7	6	5	4	3	2	1	0															
0	0	GCO SEL1	FPO POL1	CKO POL1	CKO1 RATE1	CKO1 RATE0	CKO1 SRC1	CKO1 SRC0	GCO SEL0	FPO POL0	CKO POL0	CKO0 RATE1	CKO0 RATE0	CKO0 SRC1	CKO0 SRC0															
Bit	Name	Description																												
31 - 28	Unused	Reserved. In normal functional mode, these bits MUST be set to zero.																												
27 - 14	Unused	Reserved. In normal functional mode, these bits MUST be set to 01100000110100.																												
13	GCO SEL1	GCI-Bus Selection for $\overline{\text{FPo1}}$ When this bit is low, $\overline{\text{FPo1}}$ is set for ST-BUS mode. When this bit is high, $\overline{\text{FPo1}}$ is set for GCI-Bus mode.																												
12	FPO POL1	Frame Pulse Polarity Selection for $\overline{\text{FPo1}}$ When this bit is low, $\overline{\text{FPo1}}$ is set for active high. When this bit is high, $\overline{\text{FPo1}}$ is set for active low.																												
11	CKO POL1	Clock Polarity Selection for $\overline{\text{CKo1}}$ When this bit is low, $\overline{\text{CKo1}}$ is set for the positive clock edge. When this bit is high, $\overline{\text{CKo1}}$ is set for the negative clock edge.																												
10 - 9	CKO1 RATE 1 - 0	Output Clock Rate for $\overline{\text{CKo1}}$ and $\overline{\text{FPo1}}$ The output clock rate can not exceed the selected clock source rate. All rates are available when the internal system clock is selected as clock source.																												
		<table border="1"> <thead> <tr> <th>CKO1RATE1 - 0</th><th>$\overline{\text{CKo1}}$</th><th>$\overline{\text{FPo1}}$</th></tr> </thead> <tbody> <tr> <td>00</td><td>8.192 MHz</td><td>120 ns</td></tr> <tr> <td>01</td><td>16.384 MHz</td><td>60 ns</td></tr> <tr> <td>10</td><td>32.768 MHz</td><td>30 ns</td></tr> <tr> <td>11</td><td>65.536 MHz</td><td>15 ns</td></tr> </tbody> </table>														CKO1RATE1 - 0	$\overline{\text{CKo1}}$	$\overline{\text{FPo1}}$	00	8.192 MHz	120 ns	01	16.384 MHz	60 ns	10	32.768 MHz	30 ns	11	65.536 MHz	15 ns
CKO1RATE1 - 0	$\overline{\text{CKo1}}$	$\overline{\text{FPo1}}$																												
00	8.192 MHz	120 ns																												
01	16.384 MHz	60 ns																												
10	32.768 MHz	30 ns																												
11	65.536 MHz	15 ns																												
8 - 7	CKO1 SRC 1 - 0	Output Clock Source for $\overline{\text{CKo1}}$ and $\overline{\text{FPo1}}$																												
		<table border="1"> <thead> <tr> <th>CKO1SRC1 - 0</th><th>Output Timing Source</th></tr> </thead> <tbody> <tr> <td>00</td><td>Internal System Clock</td></tr> <tr> <td>01</td><td>$\overline{\text{CKi0}}$ and $\overline{\text{FPi0}}$</td></tr> <tr> <td>10</td><td>Reserved</td></tr> <tr> <td>11</td><td>Reserved</td></tr> </tbody> </table>														CKO1SRC1 - 0	Output Timing Source	00	Internal System Clock	01	$\overline{\text{CKi0}}$ and $\overline{\text{FPi0}}$	10	Reserved	11	Reserved					
CKO1SRC1 - 0	Output Timing Source																													
00	Internal System Clock																													
01	$\overline{\text{CKi0}}$ and $\overline{\text{FPi0}}$																													
10	Reserved																													
11	Reserved																													

Table 25 - Output Clock Control Register

External Read/Write Address: 40284 _H Reset Value: 060D1C3C _H																															
31	30	29	28	27	26	25	24	23	22	21	20	19	18	17	16																
0	0	0	0	0	1	1	0	0	0	0	0	1	1	0	1																
15	14	13	12	11	10	9	8	7	6	5	4	3	2	1	0																
0	0	GCO SEL1	FPO POL1	CKO POL1	CKO1 RATE1	CKO1 RATE0	CKO1 SRC1	CKO1 SRC0	GCO SEL0	FPO POL0	CKO POL0	CKO0 RATE1	CKO0 RATE0	CKO0 SRC1	CKO0 SRC0																
Bit	Name	Description																													
6	GCO SEL0	GCI-Bus Selection for $\overline{\text{FPo0}}$ When this bit is low, $\overline{\text{FPo0}}$ is set for ST-BUS mode. When this bit is high, $\overline{\text{FPo0}}$ is set for GCI-Bus mode.																													
5	FPO POL0	Frame Pulse Polarity Selection for $\overline{\text{FPo0}}$ When this bit is low, $\overline{\text{FPo0}}$ is set for active high. When this bit is high, $\overline{\text{FPo0}}$ is set for active low.																													
4	CKO POL0	Clock Polarity Selection for $\overline{\text{CKo0}}$ When this bit is low, $\overline{\text{CKo0}}$ is set for the positive clock edge. When this bit is high, $\overline{\text{CKo0}}$ is set for the negative clock edge.																													
3 - 2	CKO0 RATE 1 - 0	Output Clock Rate for $\overline{\text{CKo0}}$ and $\overline{\text{FPo0}}$ The output clock rate can not exceed the selected clock source rate. All rates are available when the internal system clock is selected as clock source.																													
		<table border="1"> <thead> <tr> <th>CKO0RATE1 - 0</th><th>$\overline{\text{CKo0}}$</th><th>$\overline{\text{FPo0}}$</th></tr> </thead> <tbody> <tr> <td>00</td><td>8.192 MHz</td><td>120 ns</td></tr> <tr> <td>01</td><td>16.384 MHz</td><td>60 ns</td></tr> <tr> <td>10</td><td>32.768 MHz</td><td>30 ns</td></tr> <tr> <td>11</td><td>65.536 MHz</td><td>15 ns</td></tr> </tbody> </table>															CKO0RATE1 - 0	$\overline{\text{CKo0}}$	$\overline{\text{FPo0}}$	00	8.192 MHz	120 ns	01	16.384 MHz	60 ns	10	32.768 MHz	30 ns	11	65.536 MHz	15 ns
CKO0RATE1 - 0	$\overline{\text{CKo0}}$	$\overline{\text{FPo0}}$																													
00	8.192 MHz	120 ns																													
01	16.384 MHz	60 ns																													
10	32.768 MHz	30 ns																													
11	65.536 MHz	15 ns																													
1 - 0	CKO0 SRC 1 - 0	Output Clock Source for $\overline{\text{CKo0}}$ and $\overline{\text{FPo0}}$																													
		<table border="1"> <thead> <tr> <th>CKO0SRC1 - 0</th><th>Output Timing Source</th></tr> </thead> <tbody> <tr> <td>00</td><td>Internal System Clock</td></tr> <tr> <td>01</td><td>$\overline{\text{CKi0}}$ and $\overline{\text{FPi0}}$</td></tr> <tr> <td>10</td><td>Reserved</td></tr> <tr> <td>11</td><td>Reserved</td></tr> </tbody> </table>															CKO0SRC1 - 0	Output Timing Source	00	Internal System Clock	01	$\overline{\text{CKi0}}$ and $\overline{\text{FPi0}}$	10	Reserved	11	Reserved					
CKO0SRC1 - 0	Output Timing Source																														
00	Internal System Clock																														
01	$\overline{\text{CKi0}}$ and $\overline{\text{FPi0}}$																														
10	Reserved																														
11	Reserved																														

Table 25 - Output Clock Control Register (continued)

14.7 Block Init Register

The Block Init Register is a 32 bit read/write register at address 040288 - 04028B_H.

The Block Init Register is used during block initialization of the connection memory. A block initialization automatically occurs at power-up. However, it is possible to perform a block initialization at any time. During Block Initialization, the value of the Block Init Register is copied to all connection memory locations in an operation that runs in about 120 μ s. If the Block Init Register is modified during a block initialization, the new value used is ignored.

14.8 Block Init Enable Register

The Block Init Enable Register is a 32 bit read/write register at address 04028C - 04028F_H.

The Block Init Enable Register is used to initiate a block initialization of the connection memory. A block initialization automatically occurs at power-up. Since the Block Init Register is cleared at power-up this automatic block initialization will write all zeros to all Connection Memory Bits. However, it is possible to perform a block initialization at any time. To begin a block initialization, the hex value 31415926 must be written to the Block Init Enable Register. If a block initialization is signaled while one is in progress, the signal is ignored, and the currently active block initialization is allowed to complete.

The value read back from the Block Init Enable Register is different from the value written. It represents both the block initialization status, and the power-up reset initialization status. The meaning of the initialization status bits is illustrated in Table 26. The bits 31 - 2 always read back 0.

Bit	Name	Description
0	Block Init Status	0 if Block initialization is completed; 1 if Block initialization is in progress
1	Reset Init Status	0 if Reset initialization is completed 1 if Reset initialization is in progress

Table 26 - Block and Power-up Initialization Status Bits

Any access to the connection memory or the data memory during a block initialization or a reset initialization will result in a bus error, BERR. All TDM outputs are tri-stated during any block initialization.

15.0 DC/AC Electrical Characteristics

Absolute Maximum Ratings¹ - Voltages are with respect to ground (V_{SS}) unless otherwise stated.

	Characteristics	Sym.	Min.	Typ. ²	Max.	Unit
1	Chip I/O Supply Voltage	V_{DD_IO}	-0.5		5.0	V
2	Chip Core Supply Voltage	V_{DD_CORE}	-0.5		5.0	V
3	Input Voltage (non-5 V tolerant inputs)	V_{I_3V}	-0.5		$V_{DD_IO} + 0.5$	V
4	Input Voltage (5 V tolerant inputs)	V_{I_5V}	-0.5		7.0	V
5	Continuous Current at digital outputs	I_o			15	mA
6	Package power dissipation	P_D			2.1	W
7	Storage temperature	T_S	- 55		+125	°C

Note 1: Exceeding these values may cause permanent damage. Functional operation under these conditions is not implied.

Note 2: Typical figures are at 25°C, V_{DD_CORE} at 1.8 V and V_{DD_IO} at 3.3 V and are for design aid only: not guaranteed and not subject to production testing.

Recommended Operating Conditions - Voltages are with respect to ground (V_{SS}) unless otherwise stated.

	Characteristics	Sym.	Min.	Typ. ¹	Max.	Unit
1	Operating Temperature	T_{OP}	-40	25	+85	°C
2	Positive Supply Core	V_{DD_CORE}	1.71	1.8	1.89	V
3	Positive Supply I/O	V_{DD_IO}	3.0	3.3	3.6	V
4	Input Voltage (non-5 V tolerant inputs)	V_{I_3V}	0		V_{DD_IO}	V
5	Input Voltage (5 V tolerant inputs)	V_{I_5V}	0		5.5	

Note 1: Typical figures are at 25°C, V_{DD_CORE} at 1.8 V and V_{DD_IO} at 3.3 V and are for design aid only: not guaranteed and not subject to production testing.

DC Electrical Characteristics - Voltages are with respect to ground (VSS) unless otherwise stated.

	Characteristics	Sym.	Min.	Typ. ¹	Max.	Unit	Test Conditions
1	Core Supply Current ²	I_{DD_CORE}			500	mA	
2	I/O Supply Current	I_{DD_IO}			62	mA	Outputs Unloaded
3	Leakage Current	I_{DDQ}		105		μ A	
4	Dynamic Power Dissipation	P_{DD}			1.2	W	Outputs Unloaded
5	Input High Voltage	V_{IH}	2.0			V	
6	Input Low Voltage	V_{IL}			0.8	V	
7	Input Leakage-input pins ³	I_{IL}			5	μ A	$0 \leq V_I \leq V_{DD_IO}$
8	Input Leakage-bidirectional pins	I_{BL}			5	μ A	$0 \leq V_I \leq V_{DD_IO}$
9	Pull-up Current	I_{PU}		-33		μ A	Input at 0 V
10	Pull-down Current	I_{PD}		33		μ A	Input at V_{DD_IO}
11	Input Pin Capacitance	C_I		3		pF	
12	Output High Voltage	V_{OH}	2.4			V	$I_{OH} = 8$ mA
13	Output Low Voltage	V_{OL}			0.4	V	$I_{OL} = 8$ mA

Note 1: Typical figures are at 25°C, V_{DD_CORE} at 1.8 V and V_{DD_IO} at 3.3 V and are for design aid only: not guaranteed and not subject to production testing.

Note 2: StoA = 65 Mbps with random patterns. CKo0 = 65 MHz, CKo1 = 32 MHz.

Note 3: Maximum leakage on pins (output or I/O pins in high impedance state) is over an applied voltage (V_{in}).

AC Electrical Characteristics¹ - Timing Parameter Measurement Voltage Levels - Voltages are with respect to ground (V_{SS}) unless otherwise stated.

	Characteristics	Sym.	Level	Unit	Test Conditions
1	CMOS Threshold	V_{CT}	$0.5 V_{DD_IO}$	V	
2	Rise/Fall Threshold Voltage High	V_{HM}	$0.7 V_{DD_IO}$	V	
3	Rise/Fall Threshold Voltage Low	V_{LM}	$0.3 V_{DD_IO}$	V	

1. Characteristics are over recommended operating conditions unless otherwise stated.

AC Electrical Characteristics¹ - $\overline{\text{FPI0}}$ and $\overline{\text{CKi0}}$ Timing

No.	Characteristic (Figure 11)	Sym.	Min.	Typ. ²	Max.	Units	Notes
1	$\overline{\text{FPI0}}$ Input Frame Pulse Setup Time	t_{FPIs}	3		12	ns	$\overline{\text{CKi0}}$ = 65.536 MHz
			3		25	ns	$\overline{\text{CKi0}}$ = 32.768 MHz
			3		55	ns	$\overline{\text{CKi0}}$ = 16.384 MHz
			3		115	ns	$\overline{\text{CKi0}}$ = 8.192 MHz
2	$\overline{\text{FPI0}}$ Input Frame Pulse Hold Time	t_{FPIH}	2		12	ns	$\overline{\text{CKi0}}$ = 65.536 MHz
			2		25	ns	$\overline{\text{CKi0}}$ = 32.768 MHz
			2		55	ns	$\overline{\text{CKi0}}$ = 16.384 MHz
			2		115	ns	$\overline{\text{CKi0}}$ = 8.192 MHz
3	$\overline{\text{FPI0}}$ Input Frame Pulse width	t_{FPIW}	5		24	ns	$\overline{\text{CKi0}}$ = 65.536 MHz
			5		50	ns	$\overline{\text{CKi0}}$ = 32.768 MHz
			5		110	ns	$\overline{\text{CKi0}}$ = 16.384 MHz
			5		230	ns	$\overline{\text{CKi0}}$ = 8.192 MHz
4	$\overline{\text{CKi0}}$ Input Clock Period (average value, does not consider the effects of jitter)	t_{CKIP}	15	15.26	15.5	ns	65.536 MHz
			30	30.5	31	ns	32.768 MHz
			60	61.0	62	ns	16.384 MHz
			120	122	124	ns	8.192 MHz
5	$\overline{\text{CKi0}}$ Input Clock High Time	t_{CKIH}	4			ns	
6	$\overline{\text{CKi0}}$ Input Clock Low Time	t_{CKIL}	4			ns	
7	$\overline{\text{CKi0}}$ Input Clock Rise/Fall Time	t_{rCKI} , t_{fCKI}	0		6	ns	
8	$\overline{\text{CKi0}}$ Input Clock Cycle to Cycle Variation	t_{CVC}			2	ns p-p	Standard rating ³ . STi at 65 Mbps
					4	ns p-p	Standard rating ³ . STi at 32 Mbps
					10	ns p-p	Standard rating ³ . STi at 16 Mbps
					20	ns p-p	Standard rating ³ . STi at 8 Mbps
					20% of t_{CKIP}	p-p	Extended rating. With alternate clock source ⁴ or high $\overline{\text{CKi0}}$ rate ⁵

Note 1: Characteristics are over recommended operating conditions unless otherwise stated.

Note 2: Typical figures are at 25°C, $V_{\text{DD_CORE}}$ at 1.8 V and $V_{\text{DD_IO}}$ at 3.3 V and are for design aid only: not guaranteed and not subject to production testing.

Note 3: When using internal APLL clock source and the $\overline{\text{CKi0}}$ frequency is less than or equal to the data rate.

Note 4: When using input clock source $\overline{\text{CKi0}}$ instead of the internal APLL clock source.

Note 5: When using internal APLL clock source and the $\overline{\text{CKi0}}$ frequency is higher than or equal to twice the data rate.

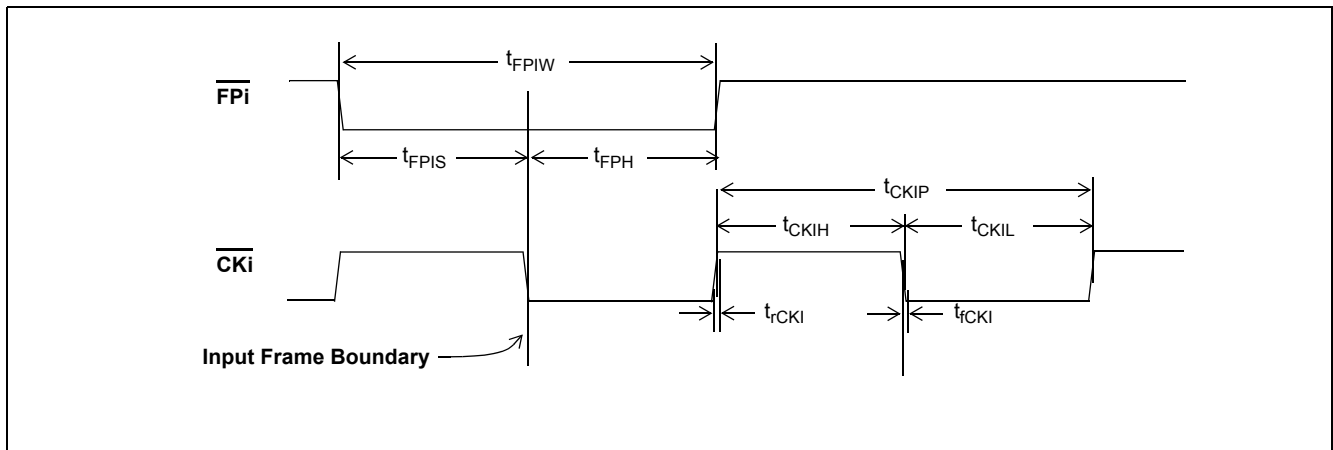
**Figure 11 - Frame Pulse Input and Clock Input**

AC Electrical Characteristics¹ - $\overline{\text{FPO0}}$ -1 and $\overline{\text{CKO0}}$ -1 (65.536 MHz) Timing

No.	Characteristic	Sym.	Min.	Typ. ²	Max.	Units	Notes ³
1	$\overline{\text{FPO0}}$ Output Frame Pulse Setup Time	t_{FPOS}	5.5		9.5	ns	$C_L=30$ pF
2	$\overline{\text{FPO0}}$ Output Frame Pulse Hold Time	t_{FPOH}	5.5		9.5	ns	$C_L=30$ pF
3	$\overline{\text{CKO0}}$ Output Clock Period	t_{CKOP}	14.5		15.5	ns	$C_L=30$ pF

AC Electrical Characteristics¹ - $\overline{\text{FPO0}}$ -1 and $\overline{\text{CKO0}}$ -1 (32.768 MHz) Timing

No.	Characteristic	Sym.	Min.	Typ. ²	Max.	Units	Notes ³
1	$\overline{\text{FPO0}}$ Output Frame Pulse Setup Time	t_{FPOS}	14.0		16.5	ns	$C_L=30$ pF
2	$\overline{\text{FPO0}}$ Output Frame Pulse Hold Time	t_{FPOH}	14.0		16.5	ns	$C_L=30$ pF
3	$\overline{\text{CKO0}}$ Output Clock Period	t_{CKOP}	30.0		31.0	ns	$C_L=30$ pF

AC Electrical Characteristics¹ - $\overline{\text{FPO0}}$ -1 and $\overline{\text{CKO0}}$ -1 (16.384 MHz) Timing

No.	Characteristic	Sym.	Min.	Typ. ²	Max.	Units	Notes ³
1	$\overline{\text{FPO0}}$ Output Frame Pulse Setup Time	t_{FPOS}	29.0		31.0	ns	$C_L=30$ pF
2	$\overline{\text{FPO0}}$ Output Frame Pulse Hold Time	t_{FPOH}	29.0		31.0	ns	$C_L=30$ pF
3	$\overline{\text{CKO0}}$ Output Clock Period	t_{CKOP}	60.5		61.5	ns	$C_L=30$ pF

AC Electrical Characteristics¹ - $\overline{\text{FPO0}}$ -1 and $\overline{\text{CKO0}}$ -1 (8.192 MHz) Timing

No.	Characteristic	Sym.	Min.	Typ. ²	Max.	Units	Notes ³
1	$\overline{\text{FPO0}}$ Output Frame Pulse Setup Time	t_{FPOS}	60.0		62.0	ns	$C_L=30$ pF
2	$\overline{\text{FPO0}}$ Output Frame Pulse Hold Time	t_{FPOH}	60.0		62.0	ns	$C_L=30$ pF
3	$\overline{\text{CKO0}}$ Output Clock Period	t_{CKOP}	121.5		122.5	ns	$C_L=30$ pF

Note 1: Characteristics are over recommended operating conditions unless otherwise stated.

Note 2: Typical figures are at 25°C, $V_{\text{DD_CORE}}$ at 1.8 V and $V_{\text{DD_IO}}$ at 3.3 V and are for design aid only: not guaranteed and not subject to production testing.

Note 3: $\overline{\text{CKO}}$ clock source set to internal 131 MHz APLL, and CKi0 and FPi0 meet all the timing requirements.

Note 4: When CKo source is set to one of the CKi/FPi, its output timings directly follow its source.

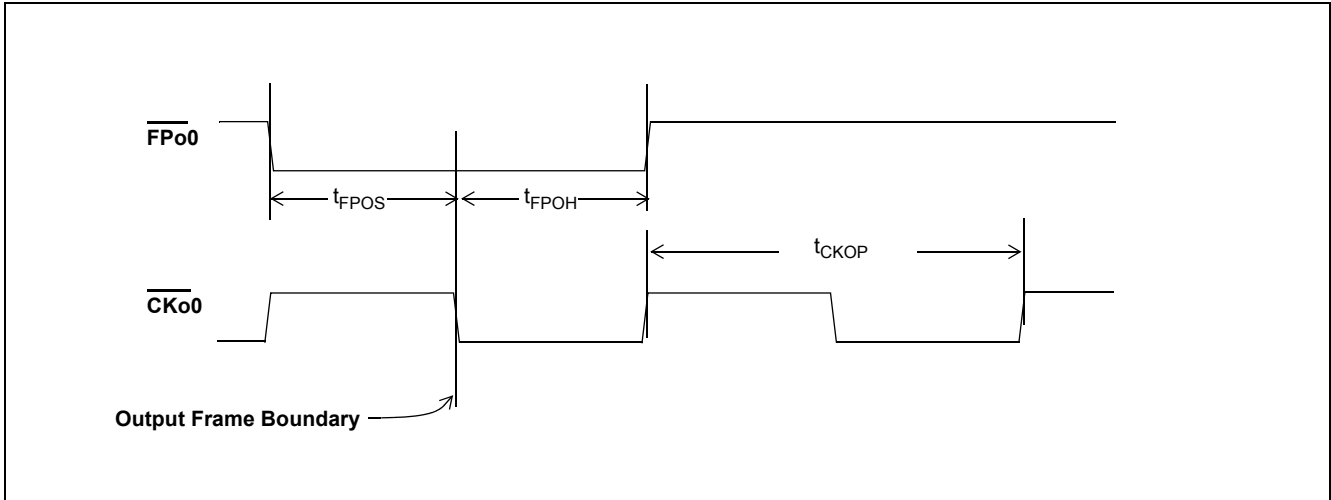

Figure 12 - ST-Bus Frame Pulse and Clock Output Timing

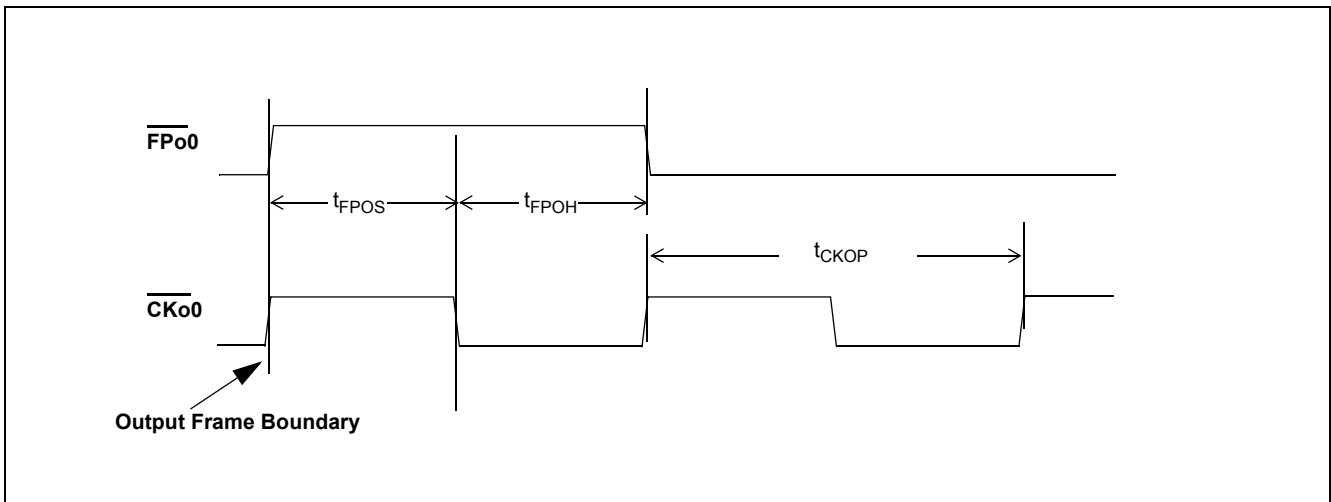

Figure 13 - GCI Frame Pulse and Clock Output Timing

AC Electrical Characteristics - Output Clock Jitter Generation

No.	Characteristic	Max.	Units	Notes ^{1,2}
1	Jitter at $\overline{CKO0-1}$ (8.192 MHz)	1050	ps-pp	
2	Jitter at $\overline{CKO0-1}$ (16.384 MHz)	1030	ps-pp	
3	Jitter at $\overline{CKO0-1}$ (32.768 MHz)	920	ps-pp	
4	Jitter at $\overline{CKO0-1}$ (65.536 MHz)	810	ps-pp	

Note 1: \overline{CKi} at 8 MHz, output clock source set to internal APLL. No jitter presented on the the Cki0 input.

Note 2: For 65.536 MHz output clock, the total loading on the output should not be larger than 10pF.

AC Electrical Characteristics¹ - Serial Data Timing² to $\overline{\text{CKi}}$

No.	Characteristic (Figure 14)	Sym.	Min.	Typ. ³	Max.	Units	Notes ⁴
1	$\overline{\text{CKi}}$ to $\overline{\text{CKo}}$ Positive edge Propagation Delay	t_{CKDP}	3.5		8	ns	$\overline{\text{CKo}}$ clock source = $\overline{\text{CKi}}$
			4.1		9.2	ns	$\overline{\text{CKo}}$ Clock source = Internal 131 MHz APLL output
2	$\overline{\text{CKi}}$ to $\overline{\text{CKo}}$ Negative edge Propagation Delay	t_{CKDN}	4.5		9.2	ns	$\overline{\text{CKo}}$ clock source = $\overline{\text{CKi}}$
			5		10.1	ns	$\overline{\text{CKo}}$ Clock source = Internal 131 MHz APLL output
3	STi to posedge $\overline{\text{CKi}}$ setup	t_{SIPS}	-0.8			ns	
4	STi to posedge $\overline{\text{CKi}}$ hold	t_{SIPH}	5.9			ns	
5	STi to negedge $\overline{\text{CKi}}$ setup	t_{SINS}	-0.8			ns	
6	STi to negedge $\overline{\text{CKi}}$ hold	t_{SINH}	5.9			ns	
7	Posedge $\overline{\text{CKi}}$ to Output Data Valid	t_{SIPV}	4.8		11.6	ns	SToA ⁵
			4.1		13.7	ns	SToB ⁵
8	Negedge $\overline{\text{CKi}}$ to Output Data Valid	t_{SINV}	5.8		12.9	ns	SToA ⁵
			4.5		14.8	ns	SToB ⁵
9	Posedge $\overline{\text{CKi}}$ to Output Data tri-state	t_{SIPZ}	4.3		14.6	ns	SToA ⁵
			4.6		14.5	ns	SToB ⁵
10	Negedge $\overline{\text{CKi}}$ to Output Data tri-state	t_{SINZ}	5.3		13	ns	SToA ⁵
			5.7		13.6	ns	SToB ⁵
11	ODE to Output Data tri-state	t_{SOZ}			10	ns	SToA $C_L = 30 \text{ pF}, R_L = 1 \text{ K}^5$
					11	ns	SToB $C_L = 30 \text{ pF}, R_L = 1 \text{ K}^5$
12	ODE to Output Data Enable	t_{SOE}	4.5		15	ns	SToA ⁵
			6		20	ns	SToB ⁵

Note 1: Characteristics are over recommended operating conditions unless other wise stated.

Note 2: All of these specifications refer to ST-BUS inputs and outputs with clock source set to $\overline{\text{CKi}}$.

Note 3: Typical figures are at 25°C, $V_{\text{DD_CORE}}$ at 1.8 V and $V_{\text{DD_IO}}$ at 3.3 V and are for design aid only: not guaranteed and not subject to production testing.

Note 4: Loads on all serial outputs set to 30 pF.

Note 5: High Impedance is measured by pulling to the appropriate rail with R_L , with timing corrected to cancel time taken to discharge C_L .

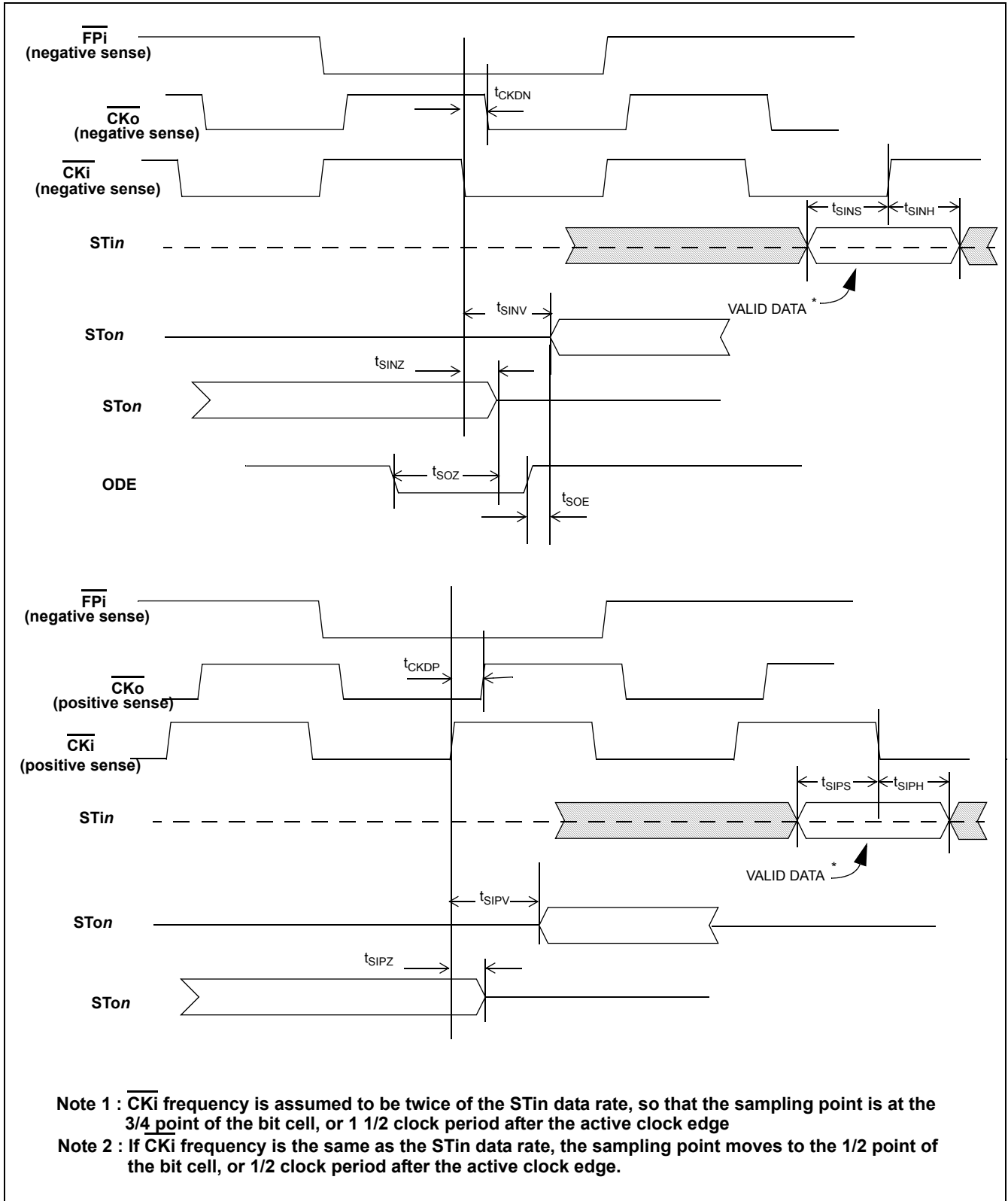

Figure 14 - Serial Data Timing to \overline{CKi}

AC Electrical Characteristics - Serial Data Timing¹ to $\overline{\text{CKo}}^2$

No.	Characteristic (Figure 15)	Sym.	Min.	Typ. ³	Max.	Units	Notes ⁴
1	STi to posedge $\overline{\text{CKo}}$ setup	t _{SOPS}	7.3			ns	
2	STi to posedge $\overline{\text{CKo}}$ hold	t _{SOPH}	-2.0			ns	
3	STi to negedge $\overline{\text{CKo}}$ setup	t _{SONS}	7.3			ns	
4	STi to negedge $\overline{\text{CKo}}$ hold	t _{SONH}	-2.0			ns	
5	Posedge $\overline{\text{CKo}}$ to Output Data Valid	t _{SOPV}	0.1		2.7	ns	SToA ⁴
			0		4.6	ns	SToB ⁴
6	Negedge $\overline{\text{CKo}}$ to Output Data Valid	t _{SONV}	-1.2		1.7	ns	SToA ⁴
			-1.6		3.7	ns	SToB ⁴
7	Posedge $\overline{\text{CKo}}$ to Output Data tri-state	t _{SOPZ}	0.9		4.9	ns	SToA ⁴
			0.1		5.1	ns	SToB ⁴
8	Negedge $\overline{\text{CKo}}$ to Output Data tri-state	t _{SONZ}	0.4		4.7	ns	SToA ⁴
			0		4.8	ns	SToB ⁴
9	$\overline{\text{CKo}}1$ to $\overline{\text{CKo}}0$ skew	t _{CKOS}			1.2	ns	

Note 1: Data Capture points vary with respect to CKo edge depending on clock rates & fractional delay settings.

Note 2: All of these specifications refer to ST-BUS inputs, ST-BUS outputs and CKo outputs set to internal clock source.

Note 3: Typical figures are at 25°C, V_{DD_CORE} at 1.8 V and V_{DD_IO} at 3.3 V and are for design aid only: not guaranteed and not subject to production testing.

Note 4: Loads on all serial outputs set to 30 pF.

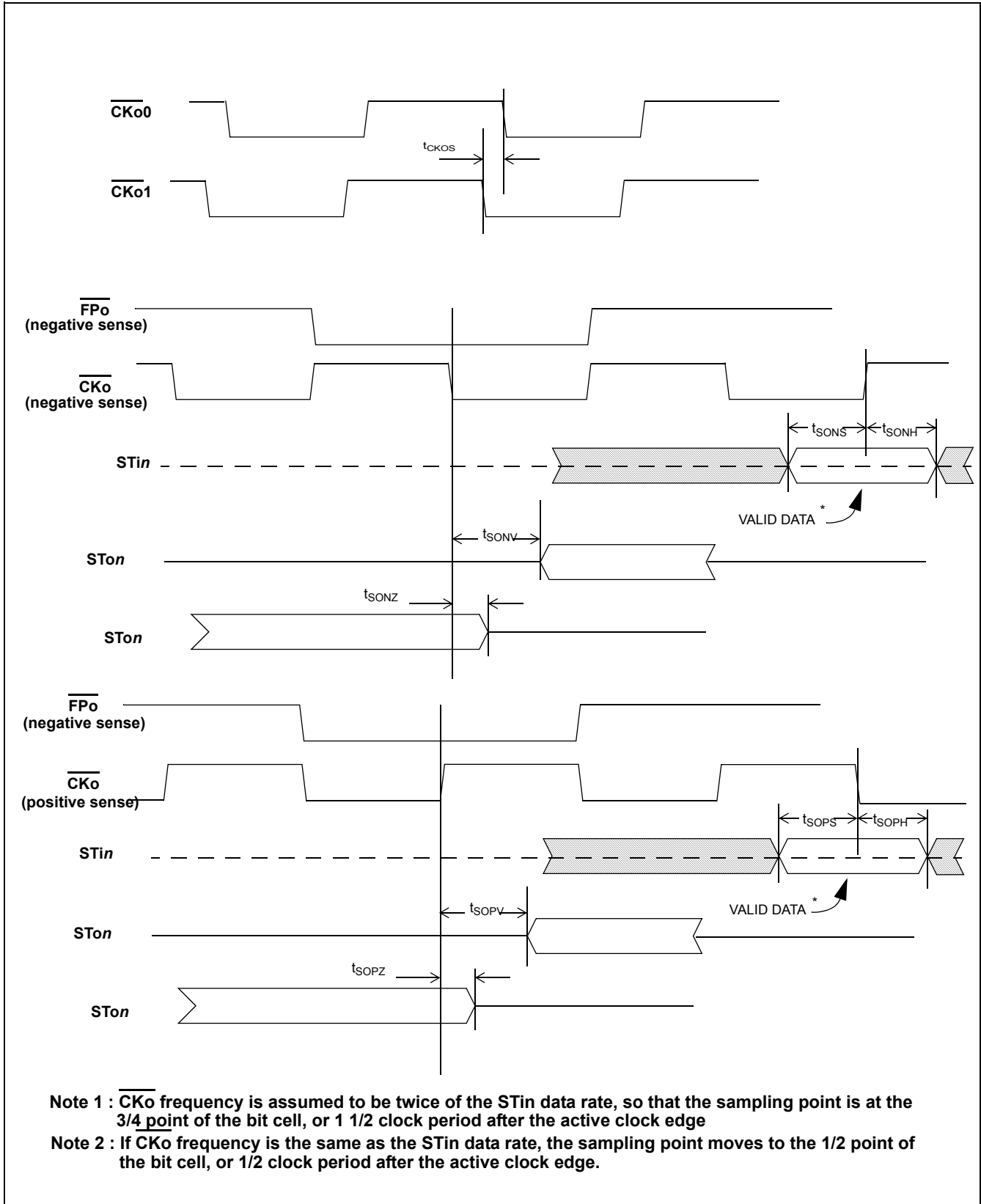

Figure 15 - Serial Data Timing to CKo

AC Electrical Characteristics - Microprocessor Bus Interface

No	Characteristics (Figure , & Figure 17)	Sym.	Min.	Typ. ¹	Max.	Units	Notes
1	\overline{DS} Recovery	t_{DSRE}	5			ns	
2	\overline{CS} Recovery	t_{CSRE}	0			ns	
3	\overline{CS} asserted setup to \overline{DS} asserted	t_{CSS}	0			ns	
4	Address, SIZ1-0, R/W setup to \overline{DS} asserted	t_{ADS}	0			ns	
5	\overline{CS} hold from \overline{DS} deasserted	t_{CSH}	0			ns	
6	Address, SIZ0-1, R/W hold from \overline{DS} deasserted	t_{ADH}	0			ns	
7	Data valid to \overline{DTA} asserted on read	t_{DSR}	0			ns	$C_L = 50 \text{ pF}$, $R_L = 1 \text{ k}^2$
8	\overline{CS} deasserted to Data tri-stated on read	t_{DZ}			5	ns	$C_L = 50 \text{ pF}$, $R_L = 1 \text{ k}^2$
9	Data setup to \overline{DS} asserted on write	t_{WDS}	0			ns	
10	\overline{CS} asserted to \overline{WAIT} deasserted	t_{CSWA}			9	ns	$C_L = 30 \text{ pF}$, $R_L = 1 \text{ K}^2$
11	Data hold from \overline{DTA} asserted on write	t_{DHW}	0			ns	
12	\overline{DS} asserted to \overline{WAIT} Asserted	t_{WDD}			9	ns	$C_L = 50 \text{ pF}$, $R_L = 1 \text{ k}^2$
13	\overline{WAIT} deasserted to $\overline{DTA/BERR}$ asserted skew	t_{AKS}	0		10	ns	$C_L = 50 \text{ pF}$, $R_L = 1 \text{ k}^2$
14	\overline{DS} asserted to \overline{DTA} Asserted	t_{AKD}	35		155	ns	Connection Memory
			50		75	ns	All other registers
15	\overline{DS} deasserted to \overline{DTA} Deasserted	t_{AKH}			7	ns	$C_L = 30 \text{ pF}$, $R_L = 1 \text{ K}^2$
16	\overline{CS} deasserted to \overline{DTA} tri-stated	t_{DTHZ}			13	ns	$C_L = 30 \text{ pF}$, $R_L = 1 \text{ K}^2$
17	\overline{CS} deasserted to \overline{WAIT} tri-stated	t_{WAHZ}			6	ns	$C_L = 30 \text{ pF}$, $R_L = 1 \text{ K}^2$
18	\overline{BE} or $\overline{UDS/LDS}$ skew	t_{DSK}			20	ns	
19	\overline{BE} or $\overline{UDS/LDS}$ to \overline{DS} set-up	t_{BEDS}	0				

Note 1: Typical figures are at 25°C, V_{DD_CORE} at 1.8 V and V_{DD_IO} at 3.3 V and are for design aid only: not guaranteed and not subject to production testing.

Note 2: High Impedance is measured by pulling to the appropriate rail with R_L , with timing corrected to cancel time taken to discharge C_L .

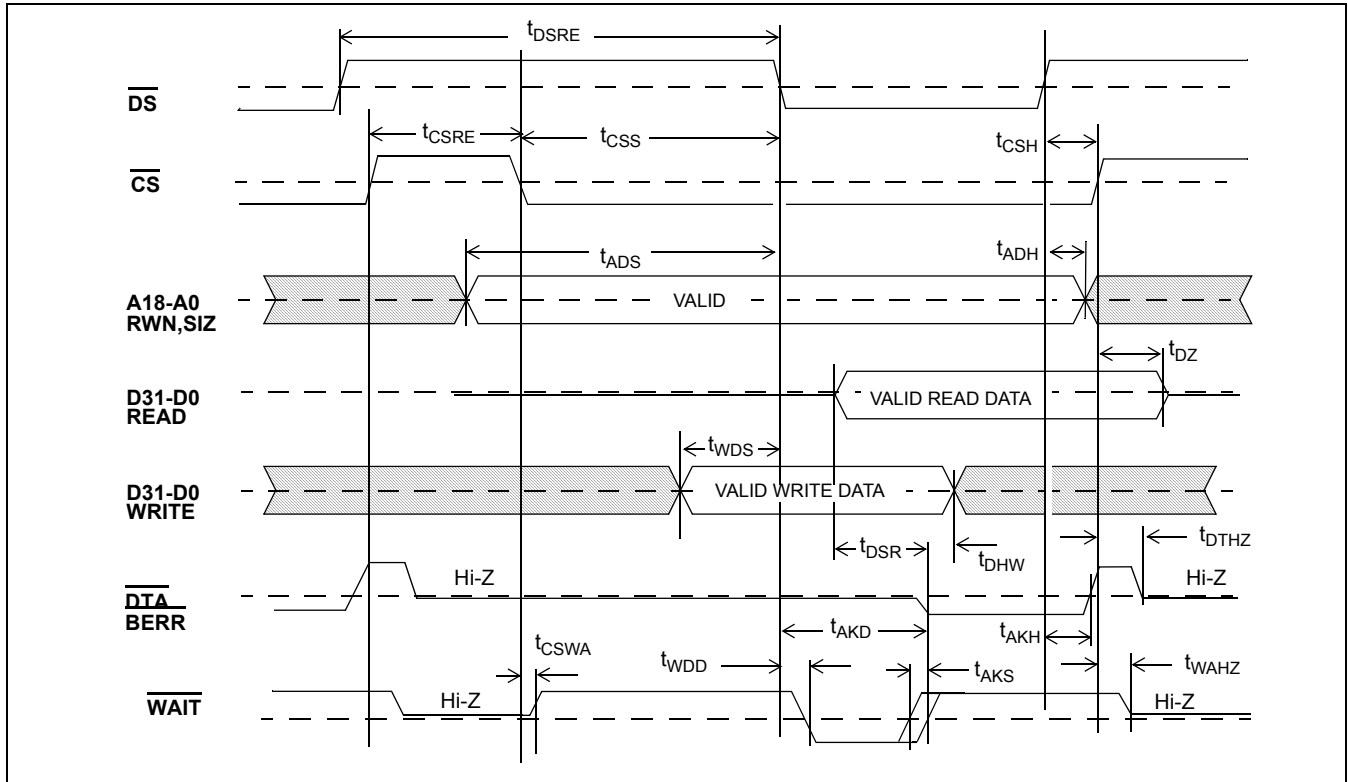

Figure 16 - Microprocessor Bus Interface Timing

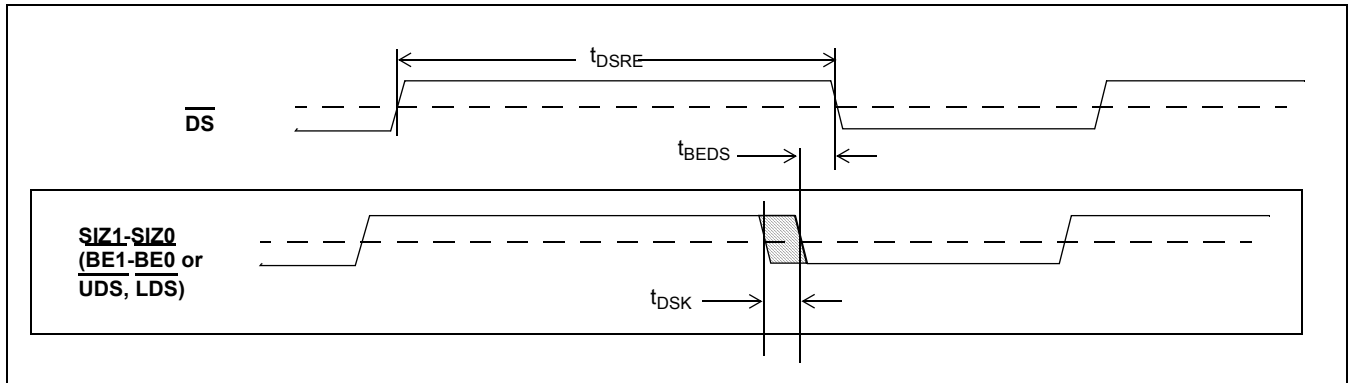

Figure 17 - Intel Mode Timing

AC Electrical Characteristics¹ - IEEE 1149.1 Test Port and $\overline{\text{PWR}}$ Pin Timing

No.	Characteristic (Figure 18)	Sym.	Min.	Typ. ²	Max.	Units	Notes
1	TCK Clock Period	t_{TCKP}	100			ns	
2	TCK Clock Frequency	t_{TCKF}			10	MHz	
3	TCK Clock Pulse Width High	t_{TCKH}	20			ns	
4	TCK Clock Pulse Width Low	t_{TCKL}	20			ns	
5	TMS Set-up Time	t_{TMSS}	10			ns	
6	TMS Hold Time	t_{TMSH}	10			ns	
7	TDi Input Set-up Time	t_{TDis}	20			ns	
8	TDi Input Hold Time	t_{TDIH}	60			ns	
9	TDo Output Delay	t_{TDOD}			20	ns	$C_L = 30 \text{ pF}$
10	$\overline{\text{TRST}}$ pulse width	t_{TRSTW}	20			ns	
11	$\overline{\text{PWR}}$ pulse width	t_{TPWR}	20			ns	

Note 1: Characteristics are over recommended operating conditions unless otherwise stated.

Note 2: Typical figures are at 25°C, $V_{\text{DD_CORE}}$ at 1.8 V and $V_{\text{DD_IO}}$ at 3.3 V and are for design aid only: not guaranteed and not subject to production testing.

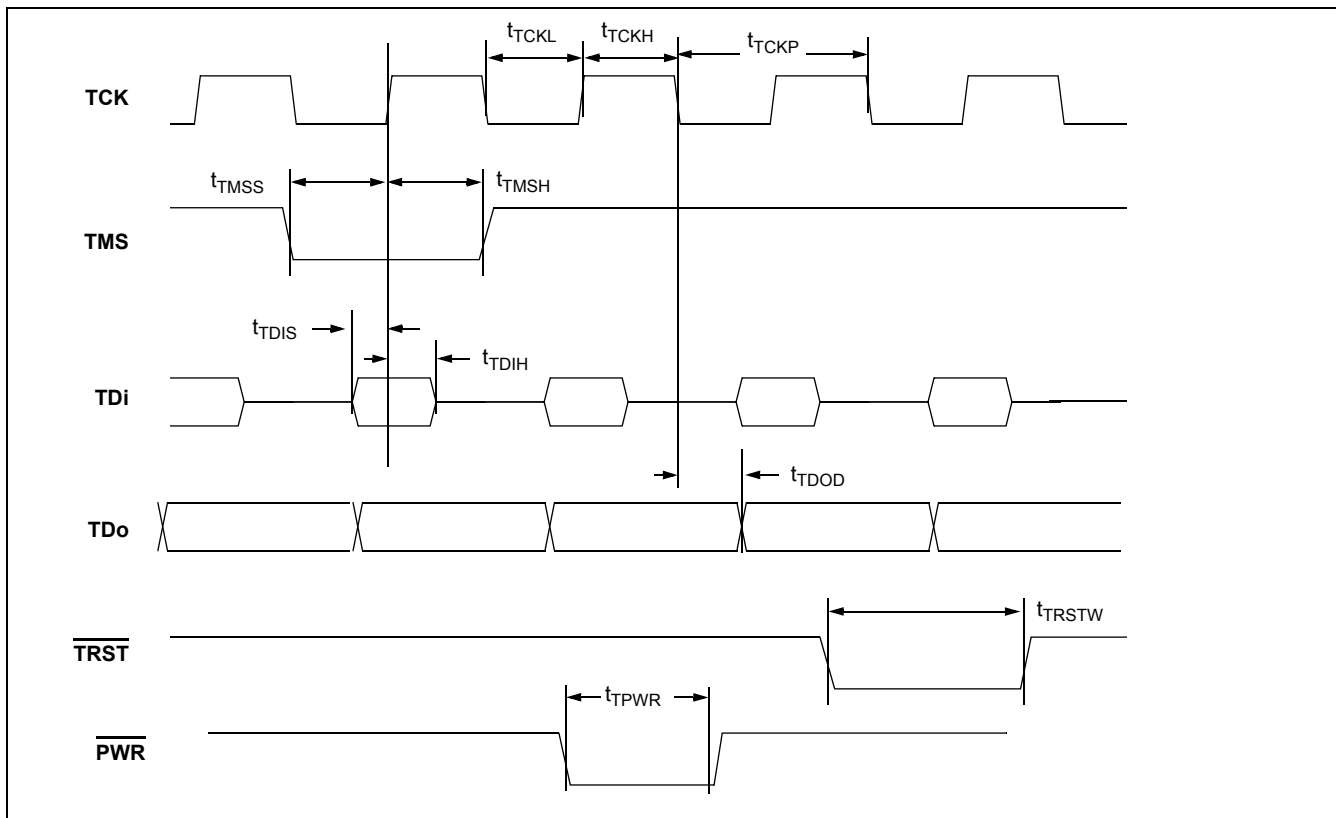
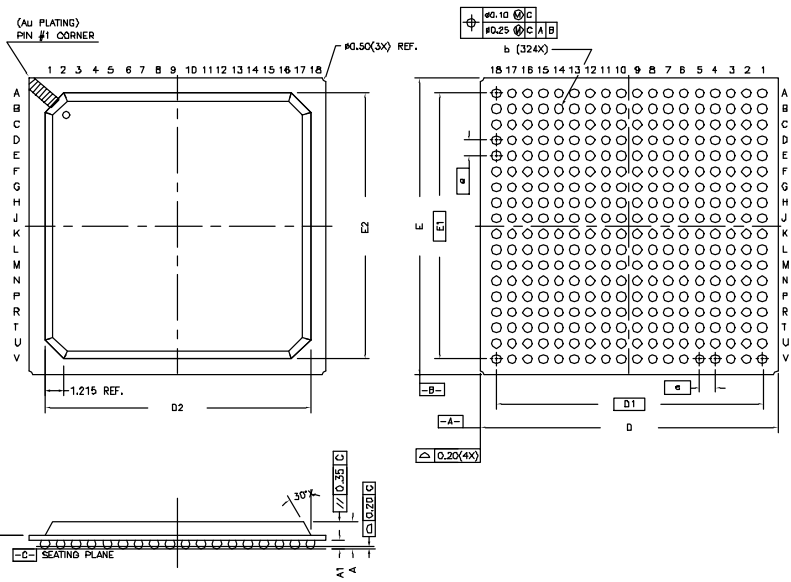

Figure 18 - IEEE 1149.1 Test Port & $\overline{\text{PWR}}$ Reset Timing



SYMBOL	MILLIMETER		
	MIN	NOM	MAX
A	1.52	1.71	1.90
A1	0.40	0.50	0.60
A2	0.36 Ref.		
A3	0.85 Ref.		
b	0.50	0.60	0.70
D	16.80	19.00	19.20
D1	17.00 Ref.		
D2	16.80	17.00	17.20
E	18.80	19.00	19.20
E1	17.00 Ref.		
E2	16.80	17.00	17.20
e	1.00 Ref.		

Confirms to JEDEC MS-034
AAG-1 iss. A

NOTE:

1. ALL DIMENSIONS AND TOLERANCES CONFORM TO ANSI Y14.5M-1982.
2. DIMENSION "b" IS MEASURED AT THE MAXIMUM SOLDER BALL DIAMETER
3. PRIMARY DATUM \square -C- AND SEATING PLANE ARE DEFINED BY THE SPHERICAL CROWNS OF THE SOLDER BALLS.
4. ALL DIMENSIONS ARE IN MILLIMETERS.
5. NOT TO SCALE.
6. DETAILS OF A1 CORNER ARE OPTIONAL, AND MAY CONSIST OF INK DOT, LASER MARK OR METALISED MARKING, BUT MUST BE LOCATED WITHIN ZONE INDICATED.

© Zarlink Semiconductor 2003 All rights reserved.

ISSUE	1			
ACN				
DATE	15 Jul 03			
APPRD.				



Package Code	GA
Previous package codes	Package Outline for 324, PBGA (19x19)mm, 1.00 Pitch
	100778



**For more information about all Zarlink products
visit our Web Site at
www.zarlink.com**

Information relating to products and services furnished herein by Zarlink Semiconductor Inc. or its subsidiaries (collectively "Zarlink") is believed to be reliable. However, Zarlink assumes no liability for errors that may appear in this publication, or for liability otherwise arising from the application or use of any such information, product or service or for any infringement of patents or other intellectual property rights owned by third parties which may result from such application or use. Neither the supply of such information or purchase of product or service conveys any license, either express or implied, under patents or other intellectual property rights owned by Zarlink or licensed from third parties by Zarlink, whatsoever. Purchasers of products are also hereby notified that the use of product in certain ways or in combination with Zarlink, or non-Zarlink furnished goods or services may infringe patents or other intellectual property rights owned by Zarlink.

This publication is issued to provide information only and (unless agreed by Zarlink in writing) may not be used, applied or reproduced for any purpose nor form part of any order or contract nor to be regarded as a representation relating to the products or services concerned. The products, their specifications, services and other information appearing in this publication are subject to change by Zarlink without notice. No warranty or guarantee express or implied is made regarding the capability, performance or suitability of any product or service. Information concerning possible methods of use is provided as a guide only and does not constitute any guarantee that such methods of use will be satisfactory in a specific piece of equipment. It is the user's responsibility to fully determine the performance and suitability of any equipment using such information and to ensure that any publication or data used is up to date and has not been superseded. Manufacturing does not necessarily include testing of all functions or parameters. These products are not suitable for use in any medical products whose failure to perform may result in significant injury or death to the user. All products and materials are sold and services provided subject to Zarlink's conditions of sale which are available on request.

Purchase of Zarlink's I²C components conveys a licence under the Philips I²C Patent rights to use these components in and I²C System, provided that the system conforms to the I²C Standard Specification as defined by Philips.

Zarlink, ZL and the Zarlink Semiconductor logo are trademarks of Zarlink Semiconductor Inc.

Copyright Zarlink Semiconductor Inc. All Rights Reserved.

TECHNICAL DOCUMENTATION - NOT FOR RESALE