

144x144 3.2 Gbps Crosspoint Switch with Integrated CDRs, Input Equalization & Pre-Emphasis

M21156

Most Highly Integrated, Highest Performance, Lowest Power Crosspoint Switch Reduces System Cost and Complexity

Built on three generations of industry-leading crosspoint switches, the M21156, designed for today's demanding telecom and datacom applications, is a low-power CMOS, high-speed 144x144 crosspoint switch with 144 independent CDRs, and robust signal conditioning circuits for driving and receiving high-speed signals through backplanes.

The device consumes as low as 17 W of power (typical) with all channels and CDRs operational. In addition, the PowerScaler™ features offer dynamically scalable switch settings to further reduce power consumption. Unused portions of the core can be automatically (SmartPower™) or manually turned off, without effecting the operation of the remaining channels.

Each input has a dedicated high-jitter tolerant, low-jitter generation CDR with internal loop filter. All CDRs use a common, single frequency reference clock (19.44 MHz) for internal calibration and acquisition. Each CDR operates independently at any data rate from 1.0 to 1.6 Gbps, or 2.0 to 3.2 Gbps.

The signal conditioning features of the M21156 include per channel programmable input equalizer (IE) and output pre-emphasis (PE) circuits. The IE removes ISI jitter, which is usually caused by PCB skin effect losses. The IE circuit opens the input data eye in applications where long PCB traces and cables are used. There are four settings available for the input equalizer, allowing flexibility in adjusting the equalization level on a per-channel basis.

KEY FEATURES

- › Integrated per-channel multi-rate CDRs, with bit rates of 1.0–3.2 Gbps
- › Programmable input equalizer to remove deterministic jitter (ISI)
- › Programmable output pre-emphasis for driving long board traces and cables
- › Performance exceeding SONET requirements with 0.65 UI jitter tolerance and 1.5 mUI (rms) jitter generation
- › Low power consumption of 17 W, nearly 60% power savings compared to an equivalent circuit with external CDRs
- › PowerScaler™ for further power reduction based on system needs
- › Built-in system test features such as JitterMeter™ and PRBS Tx/Rx
- › Supports SONET, GbE, 10GbE, Fibre Channel (1x, 2x, 10x) and Infiniband applications
- › Programmable input equalization with CDR for random and deterministic jitter reduction

The PE provides a boost of the high frequency content of the output signal, such that the data eye remains open after passing through a long interconnect of PCB traces and cables. There are two amplitude settings and two duration settings that can be selected on a global basis.

The device supports data rates from 0 to 3.2 Gbps on each channel, allowing any combination of SONET, Fibre Channel (1x, 2x, 10x), InfiniBand, Gigabit Ethernet and parallel 10 Gbps Ethernet traffic. For applications that do not require an integrated CDR, the M21151, 144x144 crosspoint switch with input equalization and pre-emphasis can be used.



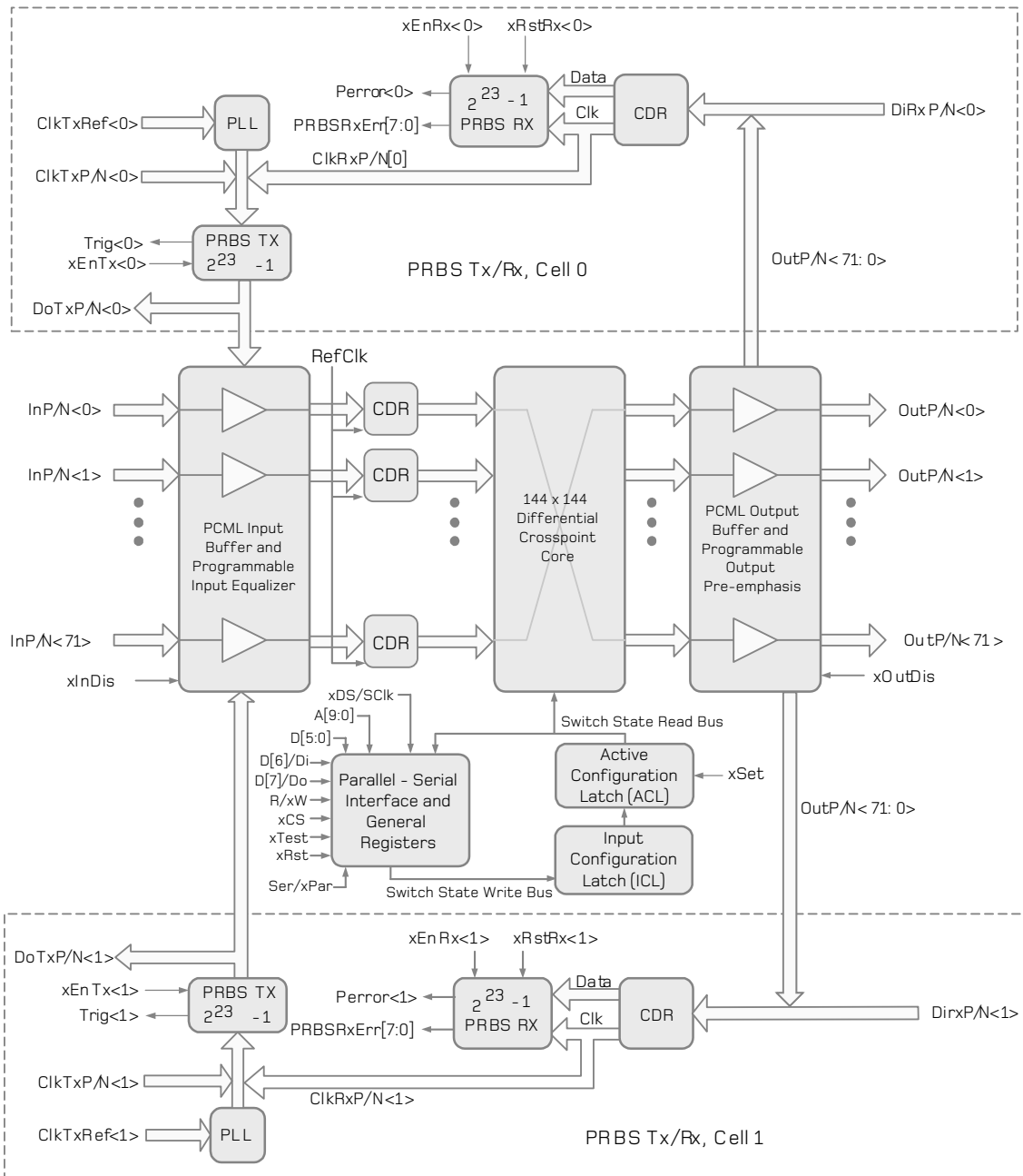

M21156 Block Diagram

Product Features

Applications

- Large N x N cascaded switch fabrics, up to 33 Terabits/second
- DWDM switches

- Fiber-optic telecom systems (OC-48/OC-48 FEC)
- Telecom & datacom switches

- Storage area network (SAN) switches (1x, 2x, and 10x Fibre Channel)
- Infiniband switches

- 10 GbE parallel and GbE networks
- Packet switching
- High-speed automated test equipment

www.mindspeed.com/salesoffices
 General Information: (949) 579-3000
 Headquarters – Newport Beach
 4000 MacArthur Blvd., East Tower
 Newport Beach, CA 92660-3007
 21156-BRF-001-A M02-0750

© 2003 Mindspeed Technologies™. All rights reserved. Mindspeed and the Mindspeed logo are trademarks of Mindspeed Technologies. All other trademarks are the property of their respective owners. Although Mindspeed Technologies strives for accuracy in all its publications, this material may contain errors or omissions and is subject to change without notice. This material is provided as is and without any express or implied warranties, including merchantability, fitness for a particular purpose and non-infringement. Mindspeed Technologies shall not be liable for any special, indirect, incidental or consequential damages as a result of its use.

MINDSPEED
 BUILD IT FIRST™