

COLOR TV VIDEO PROCESSOR

- MATRIXING OF R, G, B SIGNAL FROM (R-Y) AND (B-Y)
- ELECTRONIC CONTROL OF CONTRAST, BRIGHTNESS AND SATURATION
- THREE CHANNELS VIDEO SWITCH, FOR SELECTION OF INTERNAL SIGNAL (broadcast) OR EXTERNAL R, G, B INFORMATION (teletext, TV games, home computer)
- AUTOMATIC COLOR PICTURE TUBES CUT-OFF ADJUSTMENT

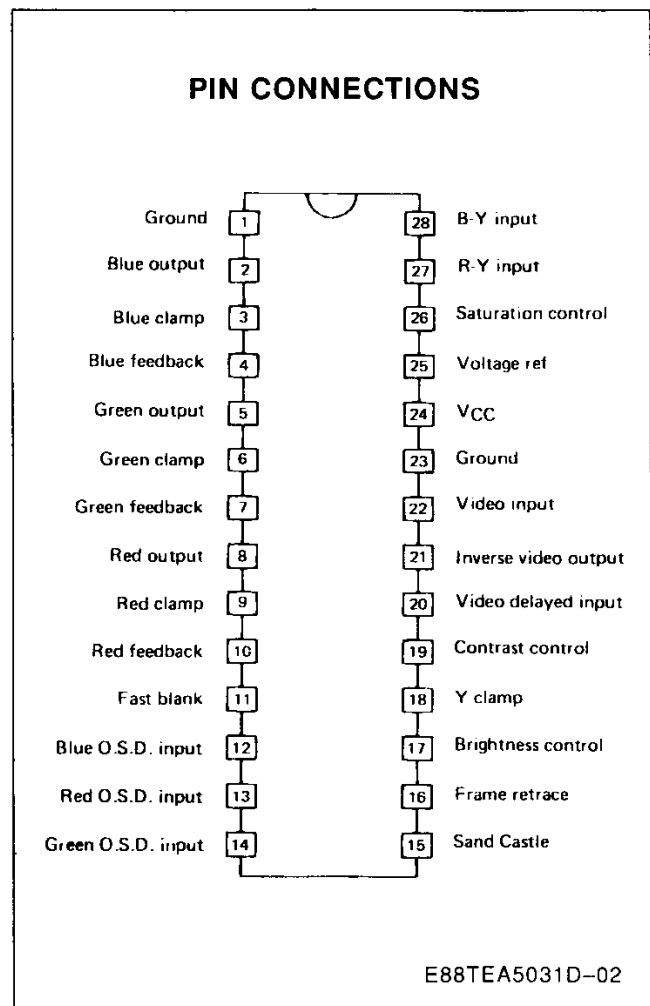
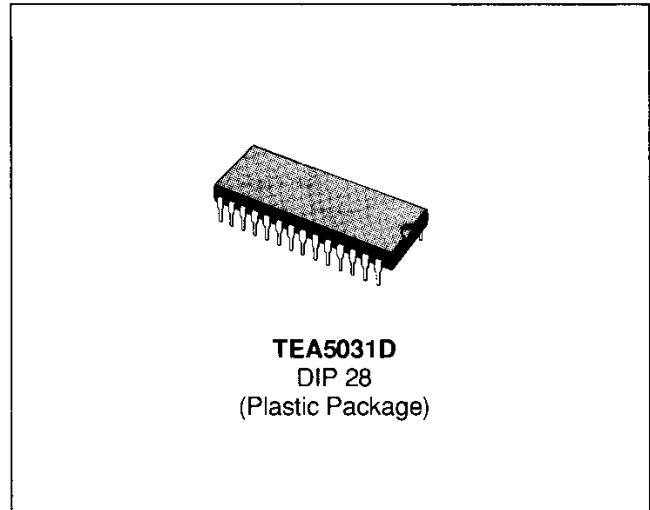

DESCRIPTION

The TEA5031D is a color TV video processor compatible with all standards PAL/SECAM/NTSC and new needs such as teletext, Antiope, TV games, remote control etc...

BLOCK DIAGRAM

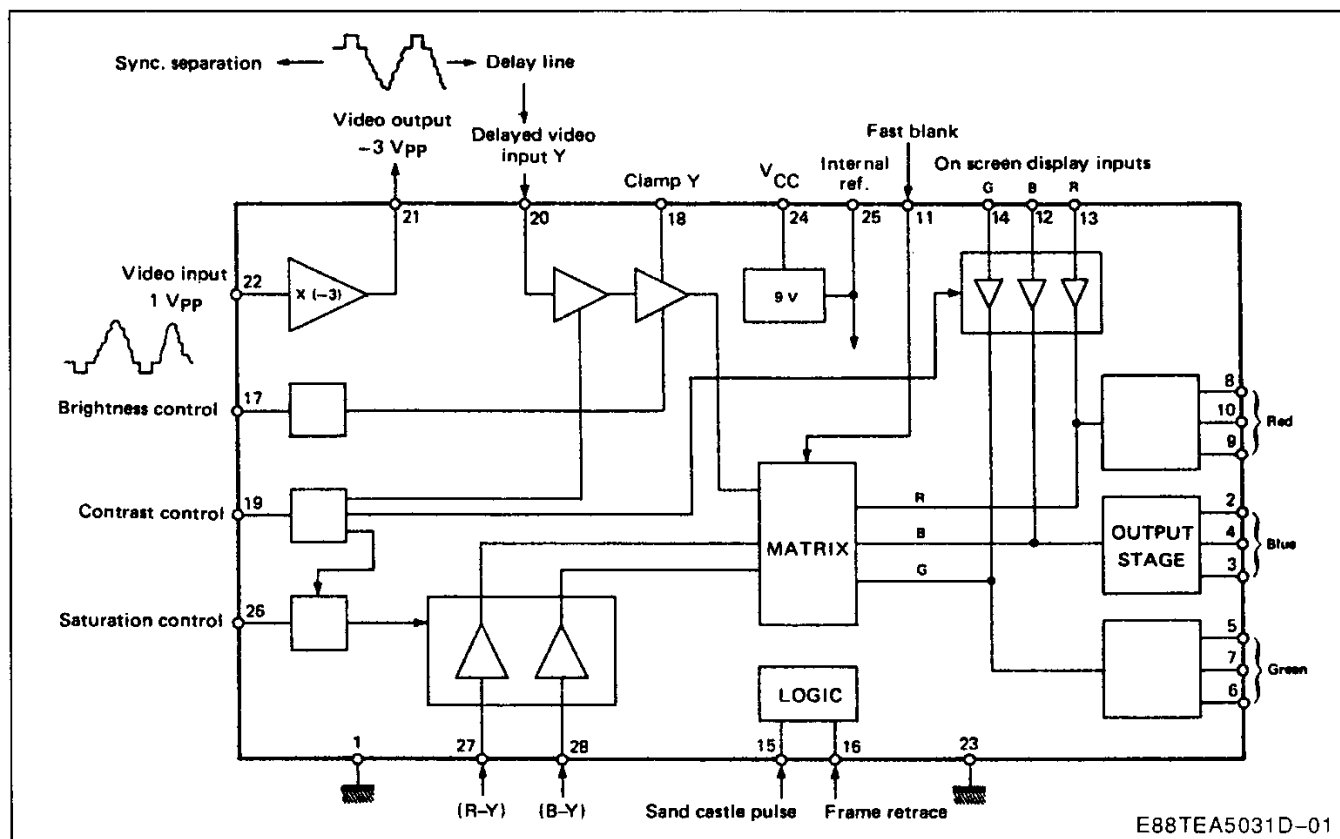

GENERAL DESCRIPTION

In order to ensure compatibility with standard video transmission systems the luma input is a high impedance, AC coupled, designed to accept a 1V video signal. After a X3 gain voltage amplifier the inverted luma signal is brought out to the luma delay line. This output is low impedance to match the delay accurately.

Following the luma delay line the video is controlled by an electronic gain control with a range of 40dB.

The DC luma level is locked on the black level (cut-off current) with a range of $\pm 1V$ depending of brightness. The DC voltage level is clamped during each line retrace and an external capacitor holds this voltage during the line trace.

After brightness and contrasts controls the luminance is fed to the matrix with R-Y and B-Y signals.

The R-Y and B-Y inputs are high impedance with AC coupling, compatible with decoder ICs such as the TEA5630 for SECAM and the TEA5620 for PAL.

The voltage gain of R-Y and B-Y is controlled by saturation. The saturation is in tracking with contrast and then the R-Y and B-Y signals are fed to the matrix and summed with on-screen display signals which are controlled in gain by the luma contrast control. Each input is AC coupled and black level

clamped using the coupling capacitor as the storage element for the clamp voltage.

All the controls have an active range of 0.5 to 4.5 V making them compatible with D/A converter derived control signals, such as those from remote control systems. The three on-chip output stages are high gain class B amplifiers with the gain set by parallel feedback resistor.

This gives a well defined gain and stable output voltage level. The beam current in each cathode of the picture tube is monitored by a high-voltage PNP transistor or the TEA5101A video amplifier. A sample of this current is fed back to the IC.

In the luma signal a reference black level is inserted during the line and frame blanking periods. While this reference level is present, and after the frame flyback, the output stage feedback input goes high impedance and an internal comparator is activated.

This circuit compares an internal reference voltage (2V typ) to the voltage developed across an external resistor by the picture tube beam current, and the output voltage is trimmed to get the desired cathode current value.

An internal logic delivers blanking and clamping pulses from the normalized sandcastle and frame retrace signals.

A supersandcastle and a frame blanking signals can be used only if the frame blanking pulse is longer or equal than the frame level of SSC.

ABSOLUTE MAXIMUM RATINGS

Symbol	Parameter	Value	Unit
V _{CC}	Supply Voltage	16	V
T _{amb}	Operating Ambient Temperature	0 to 70	°C
T _{stg}	Storage Temperature Range	- 65 to 150	°C

THERMAL DATA



R _{th(j-a)}	Junction-ambient Thermal Resistance	55	°C/W
----------------------	-------------------------------------	----	------

ELECTRICAL OPERATING CHARACTERISTICS

T_{amb} = + 25°C ; V_{CC} = 12V (unless otherwise noted)

Symbol	Parameter	Value			Unit
		Min.	Typ.	Max.	
V _{CC}	Supply voltage Pin 24	10.8	12	13.2	V
I _{CC}	Supply Current Pin 24		55		mA
V _Z	Internal Voltage Ref. Pin 25		9		V
	Input-output characteristics				
	Video Input Pin 22		1		V _{PP}
	Output Voltage Inv. Video (V ₂₂ = 1 V _{PP}) Pin 21		3		V _{PP}
	Max Output Voltage Swing Pin 21		7		V _{PP}
	- 3 dB Bandwidth Pins 2-5-8	4.5	5		MHz
	(R-Y) Input Voltage (100% modulation) Pin 27		1.4	2	V _{PP}
	(B-Y) Input Voltage (100% modulation) Pin 28		1.0	2	V _{PP}
	- 3 dB Bandwidth	1.5			MHz
	Luma Gain				
	G _{21/22} Pin 21	8.5	10	11.5	dB
	G _{2/20} , G _{5/20} , G _{8/20} at Max Adjustment Pins 2-5-8	13.5	15.5	19.1	dB
	Differential Gain Fault : Luma Channel			0.5	dB
	Chroma Gain				
	G _{8/27} at Max Adjustment	8.8	11.6	14.5	dB
	G _{2/28} at Max Adjustment	12	14.7	17.2	dB
	Chroma Gain Ratio at Max Adjustment	1.28	1.40	1.48	
	Voltage Control for Electronic Potentiometers				
	Contrast (pin 19) Saturation (pin 26)				
	Range of Adjustment				
	V ₁₉ = 5V ; V ₂₆ = 5V		G _{max}		dB
	V ₁₉ = 0V ; V ₂₆ = 0V Attenuation	40	46		dB
	Brightness (pin 17)				
	V _{out} Adjustment (V ₁₇ varying from 0 to 5V)		± 1		V
	On Screen Display Inputs Pins 12-13-14				
	OSD Input Voltage (black to white level)		1	2	V
	OSD Gain (V _{2/12} ; V _{8/13} ; V _{5/14})	13.5	15	17	dB
	OSD Generator Max Impedance			75	Ω
	- 3 dB Bandwidth	5			MHz
	Fast Blanking Threshold		0.5		V
	Max Output Voltage Swing Pins 2-5-8	7	8		V _{PP}
	Cut-off Control Feedback Threshold Pins 4-7-10	1.7	2	2.4	V

ELECTRICAL OPERATING CHARACTERISTICS (continued)

Symbol	Parameter	Value			Unit
		Min.	Typ.	Max.	
	Sand-Castle Input Pin 15				
	Clamp Y  8V		8		V
	Line Blanking  2.5V		2.5		V
	Frame Return Input Voltage Pin 16		2.5		V
	Control Current (V15 = V16 = 4V)		0.5		mA
	Matrix Coefficient				
	Red Output (V5/V8 with V27 = 1V ; V28 = 0 ; V20 = 0)		0.51		
	Blue Output (V5/V2 with V27 = 0 ; V28 = 1 ; V20 = 0)		0.19		

APPLICATION CIRCUIT

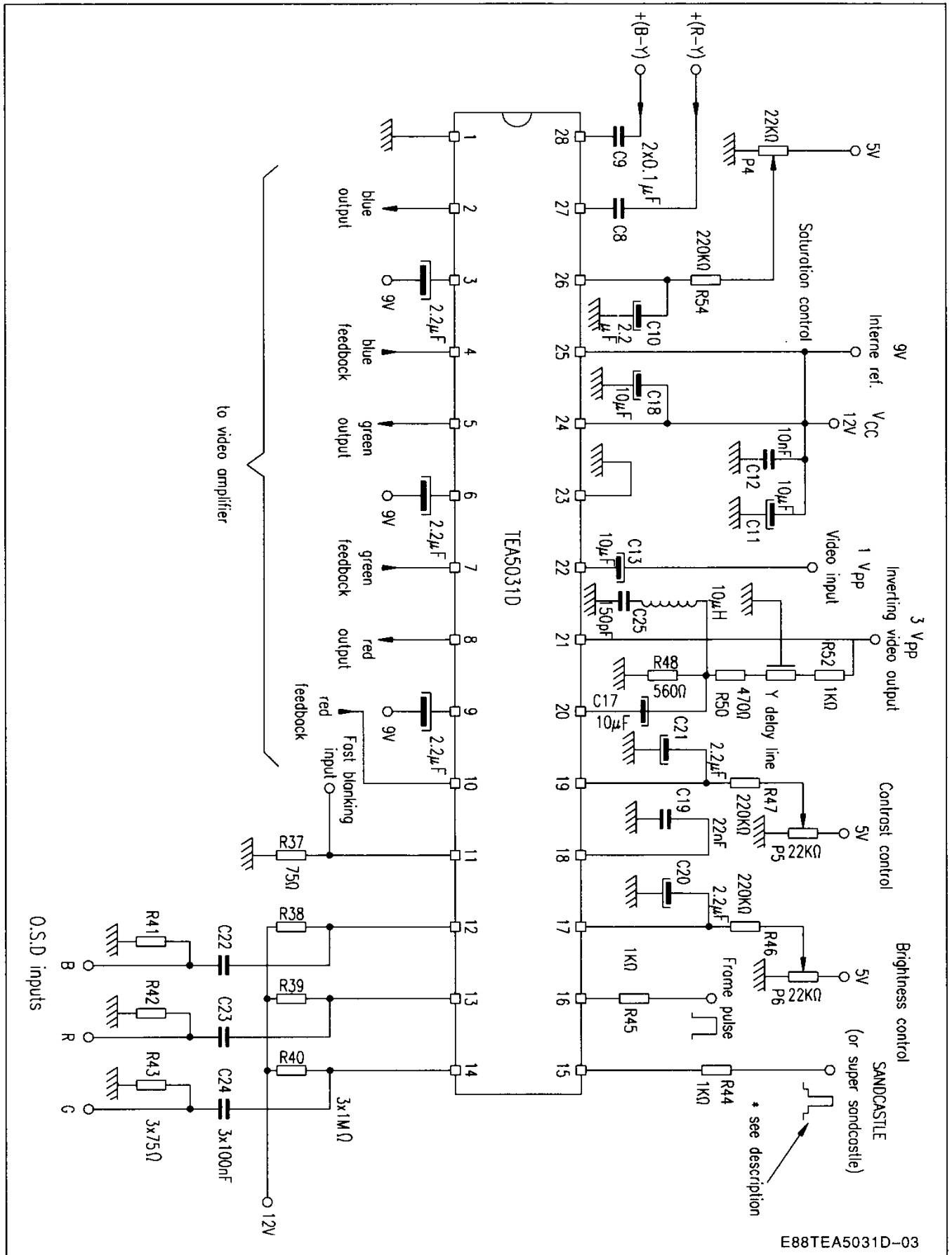

E88TEA5031D-03

APPLICATION CIRCUIT
FULFILLING THE EURODCART SPECIFICATIONS

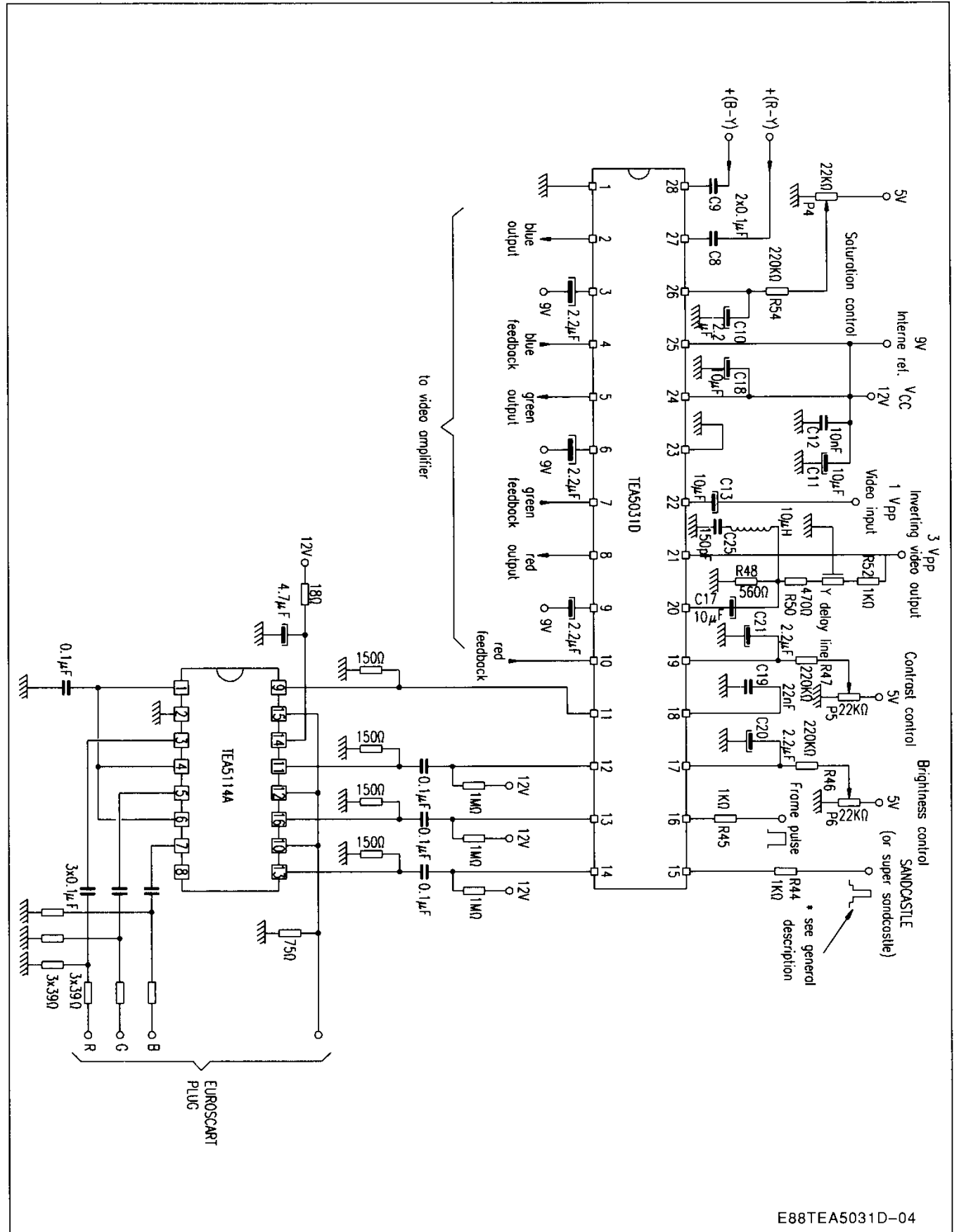

E88TEA5031D-04

PACKAGE MECHANICAL DATA

28 PINS – PLASTIC DIP

