

QUAD PARALLEL REGISTER WITH ENABLE

- EDGE-TRIGGERED D-TYPE INPUTS
- BUFFERED POSITIVE EDGE-TRIGGERED CLOCK
- BUFFERED COMMON ENABLE INPUT
- TRUE AND COMPLEMENT OUTPUT
- INPUT CLAMP DIODES LIMIT HIGH SPEED TERMINATION EFFECTS
- FULLY TTL AND CMOS COMPATIBLE

DESCRIPTION

The T74LS379 is a 4-Bit Register with buffered common Enable. This device is similar to the T74LS175 but feature the common Enable rather than common Master Reset.

PIN NAMES

\bar{E}	ENABLE (active LOW) INPUT
D_0 - D_3	DATA INPUTS
CP	CLOCK (active HIGH going edge) INPUT
Q_0 - Q_3	TRUE OUTPUTS
\bar{Q}_0 - \bar{Q}_3	COMPLEMENTS OUTPUTS

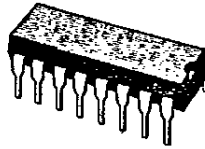

B1
(Plastic Package)

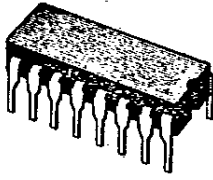

D1
(Ceramic Package)



M1
(Micro Package)



C1
(Plastic Chip Carrier)

ORDER CODES :

T74LS379 D1	T74LS379 C1
T74LS379 B1	T74LS379 M1

PIN CONNECTION (top view)

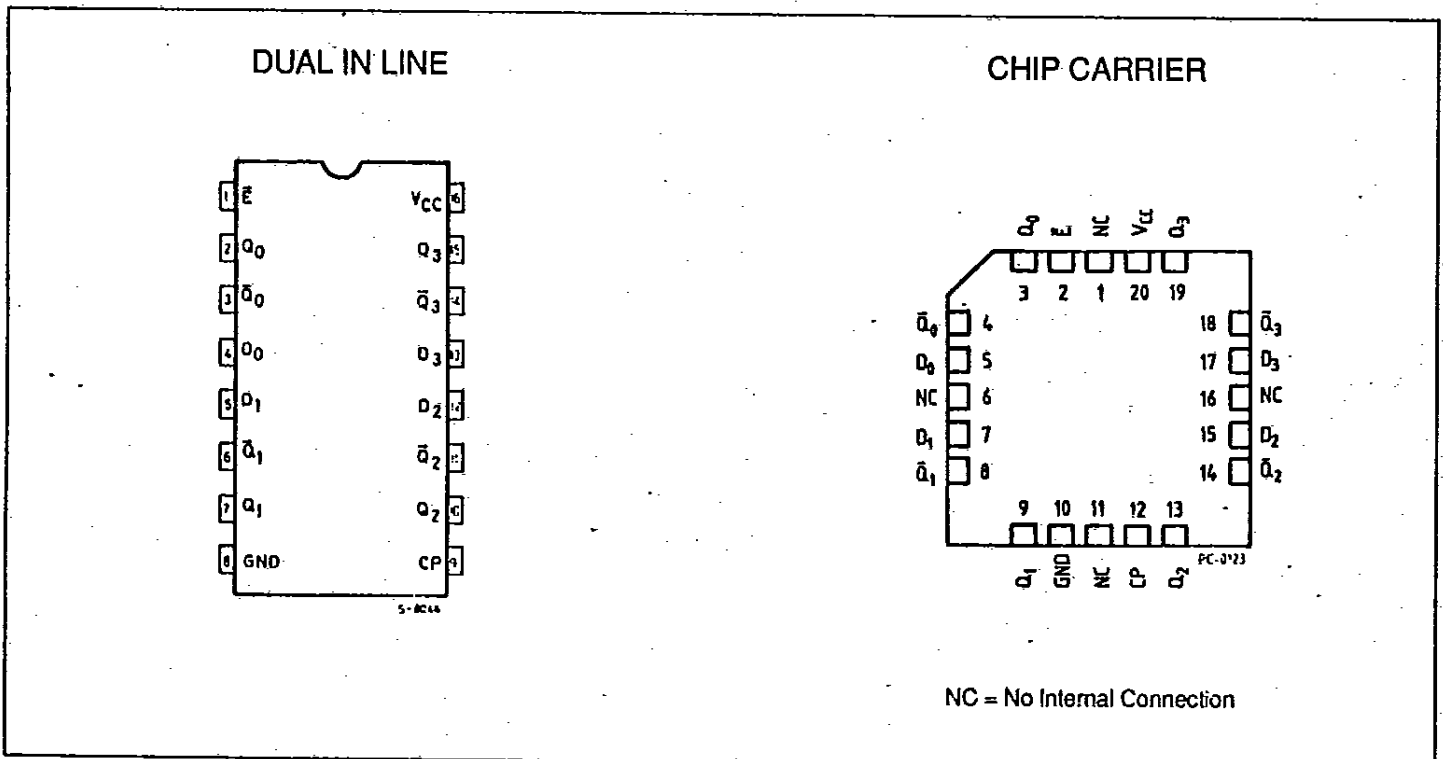

LOGIC SYMBOL AND LOGIC DIAGRAM

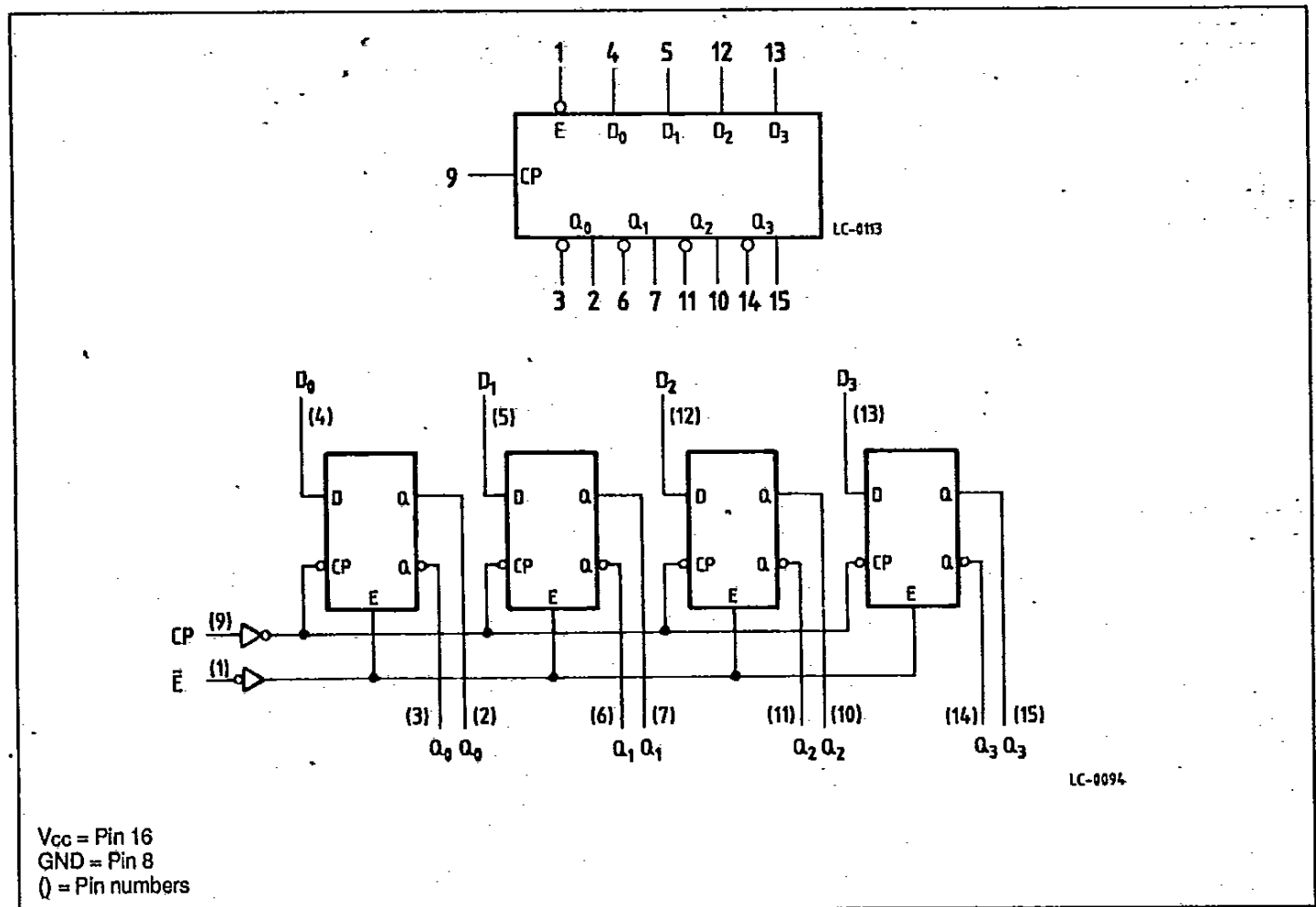

ABSOLUTE MAXIMUM RATINGS

Symbol	Parameter	Value	Unit
V_{CC}	Supply Voltage	- 0.5 to 7	V
V_I	Input Voltage, Applied to Input	- 0.5 to 15	V
V_O	Output Voltage, Applied to Output	- 0.5 to 10	V
I_I	Input Current, into Inputs	- 30 to 5	mA
I_O	Output Current, into Outputs	60	mA

Stresses in excess of those listed under "Absolute Maximum Ratings" may cause permanent damage to the device. This is a stress rating only and functional operation of the device at these or any other conditions in excess of those indicated in the operational sections of this specification is not implied. Exposure to absolute maximum rating conditions for extended periods may affect device reliability.

GUARANTEED OPERATING RANGE

Part Numbers	Supply Voltage			Temperature
	Min.	Typ.	Max.	
T74LS379XX	4.75 V	5.0 V	5.25 V	0 °C to + 70 °C

XX = package type.

FUNCTIONAL DESCRIPTION

The LS379 consist of four edge-triggered D-type flip-flops with individual D inputs and Q outputs. The Clock (CP) and Enable (\bar{E}) inputs are common to all flip-flops.

When the \bar{E} input is HIGH, the register will retain the present data independent of the CP input.

TRUTH TABLE

\bar{E}	CP	D_n	Q_n	\bar{Q}_n
H	\downarrow	X	No change	No Change
L	\downarrow	H	H	L
L	\downarrow	L	L	H

H = HIGH Voltage Level
L = LOW Voltage Level
X = Don't Care

DC CHARACTERISTICS OVER OPERATING TEMPERATURE RANGE

Symbol	Parameter	Limits			Test Condition (note 1)	Unit
		Min.	Typ. (*)	Max.		
V_{IH}	Input HIGH Voltage	2.0			Guaranteed Input HIGH Voltage for All Inputs	V
V_{IL}	Input LOW Voltage			0.8	Guaranteed Input LOW Voltage for All Inputs	V
V_{CD}	Input Clamp Diode Voltage		-0.65	-1.5	$V_{CC} = \text{MIN}$, $I_{IN} = -18 \text{ mA}$	V
V_{OH}	Output HIGH Voltage	2.7	3.4		$V_{CC} = \text{MIN}$, $I_{OH} = -400 \mu\text{A}$ $V_{IN} = V_{IH}$ or V_{IL} per Truth Table	V
V_{OL}	Output LOW Voltage		0.25	0.4	$I_{OL} = 4.0 \text{ mA}$	V
			0.35	0.5	$I_{OL} = 8.0 \text{ mA}$	V
I_{IH}	Input HIGH Current			20	$V_{CC} = \text{MAX}$, $V_{IN} = 2.7 \text{ V}$	μA
	Input HIGH Current at MAX Input Voltage E, D_0 - D_3 , CP			0.1	$V_{CC} = \text{MAX}$, $V_{IN} = 7.0 \text{ V}$	mA
I_{IL}	Input LOW Current E, D_0 - D_3 , CP			-0.4	$V_{CC} = \text{MAX}$, $V_{IN} = 0.4 \text{ V}$	mA
I_{OS}	Output Short Circuit Current (note 2)	-20		-100	$V_{CC} = \text{MAX}$, $V_{OUT} = 0 \text{ V}$	mA
I_{CC}	Power Supply Current		11	16	$V_{CC} = \text{MAX}$	mA

Notes : 1. Conditions for testing, not shown in the Table, are chosen to guarantee operation under "worst case" conditions.
2. Not more than one output should be shorted at a time.
(*) Typical values are at $V_{CC} = 5.0 \text{ V}$, $T_A = 25 \text{ }^\circ\text{C}$.

AC CHARACTERISTICS : $T_A = 25 \text{ }^\circ\text{C}$

Symbol	Parameter	Limits			Test Conditions	Unit
		Min.	Typ.	Max.		
t_{PLH}	CP to Output		17	27	Fig. 1 $V_{CC} = 5.0 \text{ V}$ $C_L = 15 \text{ pF}$	ns
t_{PHL}	CP to Output		18	27		ns
f_{MAX}	Maximum Clock Frequency	30	40			MHz

Symbol	Parameter	Limits			Test Conditions	Unit
		Min.	Typ.	Max.		
t_s	Set-up Time, Data to Clock (HIGH or LOW)	20			Fig. 1 $V_{CC} = 5.0\text{ V}$	ns
t_h	Hold Time, Data to Clock (HIGH or LOW)	5				ns
t_s	Set-up Time, Enable to Clock	30				ns
t_h	Hold Time, Enable to Clock	5				ns
t_{wCP}	Minimum Clock Pulse Width	17	10			ns

AC WAVEFORMS

Figure 1 : Clock to Output Delays, Clock Pulse Width, Frequency, Set-up and Hold Times Data, Enable to Clock.

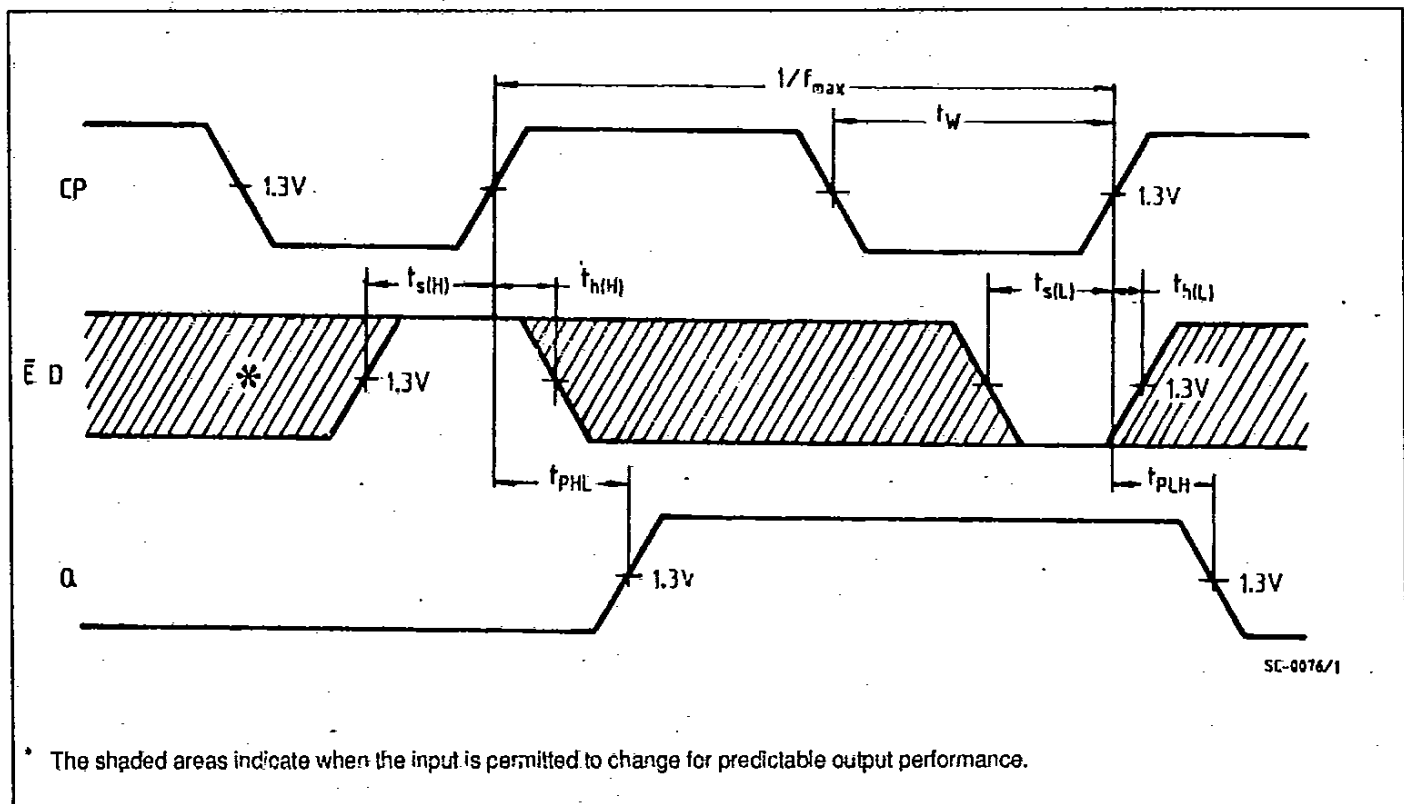

DEFINITION OF TERMS :

SET-UP TIME (t_s)- is defined as the minimum time required for the correct logic level to be present at the logic input prior to the clock transition from LOW to HIGH in order to be recognized and transferred to the outputs.

HOLD-TIME (t_h)- is defined as the minimum time following the clock transition from LOW to HIGH that the logic level must be maintained at the input in order to ensure continued recognition. A negative HOLD TIME indicates that the correct logic level may be released prior to the clock transition from LOW to HIGH and still be recognized.