

FEATURES

- Single Video Line Driver Chip
- $R_L=150\ \Omega$ (75 Ω Back-Terminated Cable)
- Power-Down Standby Mode
- Tiny 2.9 x 1.6 mm 6-Lead SOT23 Package
- Low Power Dissipation: 32 mW
- Flat Response $f_{IN} = 100\ \text{kHz}$ to 10 MHz (typical)
- Single +5 Volt Power Supply

APPLICATIONS

- Digital Video Disk
- Video Line Driver for Encoders
- Digital Video Tape Recorders
- Video Cassette Recorders
- PC Multimedia
- Consumer Video

GENERAL DESCRIPTION

The SPT9404 is a single video line driver chip that takes a standard video signal as an analog input and provides a buffered analog output for driving a 150 Ω load (75 Ω back-terminated cable). The standard video input signal (1 V_{P-P}) is typically amplified 6 dB using external components to produce a 2 V_{P-P} into an AC-coupled 150 Ω load. (See the typical interface circuit diagram.)

The SPT9404 features a standby mode which draws only 96 μW of power. Nominal power dissipation (no input) is typically 32 mW. It requires a single +5 V supply, operates over the commercial temperature range (0 to +70 $^{\circ}\text{C}$) and is available in a tiny surface mount (2.9 x 1.6 mm) 6-lead SOT-23 package.

BLOCK DIAGRAM

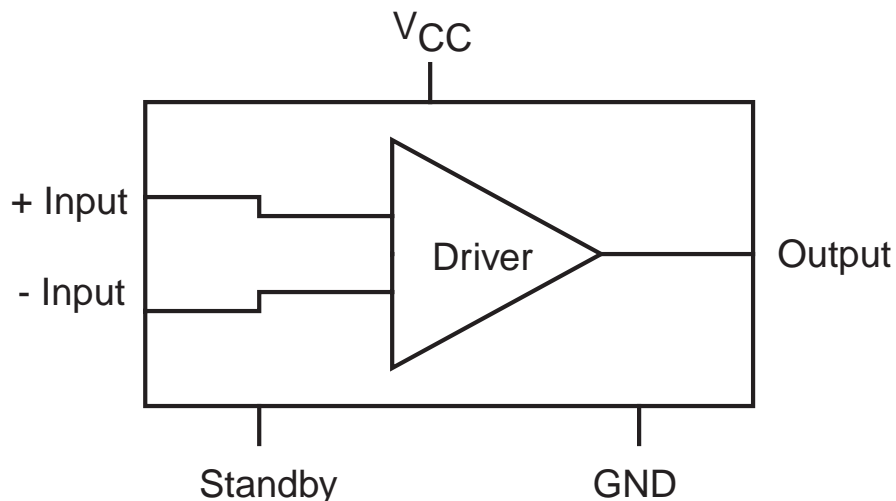

ABSOLUTE MAXIMUM RATINGS (Beyond which damage may occur)⁽¹⁾ 25 °C

Supply Voltages

V_{CC}+6.0 V

Maximum Power Dissipation

P_D 150 mW

Thermal Impedance (T_A=+25 °C and above)

θ_{CA} 1.2 mW/°C

Temperature

Operating Temperature 0 to +70 °C

Storage Temperature -55 to +150 °C

Note: 1. Operation at any Absolute Maximum Rating is not implied. See Electrical Specifications for proper nominal applied conditions in typical applications.

ELECTRICAL SPECIFICATIONS

T_A = +25 °C, V_{CC} = +5.0 V, V_{IN} = 1.0 V_{P-P} video signal, voltage gain of +2, R_L = 150 Ω, unless otherwise specified.

PARAMETERS	TEST CONDITIONS	TEST LEVEL	SPT9404			UNITS
			MIN	TYP	MAX	
Power Supply						
Supply Current (I _{CC})	No Input	I		6.3	8.5	mA
V _{CC} Voltage		IV	4.5	5.0	5.5	V
Power Dissipation		I		31.5	42.5	mW
Standby Current	Pin 1 Grounded	I		24	50	μA
Standby Power Dissipation	Pin 1 Grounded	I		96	250	μW
Digital Input						
Digital Input (Low)	Standby Pin 1	I	0.0	0.1	0.3	V
Digital Input (High)	Standby Pin 1	I	1.8	2.0	V _{CC}	V
Dynamic Performance						
Voltage Gain	f _{IN} = 1.0 MHz	I	5.7	6.0	6.3	dB
Total Harmonic Distortion	f _{IN} = 1.0 kHz	I		0.2	1.0	%
Open Loop Gain		V		40		dB
Bandwidth		V		20		MHz
Slew Rate		V		70		V/μs
Frequency Response	f _{IN} = 1 to 5 MHz	V		0.0		dB
Voltage Output Maximum (V _{OM})		I	1.0	1.2		V _{RMS}

TEST LEVEL CODES

All electrical characteristics are subject to the following conditions:

All parameters having min/max specifications are guaranteed. The Test Level column indicates the specific device testing actually performed during production and Quality Assurance inspection. Any blank section in the data column indicates that the specification is not tested at the specified condition.

TEST LEVEL

I
II
III
IV
V
VI

TEST PROCEDURE

100% production tested at the specified temperature.
100% production tested at T_A = +25 °C, and sample tested at the specified temperatures.
QA sample tested only at the specified temperatures.
Parameter is guaranteed (but not tested) by design and characterization data.
Parameter is a typical value for information purposes only.
100% production tested at T_A = +25 °C. Parameter is guaranteed over specified temperature range.

Figure 1 - Typical Interface Circuit

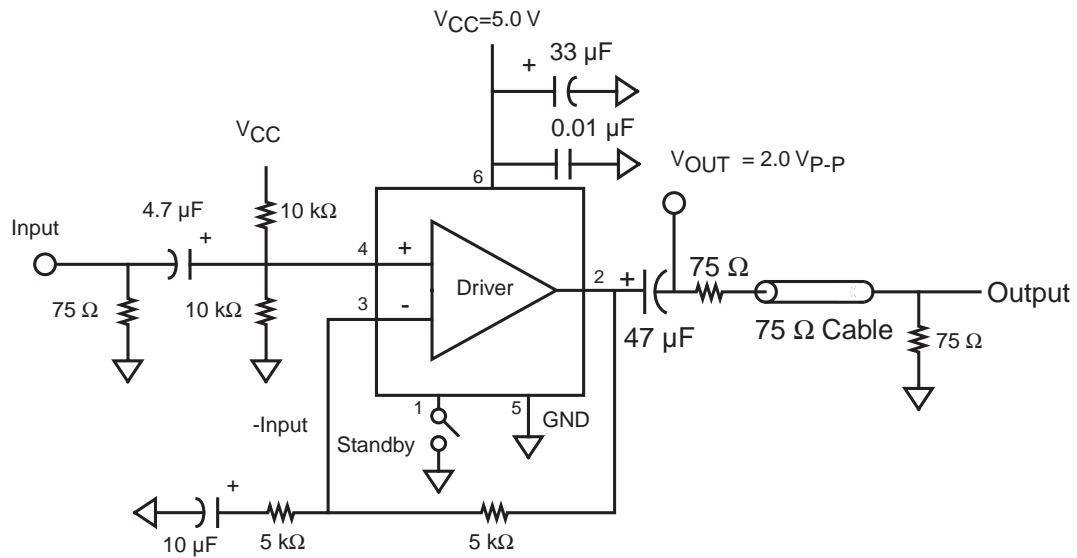

PACKAGE OUTLINE

6-Lead SOT23

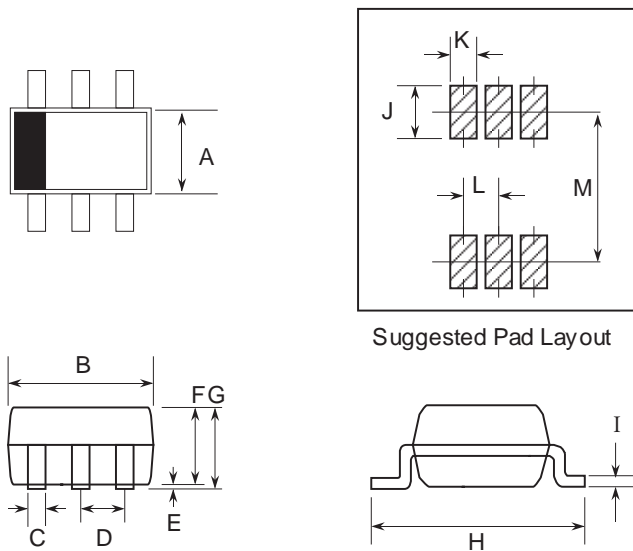

SYMBOL	INCHES		MILLIMETERS	
	MIN	MAX	MIN	MAX
A	0.055	0.071	1.4	1.8
B	0.106	0.122	2.7	3.1
C	0.008	0.016	0.2	0.4
D	0.037 typ		0.95 typ	
E	0.000	0.004	0.0	0.1
F	0.035	0.051	0.9	1.3
G		0.071 max		1.4 max
H	0.098	0.122	2.5	3.1
I	0.001	0.009	0.03	0.23
J	0.039 typ		1.0 typ	
K	0.028 typ		0.7 typ	
L	0.037 typ		0.95 typ	
M	0.094 typ		2.4 typ	

PIN ASSIGNMENTS

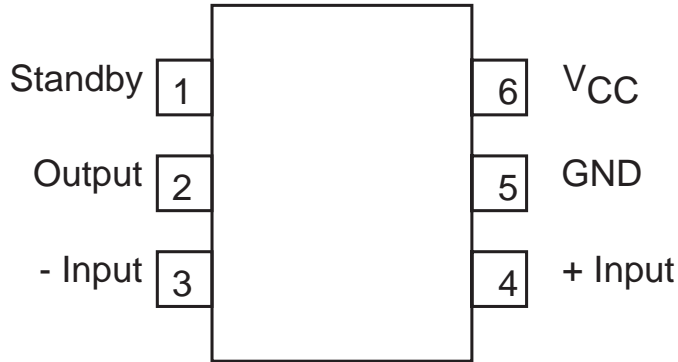

PIN FUNCTIONS

Name	Function
- Input	Inverting Signal Input (typically 1 V _{P-P} , AC coupled)
+ Input	Non-Inverting Signal Input (typically 1 V _{P-P} , AC coupled)
Output	Buffered Output (typically 2.0 V _{P-P} , R _L = 150 Ω, AC coupled)
Standby	Power Down Standby Mode Select (Low = Standby, Internal Pull-Up)
V _{CC}	+5.0 V Supply
GND	Ground

ORDERING INFORMATION

PART NUMBER	TEMPERATURE RANGE	PACKAGE TYPE
SPT9404SCL	0 to +70 °C	6-Lead SOT23

DISCLAIMER

FAIRCHILD SEMICONDUCTOR RESERVES THE RIGHT TO MAKE CHANGES WITHOUT FURTHER NOTICE TO ANY PRODUCTS HEREIN TO IMPROVE RELIABILITY, FUNCTION OR DESIGN. FAIRCHILD DOES NOT ASSUME ANY LIABILITY ARISING OUT OF THE APPLICATION OR USE OF ANY PRODUCT OR CIRCUIT DESCRIBED HEREIN; NEITHER DOES IT CONVEY ANY LICENSE UNDER ITS PATENT RIGHTS, NOR THE RIGHTS OF OTHERS.

LIFE SUPPORT POLICY

FAIRCHILD'S PRODUCTS ARE NOT AUTHORIZED FOR USE AS CRITICAL COMPONENTS IN LIFE SUPPORT DEVICES OR SYSTEMS WITHOUT THE EXPRESS WRITTEN APPROVAL OF THE PRESIDENT OF FAIRCHILD SEMICONDUCTOR CORPORATION. As used herein:

1. Life support devices or systems are devices or systems which, (a) are intended for surgical implant into the body, or (b) support or sustain life, and whose failure to perform, when properly used in accordance with instructions for use provided in the labeling, can be reasonably expected to result in a significant injury to the user.
2. A critical component is any component of a life support device or system whose failure to perform can be reasonably expected to cause the failure of the life support device or system, or to affect its safety or effectiveness.