

ML7xx45 SERIES

1310nm InGaAsP FP LASER DIODES

Notice: Some parametric limits are subject to change.

**TYPE
NAME****ML720J45S , ML720K45S, ML720Y45S
ML725B45F , ML725C45F****DESCRIPTION**

ML7XX45 series are InGaAsP laser diodes which provide a stable, single transverse mode oscillation with emission wavelength of 1310nm and standard continuous light output of 5mW.

ML7XX45 are hermetically sealed devices having the photo diode for optical output monitoring. This is suitable for such applications as FTTH (Fiber to the Home) and ~ 1Gbps Ethernet / Fiber channel systems.

FEATURES

- 1310nm typical emission wavelength, FP-LDs
- Low threshold current, low operating current
- Wide temperature range operation (Tc=-40 to 85deg.C)
- φ5.6mm TO-CAN package
Flat window cap : ML720J45S, ML725B45F
Ball lens cap : ML720K45S, ML725C45F, ML720Y45S

APPLICATION

- ~155Mbps FTTH system
- ~1Gbps Ethernet , Fiber channel

ABSOLUTE MAXIMUM RATINGS

Symbol	Parameter	Conditions	Rated	Unit
Po	Light output power	CW	10[7]	mW
VRL	Laser reverse voltage	-	2	V
VRD	PD reverse voltage	-	20	V
IFD	PD forward current	-	2	mA
Tc	Operation temperature	-	-40 to +85	deg.C
Tstg	Storage temperature	-	-40 to +100	deg.C

ELECTRICAL/OPTICAL CHARACTERISTICS(Tc=25°C)

Symbol	Parameter	Test Conditions	Min.	Typ.	Max.	Unit	
Ith	Threshold current	CW	3	5	15	mA	
Iop	Operation current	CW, Po=5mW	10	20	35	mA	
Vop	Operating voltage	CW, Po=5mW	---	1.1	1.5	V	
η	Slope efficiency	CW, Po=5mW	0.3[0.2]	0.4[0.3]	0.7[0.5]	mW/mA	
λc	Center wavelength	CW, Po=5mW	1290	1310	1330	nm	
Δλ	Spectral Width	CW, Po=5mW,RMS(-20dB)	---	1	2	nm	
θ	Beam divergence angle(parallel)	CW, Po=5mW	---	25[11]	---	deg.	
θ ⊥	Beam divergence angle(perpendicular)	CW, Po=5mW	---	30[11]	---	deg.	
tr,tf	Rise and Fall time (10%-90%)	Ib=Ith,Po=5mW,10-90%	---	0.3	0.7	nsec	
Im	Monitor Current (PD)	CW, Po=5mW, VRD=1V,	0.1	0.5	0.9	mA	
Id	Dark Current (PD)	VRD=10V	---	---	0.1	μA	
Ct	Capacitance (PD)	VRD=10V, f=1MHz	---	10	20	pF	
Pf(Note2)	Fiber Coupling characteristics at peak coupling<3>	CW, PL=5mW,S110/125	0.4	0.8	---	mW	
Df(Note2)		CW, PL=5mW,S110/125	ML720K45S	5.0	5.8	6.2	mm
			ML720Y45S	6.0	6.5	7.0	

Note : <1> [] applied to the lens cap type.

Note : <2> Pf,Df are applied to the ball lens type.

Note : <3> Df is a distance between reference plane of the base to the fiber.

MITSUBISHI LASER DIODES
ML7xx45 SERIES
 1310nm InGaAsP FP LASER DIODES

OUTLINE DRAWINGS

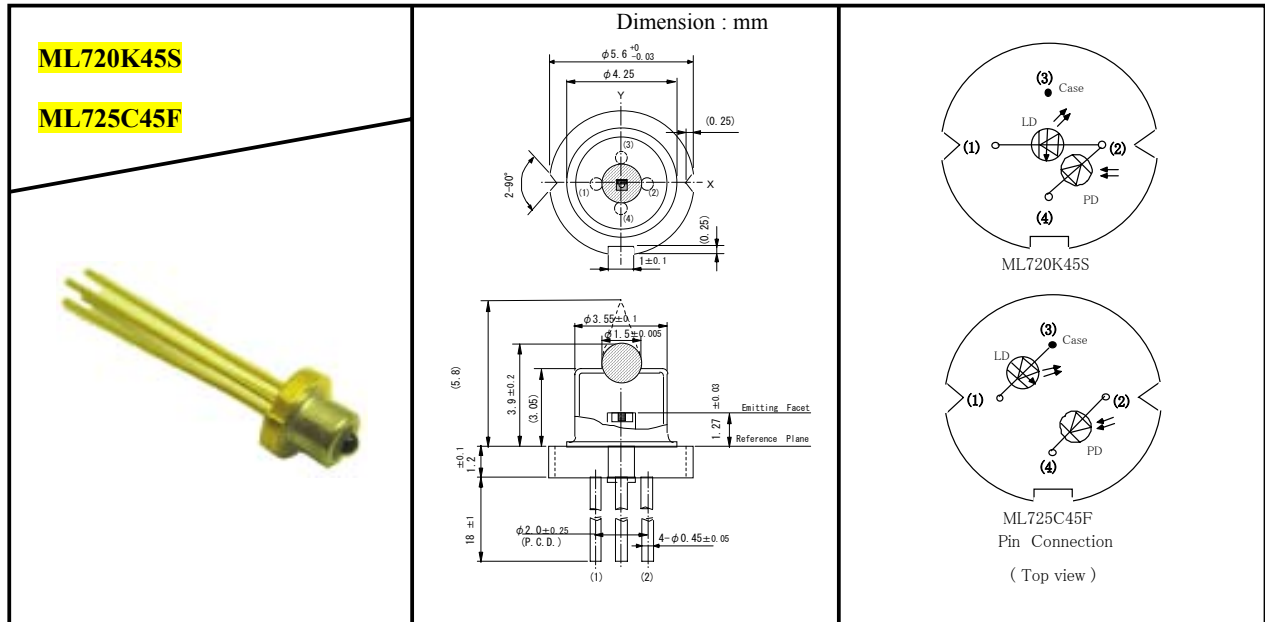
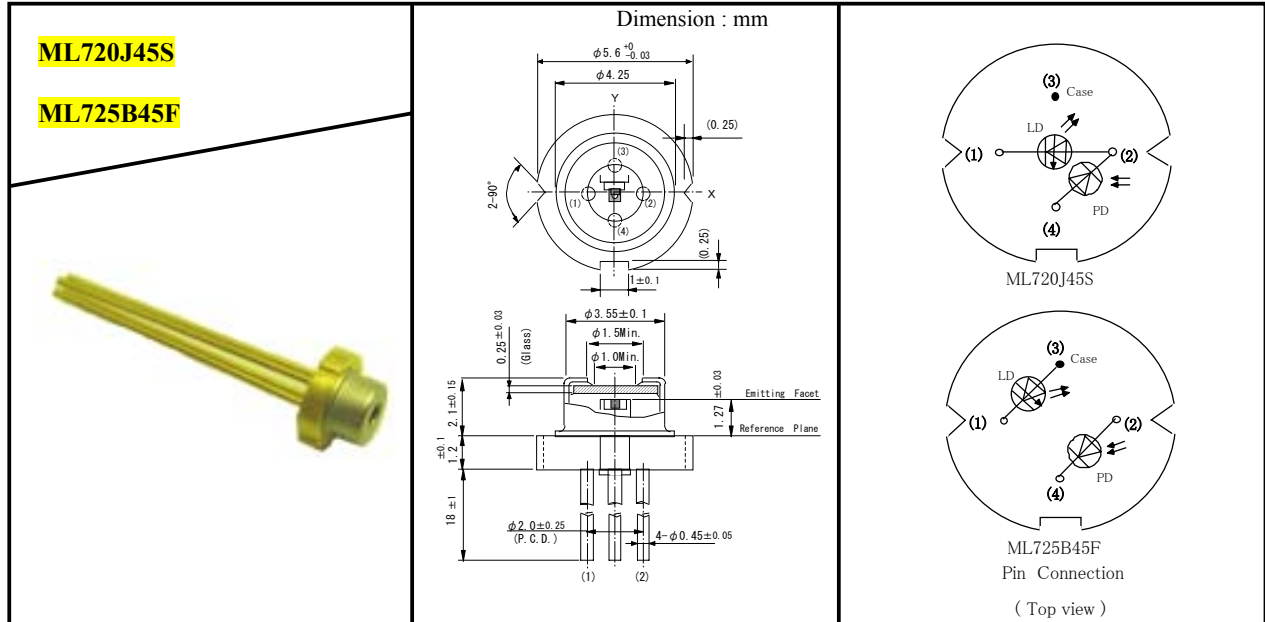

MITSUBISHI LASER DIODES
ML7xx45 SERIES
 1310nm InGaAsP FP LASER DIODES

OUTLINE DRAWINGS

