

MITSUBISHI LASER DIODES
ML7XX11 SERIES
 InGaAsP DFB LASER DIODES

Notice : Some parametric limits are subject to change

| | |
|----------------------|--|
| TYPE NAME | ML725B11F/ML720J11S ML725AA11F / ML720AA11S ML725J11F / ML720L11S |
|----------------------|--|

DESCRIPTION

ML7XX11series are DFB (Distributed Feedback) laser diodes emitting light beam around 1310nm. They are well suited for light source in long distance digital transmission system. They are hermetically sealed devices with the photo diode for optical output monitoring.

APPLICATION

· ~1.25Gbps digital transmission system

FEATURES

- Homogeneous grating (AR/HR facet coating) structure DFB
- Wide temperature range operation (-40 to 85°C)
- Low threshold current (typical 6mA)
- High speed response (typical 0.1nsec)
- φ5.6mm TO-CAN package
- Flat window cap, Ball lens cap, or Aspherical lens cap

ABSOLUTE MAXIMUM RATINGS

| Symbol | Parameter | Conditions | Ratings | Unit |
|-----------------|-------------------------------|------------|-------------|------|
| Po | Light output power | CW | 10 | mW |
| If | Forward current (Laser diode) | --- | 150 | mA |
| V _{RL} | Reverse voltage (Laser diode) | --- | 2 | V |
| V _{RD} | Reverse voltage (Photo diode) | --- | 20 | V |
| I _{FD} | Forward current (Photo diode) | --- | 2 | mA |
| Tc | Case temperature | --- | -40 to +85 | °C |
| Tstg | Storage temperature | --- | -40 to +100 | °C |

ELECTRICAL/OPTICAL CHARACTERISTICS (Tc=25°C otherwise specified)

[Flat window cap : ML725B11F / ML720J11S]

| Symbol | Parameter | Test conditions | Min. | Typ. | Max. | Unit |
|--------------------------------|---------------------------------------|--|------|------|------|-------|
| I _{th} | Threshold current | CW | --- | 6 | 12 | mA |
| | | CW, Tc=85°C | --- | 30 | 40 | |
| I _{op} | Operation current | CW, Po=5mW | --- | 16 | 30 | mA |
| | | CW, Po=5mW, Tc=85°C | --- | 50 | 75 | |
| V _{op} | Operating voltage | CW, Po=5mW | --- | 1.1 | 1.5 | V |
| η | Slope efficiency | CW, Po=5mW | 0.3 | 0.5 | --- | mW/mA |
| λ _p | Peak wavelength | CW, Po=5mW | 1290 | 1310 | 1330 | nm |
| θ // | Beam divergence angle (parallel) | CW, Po=5mW | --- | 25 | 35 | deg. |
| θ ⊥ | Beam divergence angle (perpendicular) | CW, Po=5mW | --- | 30 | 40 | deg. |
| SMSR | Side mode suppression ratio | CW, Po=5mW Tc= - 40 to +85°C | 35 | 40 | --- | dB |
| t _r ,t _f | Rise and Fall time | I _b =I _{th} , 20-80% <*> | --- | 0.1 | 0.2 | ns |
| I _m | Monitoring output current (PD) | CW, Po=5mW | 0.05 | 0.2 | --- | mA |
| I _d | Dark current (PD) | V _{RD} =5V | --- | --- | 0.1 | μA |
| C _t | Capacitance (PD) | V _{RD} =5V | --- | 10 | 20 | pF |

<*> Except influence of the 18mm lead.

MITSUBISHI LASER DIODES
ML7XX11 SERIES
 InGaAsP DFB LASER DIODES

Notice : Some parametric limits are subject to change

ELECTRICAL/OPTICAL CHARACTERISTICS (Tc=25°C otherwise specified)

[Ball lens cap ; ML725AA11F / ML720AA11S]

| Symbol | Parameter | Test conditions | Min. | Typ. | Max. | Unit |
|--------|--------------------------------|---------------------------------|------|------|------|-------|
| Ith | Threshold current | CW | --- | 6 | 12 | mA |
| | | CW, Tc=85°C | --- | 30 | 40 | |
| Iop | Operation current | CW, Po=5mW | --- | 16 | 30 | mA |
| | | CW, Po=5mW, Tc=85°C | --- | 50 | 75 | |
| Vop | Operating voltage | CW, Po=5mW | --- | 1.1 | 1.5 | V |
| η | Slope efficiency | CW, Po=5mW | 0.3 | 0.5 | --- | mW/mA |
| λp | Peak wavelength | CW, Po=5mW | 1290 | 1310 | 1330 | nm |
| SMSR | Side mode suppression ratio | CW, Po=5mW Tc= - 40 to +85°C | 35 | 40 | --- | dB |
| Pf | Fiber coupling power | CW, Po=5mW, SMF | 0.5 | 1.0 | --- | mW |
| Df | Focul length | CW, Po=5mW, SMF | 6.0 | 6.5 | 7.0 | mm |
| tr,tf | Rise and Fall time | Ib=Ith, 20-80% <*> | --- | 0.1 | 0.2 | ns |
| Im | Monitoring output current (PD) | CW, Po=5mW | 0.05 | 0.2 | --- | mA |
| Id | Dark current (PD) | V _{RD} =5V | --- | --- | 0.1 | μA |
| Ct | Capacitance (PD) | V _{RD} =5V | --- | 10 | 20 | pF |

<*> Except influence of the 18mm lead.

ELECTRICAL/OPTICAL CHARACTERISTICS (Tc=25°C otherwise specified)

[Aspherical lens cap ; ML725J11F / ML720L11S]

| Symbol | Parameter | Test conditions | Min. | Typ. | Max. | Unit |
|--------|--------------------------------|---------------------------------|------|------|------|-------|
| Ith | Threshold current | CW | --- | 6 | 12 | mA |
| | | CW, Tc=85°C | --- | 30 | 40 | |
| Iop | Operation current | CW, Po=5mW | --- | 16 | 30 | mA |
| | | CW, Po=5mW, Tc=85°C | --- | 50 | 75 | |
| Vop | Operating voltage | CW, Po=5mW | --- | 1.1 | 1.5 | V |
| η | Slope efficiency | CW, Po=5mW | 0.3 | 0.5 | --- | mW/mA |
| λp | Peak wavelength | CW, Po=5mW | 1290 | 1310 | 1330 | nm |
| SMSR | Side mode suppression ratio | CW, Po=5mW Tc= - 40 to +85°C | 35 | 40 | --- | dB |
| Pf | Fiber coupling power | CW, Po=5mW, SMF | 1.5 | 2.0 | --- | mW |
| Df | Focul length | CW, Po=5mW, SMF | 6.5 | 7.5 | 8.5 | mm |
| tr,tf | Rise and Fall time | Ib=Ith, 20-80% <*> | --- | 0.1 | 0.2 | ns |
| Im | Monitoring output current (PD) | CW, Po=5mW | 0.05 | 0.2 | --- | mA |
| Id | Dark current (PD) | V _{RD} =5V | --- | --- | 0.1 | μA |
| Ct | Capacitance (PD) | V _{RD} =5V | --- | 10 | 20 | pF |

<*> Except influence of the 18mm lead.

MITSUBISHI LASER DIODES
ML7XX11 SERIES
 InGaAsP DFB LASER DIODES

Notice : Some parametric limits are subject to change

OUTLINE DRAWINGS

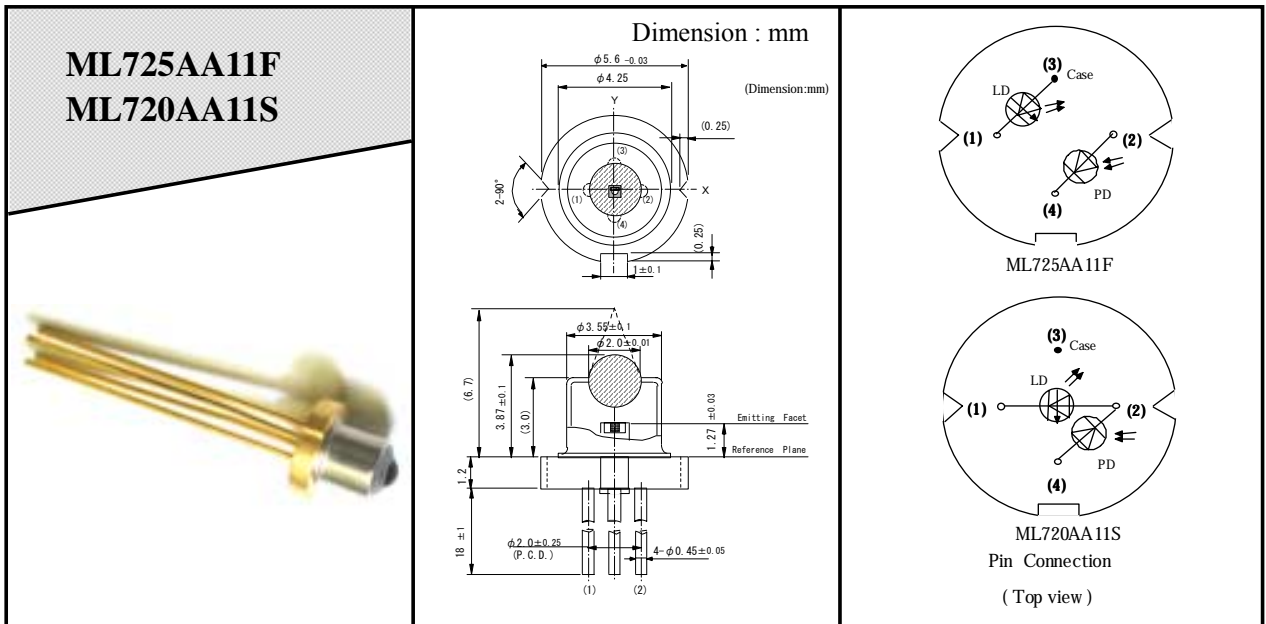
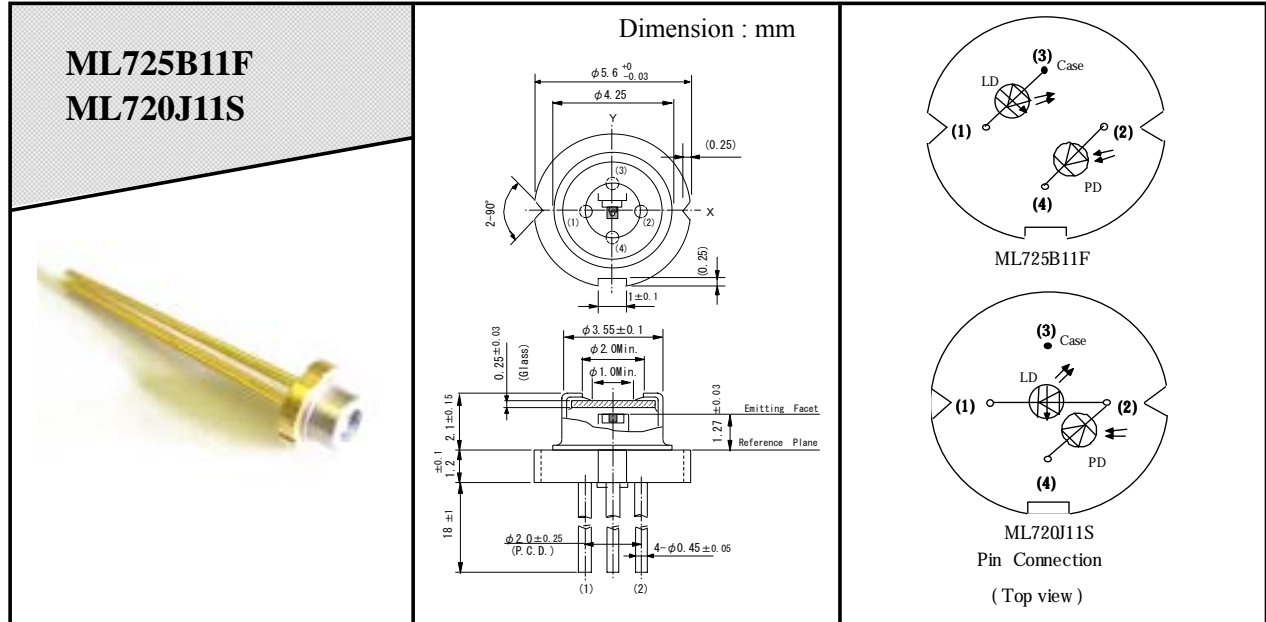

MITSUBISHI LASER DIODES
ML7XX11 SERIES
 InGaAsP DFB LASER DIODES

Notice : Some parametric limits are subject to change

OUTLINE DRAWINGS

