

OKI Semiconductor

FEDL7041-04

Issue Date: Mar. 2, 2006

ML7041

Audio CODEC

GENERAL DESCRIPTION

The ML7041 is a single-channel full duplex CODEC LSI device which performs mutual transcoding between the analog voice band signals ranging from 300 to 3400 Hz and the 64 kbps PCM serial data.

Provided with such functions as DTMF Tone generation, transmit/receive data gain control, side-tone path, and low-dropout regulator, the ML7041 is best suited for telephone terminals in digital wireless systems.

FEATURES

- Single 3 V power supply V_{DD} : 2.4 to 3.3 V
- Coding format: PCM μ -law/PCM A-law/14-bit linear mode selectable
- PCM interface timing: Long frame synchronous timing/short frame synchronous timing selectable
- Transmit/receive full-duplex operation
- Serial PCM transmission data rate: 64 to 2048 kbps
- Low power consumption
 - Operating mode: 15 mW typ. ($V_{DD} = 3.0$ V)
 - Power-down mode: 3 μ W typ. ($V_{DD} = 3.0$ V)
- Master clock frequency: 2.048 MHz (compatible with PCM shift clock)
- Analog output stage
 - 100 mW (differential type) amplifier output for driving receiver speaker:
Capable of driving an 8 Ω load.
 - 6.6 mW (single type) amplifier output for driving earphones speaker:
Capable of driving a 32 Ω load.
- Built-in two low-dropout regulators (150 mA \times 2)
- Built-in four general purpose drivers (150 mA \times 4)
- Transmit/receive mute, transmit/receive programmable gain control
- Built-in side tone path
- Built-in DTMF tone generator
- Transmit slope filter selectable
- I²C bus interface (MCU interface)
- Built-in transmit voice signal detector
- Package: 48-pin plastic TQFP (TQFP48-P-0707-0.50-K) (ML7041 TB)

BLOCK DIAGRAM

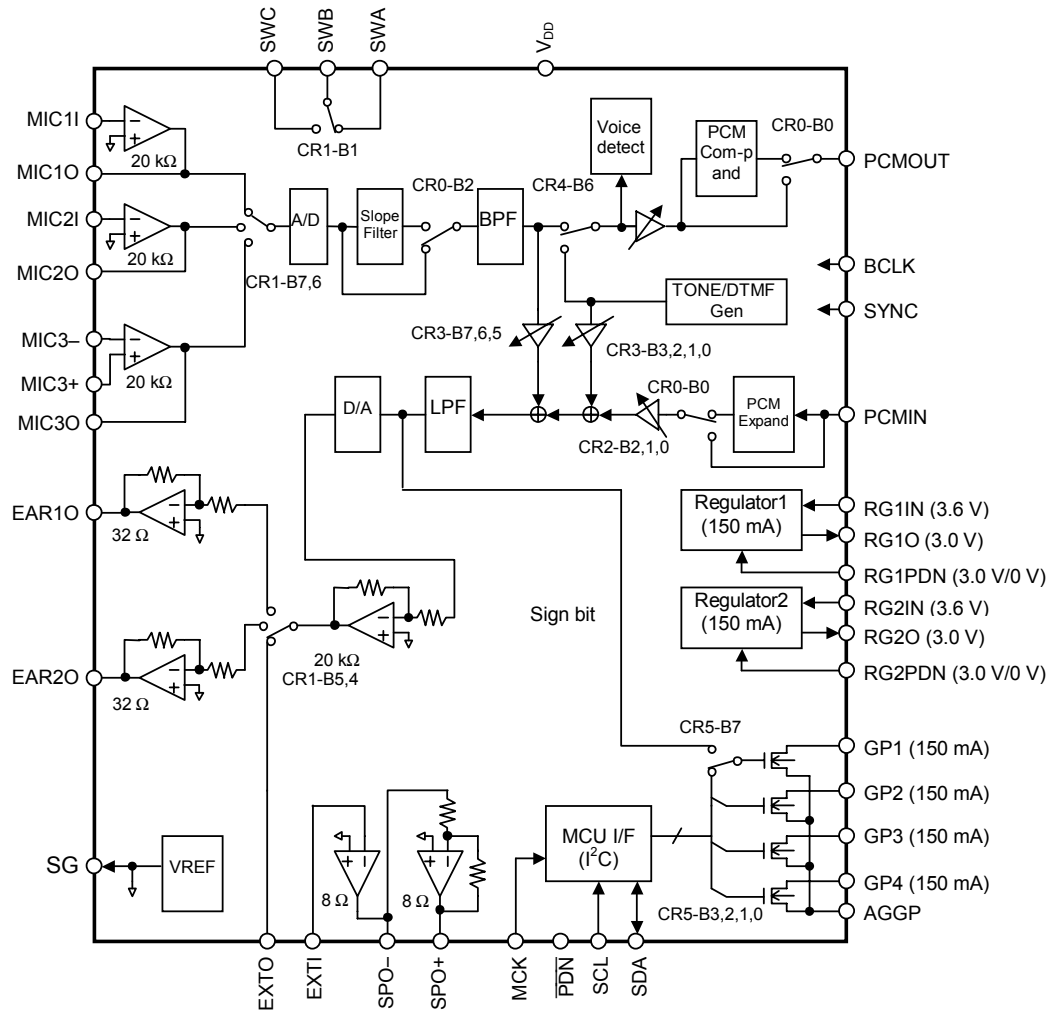

PIN CONFIGURATION (TOP VIEW)

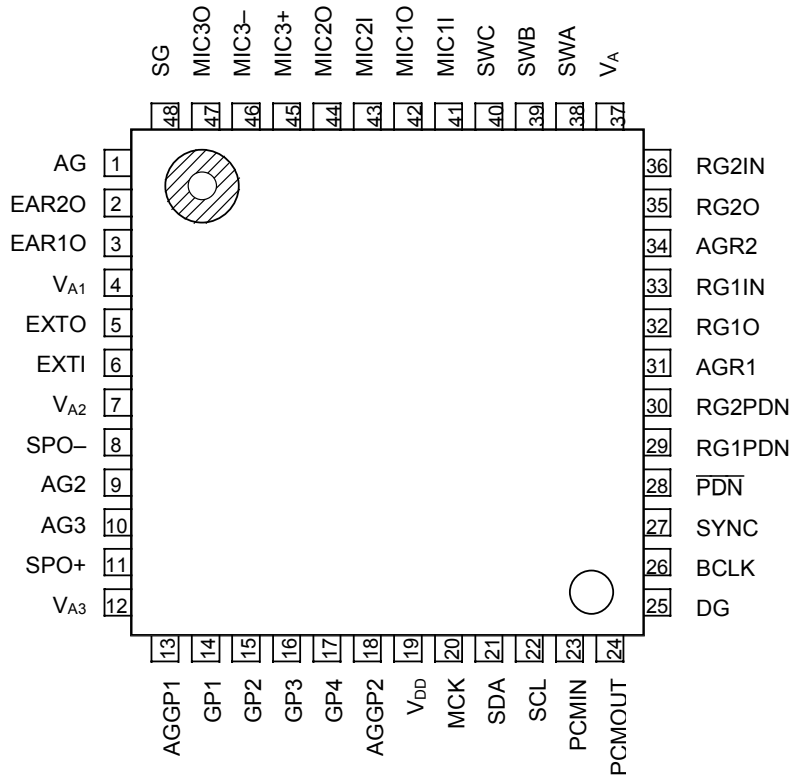

48-Pin Plastic TQFP

PIN DESCRIPTIONS

Pin	Symbol	Type	Description	State in power-down mode
1	AG	—	Analog ground (0 V)	—
2	EAR2O	O	Receive side voice amplifier output 2	High impedance
3	EAR1O	O	Receive side voice amplifier output 1	High impedance
4	V _{A1}	—	Analog power supply 1 (3.0 V)	—
5	EXTO	O	Receive side voice amplifier output	High impedance
6	EXTI	I	Receive side voice amplifier input	—
7	V _{A2}	—	Analog power supply 2 (3.0 V)	—
8	SPO–	O	Receive side voice amplifier output–	High impedance
9	AG2	—	Analog ground 2 (0 V)	—
10	AG3	—	Analog ground 3 (0 V)	—
11	SPO+	O	Receive side voice amplifier output+	High impedance
12	V _{A3}	—	Analog power supply 3 (3.0 V)	—
13	AGGP1	—	General purpose port ground 1 (0 V)	—
14	GP1	O	General purpose port 1 output (Open drain)	High impedance
15	GP2	O	General purpose port 2 output (Open drain)	High impedance
16	GP3	O	General purpose port 3 output (Open drain)	High impedance
17	GP4	O	General purpose port 4 output (Open drain)	High impedance
18	AGGP2	—	General purpose port ground 2 (0 V)	—
19	V _{DD}	—	Digital power supply (3.0 V)	—
20	MCK	I	Master clock input (2.048 MHz)	—
21	SDA	I/O	I ² C data input/output (Pull-up resistor required)	High impedance
22	SCL	I	I ² C shift clock input	—
23	PCMIN	I	PCM receive signal input	—
24	PCMOUT	O	PCM transmit signal output	“H”
25	DG	—	Digital ground (0 V)	—
26	BCLK	I	PCM data shift clock input	—
27	SYNC	I	PCM data shift sync signal input	—
28	$\overline{\text{PDN}}$	I	Power down control input	“L”
29	RG1PDN	I	Power down input for regulator 1 (3.0 V/0 V)	“L”
30	RG2PDN	I	Power down input for regulator 2 (3.0 V/0 V)	“L”
31	AGR1	—	Ground for regulator 1 (0 V)	—
32	RG1O	O	Regulator 1 output (3.0 V)	“L” (RG1PDN = “L”)
33	RG1IN	I	Regulator 1 power input (3.6 V)	—
34	AGR2	—	Ground for regulator 2 (0 V)	—
35	RG2O	O	Regulator 2 power output (3.0 V)	“L” (RG2PDN = “L”)
36	RG2IN	I	Regulator 2 input (3.6 V)	—
37	V _A	—	Analog power supply (3.0 V)	—
38	SWA	I/O	Analog switch A	—
39	SWB	I/O	Analog switch B	—
40	SWC	I/O	Analog switch C	—
41	MIC1I	I	Transmit side amplifier 1 inverting input	—
42	MIC1O	O	Transmit side amplifier 1 output	High impedance
43	MIC2I	I	Transmit side amplifier 2 inverting input	—
44	MIC2O	O	Transmit side amplifier 2 output	High impedance
45	MIC3+	I	Transmit side amplifier 3 non-inverting input	—
46	MIC3–	I	Transmit side amplifier 3 inverting input	—
47	MIC3O	O	Transmit side amplifier 3 output	High impedance
48	SG	O	Analog signal ground (1.4 V)	“L”

PIN AND FUNCTIONAL DESCRIPTIONS

MIC1I, MIC1O, MIC2I, MIC2O, MIC3-, MIC3+, MIC3-

Transmit analog inputs and outputs for transmit gain adjustment. Gains of input levels of the pins can be adjusted using external resistors.

MIC1I, MIC2I, and MIC3- are connected to the inverting inputs of the internal transmit amplifiers. MIC3+ is connected to the non-inverting input of the internal transmit amplifier 3. MIC1O, MIC2O, and MIC3O are connected to the internal transmit amplifier outputs. Analog input signals are controlled by the control register (CR1-B7, B6). Also, the amplifiers that are not being selected are deactivated and their outputs are put into high impedance state.

Refer to Figure 1 for gain adjustment.

EAR1O, EAR2O, EXTO, EXTI, SPO-, SPO+

Receive analog outputs and inputs for receive gain adjustment. EAR1O, EAR2O, and EXTO are the receive filter outputs. EAR1O and EAR2O can directly drive a 32 Ω load.

SPO+ and SPO- are differential analog signal outputs which can directly drive an 8 Ω load. The receive side signal outputs can be selected by CR1-B5 and CR1-B4. If the amplifiers connected to EAR1O and EAR2O are not being selected, the amplifiers are deactivated and their outputs are put into high impedance state. Gains of output levels of the pins can be adjusted using the external resistors. The power control is accomplished by CR0-B6. Refer to Figure 1.

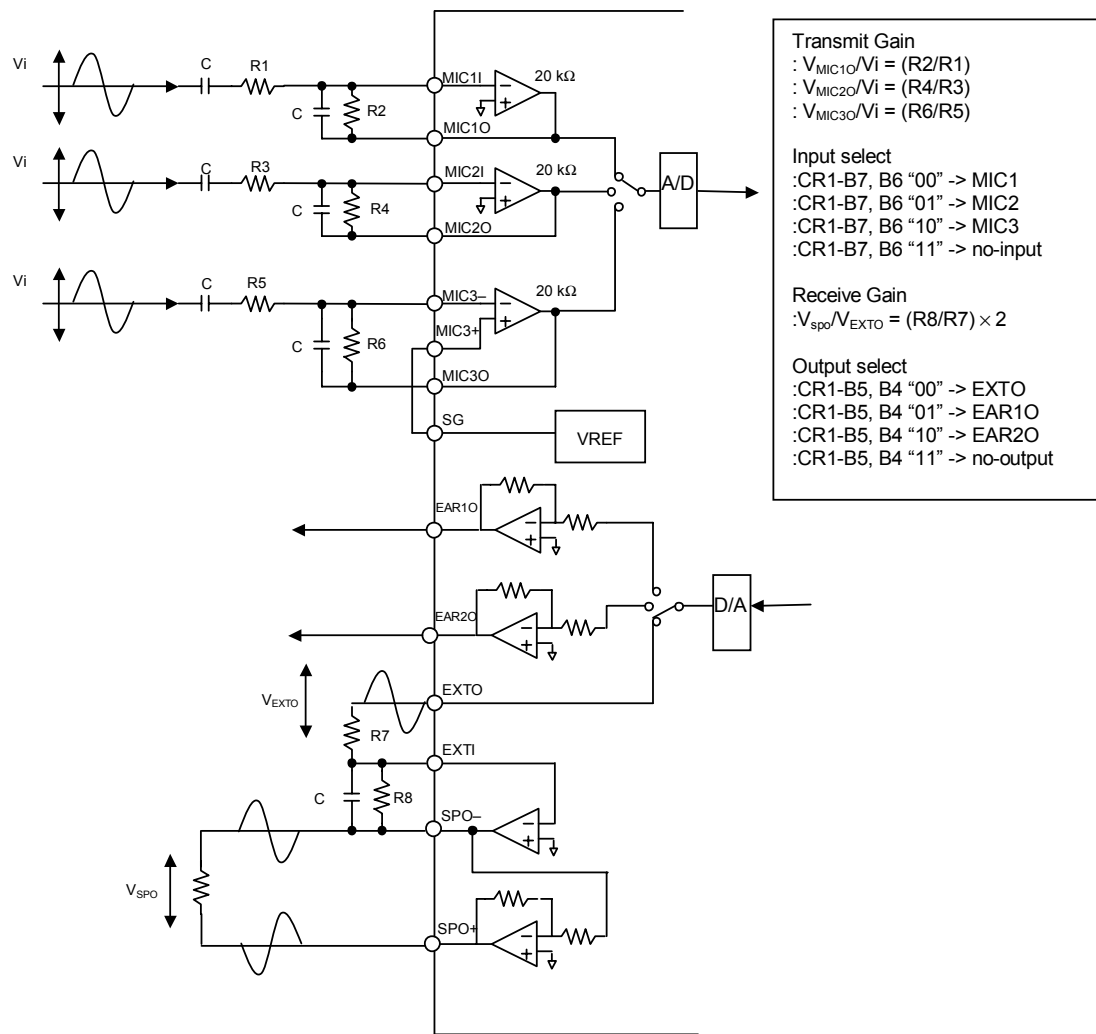

Figure 1 Analog Interface

SG

Analog signal ground.

The output voltage of this pin is approximately 1.4 V. Put the bypass capacitors 0.1 μ F ceramic type between this pin and GND to get the specified noise characteristics. During power-down, this output voltage is 0 V.

SWA, SWB, SWC

Used for an internal analog switch. The pin SWB is connected to the pin SWA or the pin SWC. This is controlled by CR1-B1.

RG1PDN, RG1IN, RG1O

Used for Regulator 1. The RG1PDN pin is a power down input. When set to “L”, the Regulator 1 changes to the power down state. Since the power down is controlled by a logical OR with CR5-B4 of the control register, set CR5-B4 to logic “0” when using this pin. The RG1IN pin is input to the Regulator 1. The RG1O pin is output from the Regulator 1, whose voltage is 3.0 V. A 1 μ F ceramic type bypass capacitor must be connected between the power input pin and GND, and a 10 μ F tantalum bypass capacitor must be connected from the output pin to GND.

RG2PDN, RG2IN, RG2O

Used for Regulator 2. The RG2PDN pin is a power down input. When set to “L”, the Regulator 2 changes to the power down state. Since the power down is controlled by a logical OR with CR5-B5 of the control register, set CR5-B5 to logic “0” when using this pin. The RG2IN pin is the input to the Regulator 2. The RG2O pin is the output from the Regulator 2, whose voltage is 3.0 V. A 1 μ F ceramic type bypass capacitor must be connected between the power input pin and GND, and a 10 μ F tantalum bypass capacitor must be connected from the output pin to GND.

Note1: The RG1O and RG2O outputs must not be used as the 3 V supply for the ML7041.

Note2: The RG1IN and RG2IN should be common near the device and supplied from the same power supply.

GP1, GP2, GP3, GP4

General purpose driver output. Each pin is controlled by CR5-B1 through CR5-B4. By selecting CR5-B7, the GP1 pin can be controlled by the receive side sign bit.

V_{DD}, V_A, V_{A1}, V_{A2}, V_{A3}

V_{DD} is the digital power supply. V_A, V_{A1}, V_{A2}, and V_{A3} are the analog power supply pins. Since these pins are separated in the device, connect them as close as possible on the PCB.

DG, AG, AG1, AG2, AG3, AGR1, AGR2, AGGP1, AGGP2

Ground. DG is the digital ground. AG, AG1, AG2, AG3, AGR1, AGR2, AGGP1 and AGGP2 are the analog ground. Since these pins are separated in the device, connect them as close as possible on the PCB.

PDN

Power down and reset control input.

When set to digital “L”, the device changes to the power down state and the control register is reset. Since the power down mode is controlled by a logical OR with CR0-B5 of the control register, set CR0-B5 to logic “0” when using this pin. The reset pulse width must be 200 ns or more. Be sure to reset the control register after turning on the power.

MCK

Master clock input.

The frequency must be 2.048 MHz. MCK can be asynchronous with SYNC and BCLK.

If a frequency of BCLK is 2.048 MHz, the BCLK can be shared with MCK.

BCLK

Shift clock input for the PCM data.

The frequency is set in the range of 64 kHz to 2048 kHz for A/ μ -law PCM data and set in the range of 128 kHz to 2048 kHz for linear code selection.

SYNC

8 kHz synchronous signal input for transmit and receive PCM data.

Synchronize this signal with BCLK signal. This signal is used to indicate the MSB of the PCM data stream.

PCMOUT

Transmit PCM data output. The PCM output signal is output from MSB, synchronously with the rising edges of BCLK and SYNC. Refer to Figure 2. This is a logic output pin so that external pull-up is not required. This pin outputs logic "L" except during effective PCM data bits, and outputs logic "H" during power-down.

PCMIN

Receive PCM data input.

The PCM input signal is shifted in on the falling edge of BCLK and is input from MSB.

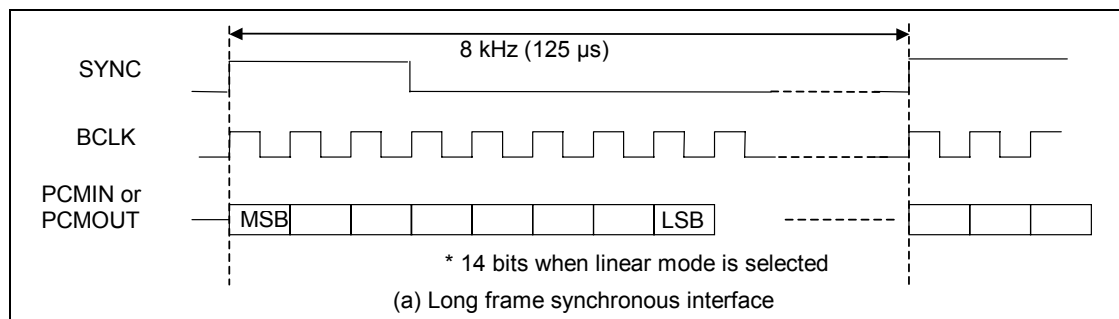

Refer to Figure 2.

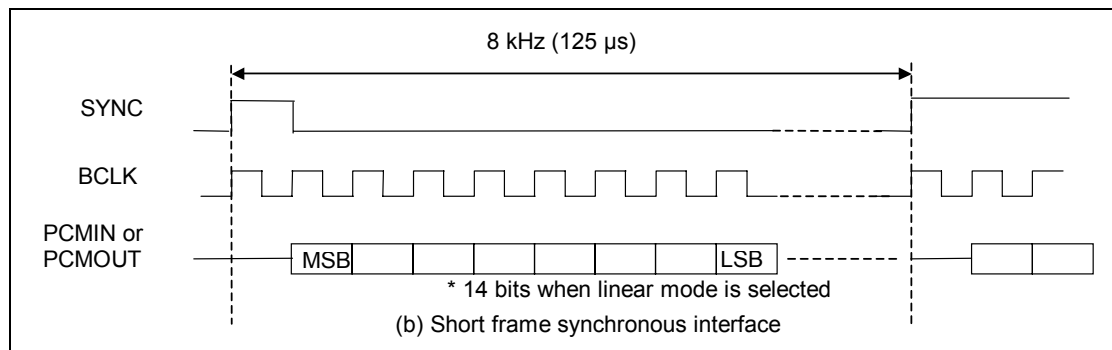

Figure 2 PCM Interface Basic Timing Diagram

SDA, SCL

SDA is the serial data input/output pin and SCL is the serial clock line input pin. A pull-up register of 1 to 10 kΩ is required for the SDA pin. The master clock is required when data is written or read.

Transfer format

The control register can be controlled according to the I²C bus transfer format.

The control register address is 3 bits long and the register data is 8 bits long. The methods of writing and reading of data are shown below.

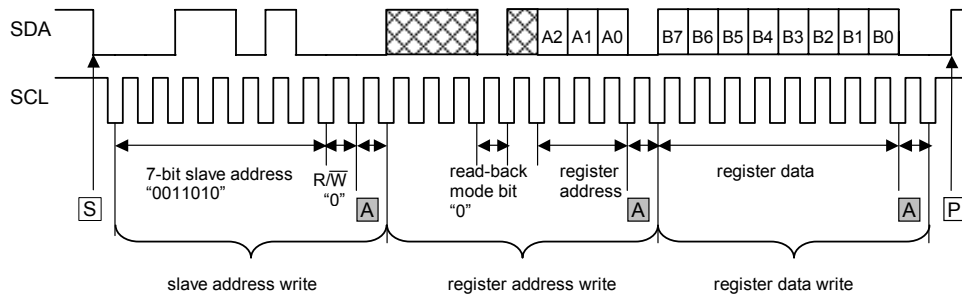

Figure 3 I²C Interface Write Timing

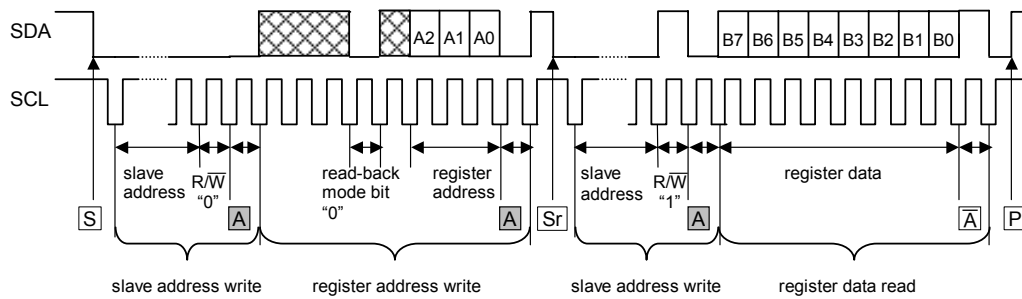

Figure 4 I²C Interface Read Timing: normal mode

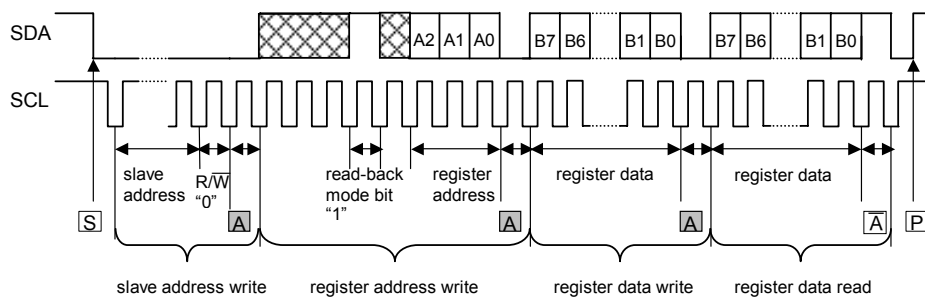

Figure 5 I²C Interface Read Timing: read-back mode

ML7041 Slave address "0011010"

- START condition
- STOP condition
- Repeated START condition
- Acknowledged (ML7041 drive SDA to "0")
- Not Acknowledged
- Don't care ("0" or "1")

Table 1 shows the register map.

Table 1 Control Register Map

Name	Address			Control and Detect Data								RW
	A2	A1	A0	B7	B6	B5	B4	B3	B2	B1	B0	
CR0	0	0	0	A/ μ SEL	SPOUT PON	PDN ALL	PDN TX	PDN RX	SLP	SLP SEL	LNR	R/W
CR1	0	0	1	MIC SEL1	MIC SEL0	SP SEL1	SP SEL0	SHORT FRAME	—	SW C/A	RX PAD	R/W
CR2	0	1	0	TX ON/OFF	TX GAIN2	TX GAIN1	TX GAIN0	RX ON/OFF	RX GAIN2	RX GAIN1	RX GAIN0	R/W
CR3	0	1	1	SIDE TONE GAIN2	SIDE TONE GAIN1	SIDE TONE GAIN0	TONE ON/OFF	TONE GAIN3	TONE GAIN2	TONE GAIN1	TONE GAIN0	R/W
CR4	1	0	0	DTMF/ OTHERS SEL	TONE SEND	—	TONE4	TONE3	TONE2	TONE1	TONE0	R/W
CR5	1	0	1	GP1 SEL CR/TONE	—	RG2PDN	RG1PDN	GP4C	GP3C	GP2C	GP1C	R/W
CR6	1	1	0	VOX ON/OFF	ON LVL1	—	—	—	—	—	—	R/W
CR7	1	1	1	VOX OUT	TX NOISE1	TX NOISE0	—	—	—	—	—	R

R/W: Read/Write enable R: Read only register

ABSOLUTE MAXIMUM RATINGS

Parameter	Symbol	Condition	Rating	Unit
Power Supply Voltage	V _{DD}	—	-0.3 to +4.6	V
Analog Input Voltage	V _{AIN}	—	-0.3 to V _{DD} +0.3	V
Digital Input Voltage	V _{DIN}	—	-0.3 to V _{DD} +0.3	V
Storage Temperature	T _{STG}	—	-55 to +150	°C
Operating Junction Temperature *	T _{Jmax}	—	+150	°C

RECOMMENDED OPERATING CONDITIONS

Parameter	Symbol	Condition	Min.	Typ.	Max.	Unit
Power Supply Voltage	V _{DD}	—	2.4	—	3.3	V
Operating Temperature	T _a	—	-40	+25	+85	°C
Operating Junction Temperature (Average) *	T _{Jmaxa}	—	—	—	105	°C
Input High Voltage	V _{IH}	all digital input pins	0.7 × V _{DD}	—	V _{DD}	V
Input Low Voltage	V _{IL}	all digital input pins	0	—	0.20 × V _{DD}	V
Digital Input Rise Time	t _{ir}	all digital input pins	—	—	50	ns
Digital Input Fall Time	t _{if}	all digital input pins	—	—	50	ns
Digital Output Load	C _{DL}	all digital output pins	—	—	100	pF
Bypass Capacitor for SG	C _{SG}	Between SG and AG	0.1	—	—	μF
Master Clock Frequency	F _{MCK}	MCK	-0.01%	2.048	+0.01%	MHz
Bit Clock Frequency	F _{BCK1}	BCLK (A/μ-law)	64	—	2048	kHz
	F _{BCK2}	BCLK (linear)	128	—	2048	kHz
Synchronous Signal Frequency	F _{SYNC}	SYNC	—	8.0	—	kHz
Clock Duty Ratio	D _{CLK}	MCK, BCLK	40	50	60	%
Sync Pulse Setting Time	T _{SB}	SYNC → BCLK	-100	—	100	ns
	T _{BS}	BCLK → SYNC	100	—	—	ns
Synchronous Signal Width	t _{WS}	SYNC	1BCLK	—	100	μs

* The device should be used in such a way that T_{Jmax} (average) is less than 105°C.

T_{Jmax} is given by the equation:

$$T_{Jmax} = P \times \theta_{ja} + T_a$$

where P = Power dissipation (W)

A 48-pin TQFP package is used.

$\theta_{ja} = 195^\circ\text{C}$ (not mounted on a PCB, in still-air-ambient)

$\theta_{ja} = 156^\circ\text{C}$ (mounted on a typical PCB, in still-air-ambient)

For more details, refer to PACKAGE INFORMATION DATA BOOK.

ELECTRICAL CHARACTERISTICS

DC Characteristics

(V_{DD} = 2.4 to 3.3 V, Ta = -40 to +85°C)

Parameter	Symbol	Condition	Min.	Typ.	Max.	Unit
Power Supply Current	I _{DD1}	Operating mode No signal (V _{DD} = 3.0 V)	0	5.0	11.0	mA
	I _{DD2}	Operating mode No signal (V _{DD} = 3.0 V) SPO+, SPO- or EAR1, 2 is active	0	16.0	32.0	mA
	I _{DD3}	Power down mode (V _{DD} = 3.0 V, Ta = 25°C)	0	1.0	10	μA
Input Leakage Current	I _{IH}	V _I = V _{DD}	—	—	2.0	μA
	I _{IL}	V _I = 0 V	—	—	1.5	μA
Output High Voltage	V _{OH}	I _{OH} = 0.4 mA	0.5 × V _{DD}	—	V _{DD}	V
Output Low Voltage	V _{OL}	I _{OL} = -1.2 mA	0	0.2	0.4	V
Input Capacitance	C _{IN}	—	—	5	—	pF

Analog Interface Characteristics

(V_{DD} = 2.4 to 3.3 V, Ta = -40 to +85°C)

Parameter	Symbol	Condition	Min.	Typ.	Max.	Unit
Input Resistance	R _{INX}	MIC1I, MIC2I, MIC3-, MIC3+	10	—	—	MΩ
Output Load Resistance	R _{LGX1}	MIC1O, MIC2O, MIC3O, EXTO	20	—	—	kΩ
	R _{LGX2}	EAR1O, EAR2O	32	—	—	Ω
	R _{LGX3}	SPO+, SPO- differential output	8	—	—	Ω
Output Load Capacitance	C _{LGX}	Analog output	—	—	50	pF
Output Amplitude *	V _{O1}	MIC1O, MIC2O, MIC3O, EXTO, RL = 20 kΩ	—	—	1.3	V _{PP}
		EAR1O, EAR2O, RL = 32 Ω	—	—	1.3	V _{PP}
	V _{O2}	SPO+, SPO-, (Differential output) V _{DD} = 3.0 V, RL = 8 Ω	—	—	2.6	V _{PP}
V _{O3}	SPO- (Single output) V _{DD} = 3.0 V, RL = 20 kΩ, THD = 1%	2.0	2.6	—	V _{PP}	
Total Harmonic Distortion	THD	EAR1O, EAR2O, SPO+, SPO- V _{DD} = 3.0 V (at V _{O1} , V _{O2})	—	—	5.0	%
Offset Voltage	V _{OFGX1}	MIC1O, MIC2O, MIC3O	-40	—	40	mV
	V _{OFGX2}	EAR1O, EAR2O, SPO+, SPO-, EXTO	-100	—	100	mV
SG Output Voltage	V _{SG}	SG	—	1.4	—	V
SG Output Impedance	R _{SG}	SG	—	40	80	kΩ
Internal switch ON Impedance	R _{SW}	All internal analog switches (1.4 V DC bias)	—	—	300	Ω

* -7.7 dBm (600 Ω) = 0 dBm0, +3.17 dBm0 = 1.3 V_{PP}

AC Characteristics

(V_{DD} = 2.4 to 3.3 V, T_a = -40 to +85°C)

Parameter	Symbol	Condition			Min.	Typ.	Max.	Unit
		Frequency (Hz)	Level (dBm0)	Others				
Transmit Frequency Response	L _{oss} T1	0 to 60	0	—	25	—	—	dB
	L _{oss} T2	300 to 3000			-0.15	—	0.20	dB
	L _{oss} T3	1020			Reference			dB
	L _{oss} T4	3300			-0.15	—	0.80	dB
	L _{oss} T5	3400			0	—	0.80	dB
	L _{oss} R6	3968.75			13	—	—	dB
Receive Frequency Response *2	L _{oss} R1	0 to 3000	0	—	-0.15	—	0.20	dB
	L _{oss} R2	1020			Reference			dB
	L _{oss} R3	3300			-0.15	—	0.80	dB
	L _{oss} R4	3400			0	—	0.80	dB
	L _{oss} R5	3968.75			13	—	—	dB
Transmit Signal to Distortion Ratio	SD T1	1020	3	*1	35	—	—	dB
	SD T2		0		35	—	—	dB
	SD T3		-30		35	—	—	dB
	SD T4		-40		28	—	—	dB
	SD T5		-45		23	—	—	dB
Receive Signal to Distortion Ratio *2	SD R1	1020	3	*1	35	—	—	dB
	SD R2		0		35	—	—	dB
	SD R3		-30		35	—	—	dB
	SD R4		-40		28	—	—	dB
	SD R5		-45		23	—	—	dB
Transmit Gain Tracking	GT T1	1020	3	—	-0.5	—	0.5	dB
	GT T2		-10		Reference			dB
	GT T3		-40		-0.5	—	0.5	dB
	GT T4		-50		-1.0	—	1.0	dB
	GT T5		-55		-1.2	—	1.2	dB
Receive Gain Tracking *2	GT R1	1020	3	—	-0.5	—	0.5	dB
	GT R2		-10		Reference			dB
	GT R3		-40		-0.5	—	0.5	dB
	GT R4		-50		-1.0	—	1.0	dB
	GT R5		-55		-1.2	—	1.2	dB

*1 Use the P-message weighted filter.

*2 EXT0 output

AC Characteristics (Continued)

(V_{DD} = 2.4 to 3.3 V, T_a = -40 to +85°C)

Parameter	Symbol	Condition			Min.	Typ.	Max.	Unit
		Frequency (Hz)	Level (dBm0)	Others				
Idle Channel Noise	N _{IDLT}	—	MIC11, MIC21, MIC3 ± = SG	*1	—	—	-68	dBmOp
	N _{IDLR}	—	—	*1,*2,*4	—	—	-72	
Absolute Signal Amplitude	A _{VT}	1020	0	MIC10, MIC20, MIC30	0.285	0.320 *3	0.359	Vrms
	A _{VR}			EXTO	0.285	0.320 *3	0.359	Vrms
Power Supply Noise Rejection Ratio	P _{SRRT}	Noise frequency: 0 to 50 kHz	Noise level: 50 mVpp	—	30	—	—	dB
	P _{SRRR}				30	—	—	dB
Digital Input/Output Timing PCM Interface	t _{SDX}	—	1 LSTTL + 100 pF	See Figure 6	0	—	200	ns
	t _{SDR}				0	—	200	ns
	t _{XD1} t _{RD1}				0	—	200	ns
	t _{XD2} t _{RD2}				0	—	200	ns
I ² C Interface timing	f _{SCL}	—	CL = 50 pF	See Figure 7	0	—	100	kHz
	t _{BUF}				4.7	—	—	μs
	t _{HD:STA}				4.0	—	—	μs
	t _{LOW}				4.7	—	—	μs
	t _{HIGH}				4.0	—	—	μs
	t _{SU:STA}				4.7	—	—	μs
	t _{HD:DAT}				0	—	—	μs
	t _{SU:DAT}				250	—	—	ns
	t _{SU:STO}				4.0	—	—	μs

*1 Use the P-message weighted filter.

*2 PCMIN input code "11010101" (A-law)
"11111111" (μ-law)

*3 0.320 Vrms = 0 dBm0 = -7.7 dBm

*4 EXTO output

AC Characteristics (DTMF and Other Tones) $(V_{DD} = 2.4 \text{ to } 3.3 \text{ V}, T_a = -40 \text{ to } +85^\circ\text{C})$

Parameter	Symbol	Condition	Min.	Typ.	Max.	Unit	
Frequency Difference	D_{FT}	DTMF Tones, Other Tones	-1.5	—	+1.5	%	
Original (reference) Tones Signal Level *5	V_{TL}	Transmit tones (gain setting of 0 dB)	DTMF (Low) and Other Tones	-18	-16	-14	dBm0
	V_{TH}		DTMF (High)	-16	-14	-12	dBm0
	V_{RL}	Receive tones (gain setting of -6 dB)	DTMF (Low)	-4	-2	0	dBm0
	V_{RH}		DTMF (High) and Other Tones	-2	0	+2	dBm0
Relative Level of DTMF Tones	R_{DTMF}	$V_{TH}/V_{TL}, V_{RH}/V_{RL}$	+1	+2	+3	dB	

*5 Not including programmable gain set values

AC Characteristics (Programmable Gain Stages) $(V_{DD} = 2.4 \text{ to } 3.3 \text{ V}, T_a = -40 \text{ to } +85^\circ\text{C})$

Parameter	Symbol	Condition	Min.	Typ.	Max.	Unit
Gain Accuracy	D_G	All gain stages, to programmed value	-1	0	+1	dB

AC Characteristics (Voice Detect Function) $(V_{DD} = 2.4 \text{ to } 3.3 \text{ V}, T_a = -40 \text{ to } +85^\circ\text{C})$

Parameter	Symbol	Condition	Min.	Typ.	Max.	Unit
Voice Detection Time	T_{VON}	Silence → Voice	—	5	—	ms
	T_{VOF}	(Voice/silence differential: 10 dB)	140	160	180	ms
Voice Detection Accuracy	D_{VX}	For detection level set values by CR6-B6	-2.5	0	2.5	dB

AC Characteristics (General Purpose Drivers) $(V_{DD} = 2.4 \text{ to } 3.3 \text{ V}, T_a = -40 \text{ to } +85^\circ\text{C})$

Parameter	Symbol	Condition	Min.	Typ.	Max.	Unit
Output Voltage	V_O	$I_{OUT} = 150 \text{ mA}, \text{GP1} - \text{GP4}$	—	—	0.7	V
Output Load Resistance	R_O		20	—	—	Ω

AC Characteristics (Regulator 1 and 2) $(V_{DD} = 2.4 \text{ to } 3.3 \text{ V}, T_a = -40 \text{ to } +85^\circ\text{C})$

Parameter	Symbol	Condition	Min.	Typ.	Max.	Unit
Input Voltage	V_{i1}	$I_{OUT} = 50 \text{ mA}$	3.3	3.6	4.1	V
	V_{i2}	$I_{OUT} = 150 \text{ mA}$	3.5	3.6	4.1	V
Output Voltage	V_O	$R_{GIN} = 3.6 \text{ V},$ $I_{OUT} = 0 \text{ mA}, T_a = 25^\circ\text{C}$	2.93	3.00	3.07	V
Load Current	I_O	$3.5 \text{ V} < R_{GIN} < 4.1 \text{ V}$	—	—	150	mA
Dropout Voltage	V_{DROP}	$I_{OUT} = 150 \text{ mA}, R_{GIN} = 3.6 \text{ V}$	—	—	200	mV
Output Voltage Line Regulation	dV_O/dV_I	$I_{OUT} = 50 \text{ mA}$ $3.3 \text{ V} < R_{GIN} < 4.1 \text{ V}, T_a = 25^\circ\text{C}$	—	0.1	1.25	%/V
Standby Current	$I_{standby}$	$R_{G1PDN} = 0, R_{G2PDN} = 0$		0.1	10	μA

TIMING DIAGRAM

Transmit Side PCM Timing (Normal Synchronous Interface)

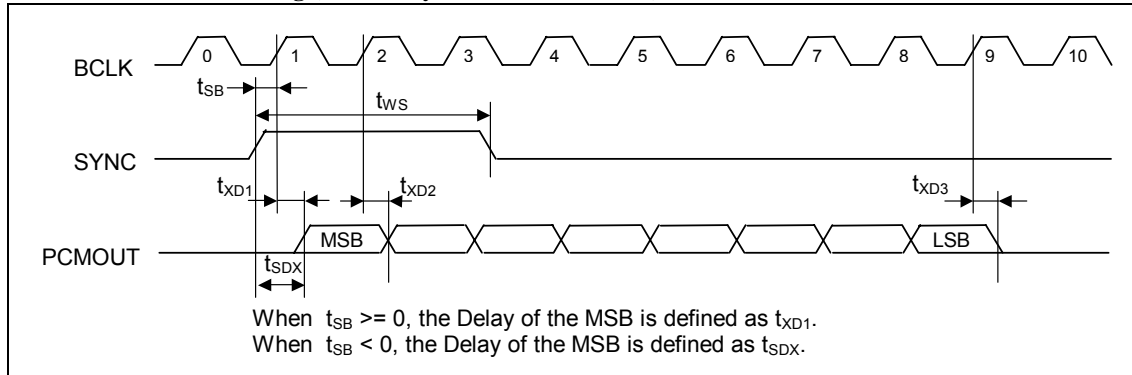

Transmit Side PCM Timing (Short Frame Synchronous Interface)

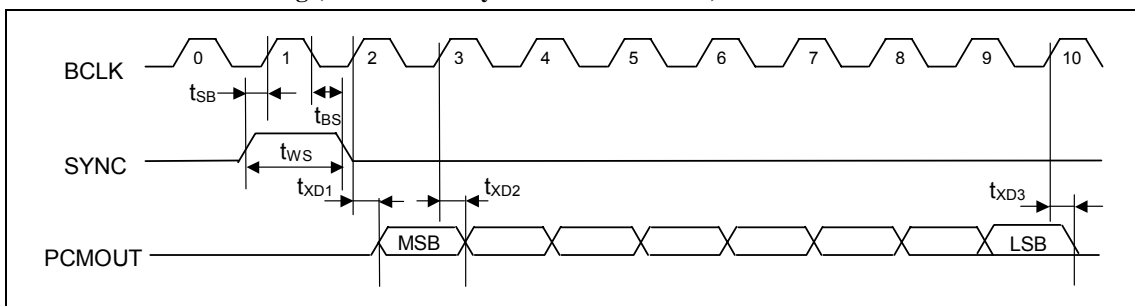

Receive Side PCM Timing (Normal Synchronous Interface)

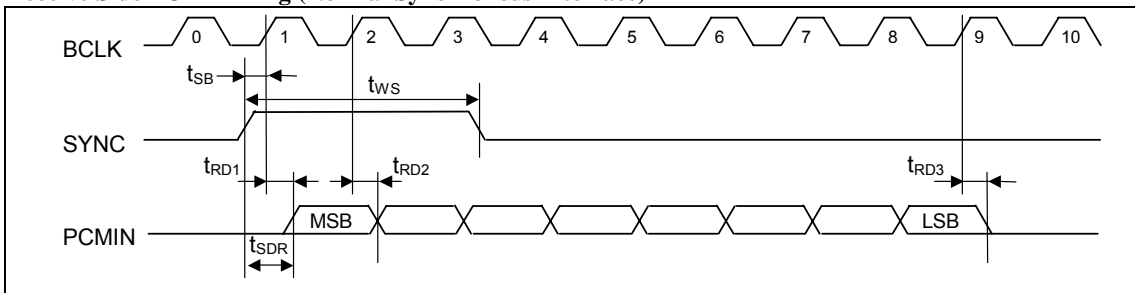

Receive Side PCM Timing (Short Frame Synchronous Interface)

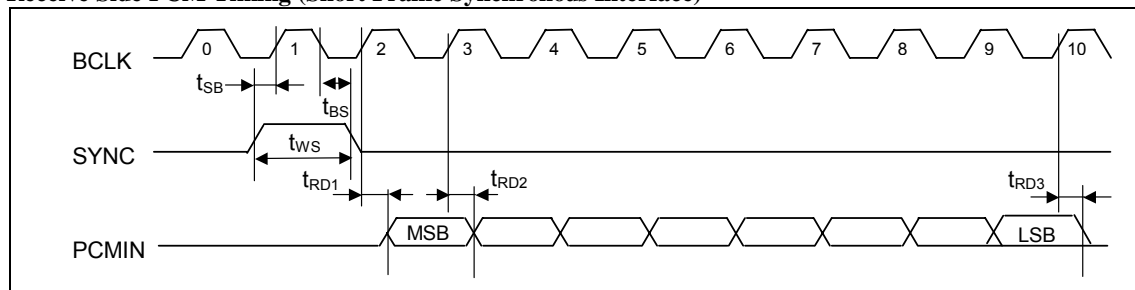
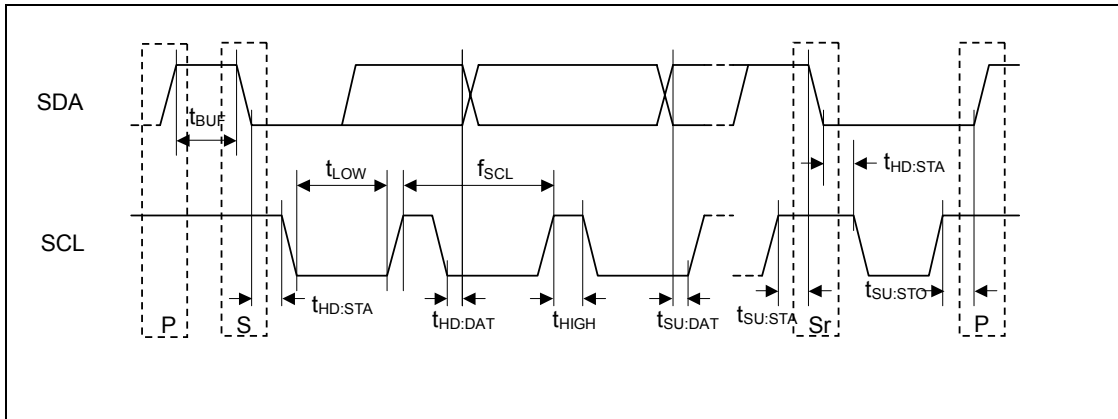

Figure 6 PCM Interface Timing

I²C Interface**Figure 7 I²C Interface Timing**

FUNCTIONAL DESCRIPTION

Control Registers

CR0 (Basic operating mode 1)

Note: The initial value means a value set when the device is reset by the $\overline{\text{PDN}}$ pin.

	B7	B6	B5	B4	B3	B2	B1	B0
CR0	A/ μ SEL	SPOUT PON	PDN ALL	PDN TX	PDN RX	SLP	SLP SEL	LNR
Initial value	0	0	0	0	0	0	0	0

B7..... PCM interface companding law select 0: μ -law 1: A-law

B6..... Power-on control for output amplifiers (SPO+, SPO-) 0: Power down 1: Power on

B5..... Power down (entire circuitry) 0: Power on 1: Power down
ORed with the inverted PDN signal. When using this data, set PDN to "L".
The control registers are not reset by this signal.

B4..... Power down (transmit only) 0: Power on 1: Power down

B3..... Power down (receive only) 0: Power on 1: Power down

B2..... Slope filter enable 0: Slope filter disable 1: Slope filter enable

B1..... Slope filter frequency response select 0: CASE1 1: CASE2

Either CASE1 or CASE2 can be selected in Figure 8.

B0..... PCM interface linear code select

0: PCM companding law selected by CR0-B7

1: 14-bit linear code (2's complement)

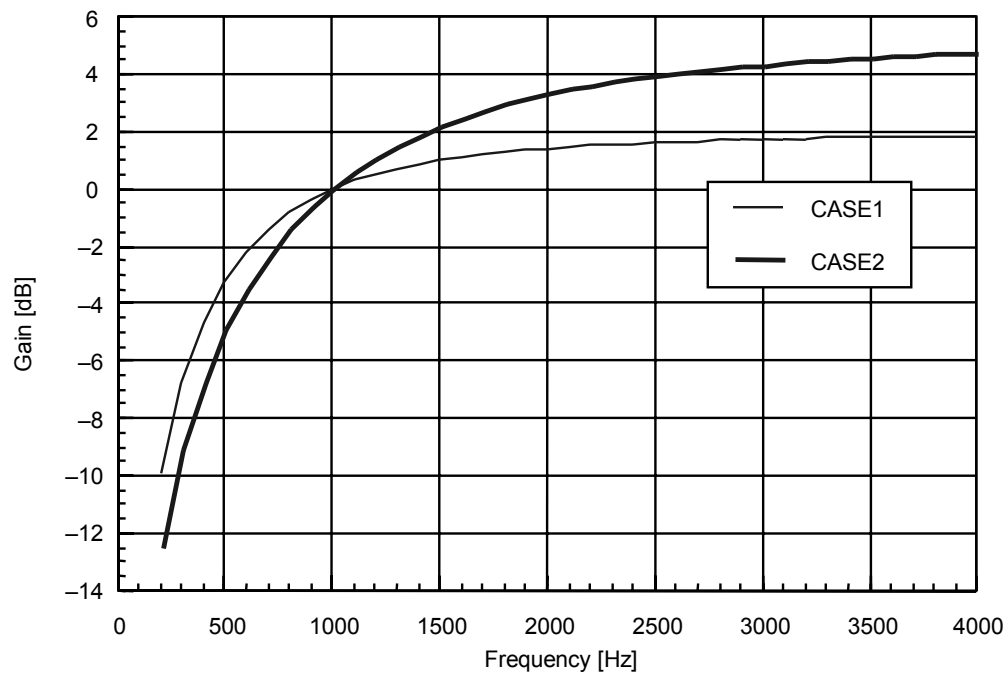

Figure 8 Slope Filter Frequency Characteristics

CR1 (Basic operating mode 2)

	B7	B6	B5	B4	B3	B2	B1	B0
CR1	MIC SEL1	MIC SEL0	SP SEL1	SP SEL0	SHORT FRAME	—	SW C/A	RX PAD
Initial Value	0	0	0	0	0	0	0	0

B7, B6..... Selection of an input amplifier to encoder

- (B7, B6) = (0, 0): MIC1
- = (0, 1): MIC2
- = (1, 0): MIC3
- = (1, 1): No input

Amplifiers which are not selected are powered down and their outputs go in the high impedance state.

B5, B4..... Selection of an output amplifier

- (B5, B4) = (0, 0): EXT0
- = (0, 1): EAR10
- = (1, 0): EAR20
- = (1, 1): No output

Amplifiers which are not selected are powered down and their outputs go in the high impedance state.

B3 Short frame synchronous interface select

- 0: Long frame synchronous interface,
- 1: Short frame synchronous interface

B2 Not used. When writing data, write "0".

B1 Analog switch control

- 0: The SWB pin is internally connected to the SWA pin.
 - 1: The SWB pin is internally connected to the SWC pin.
- The unconnected pins go in a high impedance state.

B0 Receive side PAD

- 0: No pad
- 1: A pad of 12 dB loss is inserted in the receive side voice path.

CR2 (PCM CODEC operating mode setting and transmit/receive gain adjustment)

	B7	B6	B5	B4	B3	B2	B1	B0
CR2	TX ON/OFF	TX GAIN2	TX GAIN1	TX GAIN0	RX ON/OFF	RX GAIN2	RX GAIN1	RX GAIN0
Initial Value	0	0	1	1	0	0	1	1

B7 Transmit side PCM signal ON/OFF 0: ON 1: OFF

B6, B5, B4..... Transmit side signal gain adjustment (refer to Table 2)

B3 Receive side PCM signal ON/OFF 0: ON 1: OFF

B2, B1, B0..... Receive side signal gain adjustment (refer to Table 2)

Table 2 Transmit/Receive Gain Settings

B6	B5	B4	Transmit Gain	B2	B1	B0	Receive Gain
0	0	0	-6 dB	0	0	0	-12 dB
0	0	1	-4 dB	0	0	1	-9 dB
0	1	0	-2 dB	0	1	0	-6 dB
0	1	1	0 dB	0	1	1	-3 dB
1	0	0	+2 dB	1	0	0	0 dB
1	0	1	+4 dB	1	0	1	+3 dB
1	1	0	+6 dB	1	1	0	+6 dB
1	1	1	+8 dB	1	1	1	+9 dB

The above gain settings table shows the transmit/receive voice signal gain settings and the transmit side gain settings for DTMF tones and other tones. The DTMF and other tone transmit signals are enabled by CR4-B6, and the gain setting is referenced to the levels shown below.

DTMF tones (low group):..... -16 dBm0

DTMF tones (high group) and other tones: ... -14 dBm0

For example, if the transmit gain set value is set to +8 dB (B6, B5, B4) = (1,1,1), then the following tones are output at the PCMOOUT pin.

DTMF tones (low group):..... -8 dBm0

DTMF tones (high group) and other tones: ... -6 dBm0

Gains of the side tone (path to receive side from transmit side) and the receive side tone can be set by register CR3.

CR3 (Side tone and other tone generator gain setting)

	B7	B6	B5	B4	B3	B2	B1	B0
CR3	SIDE TONE GAIN2	SIDE TONE GAIN1	SIDE TONE GAIN0	TONE ON/OFF	TONE GAIN3	TONE GAIN2	TONE GAIN1	TONE GAIN0
Initial Value	0	0	0	0	0	0	0	0

B7, B6, B5 Side tone path gain setting (refer to Table 3)

B4..... Tone generator ON/OFF 0: OFF 1: ON

B3, B2, B1, B0... Tone generator gain adjustment for receive side (refer to Table 4)

Table 3 Side Tone Gain Settings

B7	B6	B5	Side Tone Path Gain
0	0	0	OFF
0	0	1	-15 dB
0	1	0	-13 dB
0	1	1	-11 dB
1	0	0	-9 dB
1	0	1	-7 dB
1	1	0	-5 dB
1	1	1	-3 dB

Table 4 Receive Side Tone Generator Gain Settings

B3	B2	B1	B0	Tone Generator Gain	B3	B2	B1	B0	Tone Generator Gain
0	0	0	0	OFF	1	0	0	0	-20 dB
0	0	0	1	-34 dB	1	0	0	1	-18 dB
0	0	1	0	-32 dB	1	0	1	0	-16 dB
0	0	1	1	-30 dB	1	0	1	1	-14 dB
0	1	0	0	-28 dB	1	1	0	0	-12 dB
0	1	0	1	-26 dB	1	1	0	1	-10 dB
0	1	1	0	-24 dB	1	1	1	0	-8 dB
0	1	1	1	-22 dB	1	1	1	1	-6 dB

The receive side tone generator gain settings shown in Table 4 are referenced to the following levels as a reference.

DTMF tones (low group):.....+4 dBm0

DTMF tones (high group) and others tones: .+6 dBm0

For example, if the tone generator gain set value is set to -6 dB (B3, B2, B1, B0) = (1, 1, 1, 1), then tones at the following levels are output at EXT0.

DTMF tone (low group):-2 dBm0

DTMF tone (high group) and other tones:..... 0 dBm0

CR4 (Tone generator operating mode and frequency select)

	B7	B6	B5	B4	B3	B2	B1	B0
CR4	DTMF/ Others SEL	TONE SEND	—	TONE4	TONE3	TONE2	TONE1	TONE0
Initial Value	0	0	0	0	0	0	0	0

B7.....DTMF or other tones select 0: Others 1: DTMF
 B6.....Tone transmit enable (Transmit side) 0: Voice signal transmit 1: Tone transmit
 B5.....Not used. When writing data, write "0".
 B4, B3, B2, B1, B0..Tone frequency setting (refer to Tables 5-1 and 5-2)

(a) B7 = 1 (DTMF tone)

Table 5-1 Tone Generator Frequency Settings

B4	B3	B2	B1	B0	Frequency	B4	B3	B2	B1	B0	Frequency
*	0	0	0	0	697 Hz + 1209 Hz	*	1	0	0	0	852 Hz + 1209 Hz
*	0	0	0	1	697 Hz + 1336 Hz	*	1	0	0	1	852 Hz + 1336 Hz
*	0	0	1	0	697 Hz + 1477 Hz	*	1	0	1	0	852 Hz + 1477 Hz
*	0	0	1	1	697 Hz + 1633 Hz	*	1	0	1	1	852 Hz + 1633 Hz
*	0	1	0	0	770 Hz + 1209 Hz	*	1	0	0	0	941 Hz + 1209 Hz
*	0	1	0	1	770 Hz + 1336 Hz	*	1	1	0	1	941 Hz + 1336 Hz
*	0	1	1	0	770 Hz + 1477 Hz	*	1	1	1	0	941 Hz + 1477 Hz
*	0	1	1	1	770 Hz + 1633 Hz	*	1	1	1	1	941 Hz + 1633 Hz

*Undefined

(b) B7 = 0 (Other tones)

Table 5-2 Tone Generator Frequency Settings

B4	B3	B2	B1	B0	Frequency	B4	B3	B2	B1	B0	Frequency
0	0	0	0	0	2730 Hz/2500 Hz 8 Hz wamb.	1	0	0	0	0	1200 Hz
0	0	0	0	1	2000 Hz/2667 Hz 8 Hz wamb.	1	0	0	0	1	1300 Hz
0	0	0	1	0	1000 Hz/1333 Hz 8 Hz wamb.	1	0	0	1	0	
0	0	0	1	1		1	0	0	1	1	1477 Hz
0	0	1	0	0		1	0	1	0	0	1633 Hz
0	0	1	0	1		1	0	1	0	1	2000 Hz
0	0	1	1	0		1	0	1	1	0	2100 Hz
0	0	1	1	1		1	0	1	1	1	
0	1	0	0	0		1	1	0	0	0	2400 Hz
0	1	0	0	1	400 Hz	1	1	0	0	1	
0	1	0	1	0	440 Hz	1	1	0	1	0	2500 Hz
0	1	0	1	1	480 Hz	1	1	0	1	1	
0	1	1	0	0		1	1	1	0	0	
0	1	1	0	1	667 Hz	1	1	1	0	1	2700 Hz
0	1	1	1	0	800 Hz	1	1	1	1	0	
0	1	1	1	1	1000 Hz	1	1	1	1	1	3000 Hz

CR5 (Regulator control, General purpose driver control)

	B7	B6	B5	B4	B3	B2	B1	B0
CR5	GP1 SEL CR/TONE	—	RG2PDN	RG1PDN	GP4C	GP3C	GP2C	GP1C
Initial Value	0	0	0	0	0	0	0	0

- B7..... Selection of how to control General purpose driver 1.
0: Control register CR5-B0 1: GP1 is controlled by a sign bit of the receiver.
- B6..... Not used
- B5..... Power down control for Regulator 2
0: Power down 1: Power on
When using this data, set the RG2PDN pin at a "L" level.
- B4..... Power down control for Regulator 1
0: Power down 1: Power on
When using this data, set the RG1PDN pin at a "L" level.
- B3, B2, B1, B0... General purpose driver control
0: Off (high impedance) 1: On ("L" output)

CR6 (VOX function control)

	B7	B6	B5	B4	B3	B2	B1	B0
CR6	VOX ON/OFF	ON LVL1	—	—	—	—	—	—
Initial Value	0	0	*	0	0	0	0	0

- B7..... Voice/silence detect function ON/ OFF 0: OFF 1: ON
If B7 is set to a logic "1", B3 should be set to a logic "1".
- B6..... Voice detector level setting
0: -26 dBm0 1: -38 dBm0
- B5..... Reserved bit. When writing data, write "0".
- B4, B3, B2, B1, B0..... Not used. When writing data, write "0".

CR7 (Detect register, read only)

	B7	B6	B5	B4	B3	B2	B1	B0
CR7	VOX OUT	TX Noise Level1	TX Noise Level0	—	—	—	—	—
Initial Value	0	0	0	*	*	*	*	*

*Used for testing the device and undefined

- B7..... Transmit side voice/silence detection 0: silence 1: voice detect
- B6, B5..... Transmit side silence detect level (indicator)
(0,0): Below -50 dBm0 (0,1): -40 to -50 dBm0
(1,0): -30 to -40 dBm0 (1,1): Above -30 dBm0
Note: These outputs are enabled only when the VOX (CR6-B7) = "1".
- B4, B3, B2, B1, B0.... Not used

APPLICATION CIRCUIT

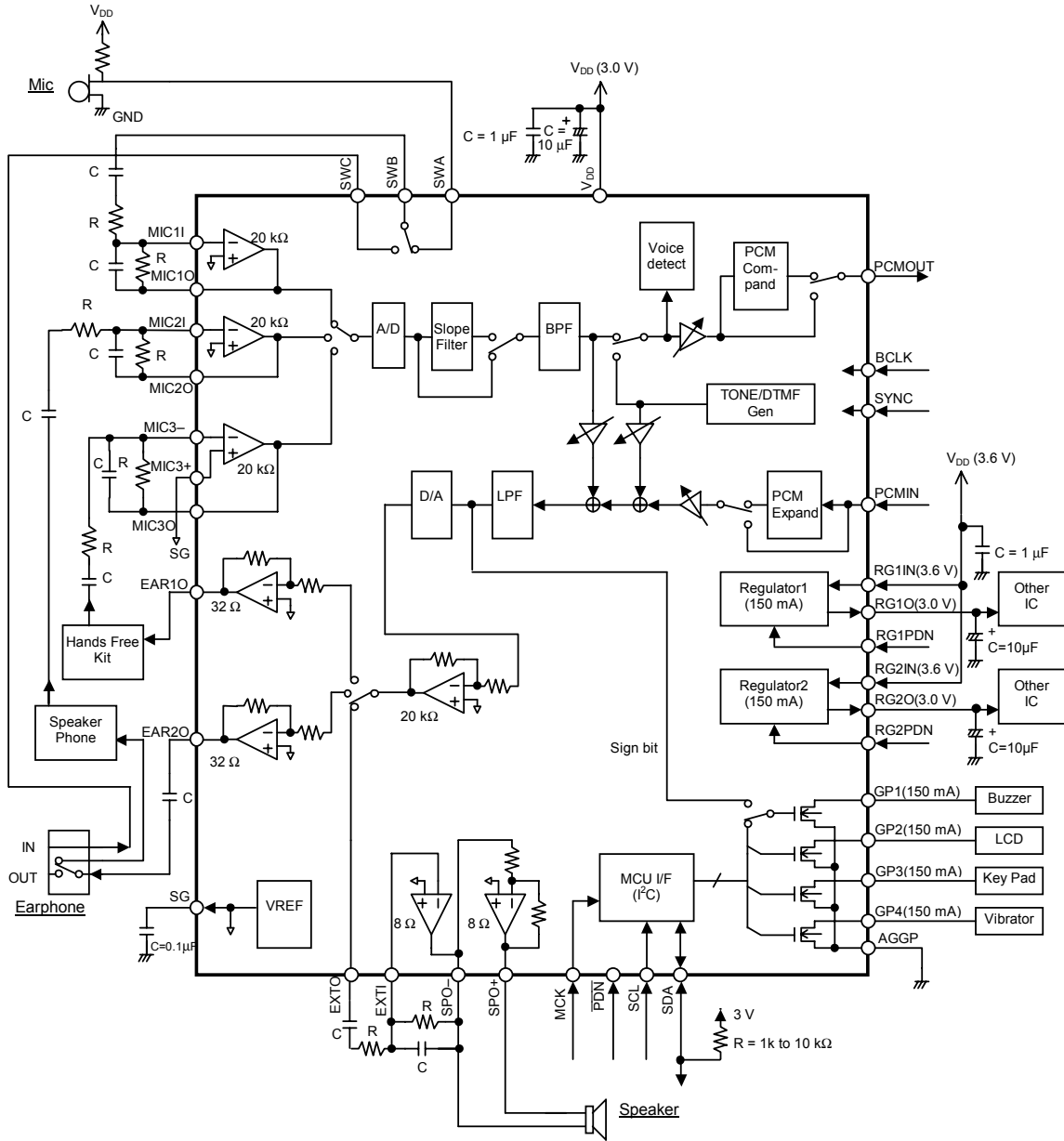

PACKAGE DIMENSIONS

(Unit: mm)

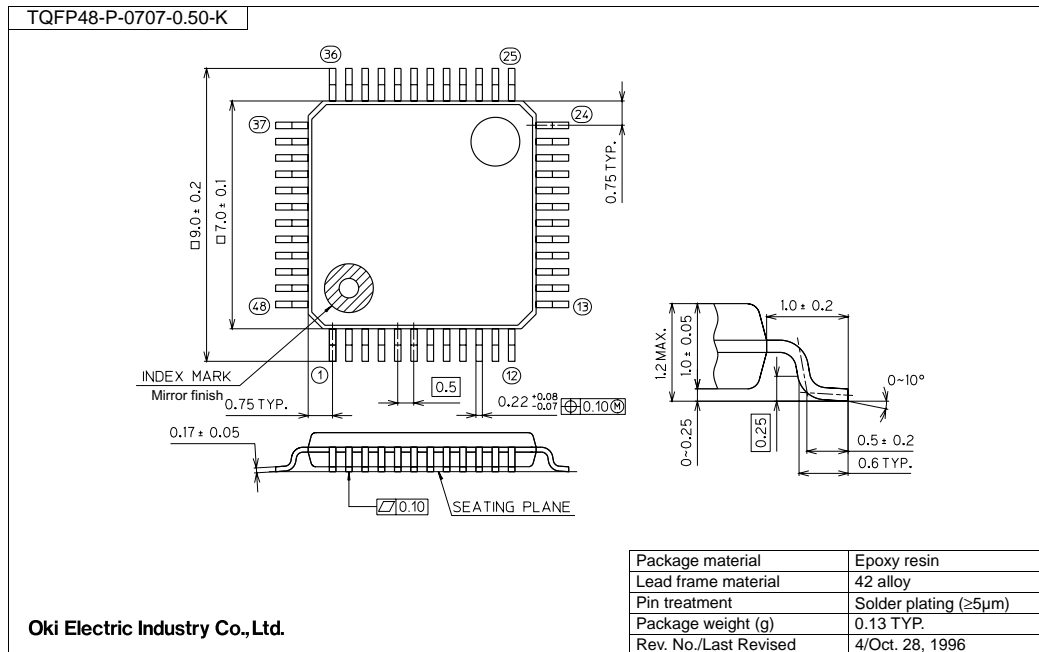

Notes for Mounting the Surface Mount Type Package

The surface mount type packages are very susceptible to heat in reflow mounting and humidity absorbed in storage.

Therefore, before you perform reflow mounting, contact Oki's responsible sales person for the product name, package name, pin number, package code and desired mounting conditions (reflow method, temperature and times).

REVISION HISTORY

Document No.	Date	Page		Description
		Previous Edition	Current Edition	
FEDL7041-01	Nov. 2000	—	—	1 st Edition
FEDL7041-02	Jun. 16, 2004	8	8	More clarification of PCMOUT output state
FEDL7041-03	Nov. 2, 2005	11	11	Addition of t_{SB}
		17	17	Addition of t_{SB} Addition of description about t_{XD1} and t_{SDX}
FEDL7041-04	Mar. 2, 2006	24	24	Addition of description about CR6-B3

NOTICE

1. The information contained herein can change without notice owing to product and/or technical improvements. Before using the product, please make sure that the information being referred to is up-to-date.
2. The outline of action and examples for application circuits described herein have been chosen as an explanation for the standard action and performance of the product. When planning to use the product, please ensure that the external conditions are reflected in the actual circuit, assembly, and program designs.
3. When designing your product, please use our product below the specified maximum ratings and within the specified operating ranges including, but not limited to, operating voltage, power dissipation, and operating temperature.
4. Oki assumes no responsibility or liability whatsoever for any failure or unusual or unexpected operation resulting from misuse, neglect, improper installation, repair, alteration or accident, improper handling, or unusual physical or electrical stress including, but not limited to, exposure to parameters beyond the specified maximum ratings or operation outside the specified operating range.
5. Neither indemnity against nor license of a third party's industrial and intellectual property right, etc. is granted by us in connection with the use of the product and/or the information and drawings contained herein. No responsibility is assumed by us for any infringement of a third party's right which may result from the use thereof.
6. The products listed in this document are intended for use in general electronics equipment for commercial applications (e.g., office automation, communication equipment, measurement equipment, consumer electronics, etc.). These products are not, unless specifically authorized by Oki, authorized for use in any system or application that requires special or enhanced quality and reliability characteristics nor in any system or application where the failure of such system or application may result in the loss or damage of property, or death or injury to humans.
Such applications include, but are not limited to, traffic and automotive equipment, safety devices, aerospace equipment, nuclear power control, medical equipment, and life-support systems.
7. Certain products in this document may need government approval before they can be exported to particular countries. The purchaser assumes the responsibility of determining the legality of export of these products and will take appropriate and necessary steps at their own expense for these.
8. No part of the contents contained herein may be reprinted or reproduced without our prior permission.

Copyright 2006 Oki Electric Industry Co., Ltd.