MSM7731-02

Dual Echo Canceler & Noise Canceler with Dual Codec for Hands-Free

GENERAL DESCRIPTION

The MSM7731 is an IC device developed for portable, handsfree communication with built-in line echo canceler, acoustic echo canceler, and transmission signal noise canceler. Built-in to the voice signal interface is a linear CODEC for the analog interface on the acoustic-side, and a linear CODEC for the analog interface on the line-side. On the line-side, in addition to the analog interface, there is also a μ -law PCM/16-bit linear digital interface. Equipped with gain and mute controls for data transmission and reception, a μ -law PCM/16-bit linear digital interface for memo recording and message output, and transfer clock and sync clock generators for digital communication, this device is ideally suited for a handsfree system.

FEATURES

- Single 3 V Power Supply Operation (2.7 to 3.6 V)
- Built-in 2-channel (line and acoustic) echo canceler
 - Echo attenuation : 35 dB (typ.) for white noise
 - Cancelable echo delay time :
 - Line echo canceler + acoustic echo canceler : Tlined = 27 ms (max.)
Tacoud = 59 ms – Tlined (max.)
 - Acoustic echo canceler only : Tacoud = 59 ms (max.)
- Built-in transmission signal noise canceler
 - Noise attenuation : 17 dB (typ.) for white noise
40 dB (typ.) for single tone
- Built-in 2-channel CODEC
 - Synchronous transmission and reception enables full duplex operation
- Built-in analog input gain amp stage (max. gain = 30 dB)
- Analog output configuration: Push-pull drive (can drive a 1.2 k Ω load)
- Built-in transmit slope filter
- Digital interface coding formats : μ -law PCM, 16-bit linear (2's complement)
- Digital interface sync formats : Normal-sync, short-frame-sync
- Built-in digital transmission clock generators
 - Sync clock (SYNC) : 8 kHz output
 - Transmission clock (BCLK) : 64 kHz output (μ -law PCM)/128 kHz output (16-bit linear)
- Digital transmission rate
 - External input : 64 to 2048 kbps
 - Internal generation : 64 kbps (μ -law PCM)/128 kbps (16-bit linear)
- Fixed digital interface sync clock (SYNC) enables automatic power-down
- Master clock frequency : 19.2 MHz
 - Compatible with crystal oscillator and crystal
- Low power consumption
 - Operating mode : typ. 35 mA (when $V_{DD} = 3.0$ V in a silent mode)
 - Power down operation : typ. 0.02 mA (when $V_{DD} = 3.0$ V in a silent mode)
- Control by both the serial microcomputer interface and parallel port is possible
- Transmit/receive mute function, transmit/receive programmable gain setting
- Package : 64-pin plastic QFP (QFP64-P-1414-0.80-BK)(MSM7731-02GA)

BLOCK DIAGRAM

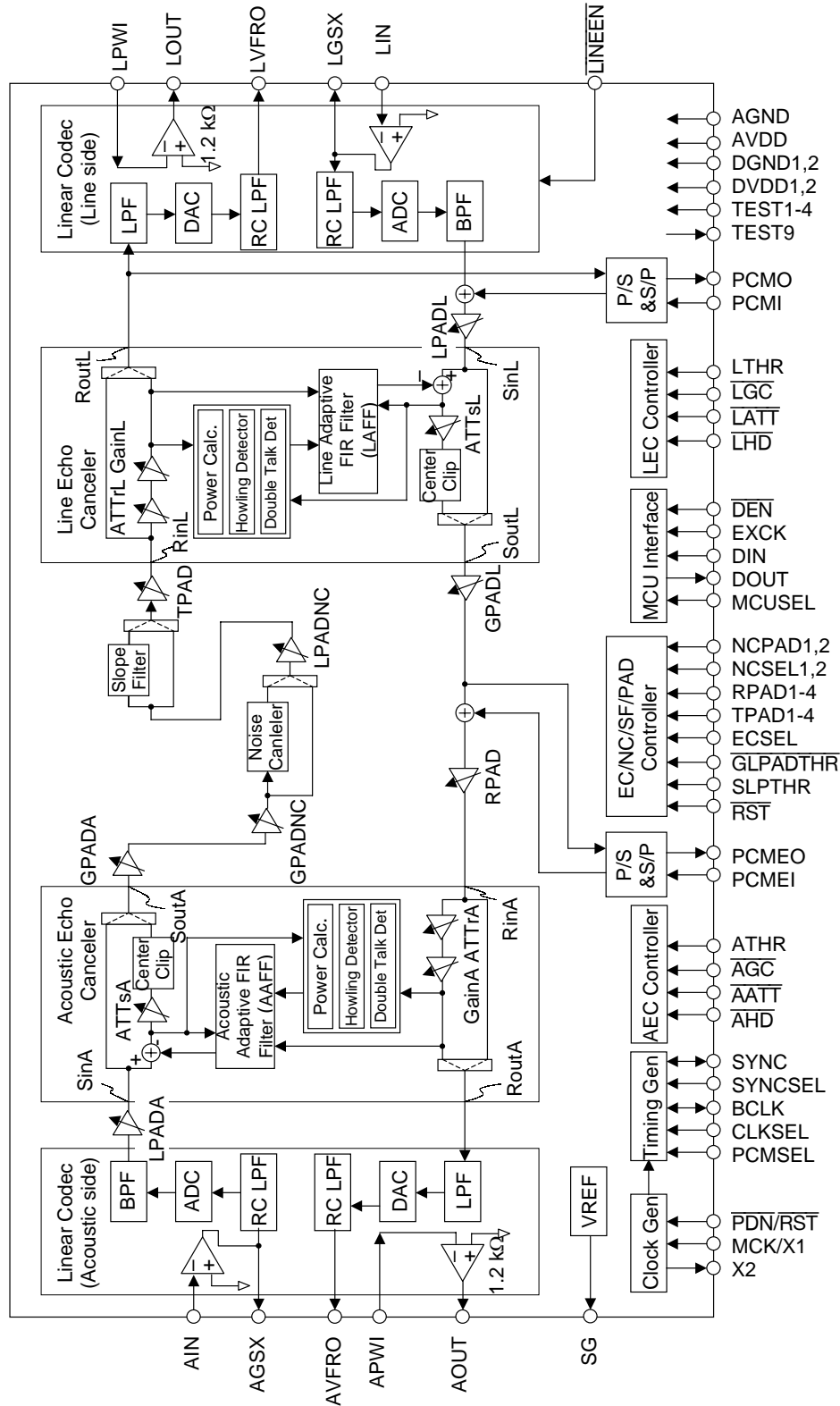

PIN CONFIGURATION (TOP VIEW)

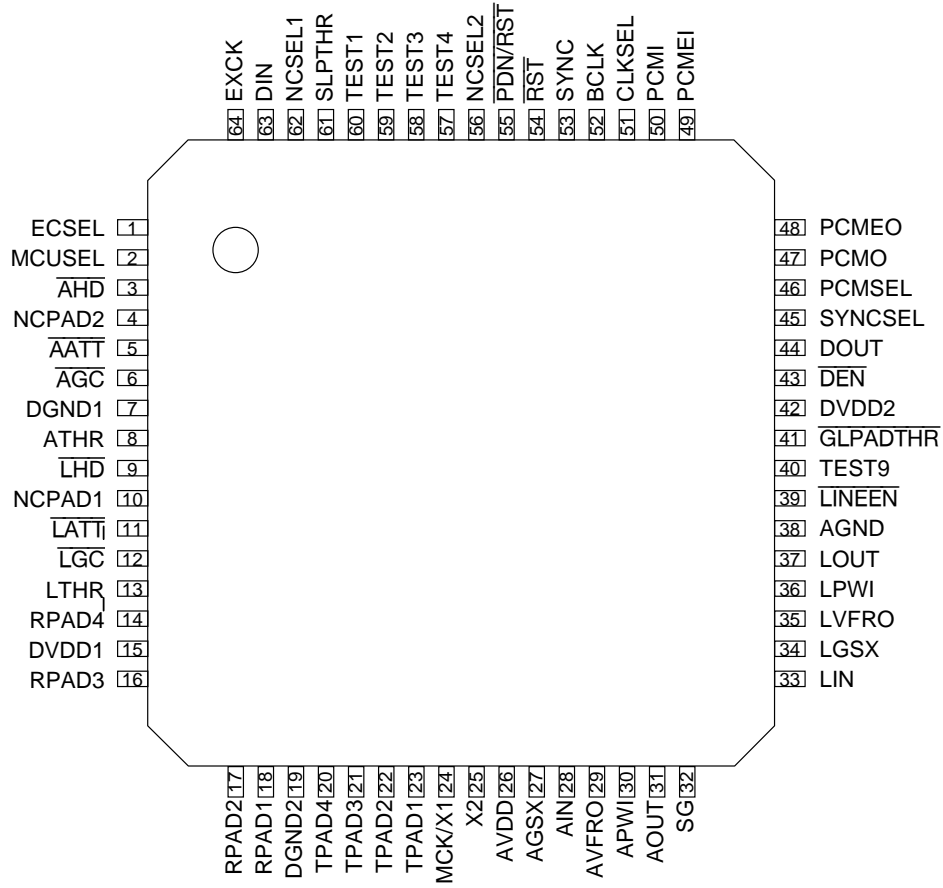

64-Pin Plastic QFP

PIN FUNCTIONAL DESCRIPTION

AIN, AGSX

These are the acoustic analog input and level adjusting pins. The AIN pin is connected to the inverting input of the internal amp and the AGSX pin is connected to the amp output. For level adjustment, refer to the diagram below (Figure 1). At power-down reset, the AGSX pin goes to a high impedance state.

AVFRO, AOUT, APWI

These are acoustic analog output and level adjusting pins. The AVFRO pin is an audio output and can directly drive 20 kΩ. The AOUT pin is an analog output and can directly drive a load of 1.2 kΩ. For level adjustment, refer to the diagram below (Figure 1). At power-down reset, these output pins go to a high impedance state.

LIN, LGSX

These are the line analog input and level adjusting pins. The LIN pin is connected to the inverting input of the internal amp and the LGSX pin is connected to the amp output. For level adjustment, refer to the diagram below (Figure 1). At power-down reset, the LGSX pin goes to a high impedance state. If LIN is not used, short the LIN and LGSX together.

LVFRO, LOUT, LPWI

These are acoustic analog output and level adjusting pins. The LVFRO pin is an audio output and can directly drive 20 kΩ. The LOUT pin is an analog output and can directly drive a load of 1.2 kΩ. For level adjustment, refer to the diagram below (Figure 1). At power-down reset, these output pins go to a high impedance state. If LOUT is not used, short the LPWI and LOUT pins together.

LINEEN

This is the power-down control pin for the line CODEC. A logic “0” continues normal operation and a logic “1” power down only the line CODEC. If the line CODEC is not used, power down the line CODEC and short the LIN pin to the LGSX pin and the LPWI pin to the LOUT pin. This procedure results in the low consumption of electrical power. At power-down, the output pins go to a high impedance state. If the pin setting is changed, reset must be activated by either the $\overline{\text{PDN/RST}}$ pin or the PDN/RST bit (CR0-B7). This pin is ORed with CR0-B5 of the control register. Refer to the section “RELATIONSHIP BETWEEN PINS AND CONTROL REGISTERS”.

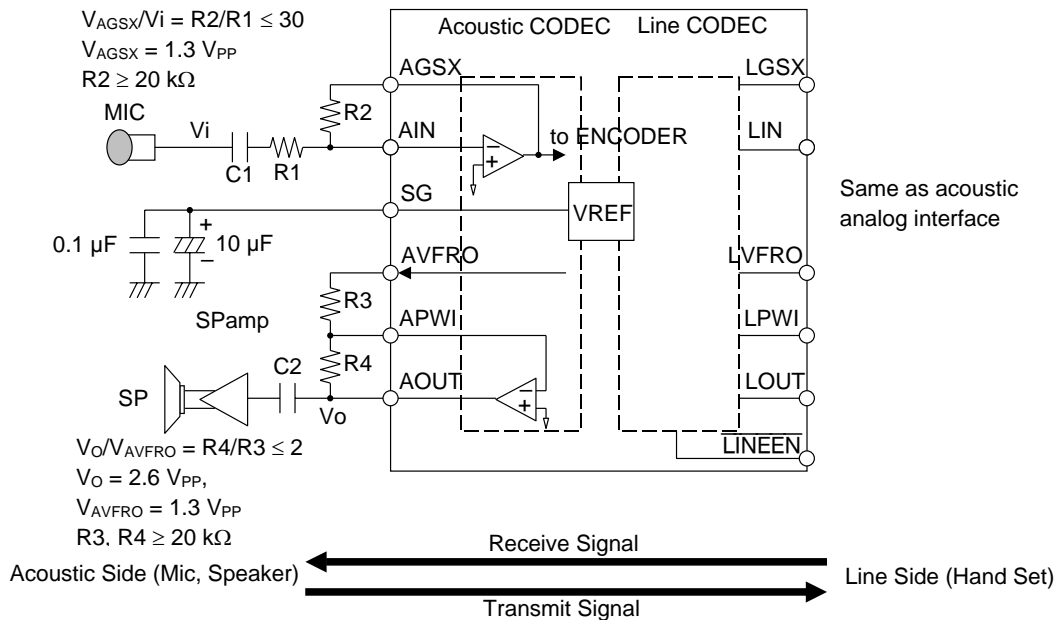

Figure 1 Analog Interface

AGND

This is analog ground pin.

DGND1, DGND2

These are the digital ground pins.

AV_{DD}

This is the analog +3 V power supply pin.

DV_{DD1}, DV_{DD2}

These are the digital +3 V power supply pins.

SG

This is the output pin for the analog signal ground potential. The output voltage is approximately 1.4 V. Insert 10 μ F and 0.1 μ F ceramic bypass capacitors between the AGND and SG pin. At power-down rest, this output becomes 0 V.

 $\overline{\text{PDN/RST}}$

This is the power-down reset control input pin. If a logic “0” is input to this pin, the device enters the power-down state. At this time, all control register bits, internal variables, and coefficients of echo cancelers and noise cancelers will be reset. After the power-down reset state is released, the device enters the initial mode (refer to the CR0 control register description). During normal operation, set this pin to a logic “1”. The $\overline{\text{PDN/RST}}$ pin is ORed (negative logic) with CR0-B7 of the control register. Refer to the section “RELATIONSHIP BETWEEN PINS AND CONTROL REGISTERS”.

MCK/X1

This is the master clock input pin. The clock frequency is 19.2 MHz. The input clock may be asynchronous with respect to the SYNC signal or the BCLK signal. Refer to Figure 2 (a) for an example application of an external clock and Figure 2 (b) for an example oscillator circuit.

X2

This is the crystal oscillator output pin. If an existing external clock is to be used, leave this pin open and input the clock to the MCK pin. Refer to Figure 2 (b) for an example oscillator circuit.

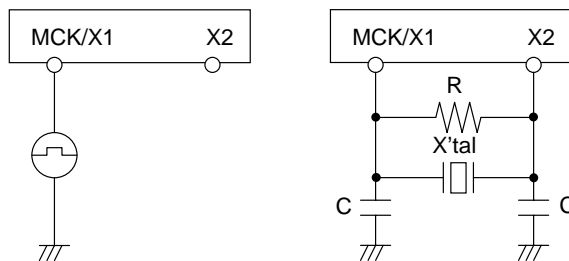

X'tal (19.2 MHz)	C	R
HC-49/U	10 pF	1 M Ω

Figure 2 (a) External Clock Application Example

Figure 2 (b) Oscillator Circuit Example

SYNC

This is the 8 kHz sync signal I/O pin for digital data communication. This pin is switched to function as an input or output by the CLKSEL pin. If the internal clock mode is selected by the CLKSEL pin, an 8 kHz clock synchronized to be BCLK signal is output and digital data communication is performed. If the external clock mode is selected by the CLKSEL pin, this pin becomes an input that requires an 8 kHz clock input synchronized to be BCLK pin, and digital data communication is performed based on this input clock. This pin enables automatic power-down control. Fixing this pin to a logic "1" or logic "0" causes this device to enter the power-down state. Two kinds of power-down modes can be selected by the SYPDN (CR11-B0) bit of the control register. For the power-down mode, refer to the description of control register CR11.

BCLK

This is the shift clock I/O pin for digital data communication. This pin is switched to function as an input or output by the CLKSEL pin.

If the internal clock mode is selected by the CLKSEL pin, a 64 kHz or 128 kHz clock synchronized to the SYNC signal is output and digital data communication is performed. Regardless of the PCMSEL (CR11-B1) setting, when this pin is set to a logic "1", the BCLK-pin outputs 64kHz clocks; when this pin is set to a logic "0", the BCLK-pin outputs 128kHz clocks.

If the external clock mode is selected by the CLKSEL pin, this pin becomes an input that requires a clock input synchronized to the SYNC. In this case, the clock frequency range is from 64 kHz to 2048 kHz.

CLKSEL

This pin selects internal or external clock modes for the SYNC and BCLK signals. A logic "0" selects the internal clock mode. At this time, SYNC and BCLK pins are configured as output pins and each internally generated clock is output to perform digital data communication. A logic "1" selects the external clock mode and configures the SYNC and BCLK pins as input pins. At this time, digital data communication is performed with the externally input SYNC and BCLK clocks. If digital data communication is not used, set this pin to a logic "0" to select internal clocks. If the pin setting is changed, reset must be activated by either the $\overline{\text{PDN/RST}}$ pin or the PDN/RST bit (CR0-B7).

PCMI

This is the digital receive signal input pin on the line-side. This input signal is shifted at the rising edge of the BCLK signal and input. The beginning of digital data is identified on the rising edge of the SYNC signal. The coding format can be selected as μ -law PCM or 16-bit linear (2's complement) by the PCMSEL pin or PCMSEL (CR11-B1) bit. If the PCMI pin is not used, set it to a logic "1" if μ -law PCM has been selected, or a logic "0" if 16-bit linear mode has been selected. The sync format can be selected as normal-sync or short-frame-sync by the SYNCSEL pin. Refer to Figure 3 for the timing. This digital input signal is added internally to the CODEC digital output signal. Be careful of overflow when using the CODEC.

PCMO

This is the digital transmit signal output pin on the line-side. This output signal is synchronized to the rising edge of the BCLK and SYNC signals and then output. When not used for output, this pin is in the high impedance state. It is at high impedance during the power-down reset and the initial modes. The coding format can be selected as μ -law PCM or 16-bit linear (2's complement) by the PCMSEL pin or PCMSEL (CR11-B1) bit. The sync format can be selected as normal-sync or short-frame-sync by the SYNCSEL pin. Refer to Figure 3 for the timing.

PCMEI

This is the message signal input pin. Use this pin when a message is output to the speaker on the acoustic-side. This input signal is shifted at the rising edge of the BCLK signal and then input. The beginning of digital data is identified on the rising edge of the SYNC signal. The coding format can be selected as μ -law PCM or 16-bit linear (2's complement) by the PCMSEL pin or PCMSEL (CR11-B1) bit. If the PCMEI pin is not used, set it to a logic "1" if μ -law PCM has been selected, or a logic "0" if 16-bit linear mode has been selected. The sync format can be selected as normal-sync or short-frame sync by the SYNCSEL pin. Timing is the same as for the PCMI pin (refer to Figure 3). This digital input signal is added internally to the echo canceler output signal. Be careful of overflow during telephone conversations.

PCMEO

This output pin is for memo recording. Use it with the memo function. This output signal is synchronized to the rising edge of the BCLK and SYNC signals and then output. When not used for output, this pin is in the high impedance state. It is also at high impedance during the power-down reset and the initial modes. The coding format can be selected as μ -law PCM or 16-bit linear (2's complement) by the PCMSEL pin or PCMSEL (CR11-B1) bit. The sync format can be selected as normal-sync or short-frame-sync by the SYNCSEL pin. Timing is the same as for the PCMO pin (refer to Figure 3).

SYNCSEL

This is the sync timing selection pin for digital data communication. A logic "0" selects normal-sync timing and a logic "1" selects short-frame-sync timing. Refer Figure 3 for the timing. If the pin setting is changed, reset must be activated by either the $\overline{\text{PDN/RST}}$ pin or the PDN/RST bit (CR0-B7)

PCMSEL

This is the coding format selection pin for digital data communication. A logic "1" selects μ -law PCM and a logic "0" selects 16-bit linear (2's complement) coding format. When an internal clock is selected, the BCLK signal determines the output clock frequency. If the digital interface is not used, set this pin to logic "0" to select 16-bit linear coding format.

If the pin setting is changed, reset must be performed by either the $\overline{\text{PDN/RST}}$ pin or the PDN/RST bit (CR0-B7). This pin is logically ORed with the PCMSEL bit (CR11-B1) although the BCLK output frequency in an internal clock mode is solely as per this pin regardless of the PCMSEL bit (CR11-B1). Refer to the section "RELATIONSHIP BETWEEN PINS AND CONTROL REGISTERS".

SLPTHR

This is the "through mode" control pin for the transmit slope filter. In the "through mode", the filter is halted and data is directly output. A logic "0" selects the normal mode (slope filter operation) and a logic "1" selects the "through mode". The slope filter decreases noises of low frequencies and improves speech quality. Refer to the slope filter frequency characteristics. Because data is shifted into this pin in synchronization with the rising edge of the SYNC signal, hold the data at the pin for 250 μ s or longer. For further details, refer to the electrical characteristics. This pin is ORed with the CR1-B1 bit of the control register. Refer to the section "RELATIONSHIP BETWEEN PINS AND CONTROL REGISTERS".

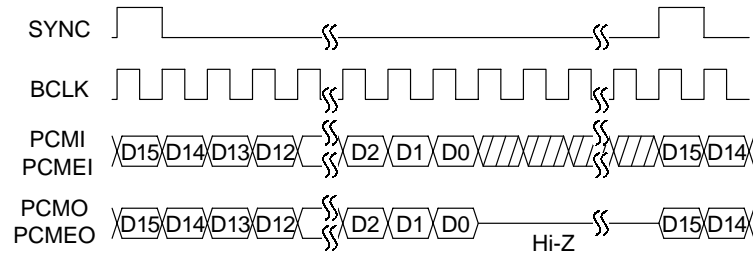

(a) 16-bit linear coding format timing (normal sync)

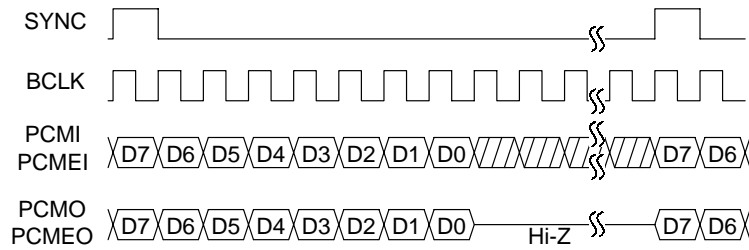

(b) μ-law PCM coding format timing (normal sync)

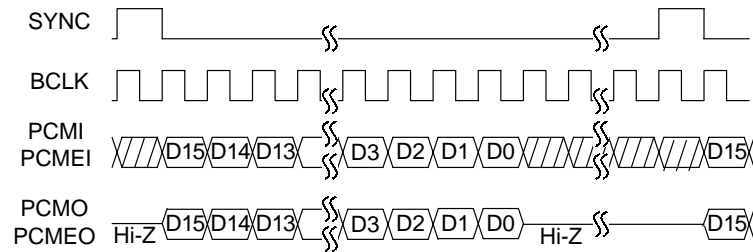

(c) 16-bit linear coding format timing (short-frame sync)

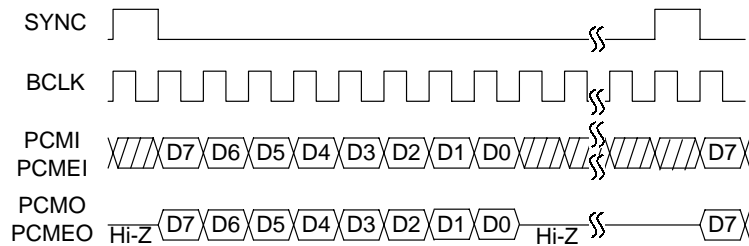

(d) μ-law PCM coding format timing (short-frame sync)

Figure 3 Digital Interface Timing

ECSEL

This is the echo canceler mode selection pin. A logic “1” selects the single echo canceler mode and a logic “0” selects the dual echo canceler mode. If the pin setting is changed, reset must be activated by either the $\overline{\text{PDN/RST}}$ pin or the PDN/RST bit (CR0-B7). If the single echo canceler mode is selected, echo canceler control on the line-side is unnecessary. This pin is ORed with the CR0-B0 bit of the control register. Refer to the section “RELATIONSHIP BETWEEN PINS AND CONTROL REGISTERS”.

LTHR/ATHR

This is the “through mode” control pin for the echo canceler. In the “through mode”, SinL/A and RinL/A data is directly output to SoutL/A and RoutL/A respectively while each respective echo coefficient is maintained. A logic “0” selects the normal mode (echo canceler operation) and a logic “1” selects the “through mode”. In the through mode, the functions of HD, HLD, ATT and GC are invalid. Because data is shifted into this pin in synchronization with the rising edge of the SYNC signal, hold the data at the pin for 250 μs or longer. This pin is ORed with the CR4-B7 and CR5-B7 bits of the control register. Refer to the section “RELATIONSHIP BETWEEN PINS AND CONTROL REGISTERS”.

 $\overline{\text{LHD/AHD}}$

This pin turns ON or OFF the function to detect and cancel the howling that occurs in an acoustic system such as a handsfree communication system. A logic “0” turns the function ON and a logic “1” turns the function OFF. This function is valid when the LTHR/ATHR pin is in the normal mode. Because data is shifted into this pin in synchronization with the rising edge of the SYNC signal, hold the data at the pin for 250 μs or longer. This pin is ORed with the CR4-B4 and CR5-B4 bits of the control register. Refer to the section “RELATIONSHIP BETWEEN PINS AND CONTROL REGISTERS”.

 $\overline{\text{LATT}}$

This pin turns ON or OFF the ATT function to prevent howling by means of attenuators (ATTsL, ATTrL) provided in the RinL inputs and SoutL outputs of the echo canceler. A logic “0” turns ON and a logic “1” turns OFF the ATT function. If input is only to RinL, the ATTsL for SoutL is activated. If input is only to SinL, or if there is input to both SinL and RinL, the ATTrL for RinL input is activated. The ATT value of each attenuator is approximately 6 dB. This function is valid when the LTHR pin is in the normal mode. Because data is shifted into this pin in synchronization with the rising edge of the SYNC signal, hold the data at the pin for 250 μs or longer. This pin setting is logically ORed with the CR4-B1 bit of the control register. Refer to the section “RELATIONSHIP BETWEEN PINS AND CONTROL REGISTERS”.

 $\overline{\text{AATT}}$

This is the ATT attenuation selection pin to prevent howling by means of attenuators (ATTsA, ATTrA) provided in the RinA inputs and SoutA outputs of the echo canceler. A logic “0” selects 6 dB and a logic “1” selects 12 dB. If input is only to RinA, the ATTsA for SoutA is activated. If input is only to SinA, or if there is input to both SinA and RinA, the ATTrA for RinA input is activated. This function is valid when the ATHR pin is in the normal mode. Because data is shifted into this pin in synchronization with the rising edge of the SYNC signal, hold the data at the pin for 250 μs or longer. This pin setting is logically ORed with the CR5-B1 bit of the control register. Refer to the section “RELATIONSHIP BETWEEN PINS AND CONTROL REGISTERS”.

LGC/AGC

This pin turns ON or OFF the gain control function to control the input level and prevent howling by means of gain controls (GainL/A) provided in the RinL/A inputs of the echo canceler. The gain controller adjusts the RinL/A input level when it is -10 dBm₀ or above, and it has the control range of 0 to -8.5 dB. A logic “0” turns the function ON and a logic “1” turns the function OFF. This function is valid when the LTHR/ATHR pin is in the normal mode. Because data is shifted into this pin in synchronization with the rising edge of the SYNC signal, hold the data at the pin for 250 μ s or longer. This pin is ORed with the CR4-B0 and CR5-B0 bits of the control register. Refer to the section “RELATIONSHIP BETWEEN PINS AND CONTROL REGISTERS”.

Notes:

Lxx/Axx : In the above, Lxx refers to line echo canceler control pins and Axx to acoustic echo canceler control pins.

xxL/xxA : In the above pin descriptions, xxL refers to line echo canceler functions and xxA to acoustic echo canceler functions.

GLPADTHR

This is the mode control pin for the attenuators (LPADL/A) provided in the SinL/A inputs and the amplifiers (GPADL/A) provided in the SoutL/A outputs of the echo canceler. A logic “0” selects the “through mode” and a logic “1” selects the normal mode (PAD operation). The levels are set by the CR10 register. Settings of ± 18 , ± 12 , ± 6 and 0 dB are possible. The default setting is ± 12 dB. If the echo return loss (value of returned echo) is amplified, set the LPAD level such that echo return loss will be attenuated. It is recommended to set the GPAD level to the positive level equal to the LPAD level. If the pin setting is changed, the coefficient reset must be activated by either the $\overline{\text{RST}}$ pin or the RST bit (CR0-B6). Because data is shifted into this pin in synchronization with the rising edge of the SYNC signal, hold the data at the pin for 250 μ s or longer. This pin is ORed with the CR1-B2 bit of the control register. Refer to the section “RELATIONSHIP BETWEEN PINS AND CONTROL REGISTERS”.

RST

This input pin resets coefficients of the echo canceler and noise canceler. A logic “0” causes the reset state to be entered. At this time, the filter coefficients for the echo canceler and noise canceler are reset. Control register contents are preserved. While reset is being processed, there is not sound. During normal operation, set this pin to a logic “1”. Use this pin in cases where the echo path changes (due to line switching during a telephone conversation, etc.), or when resuming telephone communication. Because data is shifted into this pin in synchronization with the rising edge of the SYNC signal, hold the data at the pin for 250 μ s or longer. This pin is ORed (negative logic) with the CR0-B6 bit of the control register. Refer to the section “RELATIONSHIP BETWEEN PINS AND CONTROL REGISTERS”.

NCSEL1, NCSEL2

These are the noise attenuation selection pins. In the “through mode” the noise canceler is halted and data is directly output. In the “normal mode” the noise canceler operates normally. Since the noise attenuation in the normal mode is selected after the initial mode has been released, the change of the noise attenuation during normal operation is invalid. If the noise attenuation is changed, reset must be activated by the $\overline{\text{RDN/RST}}$ pin or the PDN/RST bit (CR0-B7). Changing to the through mode during normal operation and returning to the normal mode are possible. The NCSEL1 pin is ORed with the CR1-B0 bit of the control register and the NCSEL2 pin is ORed with the CR12-B2 bit of the control register. Refer to the section “RELATIONSHIP BETWEEN PINS AND CONTROL REGISTERS”.

Note:

Since there is a trade-off between noise attenuation and sound quality after canceling the noise, select the noise attenuation appropriate to the sound quality.

NCSEL2	NCSEL1	NC Mode	Attenuation (dB)	Quality
0	0	Normal Mode	17	Better ↕
1	1	Normal Mode	13.5	
1	0	Normal Mode	8	Best
0	1	Through Mode	—	—

NCPAD1, NCPAD2

These are the noise canceler I/O gain adjusting pins. The gain adjustment is valid for tone control after canceling the noise. The bigger the input level of the noise canceler is, the better the sound quality is. The NCPAD1 pin is ORed with the CR4-B2 bit of the control register and the NCPAD2 pin is ORed with the CR5-B2 bit of the control register. Refer to the section “RELATIONSHIP BETWEEN PINS AND CONTROL REGISTERS”.

NCPAD2	NCPAD1	GPADNC (dB)	LPADNC (dB)
0	0	0	0
0	1	6	-6
1	0	12	-12
1	1	18	-18

 $\overline{\text{DEN}}$, EXCK, DIN, DOUT

This is the serial port for the microcontroller interface. 13 bytes of control registers are provided in this IC device. These pins are used to write and read data from an external microcontroller. The $\overline{\text{DEN}}$ pin is an enable signal input pin, the EXCK pin is a clock signal input pin for data shifting, the DIN pin is an address and data input pin, the DOUT pin is a data output pin. If the microcontroller interface is not used, set the $\overline{\text{DEN}}$ pin to a logic “1” and the EXCK and DIN pins to a logic “0”. In addition, use the MCUSEL pin to specify the “unused” setting of the microcontroller interface. Figure 4 shows the input timing.

MCUSEL

This pin selects whether the microcontroller interface is used or unused. A logic “0” specifies that the microcontroller interface is used and a logic “1” specifies that it is not used. If the microcontroller interface is not used, this pin must be set to a logic “1”. This pin is ORed with the CR0-B1 bit of the control register. Refer to the section “RELATIONSHIP BETWEEN PINS AND CONTROL REGISTERS”.

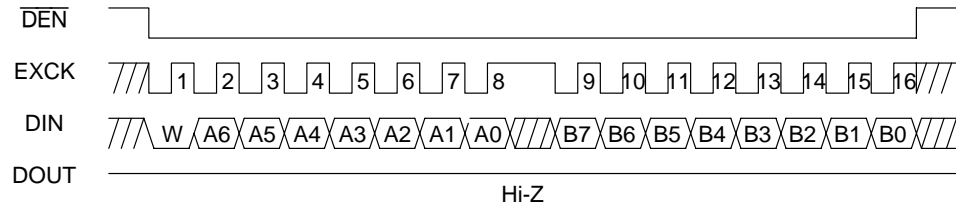

(a) Data Write Timing 1 (8-bit MCU)

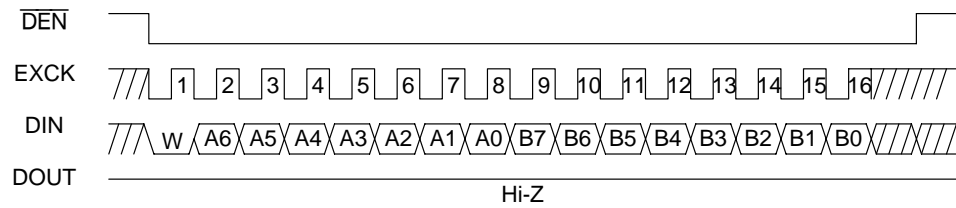

(b) Data Write Timing 2 (16-bit MCU)

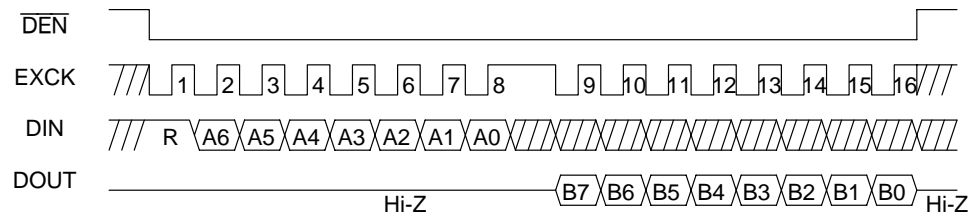

(c) Data Read Timing 1 (8-bit MCU)

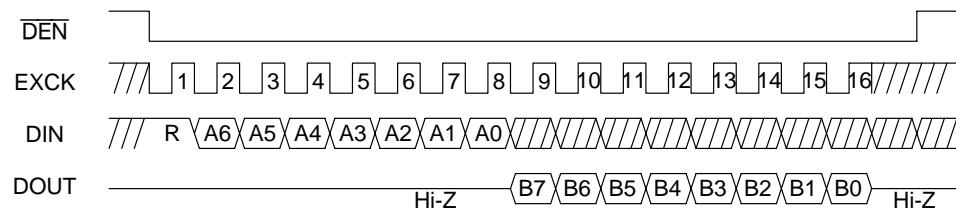

(d) Data Read Timing 2 (16-bit MCU)

Figure 4 Microcontroller Interface I/O Timing

RPAD4, RPAD3, RPAD2, RPAD1

These are the receive signal gain adjusting and mute setting pins. Refer to Table 1 for the settings. Set these pins to a logic “0” when controlling by the control register. Because data is shifted into this pin in synchronization with the rising edge of the SYNC signal, hold the data at the pin for 250 μ s or longer. For further details, refer to the electrical characteristics. These pins are ORed with the CR2-B3, B2, B1 and B0 bits of the control register. Refer to the section “RELATIONSHIP BETWEEN PINS AND CONTROL REGISTERS”.

TPAD4, TPAD3, TPAD2, TPAD1

These are the transmit signal gain adjusting and mute setting pins. Refer to Table 1 for the settings. Set these pins to a logic “0” when controlling by the control register. Because data is shifted into this pin in synchronization with the rising edge of the SYNC signal, hold the data at the pin for 250 μ s or longer. For further details, refer to the electrical characteristics. These pins are ORed with the CR3-B3, B2, B1 and B0 bits of the control register. Refer to the section “RELATIONSHIP BETWEEN PINS AND CONTROL REGISTERS”.

Table 1 RPAD/TPAD Setting

RPAD4	RPAD3	RPAD2	RPAD1	TPAD4	TPAD3	TPAD2	TPAD1	Level
0	1	1	1	0	1	1	1	21 dB
0	1	1	0	0	1	1	0	18 dB
0	1	0	1	0	1	0	1	15 dB
0	1	0	0	0	1	0	0	12 dB
0	0	1	1	0	0	1	1	9 dB
0	0	1	0	0	0	1	0	6 dB
0	0	0	1	0	0	0	1	3 dB
0	0	0	0	0	0	0	0	0 dB
1	1	1	1	1	1	1	1	-3 dB
1	1	1	0	1	1	1	0	-6 dB
1	1	0	1	1	1	0	1	-9 dB
1	1	0	0	1	1	0	0	-12 dB
1	0	1	1	1	0	1	1	-15 dB
1	0	1	0	1	0	1	0	-18 dB
1	0	0	1	1	0	0	1	-21 dB
1	0	0	0	1	0	0	0	MUTE

TEST1-4

Test inputs. Set these pins to a logic “0”.

TEST9

Test output.

ABSOLUTE MAXIMUM RATINGS

Parameter	Symbol	Condition	Rating	Unit
Power Supply Voltage	V_{DD}	—	-0.3 to +5.0	V
Analog/Digital Input Voltage	V_{IN}	—	-0.3 to $V_{DD}+0.3$	V
Analog/Digital output Voltage	V_{OUT}	—	-0.3 to $V_{DD}+0.3$	V
Storage Temperature	T_{STG}	—	-55 to +150	°C

RECOMMENDED OPERATING CONDITION

Parameter	Symbol	Condition	Min.	Typ.	Max.	Unit
Power Supply Voltage	V_{DD}	—	2.7	—	3.6	V
Operating Temperature	T_a	—	-40	+25	+85	°C
Input High Voltage	V_{IH}	SYNC, BCLK input pins	$0.5 \times V_{DD}$	—	V_{DD}	V
		MCK/X1 input pin	$0.65 \times V_{DD}$			
		Other digital input pins	$0.45 \times V_{DD}$			
Input Low Voltage	V_{IL}	MCK/X1 input pin	0	—	$0.35 \times V_{DD}$	V
		Other digital input pins			$0.16 \times V_{DD}$	
Digital Input Rise Time	t_{IR}	All digital inputs	—	—	20	ns
Digital Input Fall Time	t_{IF}	All digital inputs	—	—	20	ns
Master Clock Frequency	f_{MCK}	MCK/X1	-100 ppm	+19.2	+100 ppm	MHz
Master Clock Duty Ratio	D_{MCK}	MCK/X1	40	50	60	%
Bit Clock Frequency	f_{BCK}	BCLK (during input)	64	—	2048	kHz
Bit Clock Duty Ratio	D_{CK}	BCLK (during input)	40	50	60	%
Synchronous Signal Frequency	f_{SYNC}	SYNC (during input)	-100 ppm	8	+100 ppm	kHz
Synchronous Signal Width	t_{WS}	SYNC (during input)	1 BCLK	—	100	μs
Transmit/Receive Sync Signal Setting Time	t_{BS}	BCLK to SYNC (during input)	100	—	—	ns
	t_{SB}	SYNC to BCLK (during input)	100	—	—	ns
Digital Output Load	R_{DL}	DOUT, PCMO, PCME0	1	—	—	kΩ
	C_{DL1}	DOUT, PCMO, PCME0	—	—	50	pF
	C_{DL2}	SYNC, BCLK (during output)	—	—	20	pF
Bypass Condenser for SG	C_{SG}	SG to AG	10+0.1	—	—	μF

ELECTRICAL CHARACTERISTICS**DC Characteristics**(V_{DD} = 2.7 to 3.6 V, T_a = -40 to +85°C)

Parameter	Symbol	Condition	Min.	Typ.	Max.	Unit
Power Supply Current 1	I _{DD1}	Operating, no signal (V _{DD} = 3.0 V)	—	35	50	mA
Power Supply Current 2	I _{DD2}	Power down mode (V _{DD} = 3.0 V, MCK = 0 V)	—	0.02	1	mA
Input Leakage Current	I _{IH}	V _i = V _{DD}	—	—	2	μA
	I _{IL}	V _i = 0 V	—	—	2	μA
High Level Digital Output Voltage	V _{OH}	I _{OH} = 0.4 mA (other than x2)	0.7×V _{DD}	—	V _{DD}	V
Low Level Digital Output Voltage	V _{OL}	I _{OL} = 3.2 mA (other than x2)	—0	0.2	0.4	V
Digital Output Leakage Current	I _O	DOUT, PCMO, PCME0	—	—	10	μA
Input Capacitance	C _{IN}	—	—	5	—	pF

Analog Interface Characteristics(V_{DD} = 2.7 to 3.6 V, T_a = -40 to +85°C)

Parameter	Symbol	Condition	Min.	Typ.	Max.	Unit	
Input Resistance	R _{INA}	AIN, APWI	10	—	—	MΩ	
	R _{INL}	LIN, LPWI	10	—	—	MΩ	
Output Load Resistance	R _{LA1}	AGSX, AVFRO	20	—	—	kΩ	
	R _{LA2}	AOUT	1.2	—	—	kΩ	
	R _{LL1}	LGSX, LVFRO	20	—	—	kΩ	
	R _{LL2}	LOUT	1.2	—	—	kΩ	
Output Load Capacitance	C _{LA1}	AGSX, AVFRO, AOUT	—	—	100	pF	
	C _{LL1}	LGSX, LVFRO, LOUT	—	—	100	pF	
Output Voltage Level (*1)	V _{OA1}	AGSX, AVFRO	R _L = 20 kΩ	—	—	1.3	V _{pp}
	V _{OA2}	AOUT	R _L = 1.2 kΩ	—	—	2.6	V _{pp}
	V _{OL1}	LGSX, LVFRO	R _L = 20 kΩ	—	—	1.3	V _{pp}
	V _{OL2}	LOUT	R _L = 1.2 kΩ	—	—	2.6	V _{pp}
Offset Voltage	V _{OFA1}	AVFRO	—100	—	+100	mV	
	V _{OFA2}	AOUT	-20	—	+20	mV	
	V _{OFL1}	LVFRO	-100	—	+100	mV	
	V _{OFL2}	LOUT	-20	—	+20	mV	
SG Output Voltage	V _{SG}	SG	—	1.4	—	V	
SG Output Impedance	R _{SG}	SG	—	40	80	kΩ	

Note*1: 0.320 V_{rms} = 0 dBm₀, +3.14 dBm₀ = 1.30 V_{pp}

Digital Interface Characteristics (1/3)

(V_{DD} = 2.7 to 3.6 V, T_a = -40 to +85°C)

Parameter	Symbol	Condition	Min.	Typ.	Max.	Unit
Power-down/Reset Signal Pulse Width	t _{RSTW}	PDN/RST pin	1	—	—	μS
		PDN/RST control bit	1.6	—	—	
Power-down/Reset Start Time	t _{PDND}	PDN/RST pin and PDN/RST control bit	—	—	50	nS
Power down/Reset End Time	t _{PDNH}	PDN/RST pin and PDN/RST control bit	—	—	200+α	mS
Power-down/Reset Internal Setting Time	t _{PDNS}	SYNC pin (input mode)	140	—	180	μS
Control Pulse Width	t _{PARW}	(*2)	250	—	—	μS
Control Start Time	t _{PARD}		—	—	250	μS
Control End Time	t _{PARH}		—	—	250	μS

α: Crystal activation

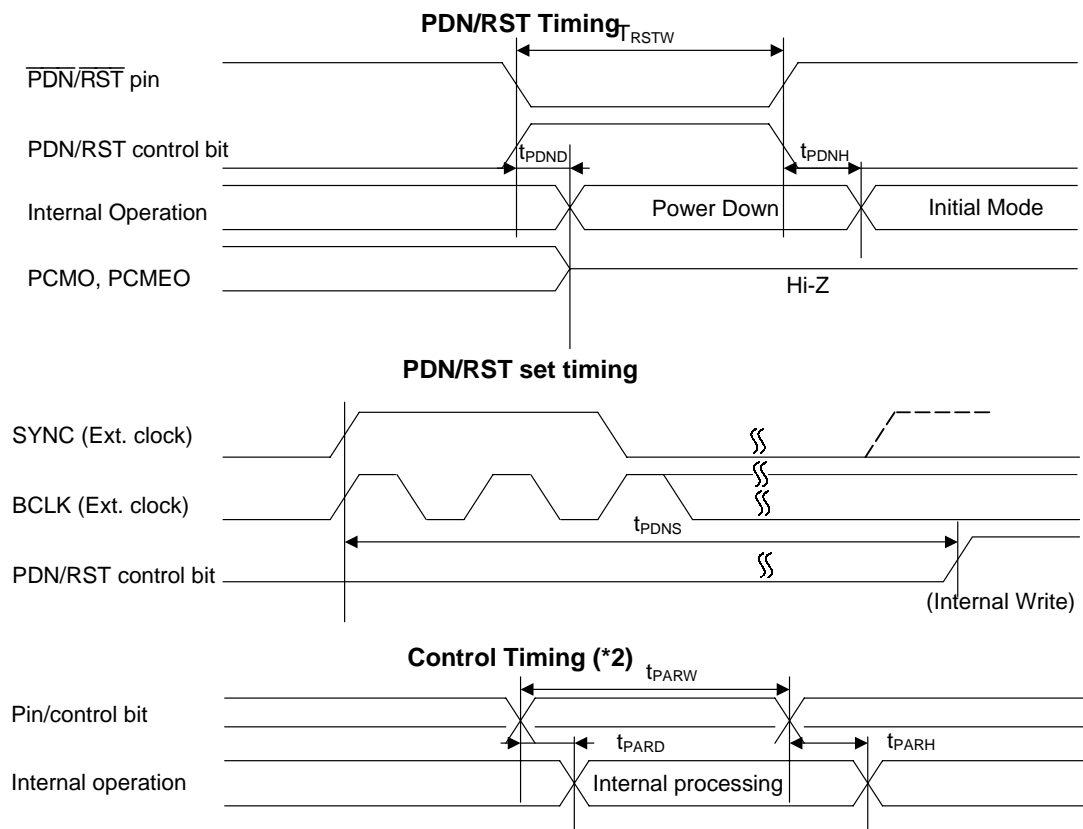

Note*2: Applies to the following pins/control bits:

LINEEN, SLPTHR, NCTHR, GLPADTHR, TPAD6-1, RPAD6-1, RST, ATHR, AATT, AHLD, AHD, AGC, LTHR, LATT, LHLD, LHD, LGC pins, and control bits.

Digital Interface Characteristics (2/3) $(V_{DD} = 2.7 \text{ to } 3.6 \text{ V}, T_a = -40 \text{ to } +85^\circ\text{C})$

Parameter	Symbol	Condition	Min.	Typ.	Max.	Unit
Bit Clock Frequency	f_{BCK}	$C_{DL} = 20 \text{ pF}$ (output mode, PCM)	—	64	—	kHz
		$C_{DL} = 20 \text{ pF}$ (output mode, linear)	—	128	—	kHz
Bit Clock Duty Ratio	D_{CK}	$C_{DL} = 20 \text{ pF}$ (output mode)	40	50	60	%
Sync signal frequency	f_{SYNC}	$C_{DL} = 20 \text{ pF}$ (output mode)	—	8	—	kHz
Sync signal Duty Ratio	D_{SYNC}	$C_{DL} = 20 \text{ pF}$ (output mode)	40	50	60	%
Transmit/Receive Sync Signal Setting Time	t_{BS}	BCLK to SYNC (output mode)	100	—	—	ns
	t_{SB}	SYNC to BCLK (output mode)	100	—	—	ns
Input Setup Time	t_{DS}	—	100	—	—	ns
Input Hold Time	t_{DH}	—	100	—	—	ns
Digital Output Delay Time	t_{SDX}	$R_{DL} = 1 \text{ k}\Omega, C_{DL} = 50 \text{ pF}$	—	—	100	ns
	t_{XD1}	$R_{DL} = 1 \text{ k}\Omega, C_{DL} = 50 \text{ pF}$	—	—	100	ns
Digital Output Hold Time	t_{XD2}	$R_{DL} = 1 \text{ k}\Omega, C_{DL} = 50 \text{ pF}$	—	—	100	ns
	t_{XD3}	$R_{DL} = 1 \text{ k}\Omega, C_{DL} = 50 \text{ pF}$	—	—	100	ns

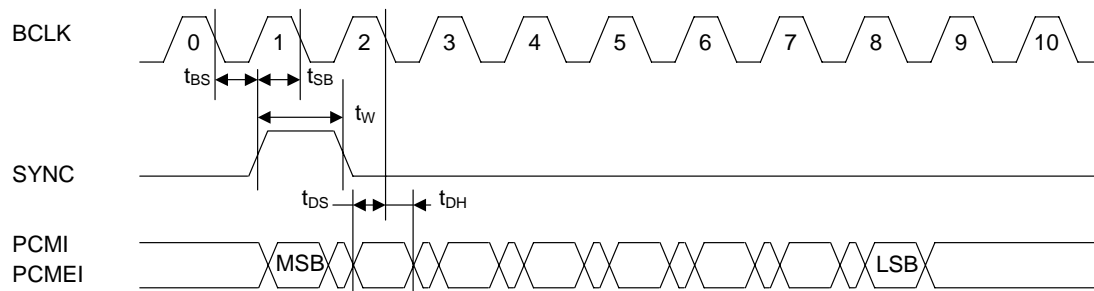
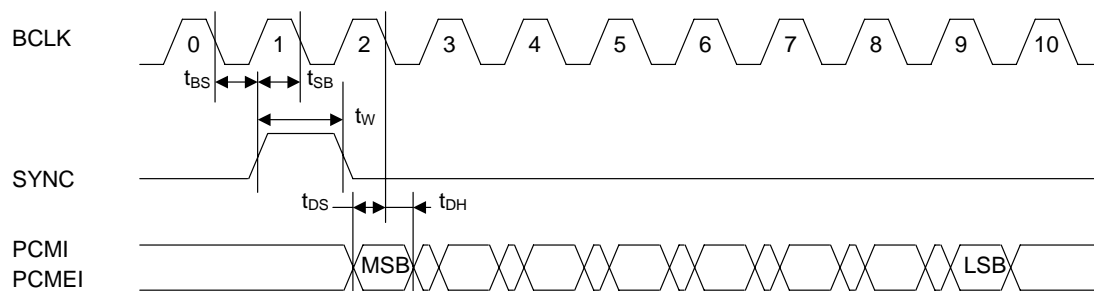
Digital Input Timing (Normal-sync)**Digital Input Timing (Short-frame-sync)**

Digital Output Timing (Normal-sync)

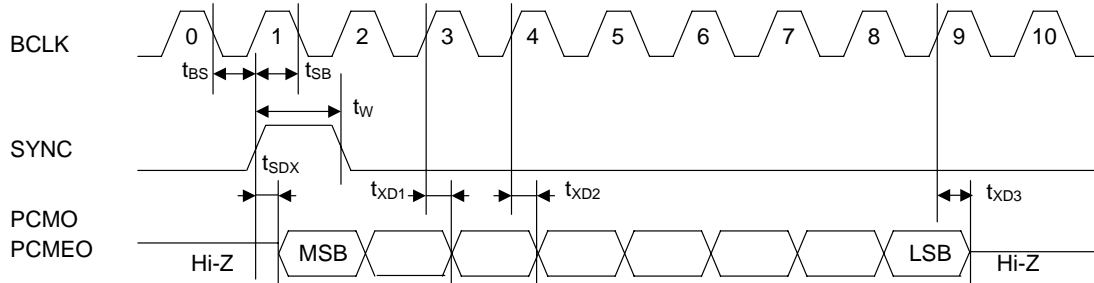

Digital Output Timing (Short-frame-sync)

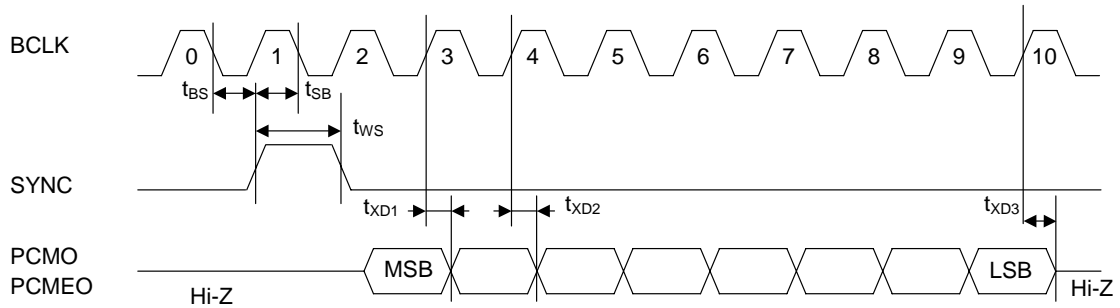

Digital Interface Characteristics (3/3)

($V_{DD} = 2.7$ to 3.6 V, $T_a = -40$ to $+85^\circ\text{C}$)

Parameter	Symbol	Condition	Min.	Typ.	Max.	Unit
MCU Interface Digital Input/Output Setting Time	t_{M1}	—	20	—	—	ns
	t_{M2}	—	20	—	—	ns
	t_{M3}	—	50	—	—	ns
	t_{M4}	—	100	—	—	ns
	t_{M5}	—	50	—	—	ns
	t_{M6}	—	50	—	—	ns
	t_{M7}	$R_D = 1\text{ k}\Omega, C_{DL} = 20\text{ pF}$	—	—	30	ns
	t_{M8}	$R_D = 1\text{ k}\Omega, C_{DL} = 20\text{ pF}$	0	—	—	ns
	t_{M9}	—	50	—	—	ns
	t_{M10}	$R_D = 1\text{ k}\Omega, C_{DL} = 20\text{ pF}$	—	—	30	ns
	t_{M11}	—	100	—	—	ns
EXCK Clock Frequency	f_{EXCK}	—	—	—	10	MHz

Microcontroller Interface I/O Timing

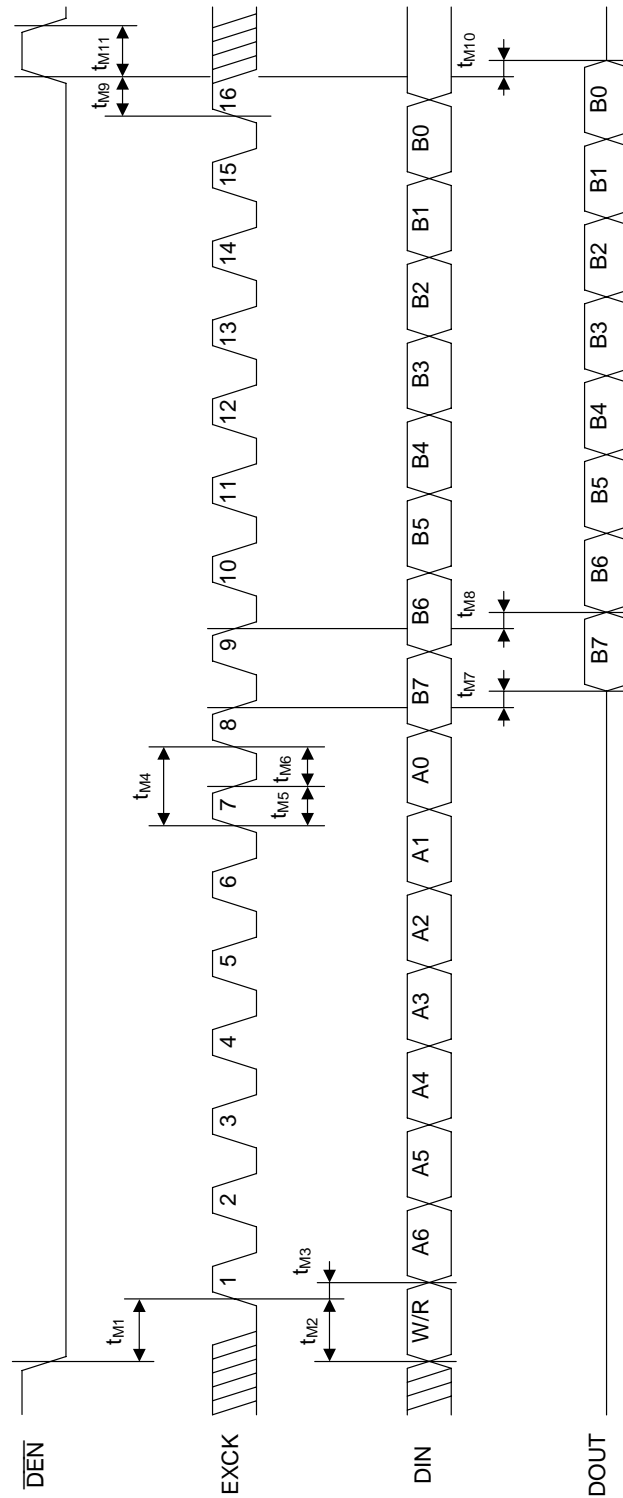

AC Characteristic (Line side CODEC/Acoustic side CODEC)

(V_{DD} = 2.7 to 3.6 V, T_a = -40 to +85°C)

Parameter	Symbol	Condition			Min.	Typ.	Max.	Unit
		Freq. (Hz)	Level (dBm0)	Others				
Transmit Frequency Response	L _{oss} T1	0 to 60	0	(*3)	25	—	—	dB
	L _{oss} T2	300 to 3000			-0.15	—	+0.20	
	L _{oss} T3	1020			Reference			
	L _{oss} T4	3300			-0.15	—	+0.80	
	L _{oss} T5	3400			0	—	0.80	
	L _{oss} T6	3968.75			13	—	—	
Receive Frequency Response	L _{oss} R1	0 to 3000	0	(*3)	-0.15	—	+0.20	dB
	L _{oss} R2	1020			Reference			
	L _{oss} R3	3300			-0.15	—	+0.80	
	L _{oss} R4	3400			0	—	0.80	
	L _{oss} R5	3968.75			13	—	—	
Transmit Signal to Distortion Ratio	SD T1	1020	3	(*3, *4)	35	—	—	dB
	SD T2		0		35	—	—	
	SD T3		-30		35	—	—	
	SD T4		-40		28	—	—	
	SD T5		-45		23	—	—	
Receive Signal to Distortion Ratio	SD R1	1020	3	(*3, *4)	35	—	—	dB
	SD R2		0		35	—	—	
	SD R3		-30		35	—	—	
	SD R4		-40		28	—	—	
	SD R5		-45		23	—	—	
Transmit Gain Tracking	GT T1	1020	3	(*3)	-0.2	—	+0.2	dB
	GT T2		-10		Reference			
	GT T3		-40		-0.2	—	+0.2	
	GT T4		-50		-0.5	—	+0.5	
	GT T5		-55		-1.2	—	+1.2	
Receive Gain Tracking	GT R1	1020	3	(*3)	-0.2	—	+0.2	dB
	GT R2		-10		Reference			
	GT R3		-40		-0.2	—	+0.2	
	GT R4		-50		-0.5	—	+0.5	
	GT R5		-55		-1.2	—	+1.2	
Idle Channel Noise	N _{IDLT}	—	—	(*3, *4)	—	—	-68 (-75.7)	dBm0p (dBmp)
	N _{IDLR}	—	—	(*3, *4)	—	—	-72 (-79.7)	
Absolute Signal Amplitude	A _{VT}	1020	0	A/LGSX (*3)	0.285	0.32	0.359	V _{rms}
	A _{VR}			A/LVFRO (*3)	0.285	0.32	0.359	V _{rms}
Power Supply Noise Rejection Ratio	P _{SRRT}	Noise Freq: 0 to 50 kHz	Noise Level: 50 mV _{PP}	(*3)	30	—	—	dB
	P _{SRRR}				30	—	—	dB

Note: *3. CODEC input/output gain = 1
*4. P-message weighted filter used
0.320 V_{rms} = 0 dBm0 = -7.7 dBm

Noise Canceler Characteristics

($V_{DD} = 2.7$ to 3.6 V, $T_a = -40$ to $+85^\circ\text{C}$)

Parameter	Symbol	Condition	Min.	Typ.	Max.	Unit
Noise Attenuation	N_{res}	White Noise, voice band	13	17	—	dB

Measurement System Block Diagram

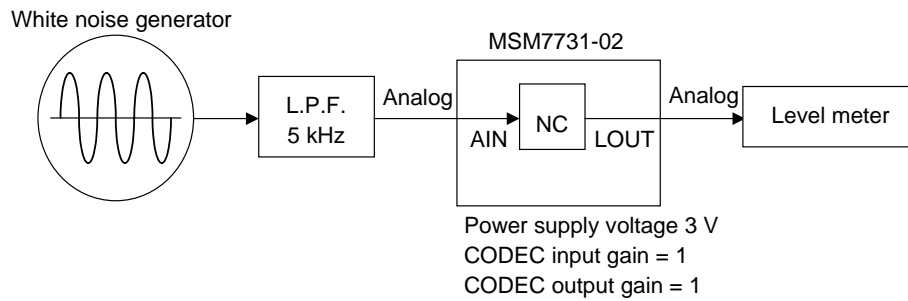

Echo Canceler Characteristics

($V_{DD} = 2.7$ to 3.6 V, $T_a = -40$ to $+85^\circ\text{C}$)

Parameter	Symbol	Condition	Min.	Typ.	Max.	Unit
Echo Attenuation	E_{res}	Acoustic Line side (when CODEC or 16-bit linear data interface is used)	—	35	—	dB
		Line side (μ -law PCM used)	—	30	—	dB
Cancelable Echo Delay Time	T_{acoud}	Single mode	—	—	59	mS
	T_{acoud}	Dual mode (acoustic side)	—	—	$59 - T_{lined}$	mS
	T_{lined}	Dual mode (line side)	—	—	27	mS

Measurement System Block Diagram

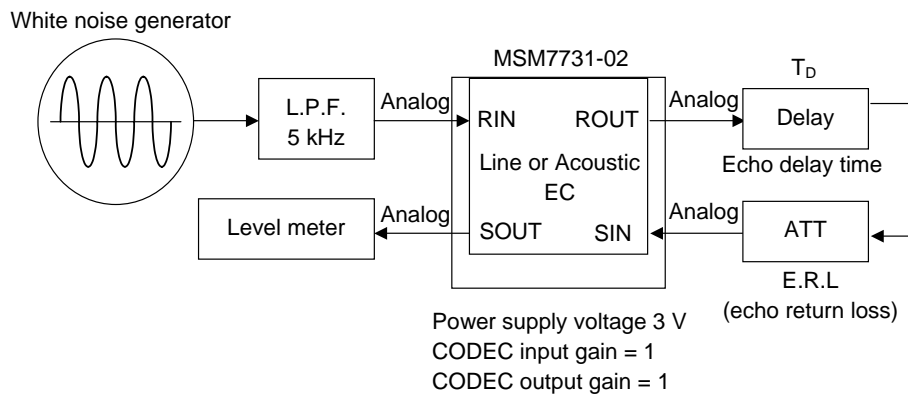

Rin input level vs. echo attenuation

(Measuring Conditions) Rin signal : 5 kHz band white noise
 E.R.L : -6 dB
 Delay time : 4 ms
 ATT, GC : OFF
 Noise floor : -60 dBm (P-message filter unused)

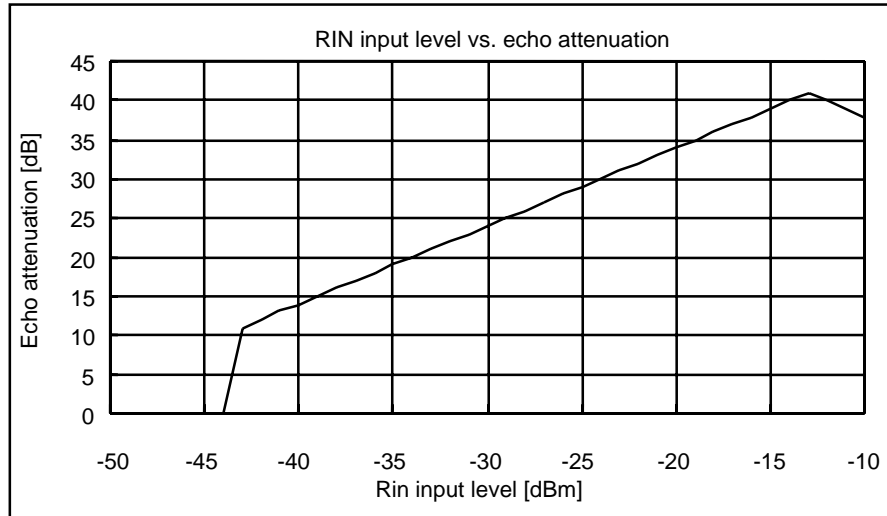

E.R.L level vs. echo attenuation (with GLPAD)

(Measuring Condition) Rin signal : 5 kHz band white noise
 Rin input level : -20 dBm (with GLPAD = ±0 dB)
 : -26 dBm (with GLPAD = ±6 dB)
 : -32 dBm (with GLPAD = ±12 dB)
 : -38 dBm (with GLPAD = ±18 dB)
 Delay time : 4 ms
 ATT, GC : OFF
 Noise floor : -60 dBm (P-message filter unused)

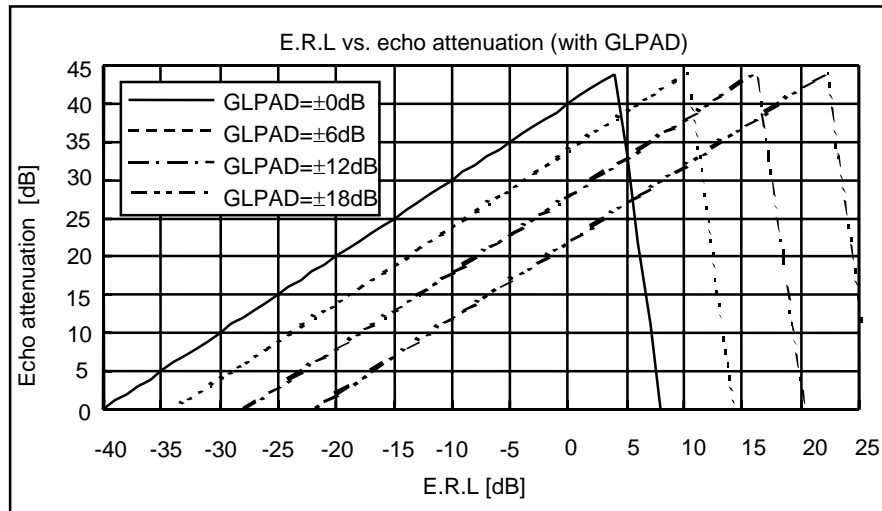

Echo delay time vs. echo attenuation (Dual echo canceler mode/acoustic side)

(Measuring Condition) Rin signal : 5 kHz band white noise
 Rin input level : -16 dBm
 E.R.L : -6 dB
 ATT, GC : OFF
 Noise floor : -60 dBm (P-message filter unused)

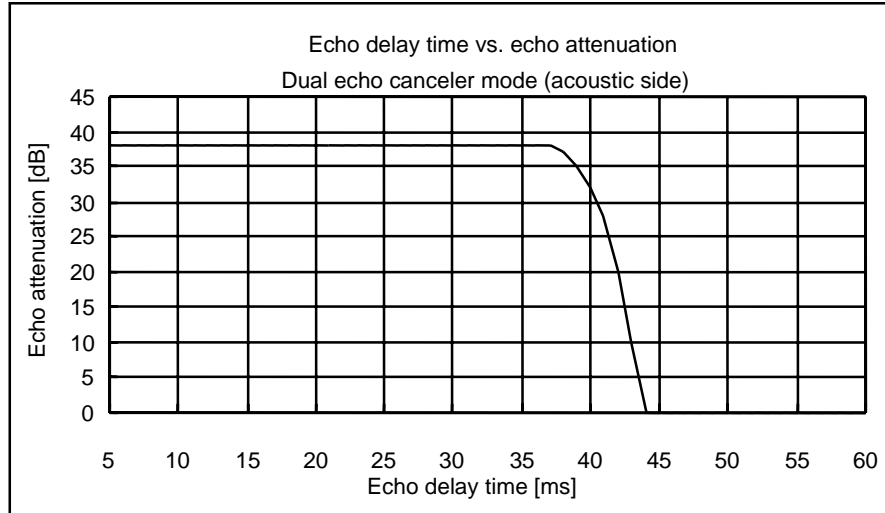

Echo delay time vs. echo attenuation (Dual echo canceler mode/line side)

(Measuring Condition) Rin signal : 5 kHz band white noise
 Rin input level : -16 dBm
 E.R.L : -6 dB
 ATT, GC : OFF
 Noise floor : -60 dBm (P-message filter unused)

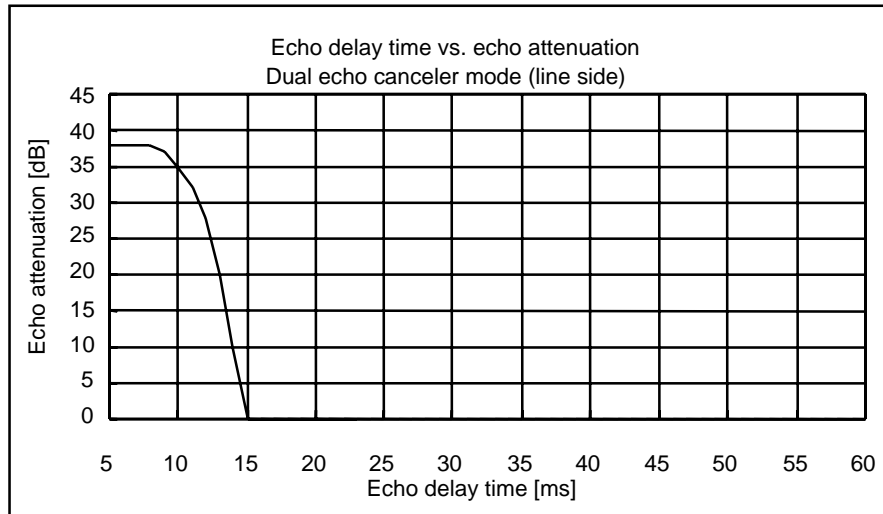

Echo delay time vs. echo attenuation (Single echo canceler mode)

(Measuring Condition) Rin signal : 5 kHz band white noise
 Rin input level : -16 dBm
 E.R.L : -6 dB
 ATT, GC : OFF
 Noise floor : -60 dBm (P-message filter unused)

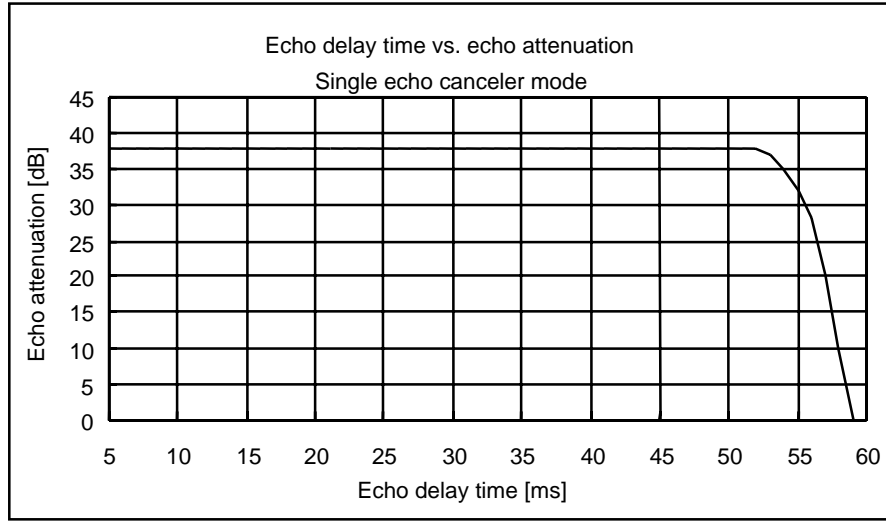

Slope filter frequency characteristic (with CODEC filter frequency characteristic)

(Measuring Condition) Rin input level : -16 dBm
 Noise floor : -60 dBm (P-message filter unused)

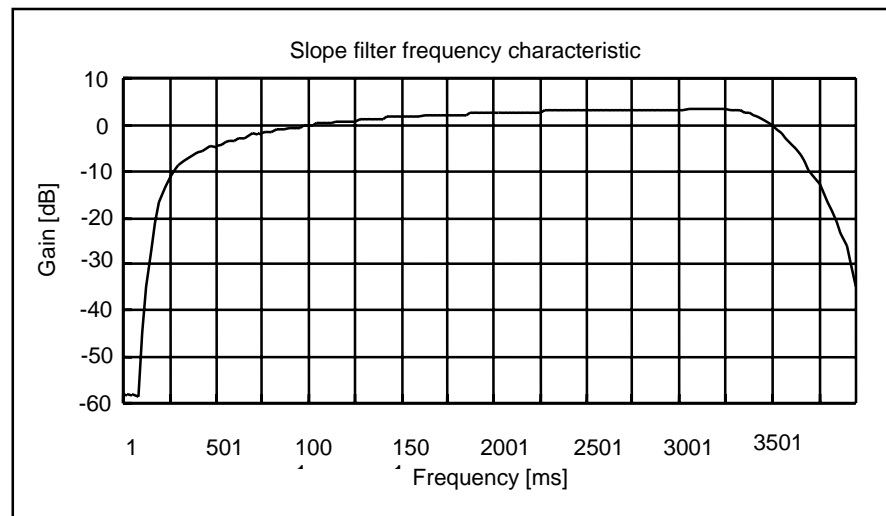

Echo Canceler Characteristics Data 1 (Line Echo, White Noise)

(Measuring Condition) Rin signal : 5 kHz band white noise
 Rin input level : -20 dBm
 E.R.L : 0 dB
 ATT, GC : OFF
 Noise floor : -60 dBm (P-message filter unused)

Echo attenuation = 40 dB

Echo Canceler Characteristics Data 2 (Line Echo, Voice)

(Measuring Condition) Rin signal : voice
 Rin input level : about -20 dBm
 E.R.L : 0 dB
 ATT, GC : OFF
 Noise floor : -60 dBm (P-message filter unused)

Echo attenuation = 34 dB

Echo Canceler Characteristics Data 3 (Acoustic echo, Voice)

(Measuring Condition) Rin signal : voice
 Rin input level : about -20 dBm
 Speaker output level : 80 dB (A) (at 1 m)
 Distance from microphone and speaker : 5 cm
 GC : OFF
 ATT, Noise Canceler : OFF
 Noise floor : -60 dBm (P-message filter unused)

Echo attenuation = 34 dB

Measurement System Block Diagram (Acoustic Echo)

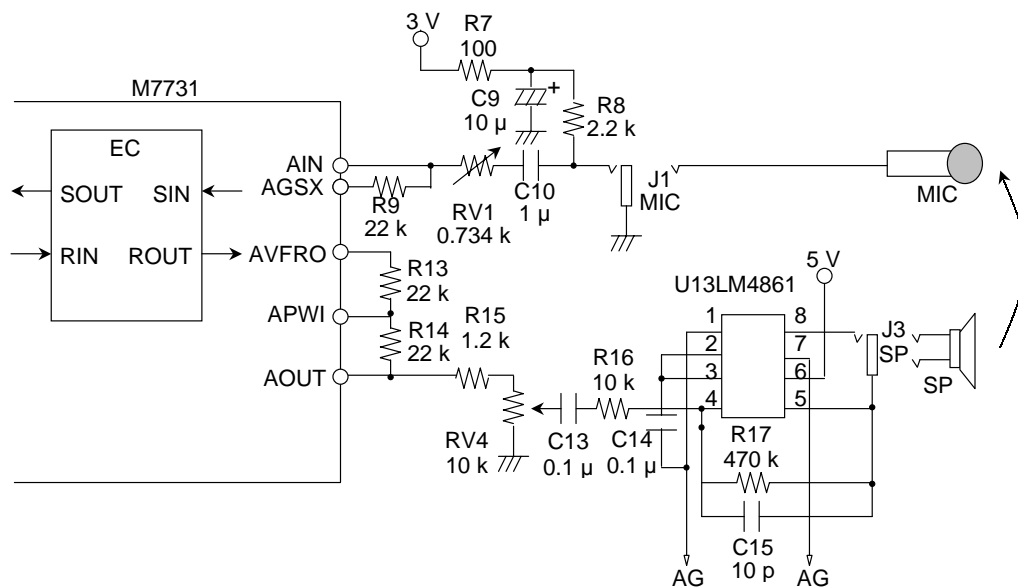

FUNCTIONAL DESCRIPTION

Control Registers

Table 2 Control Register Map

Reg Name	Address								Contents								R/W
	A6	A5	A4	A3	A2	A1	A0	B7	B6	B5	B4	B3	B2	B1	B0		
CR0	0	0	0	0	0	0	0	*PDN/RST	*RST	*#LINEEN	#CLKEN	#PCMEN	#PCMEEN	OPE	OPE	R/W	
CR1	0	0	0	0	0	0	1	#DMWR	—	—	—	—	*GLPADTHR	*SLPTHR	*#NCSEL1	R/W	
CR2	0	0	0	0	0	1	0	—	—	RPAD6	RPAD5	*RPAD4	*RPAD3	*RPAD2	*RPAD1	R/W	
CR3	0	0	0	0	0	1	1	—	—	TPAD6	TPAD5	*TPAD4	*TPAD3	*TPAD2	*TPAD1	R/W	
CR4	0	0	0	0	1	0	0	*LTHR	—	LHLD	*LHD	LCLP	*NCPAD1	*LAT	*LGC	R/W	
CR5	0	0	0	0	1	0	1	*ATHR	—	AHLD	*AHD	ACL	*NCPAD2	*AAT	*AGC	R/W	
CR6	0	0	0	0	1	1	0	A15	A14	A13	A12	A11	A10	A9	A8	R/W	
CR7	0	0	0	0	1	1	1	A7	A6	A5	A4	A3	A2	A1	A0	R/W	
CR8	0	0	0	1	0	0	0	D15	D14	D13	D12	D11	D10	D9	D8	R/W	
CR9	0	0	0	1	0	0	1	D7	D6	D5	D4	D3	D2	D1	D0	R/W	
CR10	0	0	0	1	0	1	0	GPADA2	GPADA1	LPADA2	LPADA1	GPADL2	GPADL1	LPADL2	LPADL1	R/W	
CR11	0	0	0	1	0	1	1	READY	—	—	—	—	—	*#PCMSEL	#SYPDN	R/W	
CR12	0	0	0	1	1	0	0	—	—	—	—	—	*#NCSEL2	—	—	R/W	

Note

- * : Shared control bits with port (pin)
- : Reserved bits. Do not change the initial value ("0").
- # : Control bit that can be changed only in the initial mode.

(1) CR0 (basic operating mode setting)

	B7	B6	B5	B4	B3	B2	B1	B0
CR0	PDN/RST	RST	$\overline{\text{LINEEN}}$	$\overline{\text{CLKEN}}$	$\overline{\text{PCMEN}}$	$\overline{\text{PMCEEN}}$	OPE MCUSEL	OPE ECSEL
Initial Value (*5)	0	0	0	0	0	0	0	0

Note*5: Initial values are the values set when reset is activated by the PDN/RST pin. (Initial values are also set in the same manner, except for CR0-B7, when reset by the PDN/RST bit of B7.)

- B7** Power-down and Reset 0: power-on 1: power-down reset
During power-down reset, this device enters the power-down state. At this time all control register bits, internal variables, and the coefficients for the echo canceler and noise canceler are reset. After power-down reset is released, this device enters the initial mode. This bit is internally ORed with the inverted $\overline{\text{PDN/RST}}$ signal. Refer to the section "RELATIONSHIP BETWEEN PINS AND CONTROL REGISTERS".
- B6** Reset control 0: normal operation 1: reset
At reset, the coefficients for the echo canceler and noise canceler are reset. Control register contents preserved. While reset is being processed, there is no sound. Use this bit in cases where the echo path changes (due to line switching during a telephone conversation, etc.), or when resuming telephone communication. Because data is read by this bit in synchronization with the rising edge of the SYNC signal, hold the data in the bit for 250 μs or longer. This bit is internally ORed with the inverted $\overline{\text{RST}}$ signal. Refer to the section "RELATIONSHIP BETWEEN PINS AND CONTROL REGISTERS".
- B5** Line CODEC power-down control 0: normal operation 1: power-down
During power-down, the line CODEC is in the power-down state, the line CODEC output pin is at high impedance and line CODEC input pin is internally processed as an idle pattern input. This bit is internally ORed with the $\overline{\text{LINEEN}}$ pin. When the line CODEC is not used, this control results in low consumption of electrical power. This bit can only be set to "0" or "1" during power-down reset and initial mode. Refer to the section "RELATIONSHIP BETWEEN PINS AND CONTROL REGISTERS".
- B4** SYNC, BCLK output control 0: ON 1: OFF
When OFF, the SYNC and BCLK output pins are in the high impedance state. This control is valid when the CLKSEL pin is at a logic "0" and has selected the internal clock mode. When the SYNC and BCLK clocks are not used externally, this control results in low consumption of electrical power. This bit can only be set to "0" or "1" during power-down reset and the initial mode.
- B3** PCMI/O control 0: ON 1: OFF
When OFF, the PCMO output pin is in the high impedance state and the PCMI input pin is internally processed as an idle pattern input. When the line digital interface is not used, this control results in low consumption of electrical power. This bit can only be set to "0" or "1" during power-down reset and the initial mode.
- B2** PCMEI/O control 0: ON 1: OFF
When OFF, the PCMEO output pin is in the high impedance state and the PCMEI input pin is internally processed as an idle pattern input. When the line digital interface is not used, this control results in low consumption of electrical power. This bit can only be set to "0" or "1" during power-down reset and the initial mode.

B1, B0 Operation mode selection**(0, 0):** Initial mode

Approximately 200 ms after power-down reset is released, the initial mode is entered.

Only in this mode can the contents of the internal default value store memory be modified and CR0-B5 to CR0-B0, CR1-B7, CR1-B0, CR11-B1, CR11-B0, and CR12-B2 be set. In this mode, digital signal output pins are at high impedance, digital communication input pins are internally processed as idle pattern inputs, and neither the echo canceler nor the noise canceler operates. This mode is skipped when the MCUSEL pin is a logic "1". This mode is released by setting the modes shown below. Refer to the flow chart of Figure 5.

(1, 0): Dual echo canceler mode

The acoustic echo canceler, line echo canceler and other functions can be operated by control from the control registers. Refer to Figure 6.

The initial setting for cancelable echo delay time is as follows:

Acoustic delay time = 44 ms

Line delay time = 15 ms

(1, 1): Single echo canceler mode

The acoustic echo canceler and other functions can be operated by control from the control registers.

Control of the line echo canceler is unnecessary in this mode. Refer to Figure 7.

The initial setting for cancelable echo delay time is as follows:

Acoustic delay time = 59 ms

(Other): Reserved bit (cannot be used)

Note: The MCUSEL pin is internally ORed with B1, and the ECSEL pin is internally ORed with B0. To return to the initial mode after it has been released, activate power-down reset.

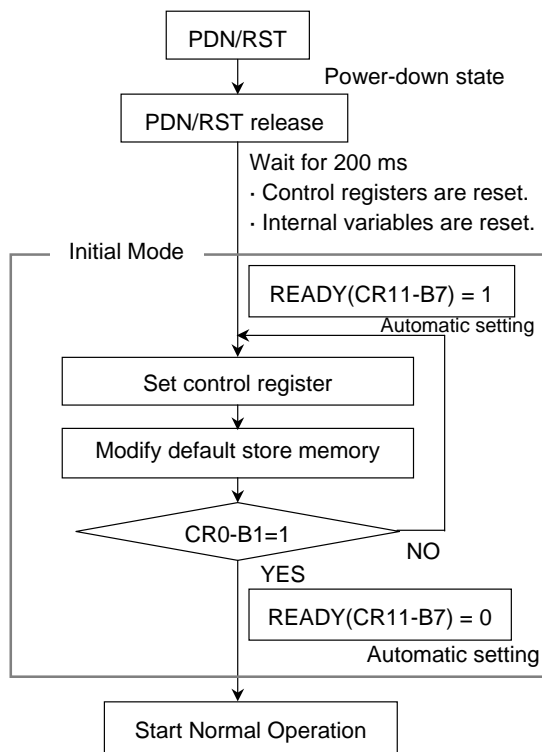

Figure 5 Initial Mode Flowchart

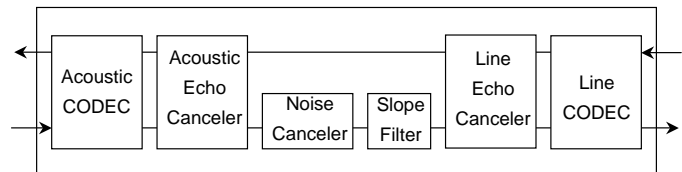

Figure 6 Dual Echo Canceler Mode

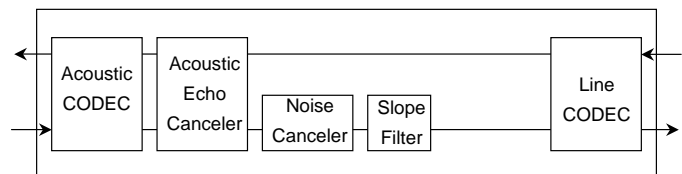

Figure 7 Single Echo Canceler Mode

(2) CR1

	B7	B6	B5	B4	B3	B2	B1	B0
CR1	DMWR	—	—	—	—	GLPADTHR	SLPTHR	NCSEL1
Initial Value	0	0	0	0	0	0	0	0

B7 Internal data memory write control 0: write inhibited 1: write
 In internal data memory, the data set in CR8 (D15 to D8) and CR9 (D7 to D0) is written to the memory address set in CR6 (A15 to A8) and CR7 (A7 to A0).
 Writing is possible only during the initial mode.
 For further details, refer to the internal data memory access method.

B6, B5, B4, B3 Reserved bits. Modification of initial values is inhibited.

B2 Echo Canceled I/O PAD control 0: “through mode” 1: normal mode
 This bit controls the attenuators (LPADL/A) provided in the SinL/A inputs and the amplifiers (GPADL/A) provided in the SoutL/A outputs of the echo canceler. Levels are set by the CR10 register, and ± 18 , ± 12 , ± 6 and 0 dB can be set. The default value is ± 12 dB. Use this bit when the echo return loss (value of returned echo) is amplified. If the pin setting is changed, the coefficient reset must be activated by either the $\overline{\text{RST}}$ pin or the RST bit (CR0-B6). Because data is read by this bit in synchronization with the rising edge of the SYNC signal, hold the data in the bit for 250 μs or longer. This bit is internally ORed with the GLPADTHR pin.

B1 Slope filter control 0: normal mode (slope filter operation) 1: “through mode”
 This bit controls operation of the transmit slope filter. In the “through mode”, the filter is halted and data is output directly. The slope filter decreases noises of low frequencies and improves the speech quality. Refer to the frequency characteristics of slope filter. Because data is read by this bit in synchronization with the rising edge of the SYNC signal, hold the data in the bit for 250 μs or longer. This bit is internally ORed with the SLPTHR pin.

B0 Noise attenuation selection control 0: normal mode 1: “through mode”
 This bit selects the noise attenuation of the noise canceler. In the “through mode”, the noise canceler is halted and data is output directly. In the “normal mode” the noise canceler operates normally. Since the noise attenuation in the normal mode is selected after the initial mode has been released, the change of the noise attenuation during normal operation is invalid. If the noise attenuation is changed, reset must be activated by the $\overline{\text{RDN}}/\overline{\text{RST}}$ pin or the PDN/RST bit (CR0-B7). Changing to the through mode during normal operation and returning to the normal mode are possible. This bit is internally ORed with NCSEL1 pin. (Refer to the NCSEL2 pin of CR12-B2.)

Note: Since there is a trade-off between noise attenuation and sound quality after canceling the noise, select the noise attenuation appropriate to the sound quality.

NCSEL2	NCSEL1	NC Mode	Attenuation (dB)	Quality
0	0	Normal Mode	17	Better ↕
1	1	Normal Mode	13.5	
1	0	Normal Mode	8	Best
0	1	Through Mode	—	—

(3) CR2 (Receive side level control)

	B7	B6	B5	B4	B3	B2	B1	B0
CR2	—	—	RPAD6	RPAD5	RPAD4	RPAD3	RPAD2	RPAD1
Initial Value	0	0	0	0	0	0	0	0

B7, B6 Reserved bit. Modification of initial values is inhibited.

B5, B4, B3, B2, B1, B0 Receive side level setting (RPAD)

These bits adjust the receive signal gain and set the mute level. Notice that only the mute level setting differs from pin control. Because data is read by these bits in synchronization with the rising edge of the SYNC signal, hold the data in these bits for 250 μ s or longer.

When using this register, set the TPAD, 3, 2, 1 pins to a logic "0".

(0, 0, 1, 0, 1, 0):	30 dB
(0, 0, 1, 0, 0, 1):	27 dB
(0, 0, 1, 0, 0, 0):	24 dB
(0, 0, 0, 1, 1, 1):	21 dB
(0, 0, 0, 1, 1, 0):	18 dB
(0, 0, 0, 1, 0, 1):	15 dB
(0, 0, 0, 1, 0, 0):	12 dB
(0, 0, 0, 0, 1, 1):	9 dB
(0, 0, 0, 0, 1, 0):	6 dB
(0, 0, 0, 0, 0, 1):	3 dB
(0, 0, 0, 0, 0, 0):	0 dB
(1, 1, 1, 1, 1, 1):	-3 dB
(1, 1, 1, 1, 1, 0):	-6 dB
(1, 1, 1, 1, 0, 1):	-9 dB
(1, 1, 1, 1, 0, 0):	-12 dB
(1, 1, 1, 0, 1, 1):	-15 dB
(1, 1, 1, 0, 1, 0):	-18 dB
(1, 1, 1, 0, 0, 1):	-21 dB
(1, 1, 1, 0, 0, 0):	-24 dB
(1, 1, 0, 1, 1, 1):	-27 dB
(1, 1, 0, 1, 1, 0):	-30 dB
(1, 1, 0, 1, 0, 1):	-33 dB
(1, 1, 0, 1, 0, 0):	-36 dB
(1, 1, 0, 0, 1, 1):	-39 dB
(1, 1, 0, 0, 1, 0):	-42 dB
(1, 1, 0, 0, 0, 1):	-45 dB
(1, 1, 0, 0, 0, 0):	-48 dB
(1, 0, 1, 1, 1, 1):	-51 dB
(1, 0, 1, 1, 1, 0):	-54 dB
(1, 0, 1, 1, 0, 1):	-57 dB
(1, 0, 1, 1, 0, 0):	-60 dB
(1, 0, 1, 0, 1, 1):	MUTE

(4) CR3 (Transmit Gain Adjustment)

	B7	B6	B5	B4	B3	B2	B1	B0
CR3	—	—	TPAD6	TPAD5	TPAD4	TPAD3	TPAD2	TPAD1
Initial Value	0	0	0	0	0	0	0	0

B7, B6 Reserved bits. Modification of initial values is inhibited.

B5, B4, B3, B2, B1, B0 Transmit side level setting (TPAD)

These bits adjust the transmit signal gain and set the mute level. Notice that only the mute level setting differs from pin control. Because data is read by these bits in synchronization with the rising edge of the SYNC signal, hold the data in these bits for 250 μ s or longer.

When using this register, set the TPAD4, 3, 2, 1 pins to a logic "0".

(0, 0, 1, 0, 1, 0):	30 dB
(0, 0, 1, 0, 0, 1):	27 dB
(0, 0, 1, 0, 0, 0):	24 dB
(0, 0, 0, 1, 1, 1):	21 dB
(0, 0, 0, 1, 1, 0):	18 dB
(0, 0, 0, 1, 0, 1):	15 dB
(0, 0, 0, 1, 0, 0):	12 dB
(0, 0, 0, 0, 1, 1):	9 dB
(0, 0, 0, 0, 1, 0):	6 dB
(0, 0, 0, 0, 0, 1):	3 dB
(0, 0, 0, 0, 0, 0):	0 dB
(1, 1, 1, 1, 1, 1):	-3 dB
(1, 1, 1, 1, 1, 0):	-6 dB
(1, 1, 1, 1, 0, 1):	-9 dB
(1, 1, 1, 1, 0, 0):	-12 dB
(1, 1, 1, 0, 1, 1):	-15 dB
(1, 1, 1, 0, 1, 0):	-18 dB
(1, 1, 1, 0, 0, 1):	-21 dB
(1, 1, 1, 0, 0, 0):	-24 dB
(1, 1, 0, 1, 1, 1):	-27 dB
(1, 1, 0, 1, 1, 0):	-30 dB
(1, 1, 0, 1, 0, 1):	-33 dB
(1, 1, 0, 1, 0, 0):	-36 dB
(1, 1, 0, 0, 1, 1):	-39 dB
(1, 1, 0, 0, 1, 0):	-42 dB
(1, 1, 0, 0, 0, 1):	-45 dB
(1, 1, 0, 0, 0, 0):	-48 dB
(1, 0, 1, 1, 1, 1):	-51 dB
(1, 0, 1, 1, 1, 0):	-54 dB
(1, 0, 1, 1, 0, 1):	-57 dB
(1, 0, 1, 1, 0, 0):	-60 dB
(1, 0, 1, 0, 1, 1):	MUTE

(5) CR4 (Line echo canceler setting)

	B7	B6	B5	B4	B3	B2	B1	B0
CR4	LTHR	—	LHLD	$\overline{\text{LHD}}$	LCLP	NCPAD1	$\overline{\text{LATT}}$	$\overline{\text{LGC}}$
Initial Value	0	0	0	0	0	0	0	0

- B7** “Through mode” control 1: “through mode” 0: normal mode (echo canceler operation)
This is the “through mode” control bit for the line echo canceler. In the “through mode”, RinL and SinL data is output directly to RoutL and SoutL respectively while each echo coefficient is maintained. In the through mode, the functions of $\overline{\text{LHD}}$, LHLD, $\overline{\text{LATT}}$ and $\overline{\text{LGC}}$ are invalid. Because data is read by this bit in synchronization with the rising edge of the SYNC signal, hold the data in the bit for 250 μ s or longer.
This bit is internally ORed with the LTHR pin.
- B6** Reserved bit. Modification of initial values is inhibited.
- B5** Coefficient update control 1: fixed coefficients 0: updated coefficients
This bit selects whether the adaptive FIR filter (AFR) coefficients for the line echo canceler will be updated. This function is valid when the ATHR pin is in the normal mode.
Because data is read into this bit by synchronization with the rising edge of the SYNC signal, hold the data at the bit for 250 μ s or longer.
- B4** Howling detector control 1: OFF 0: ON
This bit controls the function to detect and cancel the howling that occurs in an acoustic system such as a handsfree communication system. This function is valid when the LTHR pin is in the normal mode.
Because this bit is read in synchronization with the rising edge of the SYNC signal, hold the data in the bit for 250 μ s or longer.
This bit is internally ORed with the $\overline{\text{LHD}}$ pin.
- B3** Center clip control 1: ON 0: OFF
When the SoutL output of the line echo canceler is -57 dBm0 or less, the center clip function forcibly sets it to the minimum positive value. This function is valid when the LTHR pin is in the normal mode.
Because this bit is read in synchronization with the rising edge of the SYNC signal, hold the data in the bit for 250 μ s or longer.
- B2** NCPAD control
This bit adjusts the noise canceler I/O gain. The gain adjustment is valid for tone control after canceling the noise. The bigger the input level of the noise canceler is, the better the sound quality is. Because this bit is read in synchronization with the rising edge of the SYNC signal, hold the data in the bit for 250 μ s or longer. This bit is internally ORed with the NCPAD1 pin. (Refer to the NCPAD2 pin of CR5-B2.)

NCPAD2	NCPAD1	GPADNC (dB)	LPADNC (dB)
0	0	0	0
0	1	6	-6
1	0	12	-12
1	1	18	-18

- B1** Attenuator control 1: ATT OFF 0: ATT ON
- This bit turns ON or OFF the ATT function to prevent howling by means of attenuators (ATTsL, ATTrL) provided in the RinL input and SoutL output of the line echo canceler.
- If input is only to RinL, the ATT for SoutL (ATTsL) is activated. If input is only to SinL, or if there is input to both SinL and RinL, the ATT for RinL input (ATTrL) is activated. The ATT value of each attenuator is approximately 6 dB. This function is valid when the LTHR pin is in the normal mode. Because this bit is read in synchronization with the rising edge of the SYNC signal, hold the data in the bit for 250 μ s or longer.
- This bit is internally ORed with the $\overline{\text{LATT}}$ pin.
- B0** Gain controller 1: GC OFF 0: GC ON
- This bit turns ON or OFF the gain control function to control the RinL input level and prevent howling by means of a gain controller (GainL) provided in the RinL input of the line echo canceler.
- The gain controller adjusts the RIN input level when it is -10 dBm0 or above, and it has the control range of 0 to -8.5 dB. This function is valid when the LTHR pin is in the normal mode. Because this bit is read in synchronization with the rising edge of the SYNC signal, hold the data in the bit for 250 μ s or longer.
- This bit is internally ORed with the $\overline{\text{LGC}}$ pin.

(6) CR5 (Acoustic echo canceler setting)

	B7	B6	B5	B4	B3	B2	B1	B0
CR5	ATHR	—	AHLD	$\overline{\text{AHD}}$	ACL P	NCPAD2	$\overline{\text{AATT}}$	$\overline{\text{AGC}}$
Initial Value	0	0	0	0	0	0	0	0

- B7** “Through mode” control 1: “through mode” 0: normal mode (echo canceler operation)
 This is the “Through mode” control bit for the acoustic echo canceler. In the “through mode”, RinA and SinA data is output directly to RoutA and SoutA respectively while each echo coefficient is maintained. In the through mode, the functions of $\overline{\text{AHD}}$, AHLD, $\overline{\text{AATT}}$ and $\overline{\text{AGC}}$ are invalid. Because this bit is read in synchronization with the rising edge of the SYNC signal, hold the data in the bit for 250 μs or longer.
 This bit is internally ORed with the ATHR pin.
- B6** Reserved bit. Modification of initial values is inhibited.
- B5** Coefficient update control 1: fixed coefficients 0: updated coefficients
 This bit selects whether the adaptive FIR filter (AFR) coefficients for the acoustic echo canceler will be updated. This function is valid when the ATHR pin is in the normal mode.
 Because this bit is read in synchronization with the rising edge of the SYNC signal, hold the data in the bit for 250 μs or longer.
- B4** Howling detector control 1: OFF 0: ON
 This bit controls the function to detect and cancel the howling that occurs in an acoustic system such as a handsfree communication system. This function is valid when the ATHR pin is in the normal mode.
 Because this bit is read in synchronization with the rising edge of the SYNC signal, hold the data in the bit for 250 μs or longer.
 This bit is internally ORed with the $\overline{\text{AHD}}$ pin.
- B3** Center clip control 1: ON 0: OFF
 When the SoutA output of the acoustic echo canceler is -57 dBm or less, the center clip function forcibly sets it to the minimum positive value. This function is valid when the ATHR pin is in the normal mode.
 Because this bit is read in synchronization with the rising edge of the SYNC signal, hold the data in the bit for 250 μs or longer.
- B2** NCPAD control
 This bit adjusts the noise canceler I/O gain. The gain adjustment is valid for tone control after canceling the noise. The bigger the input level of the noise canceler is, the better the sound quality is. Because this bit is read in synchronization with the rising edge of the SYNC signal, hold the data in the bit for 250 μs or longer. This bit is internally ORed with the NCPAD2 pin. (Refer to the NCPAD1 pin of CR4-B2.)

NCPAD2	NCPAD1	GPADNC (dB)	LPADNC (dB)
0	0	0	0
0	1	6	-6
1	0	12	-12
1	1	18	-18

- B1** Attenuator control 1: ATT 12 dB 0: ATT 6 dB
 This bit selects the attenuation of the ATT function to prevent howling by means of attenuators (ATTsA, ATTrA) provided in the RinA input and SoutA output of the acoustic echo canceler.
 If input is only to RinA, the ATT for SoutA (ATTsA) is activated. If input is only to SinA, or if there is input to both SinA and RinA, the ATT for RinA input (ATTrA) is activated. The ATT value of each attenuator is approximately 6 dB or 12 dB. This function is valid when the ATHR pin is in the normal mode. Because this bit is read in synchronization with the rising edge of the SYNC signal, hold the data in the bit for 250 μ s or longer.
 This bit is internally ORed with the $\overline{\text{AATT}}$ pin.
- B0** Gain controller control 1: GC OFF 0: GC ON
 This bit turns ON or OFF the gain control function to control the RinA input level and prevent howling by means of a gain controller (GainA) provided in the RinA input of the acoustic echo canceler.
 The gain controller adjusts the RIN input level when it is -10 dBm0 or above, and it has the control range of 0 to -8.5 dB. This function is valid when the ATHR pin is in the normal mode. Because this bit is read in synchronization with the rising edge of the SYNC signal, hold the data in the bit for 250 μ s or longer.
 This bit is internally ORed with the $\overline{\text{AGC}}$ pin.

(7) CR6 (Internal data memory write register)

	B7	B6	B5	B4	B3	B2	B1	B0
CR6	A15	A14	A13	A12	A11	A10	A9	A8
Initial Value	0	0	0	0	0	0	0	0

B7 to B0 Memory upper address control

This register sets the upper address of memory. For the writing method, refer to the Method of Internal Data Memory Access section.

(8) CR7 (Internal data memory write register)

	B7	B6	B5	B4	B3	B2	B1	B0
CR7	A7	A6	A5	A4	A3	A2	A1	A0
Initial Value	0	0	0	0	0	0	0	0

B7 to B0 Memory lower address control

This register sets the lower address of memory. For the writing method, refer to the Method of Internal Data Memory Access section.

(9) CR8 (Internal data memory write register)

	B7	B6	B5	B4	B3	B2	B1	B0
CR8	D15	D14	D13	D12	D11	D10	D9	D8
Initial Value	0	0	0	0	0	0	0	0

B7 to B0 Memory upper data control

This register sets the memory's upper data. For the writing method, refer to the Method of Internal Data Memory Access section.

(10) CR9 (Internal data memory write register)

	B7	B6	B5	B4	B3	B2	B1	B0
CR9	D7	D6	D5	D4	D3	D2	D1	D0
Initial Value	0	0	0	0	0	0	0	0

B7 to B0 Memory lower data control

This register sets the memory's lower data. For the writing method, refer to the Method of Internal Data Memory Access section.

(11) CR10 (Echo canceler I/O level setting)

	B7	B6	B5	B4	B3	B2	B1	B0
CR10	GPADA2	GPADA1	LPADA2	LPADA1	GPADL2	GPADL1	LPADL2	LPADL1
Initial Value	0	0	0	0	0	0	0	0

B7, 6 Acoustic output level control

These bits control the PAD level of the gain of the acoustic echo canceler's SoutA output. PAD is turned ON or OFF by either the $\overline{\text{GLPADTHR}}$ pin or the $\overline{\text{GLPADTHR}}$ control register bit (CR1-B2). It is recommended to set the level to the positive level equal to LPADA2 and LPADA1. If the pin setting is changed, the coefficient reset must be activated by either the $\overline{\text{RST}}$ pin or the RST bit (CR0-B6). Because these bits are read in synchronization with the rising edge of the SYNC signal, hold the data in these bits for 250 μs or longer.

(0, 1):	+ 18 dB
(0, 0):	+ 12 dB
(1, 1):	+ 6 dB
(1, 0):	0 dB

B5, 4 Acoustic input level control

These bits control the PAD level of the loss of the acoustic echo canceler's SinA input. PAD is turned ON or OFF by either the $\overline{\text{GLPADTHR}}$ pin or the $\overline{\text{GLPADTHR}}$ control register bit (CR1-B2). Set the level so that echo return loss (value of returned echo) will be attenuated. If the pin setting is changed, the coefficient reset must be activated by either the $\overline{\text{RST}}$ pin or the RST bit (CR0-B6). Because these bits are read in synchronization with the rising edge of the SYNC signal, hold the data in these bits for 250 μs or longer.

(0, 1):	- 18 dB
(0, 0):	- 12 dB
(1, 1):	- 6 dB
(1, 0):	0 dB

B3, 2 Line output level control

These bits control the PAD level of the loss of the line echo canceler's SoutL output. PAD is turned ON or OFF by either the $\overline{\text{GLPADTHR}}$ pin or the $\overline{\text{GLPADTHR}}$ control register bit (CR1-B2). It is recommended to set the level to the positive level equal to LPADL2 and LPADL1. If the pin setting is changed, the coefficient reset must be activated by either the $\overline{\text{RST}}$ pin or the RST bit (CR0-B6). Because these bits are read in synchronization with the rising edge of the SYNC signal, hold the data in these bits for 250 μs or longer.

(0, 1):	+ 18 dB
(0, 0):	+ 12 dB
(1, 1):	+ 6 dB
(1, 0):	0 dB

B1, 0 Line input level control

These bits control the PAD level of the loss of the line echo canceler's SinL output. PAD is turned ON or OFF by either the $\overline{\text{GLPADTHR}}$ pin or the $\overline{\text{GLPADTHR}}$ control register bit (CR1-B2). Set the level so that echo return loss (value of returned echo) will be attenuated. If the pin setting is changed, the coefficient reset must be activated by either the $\overline{\text{RST}}$ pin or the RST bit (CR0-B6). Because these bits are read in synchronization with the rising edge of the SYNC signal, hold the data in these bits for 250 μs or longer.

(0, 1):	- 18 dB
(0, 0):	- 12 dB
(1, 1):	- 6 dB
(1, 0):	0 dB

(12) CR11 (SYNC power-down control register)

	B7	B6	B5	B4	B3	B2	B1	B0
CR11	READY	—	—	—	—	—	PCMSEL	SYPDN
Initial Value	0	0	0	0	0	0	0	0

B7 Data write flag 1: write enabled 0: write disabled
 After power-down reset is released, this device enters the initial mode.
 This bit becomes “1” only during the initial mode, enabling access to the internal data memory.
 Checking this bit will detect whether writing by an external microcomputer is possible.

B6 to B2 Reserved bits. Modification of initial values is inhibited.

B1 PCM coding format control 1: μ -law PCM 0: 16-bit linear
 This is the coding format selection bit for digital data communication. A logic “1” selects μ -law PCM and a logic “0” selects 16-bit linear (2’s complement) coding format. Note that the BCLK output frequency in an internal clock mode does not depend upon this bit but is as per the PCMSEL pin.
 If the digital interface is not used, set this bit to logic “0” to select 16-bit linear coding format. Since this bit is ORed with the PCMSEL pin except for the BCLK frequency decision, set this bit to logic “0” when controlling by the pin. This bit can only be set to “0” or “1” during power-down reset and initial mode.

B0 SYNC-PDWN control 1: PDN/RST power-down 0: PDWN power-down
 This bit controls the function that automatically enters the power-down state when the SYNC signal is fixed to a logic “1” or “0”. This function is valid when the external clock mode has been selected by the CLKSEL pin. Two kinds of power-down modes can be selected.

- PDN/RST power-down mode
 If the SYNC signal is fixed at 8 kHz or longer, this device automatically writes a logic 1 to the control register PDN/RST bit (CR0-B7) and enters the power-down reset state. To return to the normal operation, reset must be activated by either the $\overline{\text{PDN/RST}}$ pin or the PDN/RST bit (CR0-7).
 The state after returning to the normal operation is the same as that reset after power-on.
- PDWN power-down mode
 If the SYNC signal is fixed at 8 kHz or longer, this device automatically enters the power-down state. During the power-down, the analog output is “0” output (mute) and the SG output holds about 1.4 V. To return to the normal operation, detect the SYNC signal rise. In the state after returning to the normal operation, internal variables and coefficients of the echo canceler and noise canceler are reset. Each bit of the control register is held and operates normally after about 200 ms.

	PDN/RST power-down	PDWN power-down
SYPDN (CR11-B0)	1	0
Internal process	PDN/RST (CR0-B7) = 1	Mute control
Power-down removal method	PDN/RST pin or bit	SYNC rising edge
After removing power-down	–Reset Each bit of CR. Internal coefficient. Echo canceler coefficient. Noise canceler coefficient.	–Reset Internal coefficient. Echo canceler coefficient. Noise canceler coefficient. –Hold Each bit of CR.
Operating Current	Typ. 0.02 mA	TBD

(13) CR12 (Reserved register)

	B7	B6	B5	B4	B3	B2	B1	B0
CR12	—	—	—	—	—	NCSEL2	—	—
Initial Value	0	0	0	0	0	0	0	0

B7 to B3 Reserved bits. Modification of initial values is inhibited.

B2 Noise attenuation selection control

This bit selects the noise attenuation of the noise canceler. In the “through mode”, the noise canceler is halted and data is output directly. In the “normal mode” the noise canceler operates normally. Since the noise attenuation in the normal mode is selected after the initial mode has been released, the change of the noise attenuation during normal operation is invalid. If the noise attenuation is changed, reset must be activated by the $\overline{\text{RDN/RST}}$ pin or the PDN/RST bit (CR0-B7). Changing to the through mode during normal operation and returning to the normal mode are possible. This bit is internally ORed with the NCSEL2. (Refer to the NCSEL1 pin of CR1-B0.)

Note: Since there is a trade-off between noise attenuation and sound quality after canceling the noise, select the noise attenuation appropriate to the sound quality.

NCSEL2	NCSEL1	NC Mode	Attenuation (dB)	Quality
0	0	Normal Mode	17	Better
1	1	Normal Mode	13.5	↓
1	0	Normal Mode	8	Best
0	1	Through Mode	—	—

B1, B0 Reserved bits. Modification of initial value is inhibited.

RELATIONSHIP BETWEEN PINS AND CONTROL REGISTERS

In this device, the same function is controlled by either a pin or a control register.

For example, when a function is controlled by a pin, setting of the corresponding control register is important. Table 3 shows the relationship between settings of pins when functions are controlled by control registers and setting of control registers when functions are controlled by pins. The setting value of a control register when a function is controlled by a pin is equal to its initial value when the device is reset by the $\overline{\text{PDN/RST}}$ pin or the PDN/RST bit (CR0-B7).

Table 3 Relationship between pins and control registers

Function	Setting of pin when function is controlled by control register	Setting of control register when function is controlled by pin
$\overline{\text{LINEEN}}$	Logic "0"	0
$\overline{\text{PDN/RST}}$	Logic "1"	0
PCMSEL	Logic "0"	0
ECSEL	Logic "0"	0
LTHR/ATHR	Logic "0"	0
LHD/AHD	Logic "0"	0
LATT/AATT	Logic "0"	0
LGC/AGC	Logic "0"	0
GLPADTHR	Logic "0"	0
SLPTHR	Logic "0"	0
RST	Logic "1"	0
MCUSEL	Logic "0"	0
RPAD4-1	Logic "0"	0
TPAD4-1	Logic "0"	0
NCSEL1, 2	Logic "0"	0
NCPAD1, 2	Logic "0"	0

CONTROL METHOD BY MCU

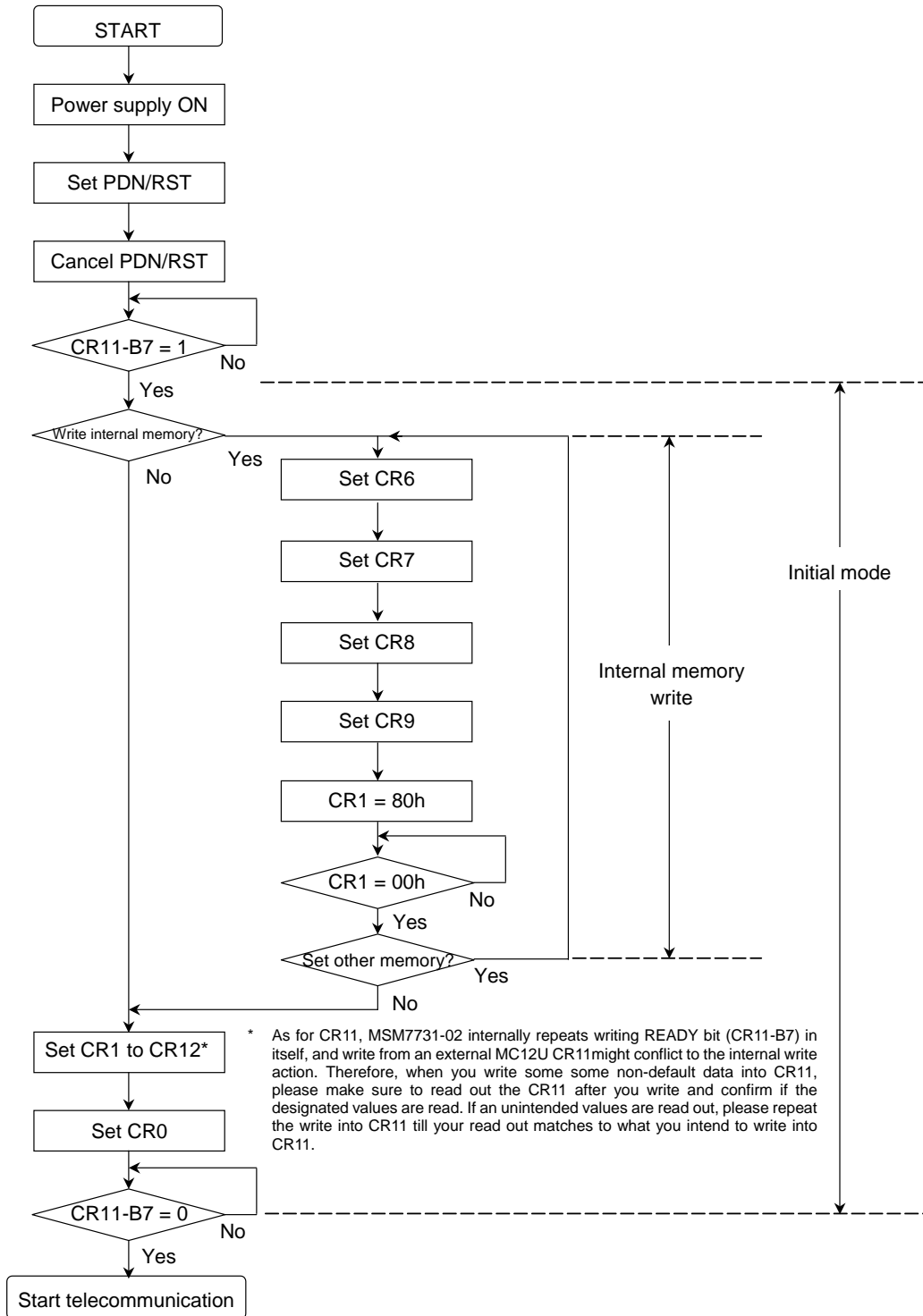

METHOD OF INTERNAL DATA MEMORY ACCESS

The default values such as the cancelable echo delay time, echo attenuation and noise attenuation can be changed during the initial mode (CR0-B1, CR0-B0 = "00").

Refer to the procedure below.

1. Set the address of the default value store memory. (CR6, 7)
2. Set the modified values (data). (CR8, 9)
3. Set the write command. (CR1-B7 = "1")

After the write operation is complete, the write command (CR1-B7) is cleared to "0". Consecutive writes are possible.

(Example) In the case of changing the acoustic delay time in a single echo canceler mode to 30 ms.

Address: 009Bh, Data: 00F0h

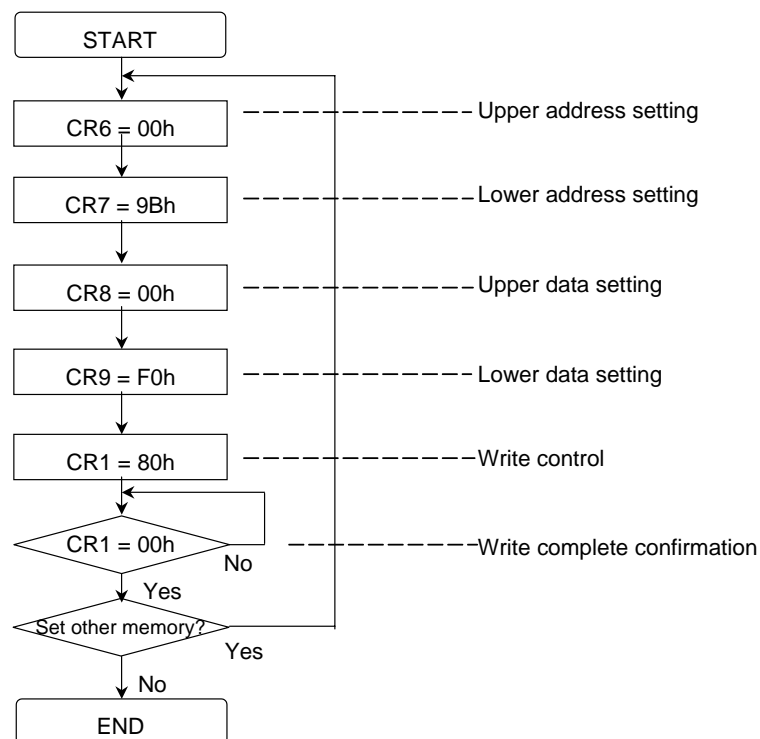

Please note that the MSM7731-02 used in the following setting will shift into PDWN power-down mode when the SYNC and BCLK externally supplied stop. The MSM7731-02 automatically returns to normal operation mode when the SYNC and BCLK resume being supplied, but at the same time the set data memories (internal coefficient) are initialized.

- CLKSEL-pin = digital "1" (external clock mode)
- CR12-B0 (SYPDN bit) = "0"

Echo Canceler Delay Time

Cancelable echo delay time is as follows.

(1) Single echo canceler mode

Acoustic echo canceler

Default : 59 ms

Variable range : 0.5 to 59 ms (in 0.5 ms steps)

Line echo canceler operation is halted.

(2) Dual echo canceler mode (operation of acoustic and line echo cancelers)

Condition : acoustic delay time + line delay time ≤ 59 ms

Acoustic echo canceler

Default : 44 ms

Variable range : 0.5 to 58.5 ms (in 0.5 ms steps)

Line echo canceler

Default : 15 ms

Variable range : 0.5 to 27 ms (in 0.5 ms steps)

Memory addresses are shown below.

(1) Single echo canceler mode

Memory address of acoustic echo canceler delay time : 009Bh

(2) Dual echo canceler mode (operation of acoustic and line echo cancelers)

Memory address of acoustic echo canceler delay time : 0099h

Memory address of line echo canceler delay time : 009Ah

The method for calculating delay time is shown below.

delay time [s] × 8000 = delay time data (HEX)

Example of 30 ms:

$$0.03 \times 8000 = 240 \text{ (DEC)}$$

$$= 00F0 \text{ (HEX)}$$

Echo canceler mode	Echo canceler	Address	Default time	Default data	Changeable range
Dual echo canceler	Acoustic side	0099h	44 ms	0160h	0.5 to 58.5 ms
	Line side	009Ah	15 ms	0078h	0.5 to 27.0 ms
Single echo canceler	Acoustic side	009Bh	59 ms	01D8h	0.5 to 59.0 ms
	Line side	—	—	—	—

Notes : Dual echo canceler mode condition
 Acoustic echo canceler delay time + line echo canceler delay time ≤ 59 ms
 : Setting delay time condition
 0.5 ms steps (increment width)

Noise Attenuation

There is a trade-off between noise attenuation and sound quality. In other words, increasing the noise attenuation deteriorates sound quality, and decreasing the noise attenuation improves sound quality. The following combinations of noise attenuation levels can be selected with this device. Select the noise attenuation appropriate to the sound quality.

When selecting the following combinations by the method of internal data memory access, set the NCSEL1/NCSEL2 pin and bit as follows:

NCSEL1 pin and bit (CR1-B0) = 0

NCSEL2 pin and bit (CR12-B2) = 0

Noise attenuation [dB] address	Data 1	Data 2	Voice quality
	01C8h	01C2h	
17 (default)	2000h	0005h	Better  Best
14	3333h	0005h	
13.5	3333h	0004h	
12	4666h	0005h	
11	4666h	0003h	
10	5999h	0005h	
10	6CCCh	0005h	
9	6666h	0005h	
8	5999h	0002h	
8	2000h	0001h	
8	3333h	0001h	
7	4666h	0001h	
7	5999h	0001h	
6	6666h	0001h	

Attenuation of ATT Function

The attenuation (ATT values) of echo canceler ATT functions (ATTsL/ATTTrL, ATTsA/ATTTrA) can be selected from the following combinations. When selecting the attenuation, take note of the following.

1. Increasing the attenuation causes almost half duplex.
2. Increasing the attenuation causes the sound of the beginning and ending of words to be cut.
3. Increasing the attenuation remarkably changes the sound volume of background noise. (due to On/OFF of the ATTs/ATTTr)

When selecting the following combinations by the method of internal data memory access, set the $\overline{\text{AATT}}$ and the $\overline{\text{LATT}}$ pins and bits as follows:

In a case with the ECSEL pin = 1 or in a case with both the ECSEL pin = 0 and CR0-B1,0 = (1,1)

- The $\overline{\text{AATT}}$ pin and its bit (CR5-B1) = 0; the $\overline{\text{LATT}}$ pin and its bit (CR4-B1) = "Don't care"

In a case with both the ECSEL pin = 0 and CR0-B1,0 = (1,0)

- The $\overline{\text{AATT}}$ pin and its bit (CR5-B1) = 0; the $\overline{\text{LATT}}$ pin and its bit (CR4-B1) = 0

Though it's possible to set different attenuations for ATTsA and ATTTrA and to set different attenuation for ATTsL and ATTTrL, the attenuation by ATTsA and ATTsL and the attenuation by ATTTrA and ATTTrL are always set the same.

ATTTrA ATTTrL attenuation	Data 1	ATTTrA ATTTrL attenuation	Data 1	ATTTrA ATTTrL attenuation	Data 1
Address	0199h	Address	0199h	Address	0199h
0 dB	7FFFh	5 dB	47FAh	10 dB	287Ah
1 dB	7214h	6 dB *	4000h	11 dB	2413h
2 dB	65ACh	7 dB	392Ch	12 dB	2000h
3 dB	5A9Dh	8 dB	32F5h	18 dB	1000h
4 dB	50C3h	9 dB	2D6Ah	24 dB	0800h

* default

ATTsA ATTsL attenuation	Data 2	Data 3	Data 4	Data 5	ATTsA ATTsL attenuation	Data 2	Data 3	Data 4	Data 5
Address	019Ch	019Fh	01A2h	01A5h	Address	019Ch	019Fh	01A2h	01A5h
0 dB	7FFFh	7FFFh	7FFFh	7FFFh	8 dB	4000h	34F5h	34F5h	32F5h
1 dB	7214h	7214h	7214h	7214h	9 dB	4000h	2F6Ah	2F6Ah	2D6Ah
2 dB	65ACh	65ACh	65ACh	65ACh	10 dB	4000h	2A7Ah	2A7Ah	287Ah
3 dB	5A9Dh	5A9Dh	5A9Dh	5A9Dh	11 dB	4000h	2613h	2613h	2413h
4 dB	50C3h	50C3h	50C3h	50C3h	12 dB	4000h	2200h	2200h	2000h
5 dB	47FAh	47FAh	47FAh	47FAh	18 dB	4000h	2000h	1200h	1000h
6 dB*	4200h	4200h	4200h	4000h	24 dB	4000h	2000h	1000h	0800h
7 dB	4000h	3B2Ch	3B2Ch	392Ch					

* default

GAIN ADJUSTMENT OF EXTERNAL SPEAKER AMPLIFIER

The overflow (clipping) of speaker amplifier output occurred in the echo path between the echo canceler output (e.g. AVFRO) and the echo canceler input (e.g. AGSX) decreases the echo attenuation remarkably. In other words, when an external speaker amplifier is used, do gain adjusting without overflow of speaker amplifier output.

Adjusting Method 1

Be careful of the following.

1. Echo canceler output pin (AVFRO/LVFRO)
Adjust the AGSX/LGSX gain or RPAD/TPAD so as to set the output level to less than $1.3 V_{pp}$ (typical level = -20 dBm0).
2. External speaker amplifier output pin
Adjust the gain so as to set the output level to less than the maximum output amplitude.

Adjusting Method 2

The speaker amplifier output can be adjusted appropriately by making the echo canceler input signal clipped intentionally when the speaker amplifier output is small.

1. External speaker amplifier gain

The analog maximum output amplitude of the MSM7731 and the maximum output amplitude of external speaker amplifier determine the speaker amplifier gain.

(Example)

AVFRO maximum output amplitude = $1.3 V_{pp}$

Gain of APWI and AOUI = 1

Maximum output amplitude of external speaker amplifier = $10 V_{pp}$

External speaker amplifier gain

= speaker amplifier maximum output amplitude / AVFRO maximum output amplitude

= $10 / 1.3$

= less than 7.6

2. Speaker output adjustment

Adjust the volume with the echo canceler input (RPAD).

The following shows the circuit diagram.

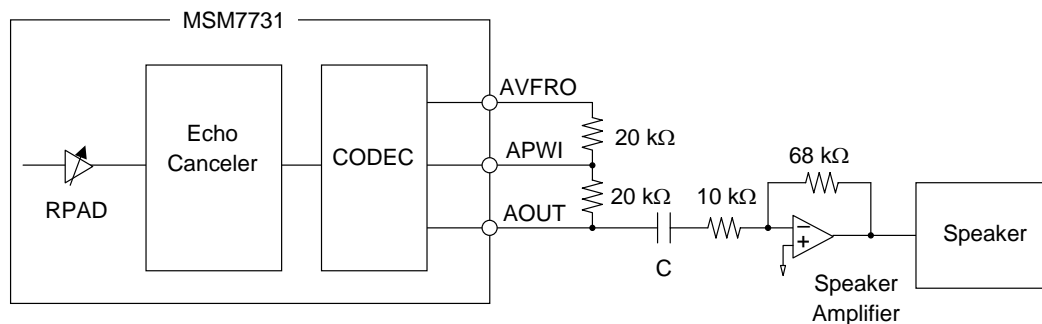

DIFFERENCE BETWEEN MSM7731-01 AND MSM7731-02

Function	Control method	MSM7731-01	MSM7731-02
Noise Attenuation Selection	MCU Control	variable by initial download 17 dB or through selectable by NCTHR bit	variable by initial download 17 dB, 13.5 dB, 8 dB or through selectable by NCSEL1, 2 bits
	Pin Control	17 dB or through selectable by NCTHR pin	17 dB, 13.5 dB, 8 dB or through selectable by NCSEL1, 2 pins
Noise Canceler I/O Gain Adjustment Function	MCU Control	None	±0 dB, ±6 dB, ±12 dB or ±18 dB selectable by NCPAD1, 2 bits
	Pin Control	None	±0 dB, ±6 dB, ±12 dB or ±18 dB selectable by NCPAD1, 2 pins
Acoustic Echo Canceler Attenuator Function	MCU Control	variable by initial download 0 dB or 6 dB selectable by AATT bit	variable by initial download 6 dB or 12 dB selectable by AATT bit
	Pin Control	0 dB or 6 dB selectable by AATT pin	6 dB or 12 dB selectable by AATT pin
Line Acoustic Echo Canceler Coefficient Update Function	MCU Control	ON or OFF selectable by AHLD, LHLD bit	ON or OFF selectable by AHLD, LHLD bits
	Pin Control	ON or OFF selectable by AHLD, LHLD pin	always updated (ON)
SYNC Power-down	MCU Control	Power down function (PDN/RST) ON or OFF selectable by SYPDN bit *1	Power down function (PDN/RST) ON or OFF selectable by SYPDN bit *1
	Pin Control	None	always operated (ON) *1 Power down function (PDWN)

Note*1: Refer to the description of “(12) CR11 (SYNC-PDWN Control Register)” of this data sheet.

1. Pins

(MSM7731-01)		(MSM7731-02)
NCTHR	→	NCSEL1
TEST8	→	NCSEL2
LHLD	→	NCPAD1
AHLD	→	NCPAD2

2. Control registers

	(MSM7731-01)		(MSM7731-02)
CR1-B0	NCTHR	→	NCSEL1
CR12-B2	X	→	NCSEL2
CR4-B2	LHLD	→	NCPAD1
CR5-B2	AHLD	→	NCPAD2
CR4-B5	X	→	LHLD
CR5-B5	X	→	AHLD

3. Functions

Noise attenuation selection	(MSM7731-02) Function added (17, 13.5, 8 dB, THR-selectable)
Noise canceler I/O gain adjustment	Function added (± 0 , ± 6 , ± 12 , ± 18 dB-selectable)
Acoustic echo canceler coefficient update	Pin control disabled
Line echo canceler coefficient update	Pin control disabled
Acoustic echo canceler attenuator	Attenuation changed, OFF function deleted (6, 12 dB selectable)
SYNC power-down	Control changed (PDN/RST power-down, PDWN power-down)

NOTES ON USE

1. Use a stabilized power supply with a low level of noises (especially spike noises and pulse noises of high frequencies) in order to prevent this device from malfunction or degradation in characteristics.
2. Place a good characteristic of bypass-capacitor for the power supply near the pins of this device in order to assure its electrical characteristics.
3. Place a good characteristic of bypass-capacitor for the analog signal ground (SG pin) near the pins of this device in order to assure its electrical characteristics.
4. Connect the AGND, DGND1 and DGND 2 to the system ground at a shortest distance and in a low impedance state.
5. Use a separate power supply for an external speaker amplifier so as not to be disturbed by externally generated noises.
6. When an external speaker amplifier is used, do gain adjusting without overflow (saturation) of speaker amplifier output.
The overflow of speaker amplifier output decreases the echo attenuation.
7. Set the analog signal input level to less than $1.3 V_{PP}$ to prevent overflow.
Otherwise, voice will be distorted.
8. Set the echo return loss (ERL) to be attenuated. If the echo return loss is to be amplified, the GLPAD function should be used.
The ERL refers to echo attenuation (loss) between the echo canceler output (RoutA/RoutL) and the echo canceler input (SinA/SinL).
Refer to Characteristics Diagram for the ERL vs. echo attenuation.
9. The input level should be -10 to -20 dBm0.
Refer to Characteristics Diagram for the ERL vs. echo attenuation.
10. Adjust the volume at the position of the echo canceler input (RinA/RinL).
When in Dual Echo Canceler mode : Adjust the volume with TPAD and RPAD.
When in Signal Echo Canceler mode : Adjust the volume with TPAD and RPAD, or with the analog input (LIN) that is set at less than $1.3 V_{PP}$.
11. 11. When the echo path is changed (when resuming telephone communication), reset the device either with the $\overline{\text{PDN/RST}}$ pin, the PDN/RST bit, the $\overline{\text{RST}}$ pin or the RST bit.
12. After turning on the power, be sure to reset the device with the $\overline{\text{PDN/RST}}$ pin.
13. In order to get the highest performance of this device, the following functions should be used.

$\overline{\text{AATT/LATT}}$: ON
$\overline{\text{AGC/LGC}}$: ON
SLPTHR	: Normal mode (slope filter operation)
NCTHR	: Normal mode (noise canceler operation)
RPAD6-1	: Adjusting the volume of receive signal
TPAD6-1	: Adjusting the volume of transmit signal

APPLICATION CIRCUIT (1)

In case of line analog interface and pin control
 (NCSEL = 13.5 dB, NCPAD = ±6 dB, TRAD = 9 dB)

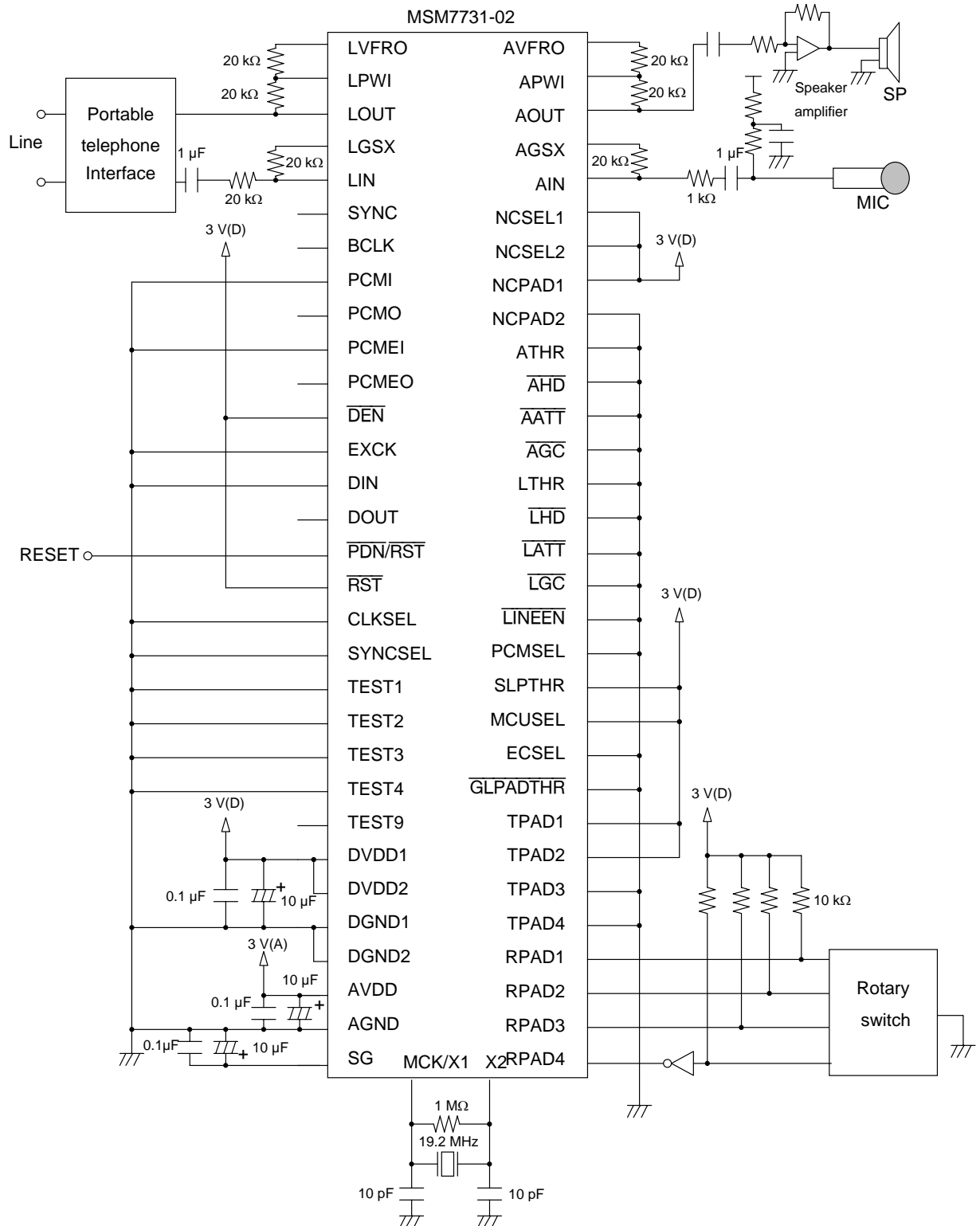

APPLICATION CIRCUIT (2)

In case of line digital interface and MCU control

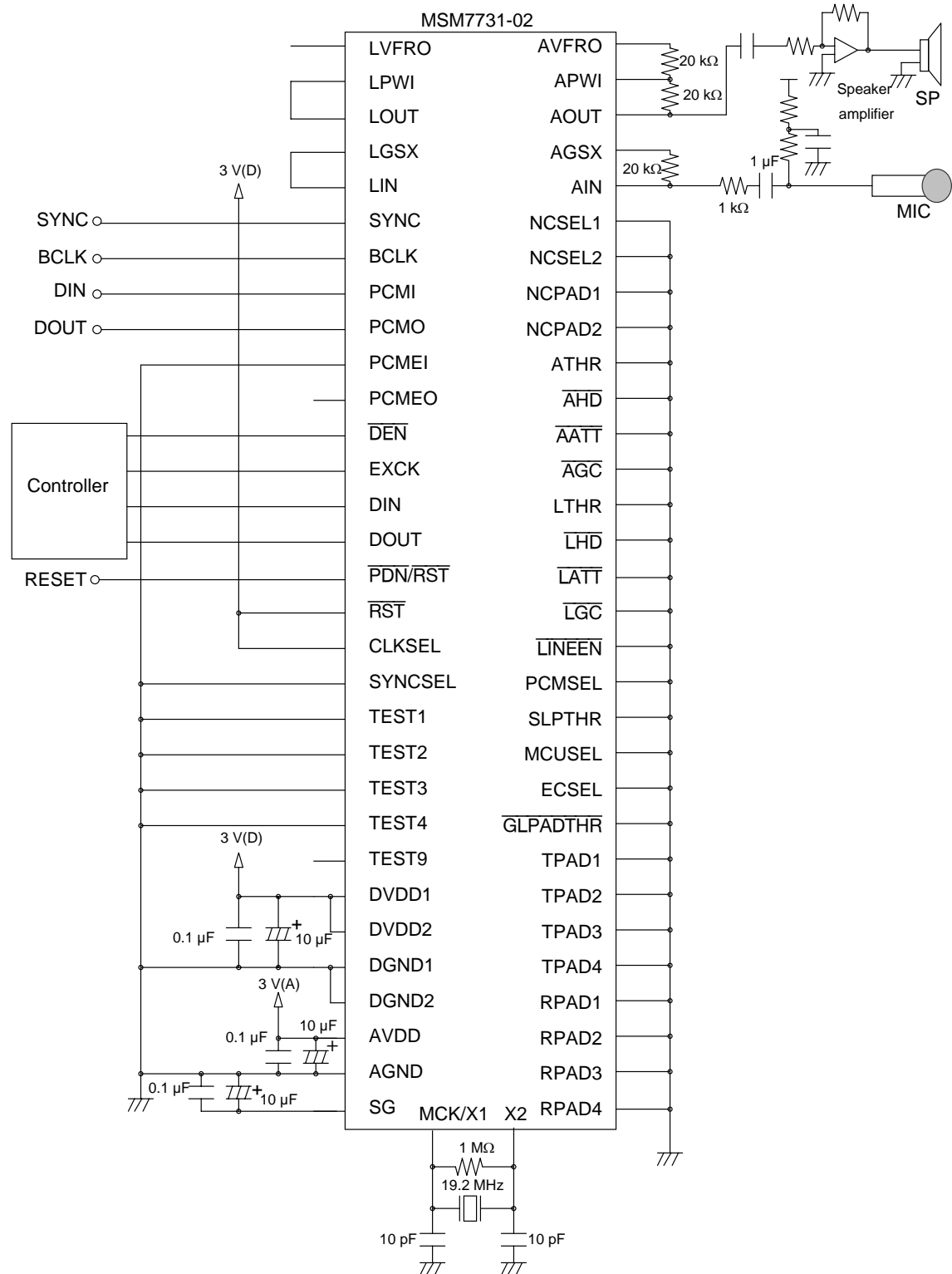

PACKAGE DIMENSIONS

(Unit : mm)

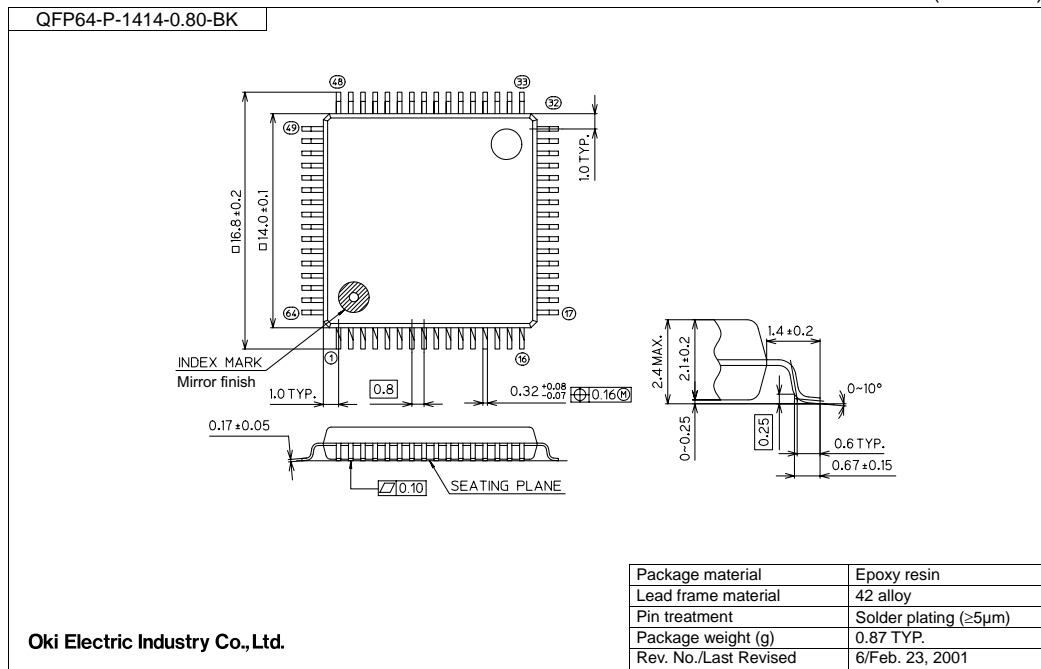

Note: A lead-free package is available. Please contact Oki Sales Office/Distributors for more information.

Notes for Mounting the Surface Mount Type Package

The surface mount type packages are very susceptible to heat in reflow mounting and humidity absorbed in storage.

Therefore, before you perform reflow mounting, contact Oki's responsible sales person for the product name, package name, pin number, package code, and desired mounting conditions (reflow method, temperature and times).

REVISION HISTORY

Document No.	Date	Page		Description
		Previous Edition	Current Edition	
FEDL7731-02-04	Jan. 2000	–	–	Edition 4
FEDL7731-02-05	Jan. 29, 2002	2	2	Typo corrections of "center clip"
		14	14	Correction in conditions columns for F_{BCK} , D_{CK} , f_{SYNC} , t_{WS}
		41	41	Addition of remarks on CR11 data write
		49	49	Correction of description with #12
		50	–	Removal of Application Circuit
		–	52	Addition of Revision History
FEDL7731-02-06	Feb. 26, 2002	15	15	Relax of the minimum specification of High Level Digital Output Voltage (V_{OH}) under DC Characteristics
		44	45	Expansion of options for ATT values
FEDL7731-02-07	Aug. 15, 2002	45	45	Correction of Data2/3/4/5 for 5dB setting with ATTsA/ATTsL
FEDL7731-02-08	Oct. 7, 2002	44	44	Addition of another data combination for 10dB noise attenuation
FEDL7731-02-09	Dec 6, 2002	5	5	Deletion of CX-91F as an example of crystal possible to use as the C and the R values are not confirmed.
		6	6	Correction of conditions to determine BCLK output frequency in internal clock mode under the BCLK pin description.
		7	7	Addition of output BCLK frequency decisive condition under the PCMSEL pin description.
		15, 16, 17, 18	15, 16, 17, 18	Correction of a typo with T_a as a thermal condition for electrical characteristics ("–25 to +85°C" to "–40 to +85°C")
		38	38	Correction of condition to determine BCLK output frequency in internal clock mode and paraphrase of notes for bit setting alternation under the PCMSEL bit.
		42	42	Addition of a note to remind that internal data memories set via CR6 – 9 are initialized at a return to normal operation from PDWN power-down mode when external clock mode
FEDL7731-02-10	Apr 7, 2003	14	14	Addition of "Analog" for input and output absolute maximum ratings
FEDL7731-02-11	Sep 2, 2003	49	49	Addition of PDN/RST to Item#11

NOTICE

1. The information contained herein can change without notice owing to product and/or technical improvements. Before using the product, please make sure that the information being referred to is up-to-date.
2. The outline of action and examples for application circuits described herein have been chosen as an explanation for the standard action and performance of the product. When planning to use the product, please ensure that the external conditions are reflected in the actual circuit, assembly, and program designs.
3. When designing your product, please use our product below the specified maximum ratings and within the specified operating ranges including, but not limited to, operating voltage, power dissipation, and operating temperature.
4. Oki assumes no responsibility or liability whatsoever for any failure or unusual or unexpected operation resulting from misuse, neglect, improper installation, repair, alteration or accident, improper handling, or unusual physical or electrical stress including, but not limited to, exposure to parameters beyond the specified maximum ratings or operation outside the specified operating range.
5. Neither indemnity against nor license of a third party's industrial and intellectual property right, etc. is granted by us in connection with the use of the product and/or the information and drawings contained herein. No responsibility is assumed by us for any infringement of a third party's right which may result from the use thereof.
6. The products listed in this document are intended for use in general electronics equipment for commercial applications (e.g., office automation, communication equipment, measurement equipment, consumer electronics, etc.). These products are not, unless specifically authorized by Oki, authorized for use in any system or application that requires special or enhanced quality and reliability characteristics nor in any system or application where the failure of such system or application may result in the loss or damage of property, or death or injury to humans.
Such applications include, but are not limited to, traffic and automotive equipment, safety devices, aerospace equipment, nuclear power control, medical equipment, and life-support systems.
7. Certain products in this document may need government approval before they can be exported to particular countries. The purchaser assumes the responsibility of determining the legality of export of these products and will take appropriate and necessary steps at their own expense for these.
8. No part of the contents contained herein may be reprinted or reproduced without our prior permission.

Copyright 2003 Oki Electric Industry Co., Ltd.