

FEDL7051LA-02

**OKI Semiconductor**

This version: Sept. 2000

**ML7051LA****Bluetooth Baseband Controller IC****GENERAL DESCRIPTION**

The ML7051LA is a CMOS digital IC for use in 2.4 GHz band Bluetooth systems. This IC incorporates the ARM7TDMI as the CPU core, features a highly expandable architecture, and supports the interfaces for a variety of applications. Used in conjunction with the ML7050LA (Bluetooth RF Transceiver IC) and the OKI Bluetooth Protocol Stack Software, data/voice communications are possible while maintaining interconnectivity with other Bluetooth systems.

**FEATURES**

- Conforms to the Bluetooth Specification (Ver1.0B)
- The ARM7TDMI is installed as the CPU (operation at a maximum of 32 MHz in this LSI)
- 1-Ch, 16-bit auto-reload timer
- Interrupt controller (17 causes)
- Built-in 8 kbyte, 4-Way Copy Back Unified Cache
- Built-in 24 kbyte RAM (supports 16-byte burst access)
- Up to a total of 2 Mbyte of SRAM, ROM, and Flash ROM can be connected to the external memory bus.
- PCM-CVSD transcoder is installed.
- Installed interfaces:
  - UART<sup>(\*)</sup> interface (up to 921.6 kbps)
  - USB<sup>(\*)</sup> interface (conforms to USB1.1)
  - UART synchronous serial port interface
  - General-purpose I/O interface (programmable interrupts)
  - PCM interface (PCMLinear/A-law/ $\mu$ -law can be selected)
  - JTAG interface
- <sup>(\*)</sup> This mark indicates interfaces that support the HCI command.
- Power supply voltages: For I/O: 3.0 to 3.6 V; for internal core: 2.25 to 2.75 V
- Package: 144-pin BGA (P-LFBGA144-1111-0.80)  
(Dimensions: 11 mm × 11 mm × 1.5 mm; pin pitch: 0.8 mm)



ARM and the ARM POWERED logo are registered trademarks of ARM Ltd., UK.

ARM7TDMI and Thumb are trademarks of ARM Ltd., UK.

The information contained herein can change without notice owing to the product being under development.

**ABSOLUTE MAXIMUM RATINGS**

Parameter	Symbol	Conditions	Rating	Unit
Power supply voltage	$V_{DD}$	—	-0.3 to +4.5	V
Input voltage	$V_I$	—	-0.3 to +4.5	V
Allowable power dissipation	$P_d$	—	1.35	W
Storage temperature	$T_{stg}$	—	-55 to 150	°C

**RECOMMENDED OPERATING CONDITIONS**

Parameter	Symbol	Conditions	Min.	Typ.	Max.	Unit
Power supply voltage (for I/O)	$V_{dd\_io}$	—	3.0	3.3	3.6	V
Power supply voltage (for the internal core)	$V_{dd\_core}$	—	2.25	2.5	2.75	V
"H" level input voltage	$V_{ih}$	—	2.2	—	3.6	V
"L" level input voltage	$V_{il}$	—	0	—	0.8	V
Operating temperature	$T_a$	—	-40	—	85	°C

**ELECTRICAL CHARACTERISTICS****DC Characteristics**(V<sub>dd\_io</sub> = 3.3 V ±0.3V, V<sub>dd\_core</sub> = 2.5 V ±10%, T<sub>a</sub> = 0 to 70°C)

Parameter	Symbol	Conditions	Min.	Typ.	Max.	Unit
"H" level output voltage	$V_{oh}$	$I_{oh} = -4$ mA	2.4	—	—	V
"L" level output voltage	$V_{ol}$	$I_{ol} = 4$ mA	—	—	0.4	V
Input leak current	$I_i$	$V_i =$ GND to 3.6 V	-10	—	10	μA
Output leak current	$I_o$	$V_o =$ GND to V <sub>dd</sub>	-10	—	10	μA
Power supply current (during operation)	$I_{ddo}$	During 32 MHz operation	0	50	70	mA
Power supply current (during stand-by)	$I_{dds}$	CLK Stopped	—	50	500	μA

**PIN PLACEMENT**

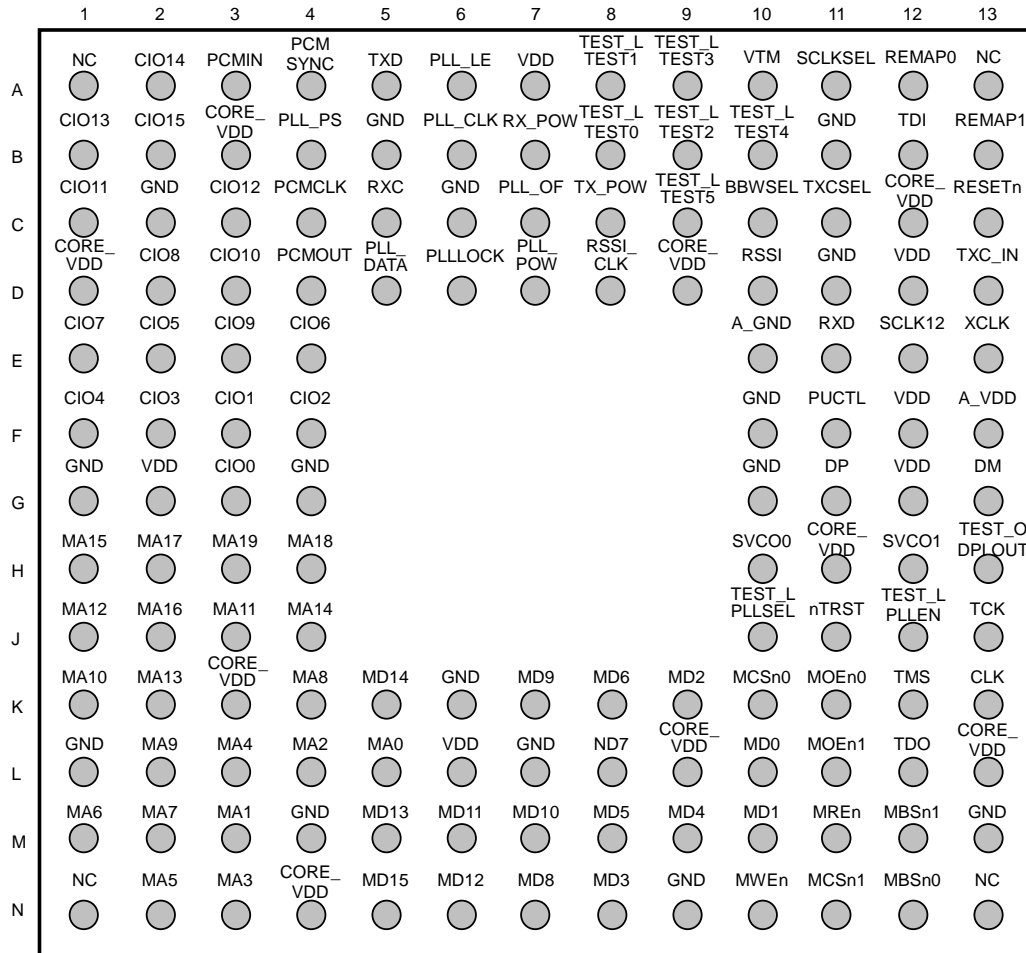

**TOP VIEW**

**PIN DESCRIPTIONS****RF I/F**

Pin Name	I/O	Internal Pull Up/Down	Initial Value	Pin Placement	Description
TXD	O	—	—	A5	Transmit data output (To ML7050LA Pin# A8)
RXD	I	—	—	E11	Receive data input (To ML7050LA Pin# H5)
PLL_DATA	O	—	L	D5	PLL setting data output (To ML7050LA Pin# H3)
PLL_CLK	O	—	L	B6	PLL setting clock output (To ML7050LA Pin# G3)
PLL_LE	O	—	L	A6	PLL setting load enable output (To ML7050LA Pin# H4)
PLL_OFF	O	—	L	C7	PLL Open-loop/Closed-loop control signal output (To ML7050LA Pin# G8)
RSSI	I	Pull down	—	D10	Receive field strength data input (To ML7050LA Pin# G6)
RSSI_CLK	O	—	—	D8	RSSI transfer clock (To ML7050LA Pin# H8)
PLL_POW	O	—	H	D7	Local transmit circuit power control signal output (To ML7050LA Pin# A7)
TX_POW	O	—	H	C8	Transmit power control signal output (To ML7050LA Pin# B6)
RX_POW	O	—	H	B7	Receive power control signal output (To ML7050LA Pin# B3)
PLL_PS	O	—	L	B4	PLL power control signal output
PLLLOCK	I	Pull down	L	D6	PLL lock signal input
RXC	O	—	L	C5	Bluetooth receive clock output (1 MHz)
TXC_IN	I	Pull down	L	D13	Bluetooth transmit clock input (1 MHz) When the transmit clock is used by a clock (RXC) that is generated from the receive data, set TXCSEL(Pin# C11) to H and connect to RXC(Pin# C5).
TXCSEL	I	Pull down	L	C11	Bluetooth transmit clock setting pin L: Select 1 MHz divided by internal PLL. H: Select TXC_IN input signal.

**CLK and Configuration**

Pin Name	I/O	Internal Pull Up/Down	Initial Value	Pin Placement	Description
SCLK12	I	—	—	E12	Master clock (12 MHz) input pin (Power level: CMOS level)
XCLK	I	—	—	E13	User clock input pin
SCLKSEL	I	Pull down	—	A11	System clock select pin L: Select CLK divided by internal PLL H: Select XCLK input signal
RESETn	I	—	—	C13	Hardware reset pin (Reset = L)
BBWSEL	I	—	—	C10	BANK0 region bit width select pin L: 8-bit H: 16-bit
REMAP0	I	—	—	A12	REMAP select pin during boot up
REMAP1	I			B13	REMAP[1:0] = "00" Reserved "01" Stacked Flash ROM "10" External MCS[1] device "11" External MCS[0] device

**Memory I/F**

Pin Name	I/O	Internal Pull Up/Down	Initial Value	Pin Placement	Description
MA[19:0]	O	—	L	[*1]	External address bus
MD[15:0]	I/O	—	Z	[*2]	External data bus
MWEn	O	—	H	N10	External write enable signal output
MREn	O	—	H	M11	External read enable signal output
MCSn0	O	—	H	K10	External RAM space chip select
MCSn1	O	—	H	N11	External I/O space chip select
MBSn0	O	—	H	N12	External lower byte select
MBSn1	O	—	H	M12	External upper byte select
MOEn0	O	—	H	K11	External MCS[0] device output enable (MCSn0 and WREn OR output)
MOEn1	O	—	H	L11	External MCS[1] device output enable (MCSn1 and WREn OR output)
MWAIT	I	—	—	F3	External wait signal input (Pin shared with GPIO1)

[\*1] MA19: H3; MA18: H4; MA17: H2; MA16: J2; MA15: H1; MA14: J4  
 MA13: K2; MA12: J1; MA11: J3; MA10: K1; MA9: L2; MA8: K4; MA7: M2  
 MA6: M1; MA5: N2; MA4: L3; MA3: N3; MA2: L4; MA1: M3; MA0: L5

[\*2] MD15: N5; MD14: K5; MD13: M5; MD12: N6; MD11: M6; MD10: M7  
 MD9: K7; MD8: N7; MD7: L8; MD6: K8; MD5: M8; MD4: M9; MD3: N8;  
 MD2: K9; MD1: M10; MD0: L10

**USB I/F**

Pin Name	I/O	Internal Pull Up/Down	Initial Value	Pin Placement	Description
DP	I/O	—	Z	G11	USB data
DM	I/O	—	Z	G13	USB data
PUCTL	O	—	L	F11	Pull-up control pin
VBUS (GPIO0)	I	—	—	G3	USB detection pin

**UART I/F**

Pin Name	I/O	Internal Pull Up/Down	Initial Value	Pin Placement	Description
SOUT	O	—	H	B2	ACE transmit serial data (Pin shared with GPIO15)
SIN	I	—	—	A2	ACE receive serial data (Pin shared with GPIO14)
DCD	I	—	—	B1	Data carrier detection (Pin shared with GPIO13)
RTS	O	—	H	C3	ACE transmit data ready (Pin shared with GPIO12)
CTS	I	—	—	C1	ACE transmit ready (Pin shared with GPIO11)
DSR	I	—	—	D3	Receive data ready (Pin shared with GPIO10)
DTR	O	—	H	E3	Receive ready (Pin shared with GPIO9)
RI	I	—	—	D2	Ring indicator (Pin shared with GPIO8)

**SIO I/F**

Pin Name	I/O	Internal Pull Up/Down	Initial Value	Pin Placement	Description
STXD	O	—	H	E1	Serial data output (Pin shared with GPIO7)
SRXD	I	—	—	E4	Serial data input (Pin shared with GPIO6)
STDCLK	I/O	—	—	E2	Clock for serial data output, in the input state after initialization (Pin shared with GPIO5)
SRDCLK	I/O	—	—	F1	Clock for serial data input, in the input state after initialization (Pin shared with GPIO4)

**μPLAT\_SIO I/F**

Pin Name	I/O	Internal Pull Up/Down	Initial Value	Pin Placement	Description
UTXD	O	—	H	F2	Serial data output (Pin shared with GPIO3)
URXD	I	—	—	F4	Serial data input (Pin shared with GPIO2)

**GPIO I/F**

Pin Name	I/O	Internal Pull Up/Down	Initial Value	Pin Placement	Description
GPIO[15:0]	I/O	—	—	[*3]	Parallel I/O data (in the input state after initialization)

**JTAG I/F**

Pin Name	I/O	Internal Pull Up/Down	Initial Value	Pin Placement	Description
TDI	I	Pull down	—	B12	Serial data input
TDO	O	—	L	L12	Serial data output
nTRST	I	Pull down	—	J11	Reset pin
TMS	I	Pull down	—	K12	Mode setting pin
TCK	I	Pull down	—	J13	Serial data clock

**PCM I/F**

Pin Name	I/O	Internal Pull Up/Down	Initial Value	Pin Placement	Description
PCMOUT	O	—	L	D4	PCM data output
PCMIN	I	Pull down	—	A3	PCM data input
PCMSYNC	I/O	Pull down	—	A4	PCM sync signal (8 kHz), in the input state after initialization (can be switched by an internal register)
PCMCLK	I/O	Pull down	—	C4	PCM clock (64 kHz/128 kHz), in the input state after initialization (can be switched by an internal register)

[*3]	CIO15: B2	GPIO15/SOUT (UART I/F)
	CIO14: A2	GPIO14/SIN (UART I/F)
	CIO13: B1	GPIO13/DCD (UART I/F)
	CIO12: C3	GPIO12/RTS (UART I/F)
	CIO11: C1	GPIO11/CTS (UART I/F)
	CIO10: D3	GPIO10/DSR (UART I/F)
	CIO9: E3	GPIO9/DTR (UART I/F)
	CIO8: D2	GPIO8/RI (UART I/F)
	CIO7: E1	GPIO7/STXD (SIO I/F)
	CIO6: E4	GPIO6/SRXD (SIO I/F)
	CIO5: E2	GPIO5/STXDCLK (SIO I/F)
	CIO4: F1	GPIO4/SRXDCLK (SIO I/F)
	CIO3: F2	GPIO3/UTXD (UPLAT_SIO I/F)
	CIO2: F4	GPIO2/URXD (UPLAT_SIO I/F)
	CIO1: F3	GPIO1/NWAIT (Memory I/F)
	CIO0: G3	GPIO0/VBUS (USB I/F)

**TEST I/F**

Pin Name	I/O	Internal Pull Up/Down	Initial Value	Pin Placement	Description
TEST_L	I	—	—	[*4]	Test pin (input)
TEST_O	O	—	L	H13	Test pin (output)
SVCO0	I	—	—	H10	Built-in PLL characteristics setting pin
SVCO1	I	—	—	H12	Built-in PLL characteristics setting pin
VTM	I	—	—	A10	Built-in Flash ROM test pin
CLK	O	—	—	K13	Built-in Flash ROM test pin
NC	—	—	—	A1, A13 N1, N13	No Connection

**Power, GND**

Pin Name	I/O	Internal Pull Up/Down	Initial Value	Pin Placement	Description
V <sub>DD</sub>	—	—	—	[*5]	I/O power pin 3.3 V ±0.3 V
CORE_V <sub>DD</sub>	—	—	—	[*6]	Core power pin 2.5 V ±10%
GND	—	—	—	[*7]	Digital block ground pin
A_V <sub>DD</sub>	—	—	—	F13	Analog block power pin 2.5 V ±10%
A_GND	—	—	—	E10	Analog block ground pin

[\*4] TEST\_L (TEST5): C9  
 TEST\_L (TEST4): B10  
 TEST\_L (TEST3): A9  
 TEST\_L (TEST2): B9  
 TEST\_L (TEST1): A8  
 TEST\_L (TEST0): B8  
 TEST\_L (PLLSEL): J10  
 TSET\_L (PLEN): J12

[\*5] A7, D12, F12, G2, G12, L6

[\*6] B3, C12, D1, D9, H11, K3, L9, L13, N4

[\*7] B5, B11, C2, C6, D11, F10, G1, G4, G10, K6, L1, L7, M4, M13, N9



BLOCK DIAGRAM

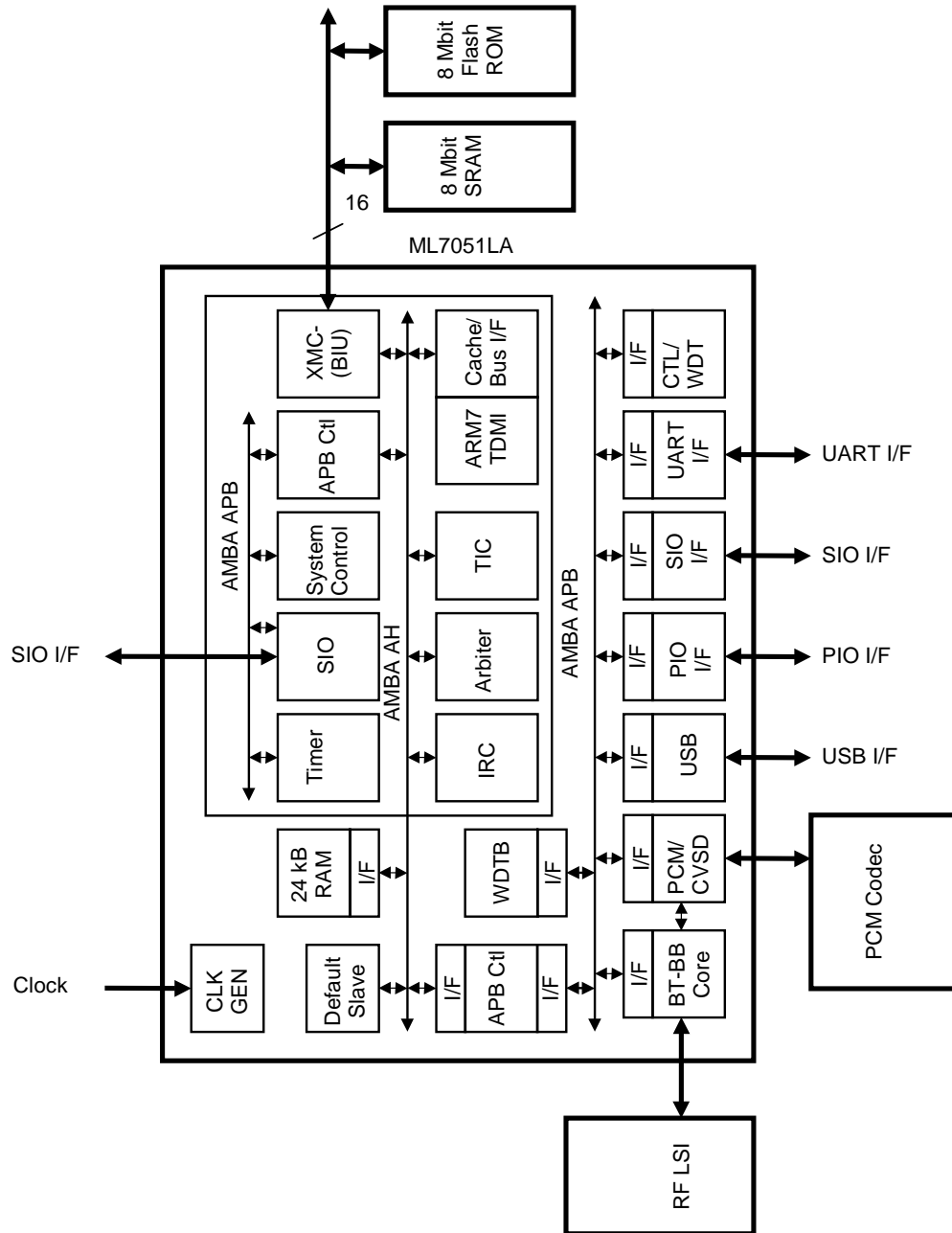

## DESCRIPTION OF INTERNAL BLOCKS

### CLKGEN Block

- Generates from the SCLK12 (12 MHz) clock that is supplied to each block
- STOP/HALT function
- External clock selection function

### CTL/WDT Block

- Control of the frequency division function of the internal main clock
- Control of clock supplied to each peripheral
- Control of reset of each peripheral
- STOP/HALT control
- External clock selection control
- CIO switching function
- Watchdog timer function (interrupt/reset)
- 3 count stop functions

### WDTB Block

- Watchdog timer function (interrupts only)
- 3 count stop functions

### Baseband Core Block

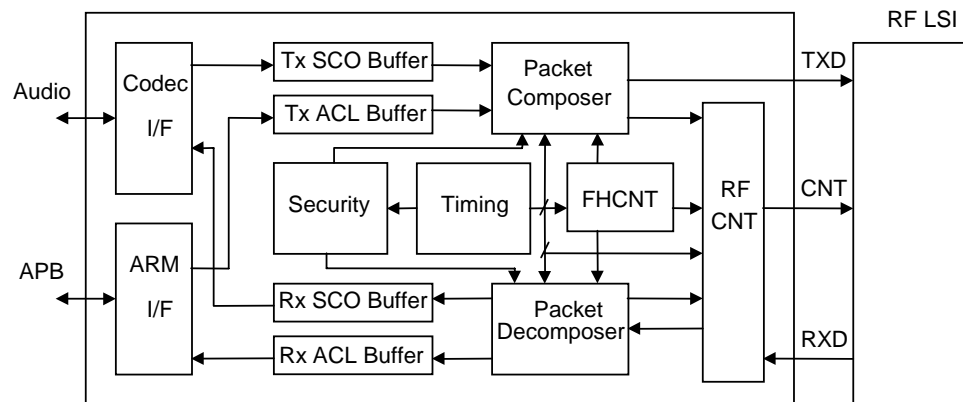

- RF Controller
  - RF power supply control (PLL, TX, RX)
  - Local PLL frequency division ratio setting
  - Receive clock regeneration function
  - Synchronization detection (synchronizing within the permissible error limit of SyncWord)
  - Receive clock re-timing function
- FH Controller hopping
  - Sequence control
  - Frequency hopping selection function
  - CRC computation's initial value selection function

- Timing Generator
  - Bluetooth clock generation
  - Operation interrupts depend on mode (slot, scan, sniff, hold, park)
  - Sync detection timing generation (sync window  $\pm 10 \mu\text{s}$ )
  - PLL setting timing generation
  - Transmit/Receive timing generation
  - Multi-master timing management function
- Packet Composer
  - Access code generation (SyncWord generation, appending PR\*TRAILER)
  - Packet header generation (HEC generation, scrambling, FEC encoding)
  - Payload generation (CRC generation, encryption, scrambling, FEC encoding)
  - Packet synthesis
- Packet Decomposer
  - Packet decomposition (separating the packet header and the payload)
  - Packet header processing (FEC decoding, descrambling, HEC error detection, header information separation)
  - Payload processing (FEC decoding, descrambling, encryption decoding, CRC judgement, payload separation)
- Security
  - Various key generation functions (initialization, link key, encryption key)
  - Certification function
  - Encryption function

#### USB Block

- Conforms to USB standard Ver. 1.1.
- Supports 12 Mbps transfer
- Supports four data transfer types (control transfer, bulk transfer, interrupt transfer, and isochronous transfer)
- Built-in USB transceiver circuit
- 5 or 6 built-in end points, and built-in FIFO for data storage
- 8-, 16-, 24-, 32-bit read/write is possible for the FIFOs of EP0 to EP5 (with byte control)

#### UART Block

- Full-duplex buffering method
- All status reporting function
- Built-in 64-byte transmit/receive FIFO
- Modem control based on CTS, DCD, and DSR
- Programmable serial interface
- 5-, 6-, 7-, 8-bit characters
- Generation and verification of odd parity, even parity, or no parity
- 1, 1.5, or 2 stop bits
- Programmable Baud Rate Generator (1200 bps to 921.6 kbps)
- Error servicing for parity, overrun, and framing errors

**SIO Block**

- UART/Synchronous type serial port interface
- UART Mode:
  - Data length: can be selected as 7 or 8 bits
  - Supports odd parity, even parity, or no parity
  - Error servicing for parity, overrun, and framing errors
  - Supports 1 or 2 stop bits
  - Full-duplex communication is possible
- Clock synchronization mode:
  - Data length: can be selected as 7 or 8 bits
  - Error servicing for overrun errors
  - Full-duplex communication is possible

**μPLAT-SIO Block**

- Start-stop synchronization type serial port interface
- Built-in dedicated baud rate generator
- Data length of 7 or 8 bits can be selected
- 1 or 2 stop bits can be selected.
- Supports odd or even parity
- Error servicing for parity, overrun, and framing errors
- Full-duplex communication is possible

**PCM-CVSD Transcoder Block**

- Application side I/O:
  - PCM Codec
  - APB-Bus (USB)
- Application-side format:
  - PCM linear (8, 16 bits/sample, 64 kHz sampling frequency)/A-law/μ-law
- Bluetooth-side format:
  - CVSD/A-law/μ-law
- All combinations of the above conversions are supported
- PCMSYMC/PCMCLK I/O can be switched (in the input state after initialization)

**GPIO Block**

- All 16 bits
- Input/Output selection possible for each bit
- Interrupts can be used for all 16 bits
- Interrupt masks and interrupt modes can be set for all bits
- In the input state immediately after a reset

## APPLICATION NOTES

### Operation During Boot Up

- Remapping during boot up is performed according to external pins REMAP[1:0].

REMAP1	REMAP0	
L	L	: Reserved
L	H	: Stack Flash ROM
H	L	: Devices connected to external MCS[1]
H	H	: Devices connected to external MCS[0]

- Bit width that corresponds to BANK0 during boot up is set according to external pin BBWSEL.

BBWSEL = L : 8-bit  
 BBWSEL = H : 16-bit

### Clock Selection

- The CPU clock supply source is selected according to external pin SCLKSEL.

SCLKSEL = L : Use 32/16/8/4 MHz clock that was divided down from the internal PLL output of 192 MHz that was generated from external pin SCLK12 (12 MHz). (Initial value is 32 MHz.)  
 SCLKSEL = H : Use external pin XCLK.

Note: The clock supply source can also be set by the CLKCNT register in the CTL/WDT block.

- Bluetooth transmission clock is selected according to external pin TXCSEL.

TXCSEL = L : Use 1 MHz clock that was divided down from the internal PLL output (192 MHz).  
 TXCSEL = H : Use external pin TXC\_IN.

Note: This clock can also be set by the CLKCNT register in the CTL/WDT block.

### HCI Transport Selection

- HCI is selected (USB/UART) according to the logical value of GPIO0 at initial powerup of ML7051LA.

GPIO0 = L : UART is used as HCI.  
 GPIO0 = H : USB is used as HCI.

## USB Peripheral Circuit

- Please refer to the following peripheral circuit example when using USB.

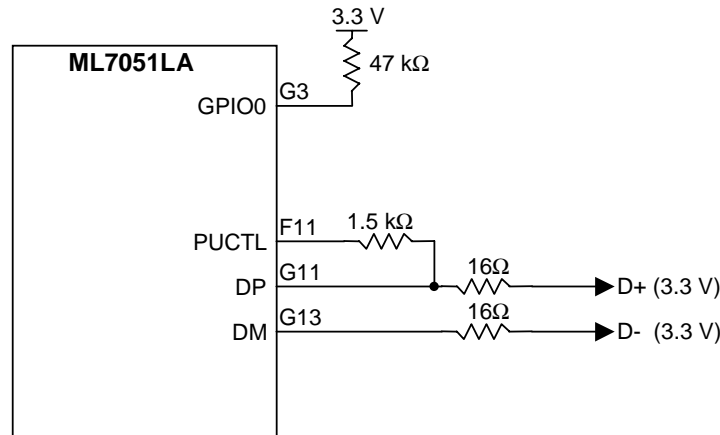

## Setting the UART Baud Rate

- Use the HCI\_VS\_Set\_LC\_Parameters command of the Vendor Specific Commands to set the UART baud rate.

Available baud rate settings:

1200/2400/4800/7200/9600/19.2K/38.4K/56K/57.6K/115.2K/230.4K/345.6K/460.8K/921.6K

(Initial value is 115.2 kbps.)

## Setting the PCM-CVSD Transcoder

- Please use the HCI\_VS\_Set\_LC\_Parameters command of the Vendor Specific Commands in HCI to set the PCM-CVSD transcoder parameters.
- It is possible to set the following parameters using the VCCTL command:
  - PCMSYNC/PCMCLK mode (in the input state after initialization)
  - Mute reception (initial setting: OFF)
  - Mute transmission (initial setting: OFF)
  - Air coding
  - CVSD (initial setting)/ $\mu$ -law/A-law
  - Interface coding
  - Linear (initial setting)/ $\mu$ -law/A-law
  - PCM format (data width of one PCM Linear sample)
    - 8-bit (initial setting)/14-bit/16-bit
  - Serial interface format
    - Short frame (initial setting)/long frame
  - Application interface mode
    - PCM Codec I/F (initial setting)/APB I/F

## External Memory

- ML7051LA specifications for the devices that are connected to MCS[0] and MCS[1] are explained below.
- When connected to MCS[0] device:
  - 1 memory bank
  - Bus width: 8 or 16 bits
  - Byte access control: BS/WE
  - Supported devices:
    - Normal SRAM, Flash Memory, Page mode Flash memory

### Bus timing to MCS[0] device

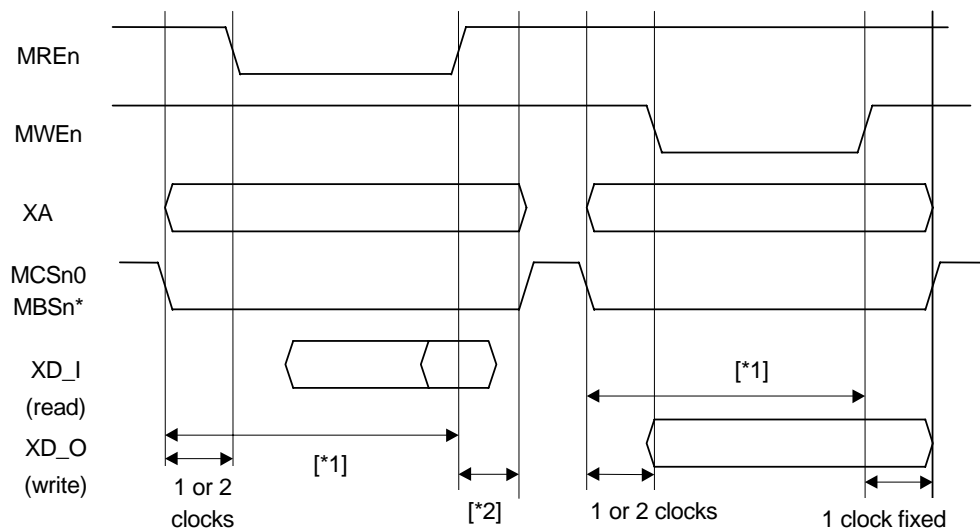

- [\*1] Access time:  
 3, 4, 5, 6, 7, 8 clock cycles (including one clock cycle for set-up)  
 6, 8, 10, 12, 14, 16 clock cycles (including two clock cycles for set-up)
- [\*2] Data OFF time:  
 1, 2, 3, 4 clock cycles

Note: Oki software settings:

- Insert the maximum wait immediately after reset.
- Page mode: OFF
- During operation (32 MHz operation),
  - Access time: 3 clock cycles
  - Data OFF time: 1 clock cycle

Note: A device with an access time of 120 nsec or less is recommended.

- When connected to MCS[1] device:
  - 1 memory bank
  - Bus width: 8-bit or 16-bit
  - Byte access control: BS/WE

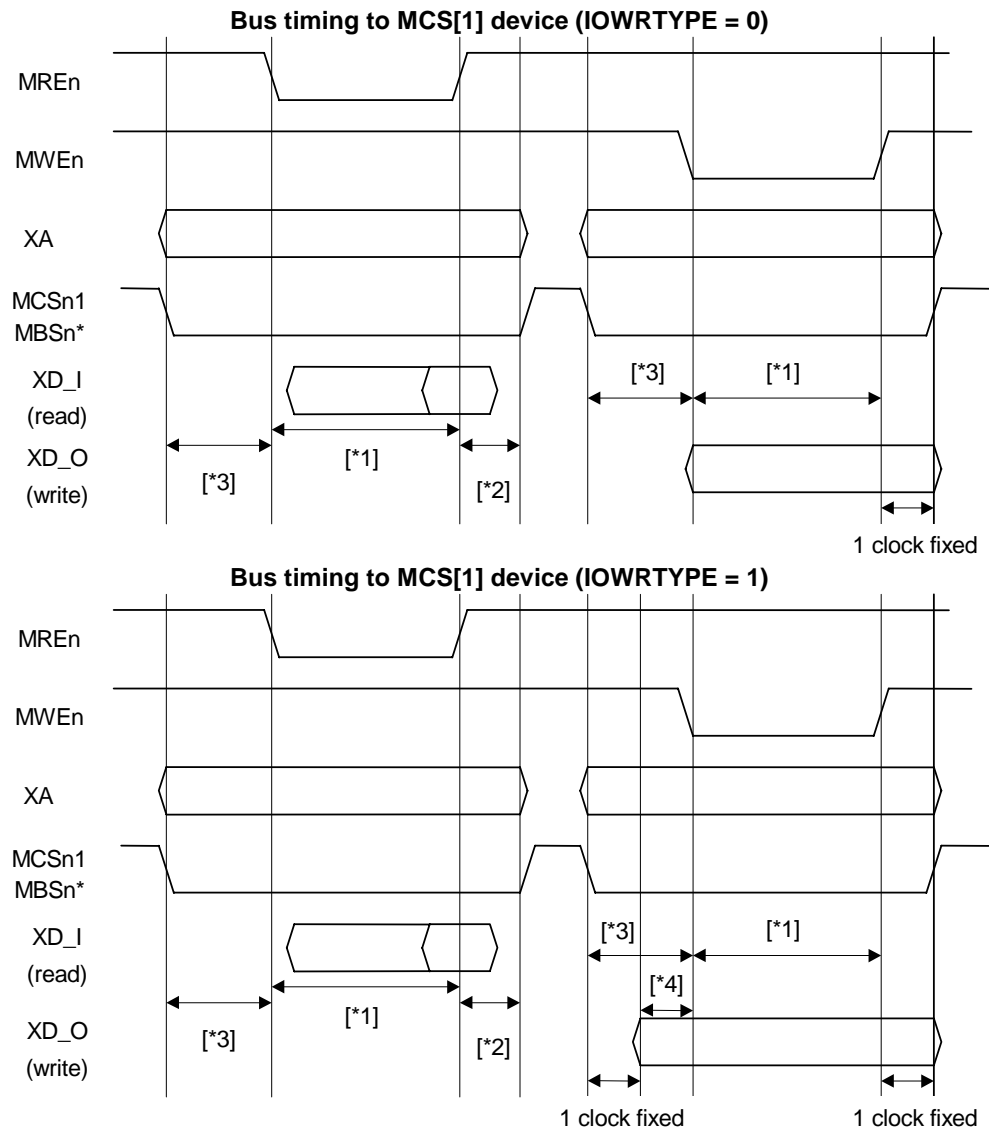

- [\*1] Access time:  
2, 4, 8, 16, 32 clock cycles (including one clock cycle for set-up)  
It is only possible to use the external pin nWAIT then insert a wait period of  $16 \times n$  clock cycles when the 16 cycle clock is selected.
- [\*2] Data OFF time:  
1, 2, 3, 4 clock cycles
- [\*3] Address set-up time:  
1, 2, 3, 4 clock cycles
- [\*4] Write data set-up time:  
0 clock cycles (IOWRTYPE = 0)  
0, 1, 2, 3 clock cycles (IOWRTYPE=1)



- Relationship between address set-up time and write data set-up time (when IOWRTYPE = 1)
  - Address set-up time:
    - 1 clock cycle (write data set-up: 0 clock cycles)
    - 2 clock cycles (write data set-up: 1 clock cycle)
    - 3 clock cycles (write data set-up: 2 clock cycles)
    - 4 clock cycles (write data set-up: 3 clock cycles)

Note: Oki software settings:

- Insert the maximum wait immediately after reset.
- IOWRTYPE = 0
- During operation (32 MHz operation),
  - Access time: 2 clock cycles
  - Data OFF time: 1 clock cycle
  - Address set-up time: 1 clock cycle

Note: A device with an access time of 120 nsec or less is recommended.

- Miscellaneous
  - MA0 is not used with devices that have a 16-bit data bus.  
Connect MA1 to device A0. (MA0 is Open.)
  - Connect MA0 to device A0 for devices that have an 8-bit data bus.
  - MOEn[0] is the AND signal for MCS[0] and MREn.  
Perform an open process when this is not in use.
  - MOEn[1] is the AND signal for MCS[1] and MREn.  
Perform an open process when this is not in use.

**Process when interface pins are unused**

- The following tables show the processes that are performed when interface pins are not used.

**RF I/F**

Pin Name	Process When Pin Not Used	Comments
PLL_DATA	Open	
PLL_CLK	Open	
PLL_LE	Open	
PLL_OFF	Open	
PLL_POW	Open	
TX_POW	Open	
RX_POW	Open	
RSSI	Pull down to GND	
RSSI_CLK	Open	
PLL_PS	Open	
PLLLOCK	Pull down to GND	
RXC	Open	
TXC_IN	Pull down to GND	
TXCSEL	Pull down to GND	

**Memory I/F**

Pin Name	Process When Pin Not Used	Comments
MA[19:0]	Open	<u>When connected</u> For 16-bit devices: <ul style="list-style-type: none"> <li>Open MA0.</li> <li>Connect from MA1 in order from A0 of the connected device.</li> </ul> For 8-bit devices: <ul style="list-style-type: none"> <li>Connect to each corresponding address.</li> </ul>
MD[15:0]	Open	
MWEn	Open	
MREn	Open	
MCSn0	Open	
MCSn1	Open	
MBSn0	Open	
MBSn1	Open	
MOEn0	Open	Only use when connecting to a device that has only one, but not both of CEn or REEn.
MOEn1	Open	
MWAIT	Refer to GPIO1	

**USB I/F**

Pin Name	Process When Pin Not Used	Comments
DP	Open	
DM	Open	
PUCTL	Open	
VBUS (GPIO0)	Pull down/GND	Pull up to Vdd when using USB.

**UART I/F**

Pin Name	Process When Pin Not Used	Comments
SOUT	Refer to GPIO15	
SIN	Refer to GPIO14	
DCD	Refer to GPIO13	
RTS	Refer to GPIO12	
CTS	Refer to GPIO11	
DSR	Refer to GPIO10	
DTR	Refer to GPIO9	
RI	Refer to GPIO8	

**SIO I/F**

Pin Name	Process When Pin Not Used	Comments
STXD	Refer to GPIO7	
SRXD	Refer to GPIO6	
STDCLK	Refer to GPIO5	
SRDCLK	Refer to GPIO4	

**μPLAT\_SIO I/F**

Pin Name	Process When Pin Not Used	Comments
UTXD	Refer to GPIO3	
URXD	Refer to GPIO2	

**GPIO I/F**

Pin Name	Process When Pin Not Used	Comments
GPIO[0]	—	When using UART: Pull down to GND When using USB: Pull up to Vdd
GPIO[15:1]	Pull down/GND	

**JTAG I/F**

Pin Name	Process When Pin Not Used	Comments
TDI	Open	
TDO	Open	
nTRST	Open	
TMS	Open	
TCK	Open	

**PCM I/F**

Pin Name	Process When Pin Not Used	Comments
PCMOUT	Open	
PCMIN	Open	
PCMSYNC	Open	
PCMCLK	Open	

**Processes of Other Pins****TEST I/F, etc.**

Pin Name	Process When Pin Not Used	Comments
TEST_L	GND	
TEST_O	Open	
SVCO0	Pull up to Vdd	
SVCO1	Pull down to GND	
VTM	Open	
CLK	GND	
NC	Open	

### About the Oki Bluetooth Software

- At Oki Electric Industry Co., Ltd., we have made available as Pack 1 the software protocol stack of the lower layer up to HCI that conforms to the Bluetooth Specification Ver. 1.0B for external Flash memory.  
Pack 1 contents: Baseband Controller, LMP, HCI.
- We have also made available packs for the software protocol stack of the upper layer from HCI: Pack 2 (up to RFCOMM) and Pack 3 (including the Middleware).
- Please contact Oki Electric Industry Co., Ltd. for more information regarding software contents, pricing, etc.

### Vendor Specific Commands

- Parameters can be set with the Pack 1 software by using the following Vendor Specific Commands.
- Please contact Oki Electric Industry Co., Ltd. for more information.

- (1) HCI\_VS\_Write\_BD\_ADDR: Sets the BD address.
- (2) HCI\_VS\_Write\_Country\_Code: Sets the country code.
- (3) HCI\_VS\_Set\_LC\_Parameters: Sets the link control information.

The following table shows the link control information that can be set.

Link Control Information	Comments
Unit key	
Use unit key	0: Do not use 1: Use
Channel count	Number of hopping channels
Minimum size of encryption key	
Maximum size of encryption key	
Appropriate size of encryption key	
PCM of SCO link	0: $\mu$ -law, 1: A-law, 2: Linear
UART baud rate	0: 1200 bps 1: 2400 bps 2: 4800 bps 3: 7200 bps 4: 9600 bps 5: 19.2 kbps 6: 38.4 kbps 7: 56 kbps 8: 57.6 kbps 9: 115.2 kbps 9: 230.4 kbps 10: 345.6 kbps 11: 460.8 kbps 12: 921.6 kbps
Polling interval	Unit: 625 $\mu$ sec
Initialization by MaskROM value	

**System Development Kit (SDK)**

- At Oki Electric Industry Co., Ltd., we have made available the System Development Kit (SDK) for the following objectives:
  - Software development of the upper Bluetooth layer
  - Overall system software
  - Device development with embedded ML7050LA or ML7051LA

Please contact Oki Electric Industry Co., Ltd. for more information regarding System Development Kit contents, pricing, etc.

**PACKAGE DIMENSIONS**

(Unit: mm)

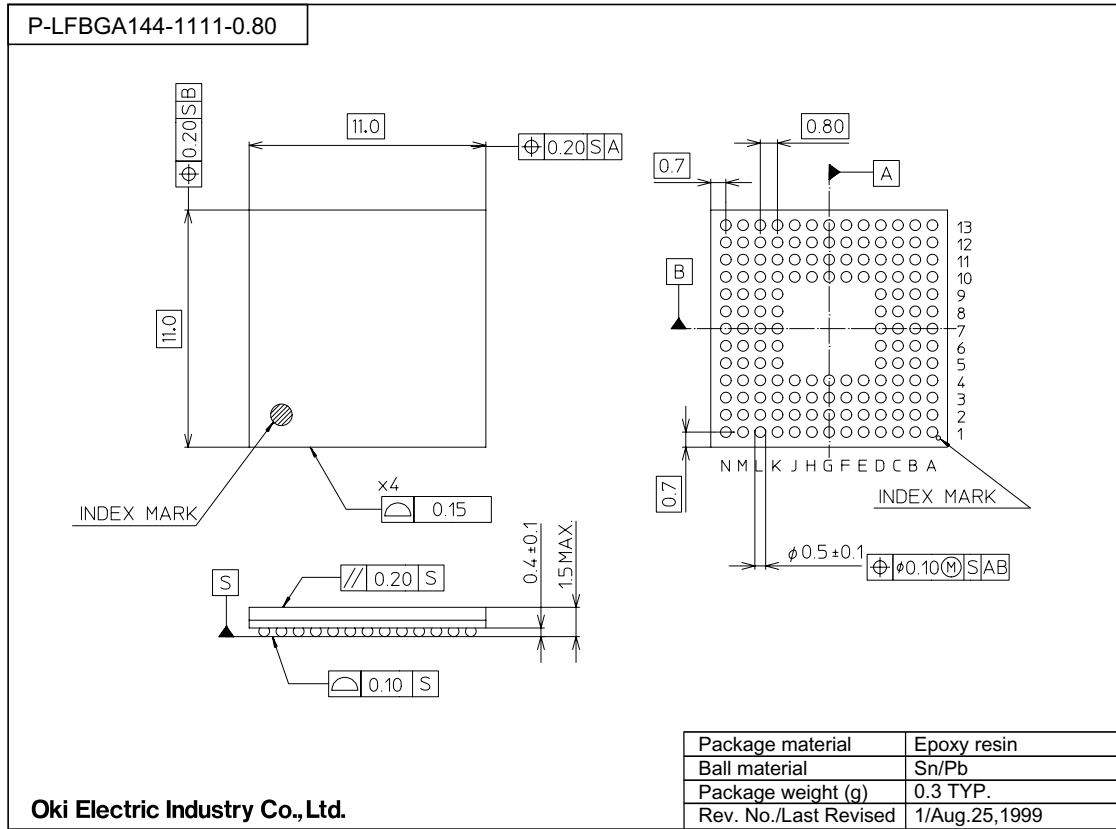

**Notes for Mounting the Surface Mount Type Package**

The surface mount type packages are very susceptible to heat in reflow mounting and humidity absorbed in storage.

Therefore, before you perform reflow mounting, contact Oki's responsible sales person for the product name, package name, pin number, package code and desired mounting conditions (reflow method, temperature and times).

**NOTICE**

1. The information contained herein can change without notice owing to product and/or technical improvements. Before using the product, please make sure that the information being referred to is up-to-date.
2. The outline of action and examples for application circuits described herein have been chosen as an explanation for the standard action and performance of the product. When planning to use the product, please ensure that the external conditions are reflected in the actual circuit, assembly, and program designs.
3. When designing your product, please use our product below the specified maximum ratings and within the specified operating ranges including, but not limited to, operating voltage, power dissipation, and operating temperature.
4. Oki assumes no responsibility or liability whatsoever for any failure or unusual or unexpected operation resulting from misuse, neglect, improper installation, repair, alteration or accident, improper handling, or unusual physical or electrical stress including, but not limited to, exposure to parameters beyond the specified maximum ratings or operation outside the specified operating range.
5. Neither indemnity against nor license of a third party's industrial and intellectual property right, etc. is granted by us in connection with the use of the product and/or the information and drawings contained herein. No responsibility is assumed by us for any infringement of a third party's right which may result from the use thereof.
6. The products listed in this document are intended for use in general electronics equipment for commercial applications (e.g., office automation, communication equipment, measurement equipment, consumer electronics, etc.). These products are not authorized for use in any system or application that requires special or enhanced quality and reliability characteristics nor in any system or application where the failure of such system or application may result in the loss or damage of property, or death or injury to humans. Such applications include, but are not limited to, traffic and automotive equipment, safety devices, aerospace equipment, nuclear power control, medical equipment, and life-support systems.
7. Certain products in this document may need government approval before they can be exported to particular countries. The purchaser assumes the responsibility of determining the legality of export of these products and will take appropriate and necessary steps at their own expense for these.
8. No part of the contents contained herein may be reprinted or reproduced without our prior permission.

Copyright 2000 Oki Electric Industry Co., Ltd.