



GENERAL DESCRIPTION

The AK4651 targeted at PDA and other low-power, small size applications. It features a 16bit stereo CODEC with a built-in Microphone-Amplifier, Headphone-Amplifier and Speaker-Amplifier. Input circuits include a Microphone-Amplifier and an ALC (Auto Level Control) circuit. The AK4651 is connected with AC'97 controller (CPU) via AC-Link. The AK4651 is available in a very small 57pin BGA, utilizing less board space than competitive offerings.

FEATURES

1. Resolution: 16bits
2. Recording Function
 - Mono Input (Single-ended or Differential Input)
 - 2 to 1 Selector (Internal and External MIC)
 - MIC Power: 2 outputs (Internal and External MIC)
 - 1st MIC Amplifier: +20dB or 0dB
 - 2nd Amplifier with ALC: +27.5dB ~ -8dB, 0.5dB Step
 - ADC Performance (@MIC-Amp=+20dB, Single-ended):
S/(N+D): 79dB, DR, S/N: 83dB
 - MIC Detection
3. Playback Function
 - Digital De-emphasis Filter (tc=50/15 μ s, fs=32kHz, 44.1kHz, 48kHz)
 - Digital Volume (0dB ~ -63dB, 0.5dB Step, Mute)
 - Bass Boost
 - Mono Output
 - Full-differential Output
 - S/(N+D): 85dB, S/N: 95dB
 - Analog Volume: +6dB ~ -15dB, 3dB Step
 - Headphone-Amp
 - Output Power: 40mW@16 Ω (HVDD=3.3V)
 - S/(N+D): 60dB@10mW, S/N: 90dB
 - Headphone Jack Detection
 - Mono Speaker-Amp
 - Output Power: 300mW@8 Ω (HVDD=3.3V, ALC2=OFF)
 - S/(N+D): 55dB@110mW, S/N: 90dB
 - BTL Output
 - ALC (Auto Level Control) circuit
 - Mono Beep Input
 - AUX Input
 - Full-differential Input
 - Analog Volume: +12dB ~ -34.5dB, 1.5dB Step, Mute
 - Stereo Line Input
 - Single-ended Input
 - Analog Volume: +12dB ~ -34.5dB, 1.5dB Step, Mute

4. System Clock: 24.576MHz, 12MHz, 3.6864MHz
5. Sampling Rate: 48kHz, 44.1kHz, 32kHz, 24kHz, 22.05kHz, 16kHz, 11.025kHz, 8kHz
6. Power Management
7. Audio & Control I/F: AC-Link I/F
8. Ta = -30 ~ 85°C
9. Power Supply: 2.7V ~ 3.6V (typ. 3.3V)
10. Package: 57pin BGA (5mm x 5mm)
11. AK4650 Pin Compatible

■ Block Diagram

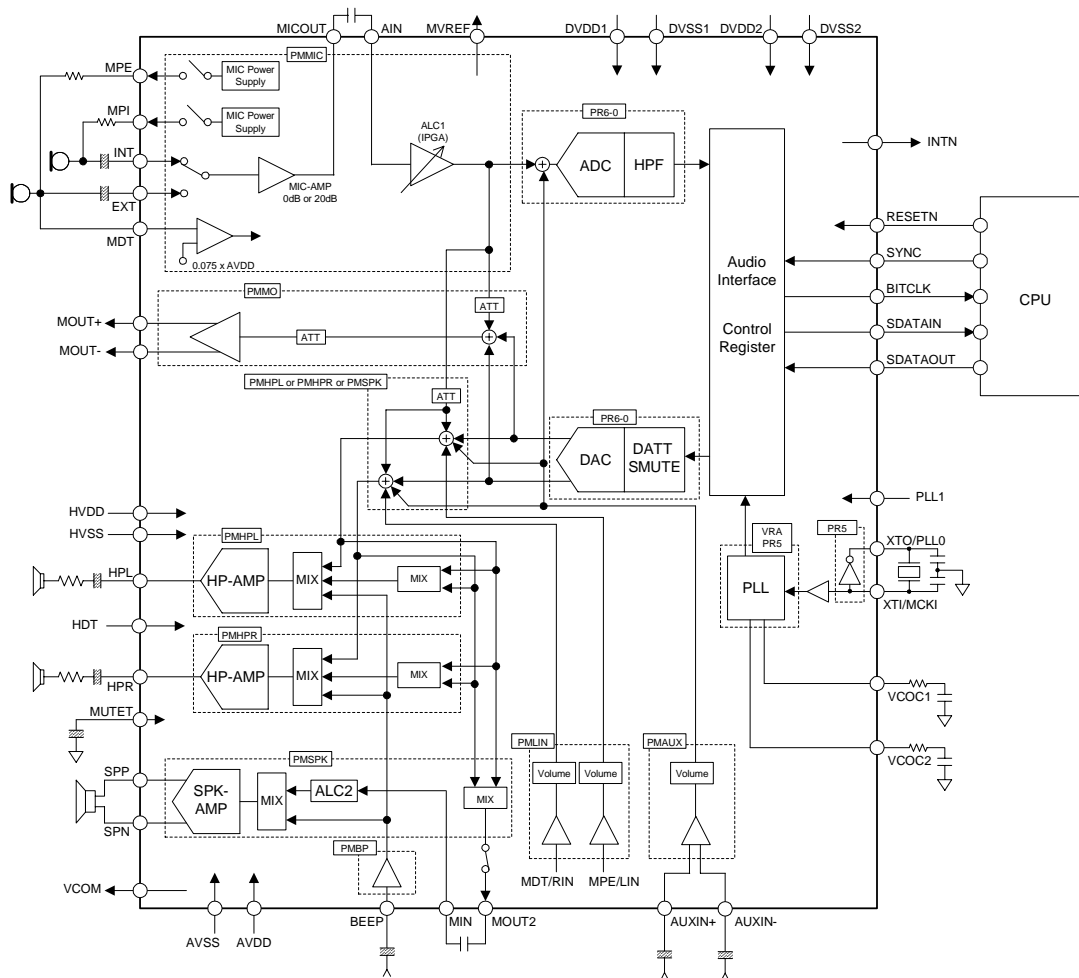

Figure 1. Block Diagram

■ Ordering Guide

AK4651VG
AKD4651

-30 ~ +85°C 57pin BGA (0.5mm pitch)
Evaluation board for AK4651

■ Pin Layout

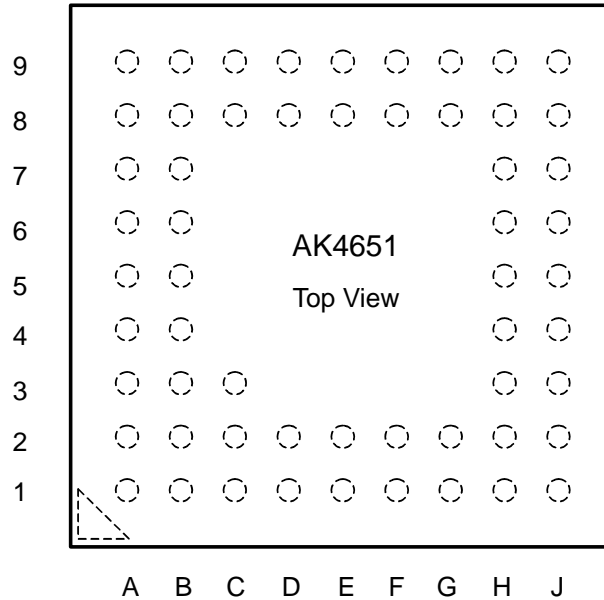

9	NC	BEEP/IN2	AVDD	VCOM	AUXIN+	MPI	EXT/MIC+	MPE/LIN	NC
8	VCOC1	VCOC2	AVSS	MVREF	AUXIN-	INT/MIC-	MDT/RIN	AIN	MICOUT
7	TEST2	AVDD2	Top View					MOUT-	MOUT+
6	TEST3	TEST4						HPL	HPR
5	TEST5	AVSS2						HVSS	HVDD
4	TEST7	TEST6						SPP	SPN
3	TEST9	TEST8						NC	MUTET
2	TEST10	INTN	XTO/PLL0	SDATA OUT	DVSS2	SDATAIN	SYNC	MOUT2	MIN
1	NC	DVDD1	XTI/MCKI	DVSS1	BITCLK	DVDD2	RESETN	PLL1	TEST
	A	B	C	D	E	F	G	H	J

PIN/FUNCTION			
No.	Pin Name	I/O	Function
A1	NC	-	No Connect Pin No internal bonding. This pin should be open or connected to the ground.
B1	DVDD1	-	Digital Power Supply 1 Pin
C1	XTI	I	X'tal Input Pin
	MCKI	I	External Master Clock Input Pin
C2	XTO	O	X'tal Output Pin (PLL1 pin = "L")
	PLL0	I	PLL Input Master Clock Frequency Select 0 Pin (PLL1 pin = "H") "L": 3.6864MHz, "H": 12MHz
D1	DVSS1	-	Digital Ground 1 Pin
D2	SDATAOUT	I	Serial 256-bit AC'97 data stream from digital controller
E1	BITCLK	O	12.288MHz(256fs) serial data clock
E2	DVSS2	-	Digital Ground 2 Pin
F2	SDATAIN	O	Serial 256-bit AC'97 data stream to digital controller
F1	DVDD2	-	Digital Power Supply 2 Pin
G2	SYNC	I	AC'97 Sync Clock, 48kHz(1fs) fixed rate sampling rate
G1	RESETN	I	AC'97 Master Hardware Reset
H1	PLL1	I	PLL Input Master Clock Frequency Select 1 Pin "L": 24.576MHz (PLL0 pin = "L") "H": 3.6864MHz (PLL0 pin = "L") or 12MHz (PLL0 pin = "H") When PLL1 pin = "H", X'tal oscillation circuit is not available.
J1	TEST	-	Test Pin This pin should be connected to the ground.
J2	MIN	I	ALC Input Pin
H2	MOUT2	O	Analog Mixing Output Pin
H3	MUTET	O	Mute Time Constant Control Pin Connected to HVSS pin with a capacitor for mute time constant.
J3	HDT	I	Headphone Detect Pin (Internal pull up by 100kΩ)
H4	SPP	O	Speaker Amp Positive Output Pin
J4	SPN	O	Speaker Amp Negative Output Pin
H5	HVSS	-	Headphone & Speaker Amp Ground Pin
J5	HVDD	-	Headphone & Speaker Amp Power Supply Pin
J6	HPR	O	Rch Headphone Amp Output Pin
H6	HPL	O	Lch Headphone Amp Output Pin
H7	MOUT-	O	Mono Line Negative Output Pin
J7	MOUT+	O	Mono Line Positive Output Pin
H8	AIN	I	Analog Input Pin
J9	NC	-	No Connect Pin No internal bonding. This pin should be open or connected to the ground.

No.	Pin Name	I/O	Function
J8	MICOUT	O	Microphone Analog Output Pin
G8	MDT	I	Microphone Detect Pin (Internal pull down by 500kΩ) (RNMD bit = "0")
	RIN	I	Rch Line Input Pin (RNMD bit = "1")
H9	MPE	O	MIC Power Supply Pin for External Microphone (LNMP bit = "0")
	LIN	I	Lch Line Input Pin (LNMP bit = "1")
G9	EXT	I	External Microphone Input Pin (Single-ended Input: MDIF bit = "0")
	MIC+	I	Microphone Positive Input Pin (Differential Input: MDIF bit = "1")
F8	INT	I	Internal Microphone Input Pin (Single-ended Input: MDIF bit = "0")
	MIC-	I	Microphone Negative Input Pin (Differential Input: MDIF bit = "1")
F9	MPI	O	MIC Power Supply Pin for Internal Microphone
E8	AUXIN-	I	Mono AUX Negative Input Pin
E9	AUXIN+	I	Mono AUX Positive Input Pin
D8	MVREF	O	MIC Power Supply Reference Voltage Output Pin
D9	VCOM	O	Common Voltage Output Pin Bias voltage of ADC inputs and DAC outputs.
C8	AVSS2	-	Analog Ground 2 Pin
C9	AVDD2	-	Analog Power Supply 2 Pin
B9	BEEP	I	Mono Beep Signal Input Pin
A9	NC	-	No Connect Pin No internal bonding. This pin should be open or connected to the ground.
A8	VCOC1	O	Output 1 Pin for Loop Filter of PLL Circuit This pin should be connected to DVSS with a resistor (10kΩ) and a capacitor (4.7nF) in series.
B8	VCOC2	O	Output 1 Pin for Loop Filter of PLL Circuit This pin should be connected to DVSS with a resistor (10kΩ) and a capacitor (4.7nF) in series.

Note: All input pins except analog input pins should not be left floating (XTI/MCKI, PLL0, SDATAOUT, SYNC, RESETN and PLL1 pins).

No.	Pin Name	I/O	Function
B7	AVDD2	-	Analog Power Supply 2 Pin
A7	TEST2	-	Test 2 Pin This pin should be floating.
A6	TEST3	-	Test 3 Pin This pin should be floating.
B6	TEST4	-	Test 4 Pin This pin should be floating.
A5	TEST5	-	Test 5 Pin This pin should be floating.
B5	AVSS2	-	Touch Screen Controller Ground Pin
B4	TEST6	-	Test 6 Pin This pin should be floating.
A4	TEST7	-	Test 7 Pin This pin should be floating.
B3	TEST8	-	Test 8 Pin This pin should be floating.
A3	TEST9	-	Test 9 Pin This pin should be floating.
B2	INTN	O	Headphone Jack Detect Interrupt Output Pin This pin should be pulled up via a 100k Ω resistor.
A2	TEST10	-	Test 10 Pin This pin should be connected to the ground.
C3	NC	-	No Connect Pin No internal bonding. This pin should be open or connected to the ground.

■ Handling of Unused Pin

The unused I/O pins should be processed appropriately as below.

Classification	Pin Name	Setting
Analog	MIN, MOUT2, MUTET, HDT, SPP, SPN, HPR, HPL, MOUT-, MOUT+, AIN, MICOUT, MDT/RIN, MPE/LIN, EXT/MIC+, INT/MIC-, MPI, AUXIN-, AUXIN+, BEEP, INTN	These pins should be open.
Digital	XTO	This pin should be open.

ABSOLUTE MAXIMUM RATINGS

(AVSS, DVSS, HVSS=0V; Note 1, Note 2)

Parameter	Symbol	min	max	Units	
Power Supplies:	Analog (Note 3)	AVDD	-0.3	6.0	V
	Digital (Note 4)	DVDD	-0.3	6.0	V
	Headphone-Amp / Speaker-Amp	HVDD	-0.3	6.0	V
	AVSS – DVSS (Note 5)	ΔGND1	-	0.3	V
	AVSS – HVSS (Note 5)	ΔGND2	-	0.3	V
Input Current, Any Pin Except Supplies	IIN	-	±10	mA	
Analog Input Voltage	(Note 6)	VINA1	-0.3	AVDD+0.3	V
	(Note 7)	VINA2	-0.3	HVDD+0.3	V
Digital Input Voltage	(Note 8)	VIND	-0.3	DVDD+0.3	V
Ambient Temperature (powered applied)	Ta	-30	85	°C	
Storage Temperature	Tstg	-65	150	°C	

Note 1. All voltages with respect to ground.

Note 2. AVSS means AVSS1 and AVSS2. DVSS means DVSS1 and DVSS2.

Note 3. AVDD means AVDD1 and AVDD2.

Note 4. DVDD means DVDD1 and DVDD2.

Note 5. AVSS, DVSS and HVSS must be connected to the same analog ground plane.

Note 6. MIN, AIN, MDT/RIN, MPE/LIN, EXT/MIC+, INT/MIC-, AUXIN-, AUXIN+, BEEP pins

Note 7. HDT pin

Note 8. XT/MCKI, XTO/PLL0, SDATAOUT, SYNC, RESETN, PLL1 pins

WARNING: Operation at or beyond these limits may result in permanent damage to the device.
Normal operation is not guaranteed at these extremes.

RECOMMENDED OPERATING CONDITIONS

(AVSS, DVSS, HVSS=0V; Note 1, Note 2)

Parameter	Symbol	min	typ	max	Units	
Power Supplies: (Note 9)	Analog (Note 3)	AVDD	2.7	3.3	3.6	V
	Digital (Note 4)	DVDD	2.7	3.3	AVDD	V
	HP / SPK-Amp	HVDD	2.7	3.3	3.6	V

Note 1. All voltages with respect to ground. DVDD1 and DVDD2 should be same voltage.

Note 2. AVSS means AVSS1 and AVSS2. DVSS means DVSS1 and DVSS2.

Note 3. AVDD means AVDD1 and AVDD2.

Note 4. DVDD means DVDD1 and DVDD2.

Note 9. The power up sequence between AVDD, DVDD and HVDD is not critical. When the voltage difference among AVDD, DVDD and HVDD is larger than 0.3V, the power supply current at power down mode increases (see Note 28). When the power supplies are partially powered OFF, the AK4651 must be reset by bringing PDN pin "L" after these power supplies are powered ON again. DVDD1 and DVDD2 should be same voltage.

* AKM assumes no responsibility for the usage beyond the conditions in this datasheet.

ANALOG CHARACTERISTICS					
(Ta=25°C; AVDD, DVDD, HVDD=3.3V; AVSS=DVSS=HVSS=0V; fs=48kHz; Signal Frequency=1kHz; 16bit Data; Measurement frequency=20Hz ~ 20kHz; unless otherwise specified)					
Parameter	min	typ	max	Units	
MIC Amplifier: INT, EXT pins, MDIF bit = "0" (Single-ended input)					
Input Resistance	20	30	40	kΩ	
Gain	(MGAIN bit = "0")	0	-	dB	
	(MGAIN bit = "1")	+20	-	dB	
MIC Amplifier: MIC+, MIC- pins, MDIF bit = "1" (Full-differential input), MGAIN bit = "1" (+20dB)					
Maximum Input Voltage (Note 10)	-	0.099	-	Vpp	
MIC Power Supply: MPI, MPE pins					
Output Voltage	1.98	2.2	2.42	V	
Load Resistance	2	-	-	kΩ	
Load Capacitance	-	-	30	pF	
Mic Detection: MDT pin					
Comparator Voltage Level	0.15	0.20	0.23	V	
Internal pull down Resistance	250	500	750	kΩ	
Input PGA Characteristics: AIN pin					
Input Resistance (Note 11)	5	10	15	kΩ	
Step Size	0.1	0.5	0.9	dB	
Gain Control Range (ALC1 bit = "0")					
	max: IPGA6-0 bits = "3FH"	-	+27.5	-	dB
	min: IPGA6-0 bits = "00H"	-	-8	-	dB
ADC Analog Input Characteristics: MIC Gain=+20dB, IPGA=0dB, ALC1=OFF, MIC → IPGA → ADC					
Resolution	-	-	16	Bits	
Input Voltage (Note 12)	0.168	0.198	0.228	Vpp	
S/(N+D) (-1dBFS)	71	79	-	dB	
D-Range (-60dBFS, A-weighted)	75	83	-	dB	
S/N (A-weighted)	75	83	-	dB	
DAC Characteristics:					
Resolution	-	-	16	Bits	
Mono Line Output Characteristics: RL=20kΩ, DAC → MOUT+/MOUT- pins, MOGN2-0 bits = +6dB					
Output Voltage (Note 13)	3.56	3.96	4.36	Vpp	
S/(N+D) (-3dBFS)	75	85	-	dB	
S/N (A-weighted)	85	95	-	dB	
Load Resistance	20	-	-	kΩ	
Load Capacitance	-	-	30	pF	
Step Size	2	3	4	dB	
Gain Control Range					
	max: MOGN2-0 bits = "111"	-	+6	-	dB
	min: MOGN2-0 bits = "000"	-	-15	-	dB

Note 10. Maximum input voltage of MIC+ and MIC- pins are proportional to AVDD voltage. Vin = 0.03 x AVDD(typ).

Note 11. When IPGA Gain is changed, this typical value changes between 8kΩ and 11kΩ.

Note 12. Input voltage is proportional to AVDD voltage. Vin = 0.06 x AVDD.

Note 13. Output voltage is proportional to AVDD voltage. Vout = 1.2 x AVDD(typ)@MOGN2-0 bits = "111" at full-differential output. Vout = 0.6 x AVDD(typ)@MOGN2-0 bits = "111" at single-ended Output.

Parameter		min	typ	max	Units
Headphone-Amp Characteristics: $R_L=16\Omega$, DAC → HPL/HPR pins, DATT=0dB					
Output Voltage (Note 14)	0dBFS Input	-	0.82	-	V _{rms}
	-6dBFS Input	0.32	0.41	0.50	V _{rms}
S/(N+D)	0dBFS Input	-	35	-	dB
	-6dBFS Input	50	60	-	dB
S/N (A-weighted)		80	90	-	dB
Interchannel Isolation (-6dBFS Input)		60	85	-	dB
Interchannel Gain Mismatch (-6dBFS Input)		-	0.1	-	dB
Load Resistance		16	-	-	Ω
Load Capacitance (Note 15)		-	-	300	pF
Headphone Detection: HDT pin					
Comparator Voltage Level (Note 16)		0.99	-	2.31	V
Internal pull up Resistance		50	100	150	k Ω
Speaker-Amp Characteristics: $R_L=8\Omega$, BTL, DAC → MOUT2 pin → MIN pin → SPP/SPN pins, ALC2=OFF					
Output Voltage (Note 17)	-2.5dBFS Input	-	1.55	-	V _{rms}
	-7.5dBFS Input	0.75	0.94	1.13	V _{rms}
S/(N+D)	-2.5dBFS Input	-	20	-	dB
	-7.5dBFS Input	40	55	-	dB
S/N (A-weighted)		80	90	-	dB
Load Resistance		8	-	-	Ω
Load Capacitance		-	-	30	pF
Mono Output: DAC → MIX → MOUT2 pin					
Output Voltage (Note 18)		-	1.98	-	V _{pp}
Load Resistance (Note 19)		30	-	-	k Ω
Load Capacitance (Note 15, Note 19)		-	-	20	pF
Mono Input: MIN pin					
Maximum Input Voltage (Note 20)		-	1.98	-	V _{pp}
Input Resistance (Note 21)		12	24	36	k Ω
BEEP Input: BEEP pin, External input resistance = 20k Ω					
Maximum Input Voltage (Note 22)		-	1.98	-	V _{pp}
Feedback Resistance		-	20	-	k Ω
Output Voltage (0.8V _{pp} input)					
	BEEP pin → HPL/HPR pins	0.045	0.09	0.135	V _{pp}
	BEEP pin → SPP/SPN pins, ALC2 bit = "0"	1.26	2.53	3.80	V _{pp}

Note 14. Output voltage is proportional to AVDD voltage. $V_{out} = 0.12 \times AVDD \text{ V}_{rms}(typ) @ -6dBFS$.

Note 15. When the output pin drives a capacitive load, a resistor should be added in series between the output pin and capacitive load.

Note 16. Comparator Voltage Level is proportional to HVDD voltage. $V_{th} = 0.3 \times HVDD(\min)$, $0.7 \times HVDD(\max)$.

Note 17. Output voltage is proportional to HVDD voltage. $V_{out} = 0.28 \times AVDD \text{ V}_{rms}(typ) @ -6dBFS$ at Full-differential output.

Note 18. Output Voltage is proportional to AVDD voltage. $V_{out} = 0.6 \times AVDD(typ)$.

Note 19. These values do not include the input resistance or capacitance of the MIN pin.

Note 20. Maximum Input Voltage is proportional to AVDD voltage. $V_{in} = 0.6 \times AVDD(typ)$.

Note 21. When ALC2 Gain is changed, this typical value changes between 22k Ω and 26k Ω .

Note 22. Maximum Input Voltage depends on AVDD voltage, internal feedback resistance (R_f) and external input resistance (R_i). $V_{in} = 0.6 \times AVDD \times R_i / R_f (typ)$.

Parameter	min	typ	max	Units
Line Input: LIN, RIN pins				
Maximum Input Voltage (Note 23)	-	1.98	-	V _{pp}
Input Resistance	25	40	55	kΩ
Step Size	0.5	1.5	2.5	dB
Gain Control Range				
(max: GL4-0 bits = "00H")	-	+12	-	dB
(min: GL4-0 bits = "1FH")	-	-34.5	-	dB
AUX Input: AUXIN+, AUXIN- pins				
Maximum Input Voltage (Note 24)	-	1.98	-	V _{pp}
Input Resistance				
AUXIN+ pin	25	40	55	kΩ
AUXIN- pin	50	80	110	kΩ
Step Size	0.5	1.5	2.5	dB
Gain Control Range				
(max: GN4-0 bits = "00H")	-	+12	-	dB
(min: GN4-0 bits = "1FH")	-	-34.5	-	dB
Power Supplies:				
Power Up (RESETN pin = "H")				
All Circuit Power-up:				
AVDD+DVDD (Note 25)	-	15	23	mA
HVDD: HP-AMP Normal Operation No Output (Note 26)	-	2.5	5	mA
HVDD: SPK-AMP Normal Operation No Output (Note 27)	-	7	21	mA
Power Down (RESETN pin = "L") (Note 28)				
AVDD+DVDD+HVDD	-	1	100	μA

Note 23. Maximum Input Voltage is proportional to AVDD voltage. $V_{in} = 0.6 \times AVDD(\text{typ})$.

Note 24. Maximum Input Voltage is proportional to AVDD voltage. $V_{in} = (AUXIN+) - (AUXIN-) = 0.6 \times AVDD(\text{typ})$.

Note 25. PR0-6 bits = all "0", PMMIC=PMMO=PMSPK=PMHPL=PMHPR=PMBPM=PMAUX=PMLIN= "1".

AVDD=10mA (typ.), DVDD=5mA (typ.).

Note 26. PR0-6 bits = all "0", PMMIC=PMMO=PMHPL=PMHPR=PMBPM=PMAUX=PMLIN= "1", PMSPK= "0".

Note 27. PR0-6 bits = all "0", PMMIC=PMMO=PMSPK=PMBPM=PMAUX=PMLIN= "1", PMHPL=PMHPR= "0".

Note 28. All digital input pins are fixed to DVDD or DVSS. When the voltage difference among AVDD, DVDD and HVDD is larger than 0.3V, the power supply current at power down mode increases.

FILTER CHARACTERISTICS							
(Ta=25°C; AVDD, HVDD, DVDD=2.7 ~ 3.6V; fs=48kHz; DEM=OFF)							
Parameter		Symbol	min	typ	max	Units	
ADC Digital Filter (Decimation LPF):							
Passband (Note 29)	±0.1dB	PB	0	-	18.9	kHz	
	-1.0dB		-	21.8	-	kHz	
	-3.0dB		-	23.0	-	kHz	
Stopband		SB	29.4	-	-	kHz	
Passband Ripple		PR	-	-	±0.1	dB	
Stopband Attenuation		SA	65	-	-	dB	
Group Delay (Note 30)		GD	-	17.0	-	1/fs	
Group Delay Distortion		ΔGD	-	0	-	μs	
ADC Digital Filter (HPF):							
Frequency Response (Note 29)	-3.0dB	FR	-	1.0	-	Hz	
	-0.1dB		-	6.5	-	Hz	
DAC Digital Filter:							
Passband (Note 29)	±0.1dB	PB	0	-	21.3	kHz	
	-6.0dB		-	24.0	-	kHz	
Stopband		SB	25.2	-	-	kHz	
Passband Ripple		PR	-	-	±0.01	dB	
Stopband Attenuation		SA	59	-	-	dB	
Group Delay (Note 30)		GD	-	16.8	-	1/fs	
DAC Digital Filter + SCF:							
Frequency Response: 0 ~ 20.0kHz		FR	-	±1.0	-	dB	
BOOST Filter: (Note 31)							
Frequency Response	MIN	20Hz	FR	-	5.80	-	dB
		100Hz		-	3.17	-	dB
		1kHz		-	0.03	-	dB
	MID	20Hz	FR	-	10.85	-	dB
		100Hz		-	7.23	-	dB
		1kHz		-	0.18	-	dB
	MAX	20Hz	FR	-	16.14	-	dB
		100Hz		-	11.05	-	dB
		1kHz		-	0.47	-	dB

Note 29. The passband and stopband frequencies scale with fs (system sampling rate).

For example, ADC is PB=0.454 × fs (@-1.0dB). The reference frequency of these responses is 1kHz.

Note 30. The calculated delay time caused by digital filtering. This time is from the input of analog signal to setting of the 16-bit data of both channels from the input register to the output register of the ADC. This time includes the group delay of the HPF. For the DAC, this time is from setting the 16-bit data of both channels from the input register to the output of analog signal.

Note 31. These frequency responses scale with fs. If a high-level and low frequency signal is input, the analog output clips to the full-scale.

DC CHARACTERISTICS

(Ta=25°C; AVDD, HVDD, DVDD=2.7 ~ 3.6V)

Parameter	Symbol	min	typ	Max	Units
High-Level Input Voltage	V _{IH}	70% DVDD	-	-	V
Low-Level Input Voltage	V _{IL}	-	-	30% DVDD	V
Input Voltage at AC Coupling (Note 32)	V _{AC}	50% DVDD	-	-	V
High-Level Output Voltage (I _{out} =-400μA)	V _{OH}	DVDD-0.4	-	-	V
Low-Level Output Voltage (I _{out} =400μA)	V _{OL}	-	-	0.4	V
Input Leakage Current	I _{in}	-	-	±10	μA
INTN "L" level output voltage (100kΩ Pull-Up)	V _{OLP}	-	-	0.8	V

Note 32. When AC coupled capacitor is connected to MCKI pin.

SWITCHING CHARACTERISTICS

(Ta=25°C; AVDD, HVDD, DVDD=2.7 ~ 3.6V; CL=25pF)

Parameter	Symbol	min	typ	max	Units
Master Clock Timing					
Frequency					
PLL1 pin = "L", PLL0 pin = "L"	Fmclk	-	24.576	-	MHz
PLL1 pin = "H", PLL0 pin = "L"	Fmclk	-	3.6864	-	MHz
PLL1 pin = "H", PLL0 pin = "H"	Fmclk	-	12	-	MHz
Duty Cycle	Dmclk	40	-	60	%
AC link Interface Timing					
BITCLK frequency	Fbclk	-	12.288	-	MHz
BITCLK clock Period(Tbclk=1/Fbclk)	Tbclk	-	81.38	-	ns
BIT_BLK low pulse width	Tclk_low	36	40.7	45	ns
BIT_BLK high pulse width	Tclk_high	36	40.7	45	ns
BITCLK rise time	Trise_clk	-	-	6	ns
BITCLK fall time	Tfall_clk	-	-	6	ns
SYNC frequency	Fsync	-	48	-	kHz
SYNC low pulse width	Tsync_low	-	19.5	-	μs
			(240 cycle)		(Tbclk)
SYNC high pulse width	Tsync_high	-	1.3	-	μs
			(16 cycle)		(Tbclk)
SYNC rise time	Trise_sync	-	-	6	ns
SYNC fall time	Tfall_sync	-	-	6	ns
Setup time(SYNC, SDATAOUT)	Tsetup	14	-	-	ns
Hold time(SYNC, SDATAOUT)	Thold	25	-	-	ns
SDATAIN delay time from BITCLK rising edge	Tdelay	-	-	15	ns
SDATAIN rise time	Trise_din	-	-	6	ns
SDATAIN fall time	Tfall_din	-	-	6	ns
SDATAOUT rise time	Trise_dout	-	-	6	ns
SDATAOUT fall time	Tfall_dout	-	-	6	ns
Cold Reset (SDATAOUT = "L", SYNC = "L")					
RESETN active low pulse width	Trst_low	1.0	-	-	μs
RESETN inactive to BITCLK delay					
PLL1 pin = "L" (External clock)	Trst2clk	-	42	-	μs
PLL1 pin = "L" (X'tal oscillator)	Trst2clk	-	0.5	-	ms
PLL1 pin = "H", PLL0 pin = "L"	Trst2clk	-	9.5	-	ms
PLL1 pin = "H", PLL0 pin = "H"	Trst2clk	-	3.2	-	ms
Warm Reset Timing					
SYNC active high pulse width	Tsync_high	1.0	1.3	-	μs
			(16 cycle)		(Tbclk)
SYNC inactive to BITCLK delay					
PLL1 pin = "L" (External clock)	Trst2clk	-	42	-	μs
PLL1 pin = "L" (X'tal oscillator)	Tsync2clk	-	0.5	-	ms
PLL1 pin = "H", PLL0 pin = "L"	Tsync2clk	-	9.5	-	ms
PLL1 pin = "H", PLL0 pin = "H"	Tsync2clk	-	3.2	-	ms
AC-link Low Power Mode Timing					
End of Slot 2 to BITCLK, SDATAIN Low	Ts2_pdwn	-	-	1.0	μs
Activate Test Mode Timing					
Setup to trailing edge of RESETN	Tsetup2rst	15.0	-	-	ns
Hold from RESETN rising edge	Thold2rst	100	-	-	ns
Rising edge of RESETN to Hi-Z	Toff	-	-	50	ns
Falling edge of RESETN to "L"	Tlow	-	-	50	ns

■ Timing Diagram

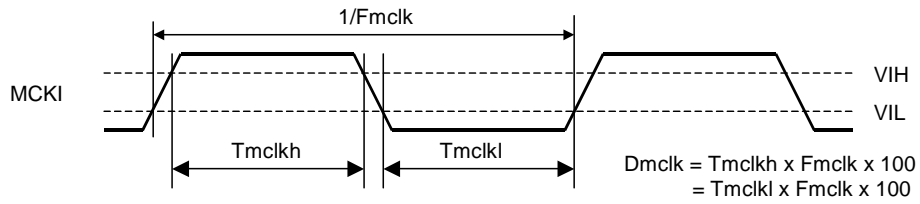

Figure 2. Master Clock Timing

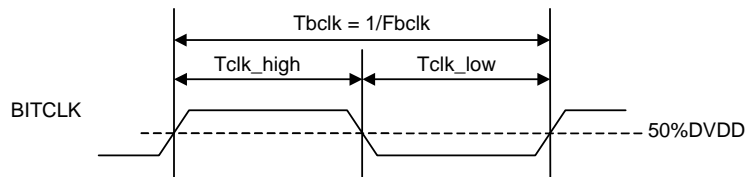

Figure 3. BITCLK Timing

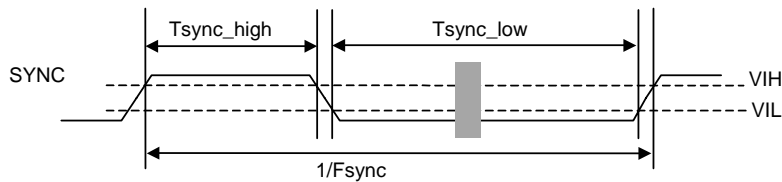

Figure 4. SYNC Timing

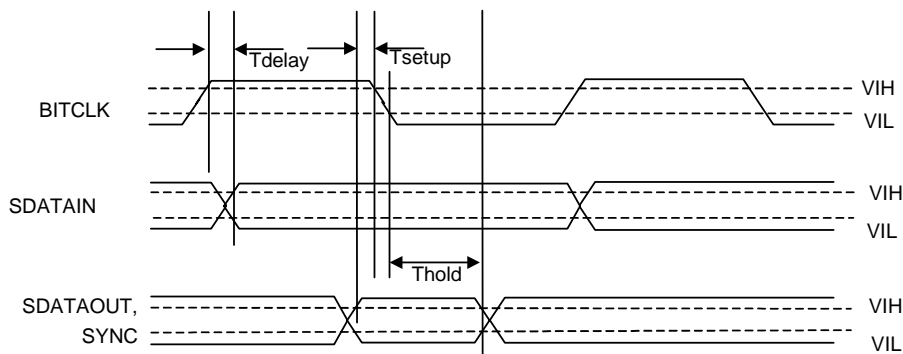

Figure 5. Setup and Hold Timing

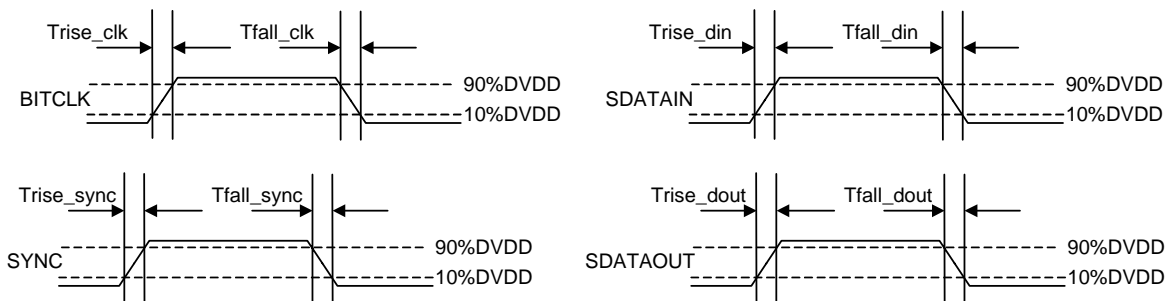

Figure 6. Signal Rise and Fall Times
 (25pF external load; between 10% DVDD and 90% DVDD)

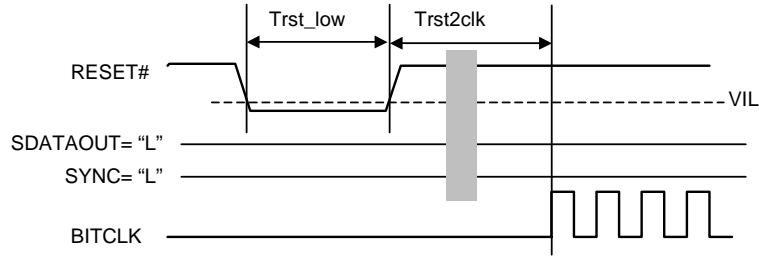

Figure 7. Cold Reset Timing

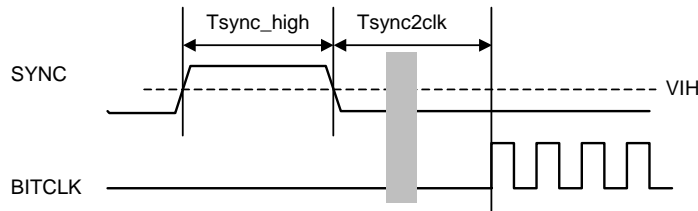

Figure 8. Warm Reset Timing

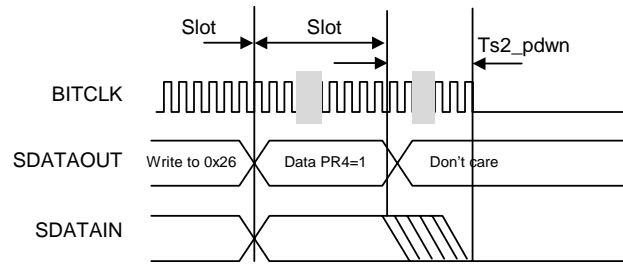

Figure 9. AC-link Low Power Mode Timing

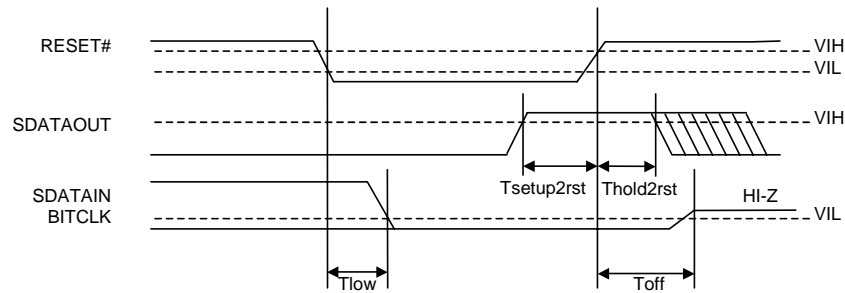

Figure 10. Activate Test Mode Timing

OPERATION OVERVIEW

■ **Master Clock Source**

The AK4651 requires a master clock (MCLK). This master clock is input to the AK4651 by the following three methods:

- (1) Connect a X'tal oscillator between XTI and XTO pins.
- (2) Input an external CMOS-level clock to the XTI pin.
- (3) Input an external clock whose amplitude is greater than 50%DVDD to the XTI pin with AC coupling.

When using a X'tal oscillator, there should be capacitors between XTI/XTO pins and DVSS (Figure 11).

Master Clock	Status	PR5 bit	MCKPD bit
X'tal Oscillator (Figure 11) (PLL1 pin = "L")	Oscillator ON	0	0
	Oscillator OFF	1	1
External Clock Direct Input (Figure 12) (PLL1 pin = "L")	Clock is input to MCKI pin.	0	0
	MCKI pin is fixed to "L".	1	0/1
	MCKI pin is fixed to "H".	1	0
	MCKI pin is Hi-Z.	1	1
External Clock Direct Input (Figure 13) (PLL1 pin = "H")	Clock is input to MCKI pin.	0	0
	MCKI pin is fixed to "L".	0	0/1
	MCKI pin is fixed to "H".	0	0
	MCKI pin is Hi-Z.	0	1
AC Coupling Input (Figure 14) (PLL1 pin = "L")	Clock is input to MCKI pin.	0	0
	Clock isn't input to MCKI pin.	1	1

Table 1. Master Clock Status by PR5 bit and MCKPD bit

(1) X'tal Oscillator (PLL1 pin = "L")

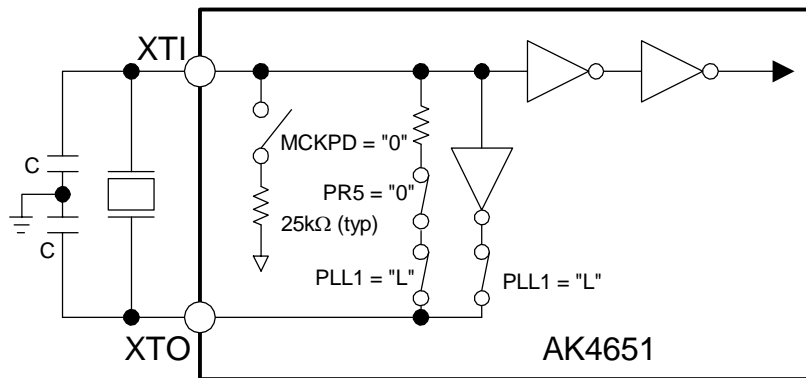

Figure 11. X'tal mode

Note 33. The capacitor values depend on the X'tal oscillator used. (C : typ. 10 ~ 30pF)

(2) External Clock Direct Input

(2-1) PLL1 pin = "L"

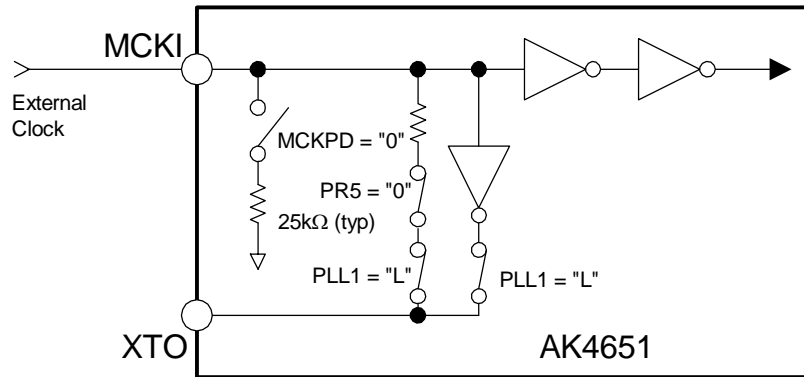

Figure 12. External Clock mode (PLL1 pin = "L", Input : CMOS Level)
 Note 34. This clock level must not exceed DVDD level.

(2-2) PLL1 pin = "H"

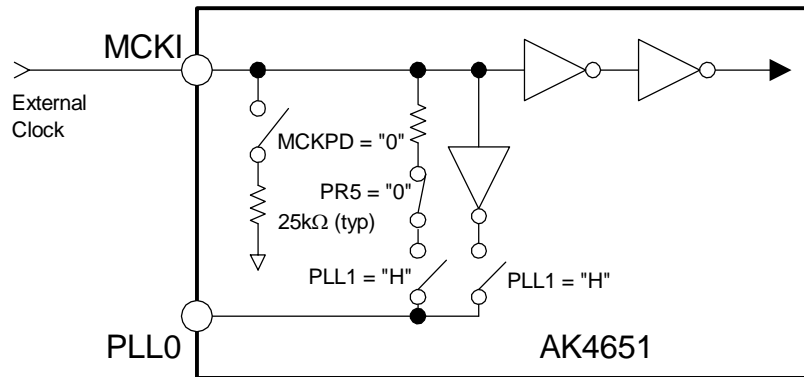

Figure 13. External Clock mode (PLL1 pin = "H", Input : CMOS Level)
 Note 35. This clock level must not exceed DVDD level.

(3) AC Coupling Input (PLL1 pin = "L")

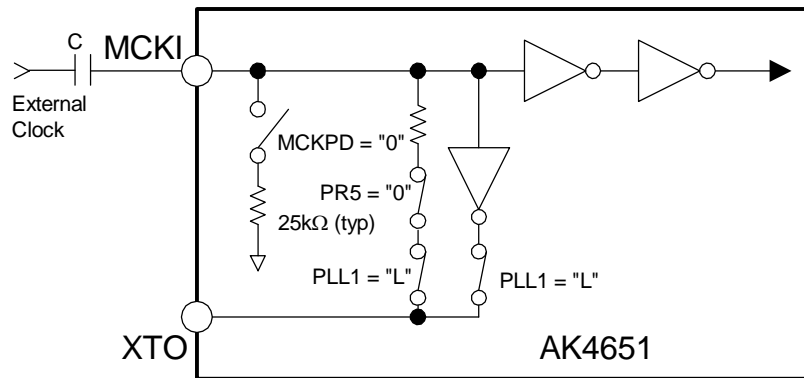

Figure 14. External Clock mode (Input : $\geq 50\%DVDD$)
 Note 36. This clock level must not exceed DVDD level. (C : 0.1 μ F)

■ System Clock

A fully integrated analog phase locked loop (PLL) generates a clock that is selected by the PLL1-0 pins (Table 2).

When the external master clock is used, the PLL should be powered-up after the external master clock is input. It takes 0.5ms(typ) for X'tal oscillator to be stable after PR5 bit = "0" which depends on the X'tal. The PLL needs 9ms lock time, whenever the sampling frequency changes or the PLL is powered-up (VRA bit = "0" → "1").

When the clock input to MCKI pin stops during normal operation of AC-Link (PR4 = PR5 = "0"), the internal PLL continues to oscillate (a few MHz), and BITCLK output goes to "L" (see Table 3).

MCLK and SYNC must be present whenever the ADC or DAC is operating (PR0 = PR1 = PR3 = PR4 = PR5 = "0"). If these clocks are not provided, the AK4651 may draw excess current due to its use of internal dynamically refreshed logic. If the external clocks are not present, the ADC and DAC must be placed in the power-down mode by setting PR0-6 bits.

PLL1	PLL0	MCKI
L	L	24.576MHz
	H	Reserved
H	L	3.6864MHz
	H	12MHz

Table 2. MCKI Input Frequency

	Power up	Power down	PLL Unlock
MCKI pin	Frequency set by PLL1-0 pins (Refer to Table 2)	Refer to Table 1	Frequency set by PLL1-0 pins (Refer to Table 2)
BITCLK pin	12.288MHz Output	"L"	"L"
SYNC pin	Input	Fixed to "L" or "H" externally	Input or Fixed to "L" or "H" externally

Table 3. Clock Operation

■ Audio Sample Rate

Sample Rate for DAC and ADC is controlled by register 2CH and 32H, respectively. 16bit data in D15(MSB) to D0 show unsigned value from 0 to 65535, representing the exact sampling frequency in Hz. These sample rate setting is done at VRA bit = "1" of Extended Audio Status and Control Register(2Ah).

Sample Rate (kHz)	Data in D15 – D0
8.0	1F40H
11.025	2B11H
16.0	3E80H
22.05	5622H
24.0	5DC0H
32.0	7D00H
44.1	AC44H
48.0	BB80H

Table 4. Audio Sample Rate

The AK4651 supports these discrete frequencies. When any other codes is written in this register, the AK4651 operates at the sampling rate rounded to the closest one in Table 4 by decoding only D15-12 bits. If D15-12 = 5H, the AK4651 operates at 22.05kHz or 24kHz when D11 = "0" or "1", respectively (Table 5).

D15 – D12	D11	Sample Rate (kHz)
0H,1H	x	8.0
2H	x	11.025
3H	x	16.0
4H	x	22.05
5H	0	22.05
	1	24.0
6H	x	24.0
7H,8H	x	32.0
9H,AH	x	44.1
BH-FH	x	48.0

Table 5. Audio Sample Rate (x: Don't care)

At VRA bit = "0", 2CH and 32H are fixed to "BB80H" and cannot be written. When VRA bit is set to "0", 2CH and 32H register are set to "BB80H" automatically.

And the change of sample rate will be executed on the fly.

■ Power Management

Power management of each block is controlled via 26H and 60H register.

	PR0 = "1"	PR1 = "1"	PR2 = "1"	PR3 = "1"	PR4 = "1"	PR5 = "1"	PR6 = "1"
ADC	PD	PU	PU	PD	PD	PD	PU
DAC	PU	PD	PU	PD	PD	PD	PU
VCM	PU	PU	PU	PD	PU	PU	PU
XTL	PU	PU	PU	PU	PU	PD	PU
PLL	VRA	VRA	VRA	PD	VRA	PD	VRA
AC-Link	PU	PU	PU	PU(Note 37)	PD	PD	PU
HP	PMHPL/R	PMHPL/R	PD	PD	PMHPL/R	PMHPL/R	PD
SPK	PMSPK	PMSPK	PD	PD	PMSPK	PMSPK	PMSPK
MIC	PMMIC	PMMIC	PD	PD	PMMIC	PMMIC	PMMIC
Line In	PMLIN	PMLIN	PD	PD	PMLIN	PMLIN	PMLIN
AUXIN	PMAUX	PMAUX	PD	PD	PMAUX	PMAUX	PMAUX
Mono Out	PMMO	PMMO	PD	PD	PMMO	PMMO	PMMO
BEEP	PMBPM	PMBPM	PD	PD	PMBPM	PMBPM	PMBPM

Table 6. Power Management

PD: Power Down

PU: Power Up

PM*: depends on each PM bit.

VRA

VRA bit = "1": PLL Power Up

VRA bit = "0": PLL Power Down

Note 37. When PLL1 pin = "H"(MCKI=3.6864MHz or 12MHz), AC-Link is powered-down by PR3 bit = "1".

■ Digital High Pass Filter

The ADC has a digital high pass filter for DC offset cancellation. The cut-off frequency of the HPF is 1.0Hz (@fs=48kHz) and scales with sampling rate (fs).

■ MIC Input

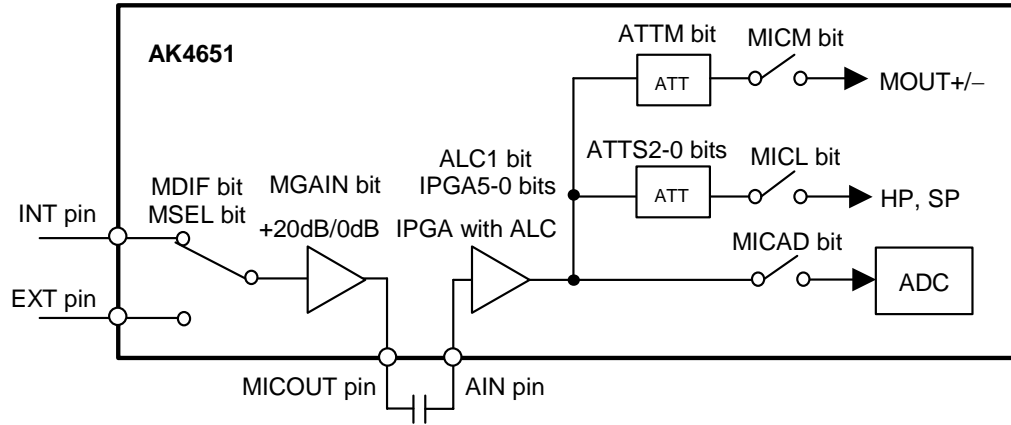

Figure 15. Microphone Input

The AK4651 has the following functions for Mic Input.

- (1) 2 Inputs Selector. The switch configure is controlled by MDIF and MSEL bits (Table 9).
- (2) 1st MIC Amplifier with +20dB gain, The gain can be selected ON/OFF by MGAIN bit (Table 10).
- (3) IPGA with ALC. This volume is controlled by IPGA5-0 bits as Table 14.
- (4) Attenuator for stereo mixer. The volume is controlled by ATTS2-0 bits as Table 7.
- (5) Attenuator for mono mixer. The attenuator level is 4dB and the ON/OFF is controlled by ATTM bit (Table 8).

ATTS2-0	Attenuation	STEP
0H	-6dB	3dB
1H	-9dB	
2H	-12dB	
3H	-15dB	
4H	-18dB	
5H	-21dB	
6H	-24dB	
7H	-27dB	

Default

Table 7. Attenuator Table (IPGA → Stereo Mixer)

ATTM	Attenuation
0	0dB
1	-4dB

Default

Table 8. Attenuator Table (IPGA → Mono Mixer)

■ MIC Input Selector

AK4651 has mic input selector in front of mic amp. MSEL bit selects internal or external mic (Figure 16). When MDIF bit = “1”, INT and EXT pins become MIC- and MIC+ pins, respectively, and differential input is available (Figure 17).

MDIF bit	MSEL bit	Selector	
0	0	INT	Default
	1	EXT	
1	x	Differential	

Table 9. MIC Input Selector (x: Don't care)

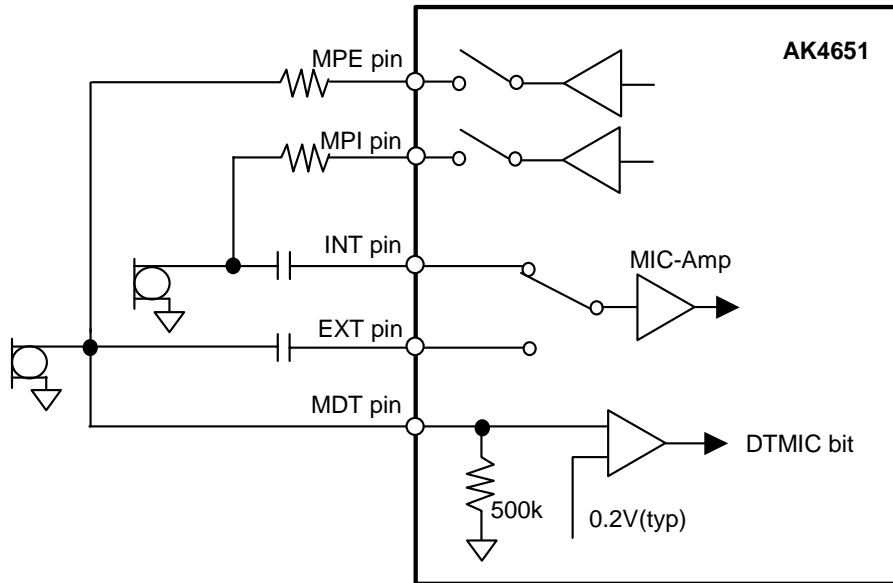

Figure 16. MIC Input (MDIF bit = “0”: Single-ended Input)

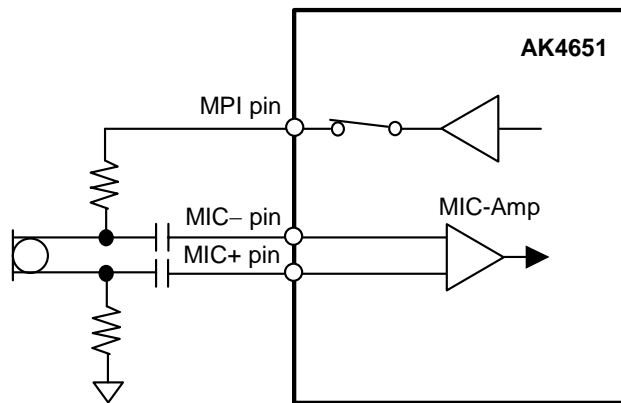

Figure 17. MIC Input (MDIF bit = “1”: Differential Input)

Note 38. In case of differential input, MGAIN bit should be set to “1”.

Maximum input voltage of each input pin is $|(MIC+) - (MIC-)| = 0.198V_{pp}(typ) @ AVDD=3.3V$.

■ MIC Gain Amplifier

The AK4651 has a Gain Amplifier for Microphone input. The gain is 0dB or +20dB, selected by the MGAIN bit. The typical input impedance is 30kΩ.

MGAIN bit	Input Gain	Default
0	0dB	
1	+20dB	

Table 10. MIC Input Gain

■ MIC Power

The MPI and MPE pins supply power for the Microphone. These output voltages are 2.2V (typ) and load resistance is 2kΩ (min). MPWRI and MPWRE bits control output from MPI and MPE pins, respectively. When LNMP bit = "1", MPE pin becomes LIN pin.

PMMIC bit	MPWRI bit	MPI pin	Default
0	x	Hi-Z	
1	0	Hi-Z	
	1	Output	

Table 11. Internal Microphone Power Supply (x: Don't care)

PMMIC bit	MPWRE bit	MPE pin	Default
0	x	Hi-Z	
1	0	Hi-Z	
	1	Output	

Table 12. External Microphone Power Supply (x: Don't care)

■ MIC Detection Function

The AK4651 includes the detection function of microphone.

Example of the detection of external microphone.

- (1) MPWRE bit = "1".
- (2) MPE drives external microphone.
- (3) DTMIC bit is set by Table 13.

Input Level of MDT	DTMIC bit	External microphone
> 0.247V	1	Connect
< 0.165V	0	Disconnect

Table 13. Microphone detection result

When RNMD bit = "1", MDT pin becomes RIN pin.

■ Manual Mode

The AK4651 becomes a manual mode at ALC1 bit = “0”. The mode is used in the case shown below.

- (1) After exiting reset state, set up the registers for the ALC1 operation (ZTM1-0, LMTH and etc)
- (2) When the registers for the ALC1 operation (Limiter period, Recovery period and etc) are changed.
For example; When the change of the sampling frequency.
- (3) When IPGA is used as a manual volume.

When writing to the IPGA5-0 bits continually, the control register should be written by an interval more than zero crossing timeout.

MICMT	IPGA5-0	GAIN (dB)	STEP
0	3FH	+27.5	0.5dB
	3EH	+27.0	
	:	:	
	09H	+0.5	
	08H	+0.0	
	07H	-1.0	1.0dB
	06H	-2.0	
	:	:	
	01H	-7.0	
	00H	-8.0	
1	x	MUTE	

Default

Table 14. IPGA Volume (x: Don't care)

■ MIC-ALC Operation

The ALC (Automatic Level Control) of MIC input is done by ALC1 block when ALC1 bit is “1”.

(1) ALC1 Limiter Operation

When the ALC1 limiter is enabled, and IPGA output exceeds the ALC1 limiter detection level (LMTH bit: Table 15), the IPGA value is attenuated by the amount defined in the ALC1 limiter ATT step (LMAT1-0 bits: Table 16) automatically.

When the ZELMN bit = “1”, the timeout period is set by the LTM1-0 bits (Table 17). The operation for attenuation is done continuously until the IPGA output signal level becomes LMTH or less. If the ALC1 bit does not change into “0” after completing the attenuation, the attenuation operation repeats while the IPGA output signal level equals or exceeds LMTH.

When the ZELMN bit = “0”, the timeout period is set by the ZTM1-0 bits (Table 18). This enables the zero-crossing attenuation function so that the IPGA value is attenuated at the zero-detect points of the waveform.

LMTH	ALC1 Limiter Detection Level	ALC1 Recovery Waiting Counter Reset Level	
0	ADC Input $\geq -6.0\text{dBFS}$	$-6.0\text{dBFS} > \text{ADC Input} \geq -8.0\text{dBFS}$	Default
1	ADC Input $\geq -4.0\text{dBFS}$	$-4.0\text{dBFS} > \text{ADC Input} \geq -6.0\text{dBFS}$	

Table 15. ALC1 Limiter Detection Level / Recovery Waiting Counter Reset Level

LMAT1	LMAT0	ATT STEP	
0	0	1	Default
0	1	2	
1	0	3	
1	1	4	

Table 16. ALC1 Limiter ATT Step Setting

Note: When IPGA gain is 0dB or less, ALC1 limiter ATT step is fixed to 1 regardless as LMAT1-0 bits.

LTM1	LTM0	ALC1 Limiter Operation Period				
			8kHz	16kHz	44.1kHz	
0	0	0.5/fs	63 μs	31 μs	11 μs	Default
0	1	1/fs	125 μs	63 μs	23 μs	
1	0	2/fs	250 μs	125 μs	45 μs	
1	1	4/fs	500 μs	250 μs	91 μs	

Table 17. ALC1 Limiter Operation Period at zero crossing disable (ZELMN bit = “1”)

ZTM1	ZTM0	Zero Crossing Timeout Period				
			8kHz	16kHz	44.1kHz	
0	0	128/fs	16ms	8ms	2.9ms	Default
0	1	256/fs	32ms	16ms	5.8ms	
1	0	512/fs	64ms	32ms	11.6ms	
1	1	1024/fs	128ms	64ms	23.2ms	

Table 18. Zero Crossing Timeout Period

(2) ALC1 Recovery Operation

The ALC1 recovery refers to the amount of time that the AK4651 will allow a signal to exceed a predetermined limiting value prior to enabling the limiting function. The ALC1 recovery operation uses the WTM1-0 bits to define the wait period used after completing an ALC1 limiter operation (Table 19). If the input signal does not exceed the “ALC1 Recovery Waiting Counter Reset Level” (LMTH: Table 15), the ALC1 recovery operation starts. The IPGA value increases automatically by the recovery gain step (RGAIN bit: Table 20) with zero crossing operation (timeout is set by ZTM1-0: Table 18) during this operation up to the reference level (REF5-0 bit: Table 21). The ALC1 recovery operation is done at a period set by the WTM1-0 bits. Zero crossing is detected during WTM1-0 period, the ALC1 recovery operation waits WTM1-0 period and the next recovery operation starts.

During the ALC1 recovery operation, when input signal level exceeds the ALC1 limiter detection level (LMTH), the ALC1 recovery operation changes immediately into an ALC1 limiter operation.

In the case of

(Recovery waiting counter reset level) ≤ (IPGA Output Level) < (Limiter detection level)
 during the ALC1 recovery operation, the wait timer for the ALC1 recovery operation is reset. Therefore, in the case of
 (Recovery waiting counter reset level) > (IPGA Output Level),
 the wait timer for the ALC1 recovery operation starts.

The ALC1 operation corresponds to the impulse noise. When the impulse noise is input, the ALC1 recovery operation becomes faster than a normal recovery operation.

WTM1	WTM0	ALC1 Recovery Operation Waiting Period				Default
			8kHz	16kHz	44.1kHz	
0	0	128/fs	16ms	8ms	2.9ms	
0	1	256/fs	32ms	16ms	5.8ms	
1	0	512/fs	64ms	32ms	11.6ms	
1	1	1024/fs	128ms	64ms	23.2ms	

Table 19. ALC1 Recovery Operation Waiting Period

RGAIN	GAIN STEP	Default
0	0.5dB	
1	1.0dB	

Table 20. ALC1 Recovery Gain Step Setting

REF5-0	GAIN (dB)	STEP	Default
3DH	+26.5	0.5dB	
3CH	+26.0		
:	:		
2DH	+19.0		
:	:		
05H	+0.5		
04H	+0.0	1.0dB	
03H	-1.0		
02H	-2.0		
:	:		
01H	-7.0		
00H	-8.0		

Table 21. Setting Reference Value at ALC1 Recovery Operation

(3) Example of ALC1 Operation

Table 22 shows the examples of the ALC1 setting. In case of this examples, ALC1 operation starts from 0dB.

Register Name	Comment	fs=8kHz		fs=16kHz		fs=44.1kHz	
		Data	Operation	Data	Operation	Data	Operation
LMTH	Limiter detection Level	1	-4dBFS	1	-4dBFS	1	-4dBFS
LTM1-0	Limiter operation period at ZELMN bit = "1"	00	Don't use	00	Don't use	00	Don't use
ZELMN	Limiter zero crossing detection	0	Enable	0	Enable	0	Enable
ZTM1-0	Zero crossing timeout period	00	16ms	01	16ms	10	11.6ms
WTM1-0	Recovery waiting period *WTM1-0 bits should be the same data as ZTM1-0 bits	00	16ms	01	16ms	10	11.6ms
REF5-0	Maximum gain at recovery operation	3DH	+26.5dB	3DH	+26.5dB	3DH	+26.5dB
IPGA5-0	Gain of IPGA at ALC1 operation start	37H	0dB	37H	0dB	37H	0dB
LMAT1-0	Limiter ATT Step	00	0.5dB	00	0.5dB	00	0.5dB
RGAIN	Recovery GAIN Step	0	0.5dB	0	0.5dB	0	0.5dB
ALC1	ALC1 Enable bit	1	Enable	1	Enable	1	Enable

Table 22. Example of the ALC1 setting

The following registers should not be changed during the ALC1 operation. These bits should be changed, after the ALC1 operation is finished by ALC1 bit = "0" or PMMIC bit = "0".

- LTM1-0, LMTH, LMAT1-0, WTM1-0, ZTM1-0, RGAIN, REF5-0, ZELMN bits

IPGA gain at ALC1 operation start can be changed from the default value of IPGA5-0 bits while PMMIC bit is "1" and ALC1 bit is "0". When ALC1 bit is changed from "1" to "0", IPGA holds the last gain value set by ALC1 operation.

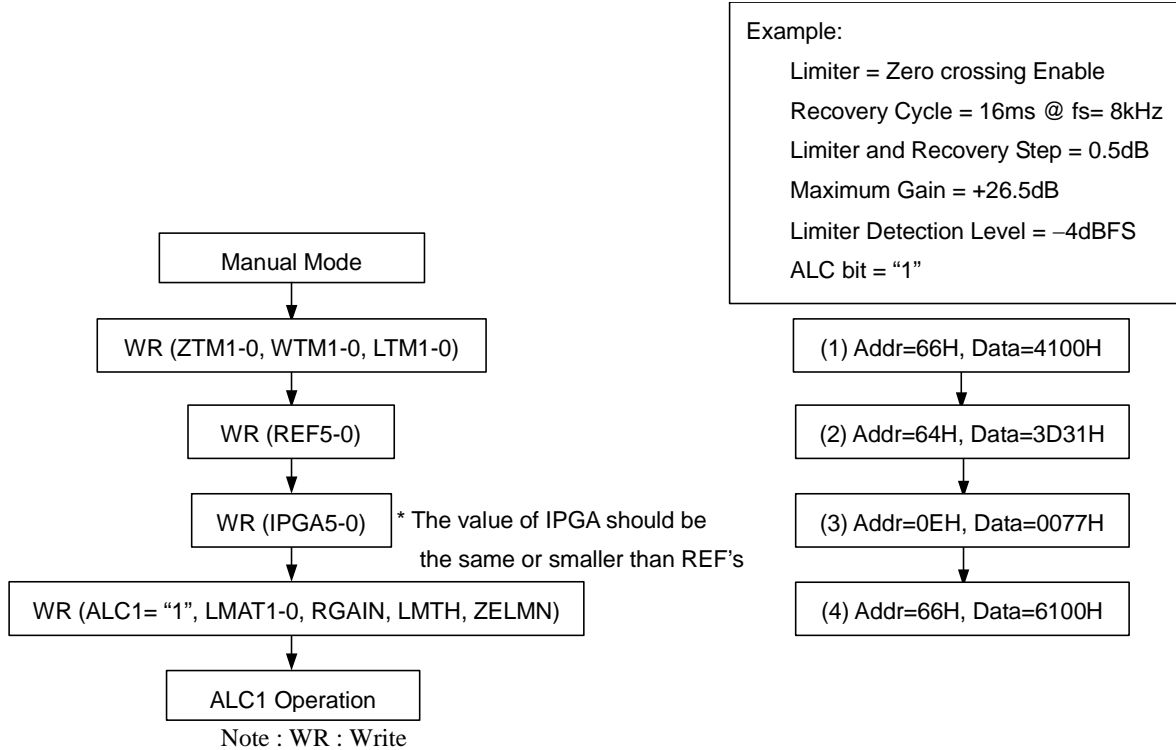

Figure 18. Registers set-up sequence at ALC1 operation

■ De-emphasis Filter

The AK4651 includes the digital de-emphasis filter ($t_c = 50/15\mu s$) by IIR filter. Setting the DEM1-0 bits enables the de-emphasis filter (Table 23).

DEM1	DEM0	Mode
0	0	44.1kHz
0	1	OFF
1	0	48kHz
1	1	32kHz

Default

Table 23. De-emphasis Control

■ Bass Boost Function

The BST1-0 bits control the amount of low frequency boost applied to the DAC output signal (Table 24). If the BST1-0 bits are set to "10" (MID Level), AC-coupling capacitor can be sized down to $47\mu F$. If the boosted signal exceeds the full scale, the analog output clips to the full scale.

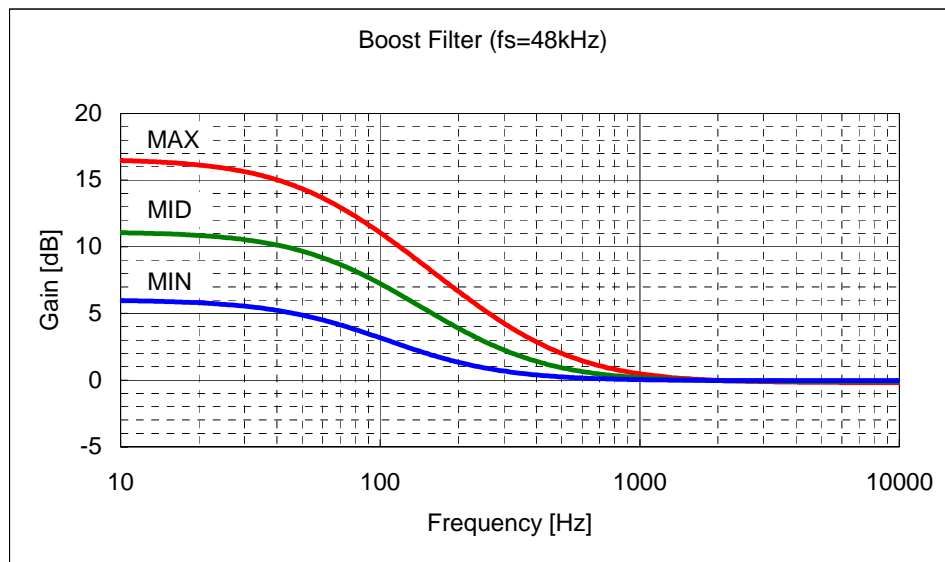

Figure 19. Bass Boost Frequency (fs=48kHz)

BST1	BST0	Mode
0	0	OFF
0	1	MIN
1	0	MID
1	1	MAX

Default

Table 24. Bass Boost Control

■ Digital Attenuator

The AK4651 has a channel-independent digital attenuator (128 levels, 0.5dB step, Mute). The attenuation level of each channel can be set by the ATTL/R6-0 bits (Table 25). When the DATTC bit = “1”, the ATTL6-0 bits control both Lch and Rch attenuation levels. When the DATTC bit = “0”, the ATTL6-0 bits control Lch level and ATTR6-0 bits control Rch level.

ATTL/R6-0	Attenuation	STEP
00H	0dB	0.5dB
01H	-0.5dB	
02H	-1.0dB	
:	:	
7DH	-62.5dB	
7EH	-63.0dB	
7FH	MUTE ($-\infty$)	

Default

Table 25. DAT Attenuation Table

The ATS bit sets the transition time between set values of ATTL/R6-0 bits as either 531/fs or 128/fs (Table 26). When ATS bit = “0”, a soft transition between the set values occurs (531 levels). It takes 531/fs (11ms@fs=48kHz) from 00H(0dB) to 7FH(MUTE).

ATS	ATT speed	
	0dB to MUTE	1 step
0	531/fs	4/fs
1	128/fs	29/fs

Default

Table 26. Transition time between set values of ATTL/R6-0 bits

■ Soft Mute

Soft mute operation is performed in the digital domain. When the SMUTE bit goes to “1”, the output signal is attenuated by $-\infty$ (“0”) during the cycle set by the TM1-0 bits (Table 27). When the SMUTE bit is returned to “0”, the mute is cancelled and the output attenuation gradually changes to 0dB during the cycle set of the TM1-0 bits. If the soft mute is cancelled within the cycle of setting the TM1-0 bits after starting the operation, the attenuation is discontinued and returned to 0dB. The soft mute is effective for changing the signal source without stopping the signal transmission (Figure 20).

The soft mute function is independent of output volume and cascade connected between both functions.

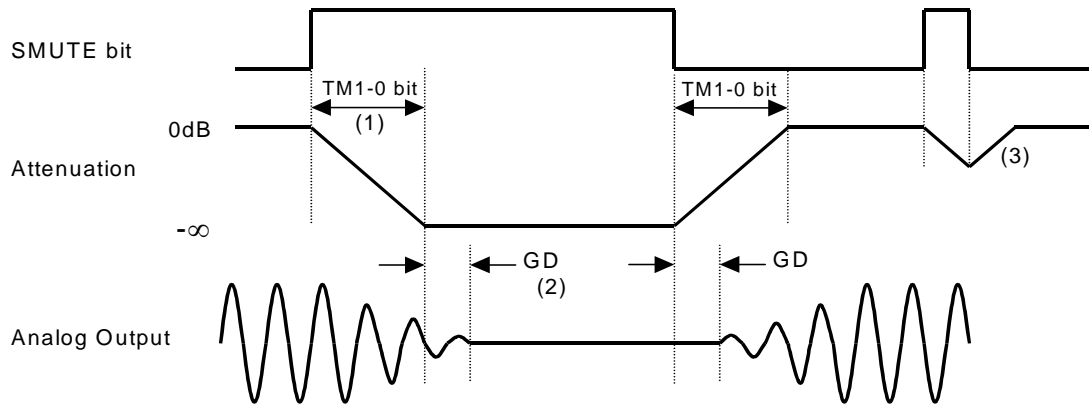

Figure 20. Soft Mute Function

Note:

- (1) The output signal is attenuated until $-\infty$ (“0”) by the cycle set by the TM1-0 bits.
- (2) Analog output corresponding to digital input has the group delay (GD).
- (3) If the soft mute is cancelled within the cycle of setting the TM1-0 bits, the attenuation is discontinued and returned to 0dB(the set value).

TM1	TM0	Cycle	
0	0	1024/fs	Default
0	1	512/fs	
1	0	256/fs	
1	1	128/fs	

Table 27. Soft Mute Time Setting

■ AUX Input

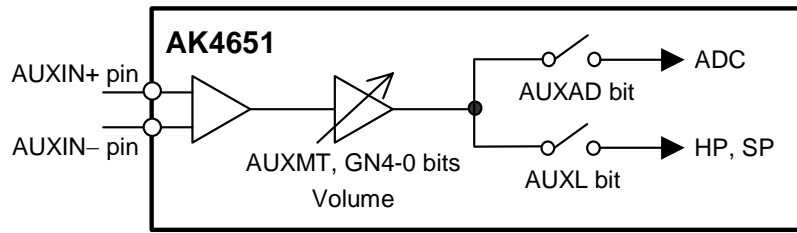

Figure 21. AUX Input

AUX input is a differential input. The AK4651 has a volume for AUX Input. This Volume is controlled by GN3-0 bits as shown in Table 28. The switching noise occurs when GN3-0 bits are changed.

AUXMT	GN4-0	GAIN (dB)	STEP
0	00H	+12.0	1.5dB
	01H	+10.5	
	02H	+9.0	
	:	:	
	08H	+0.0	
	:	:	
	1EH	-33.0	
1FH	-34.5		
1	x	MUTE	

Default

Table 28. AUX Input Gain Setting (x: Don't care)

■ Stereo Line Input

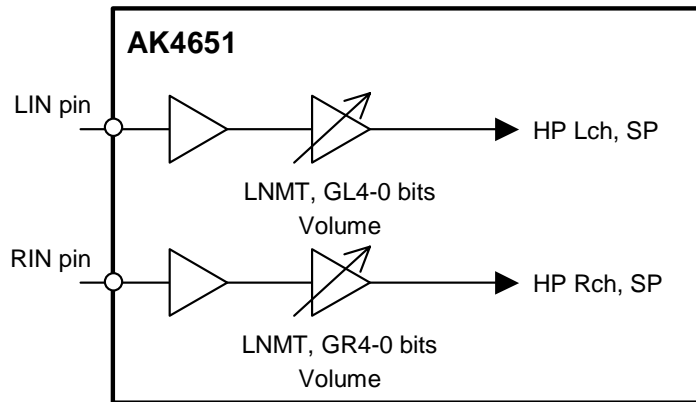

Figure 22. Stereo Line Input

When LNMP bit is “1”, MPE pin becomes LIN pin. When RNMD bit is “1”, MDT pin becomes RIN pin. LIN/RIN is single-ended input. The AK4651 has a volume for Stereo Line Input. This Volume is controlled by GL4-0 and GR4-0 bits as shown in Table 28. The switching noise occurs when GL4-0 or GR4-0 bits are changed.

LNMT	GL/GR4-0	GAIN (dB)	STEP
0	00H	+12.0	1.5dB
	01H	+10.5	
	02H	+9.0	
	:	:	
	08H	+0.0	
	:	:	
	1EH	-33.0	
1FH	-34.5		
1	x	MUTE	

Default

Table 29. Stereo Line Input Volume Setting (x: Don't care)

■ BEEP Input

When the PMBPM bit is set to “1”, mono beep input is powered up. And when the BPMHP bit is set to “1”, the signal from the BEEP pin is input to Headphone-amp. When the BPMSP bit is set to “1”, the signal from the BEEP pin is input to Speaker output. The external resistors R_i adjust the signal level of each BEEP input that are mixed to Headphone and Speaker outputs.

The signal from the BEEP pin is mixed to the Headphone-amp through a -20dB gain stage. The signal from the BEEP pin is mixed to the Speaker-amp without gain. The internal feedback resistance is $20\text{k}\Omega \pm 30\%$. When BPMT bit is “1”, BEEP input is muted.

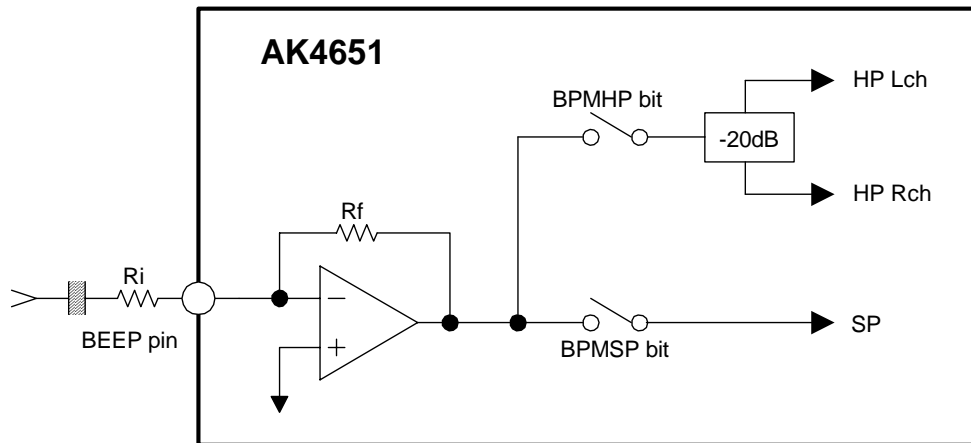

Figure 23. Block Diagram of BEEP pins
($R_f = 20\text{k}\Omega \pm 30\%$)

■ MONO LINE OUTPUT (MOUT+ and MOUT- pins)

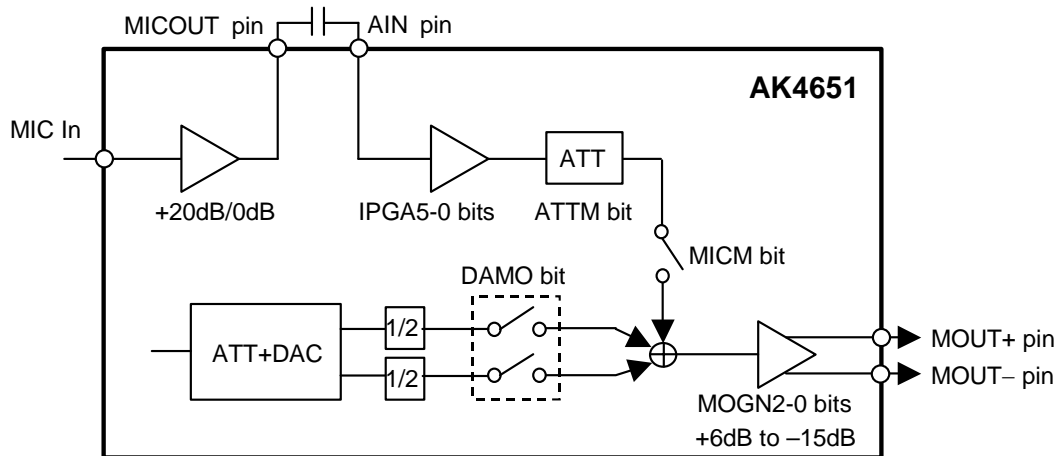

Figure 24. Mono Output

Mono mixer mixes signals from MIC In, DAC Lch and Rch. This mixed signal is output from the MOUT+ and MOUT- pins, creating a differential output. Either the MOUT+ or MOUT- pin can be also used as single-ended output. Load resistance is 20kΩ(min). When PMMO bit is “0”, mono output is powered-down and MOUT+/- pins become Hi-Z.

PMMO	MOMT	Mode	MOUT+/MOUT- pin	
0	x	Power-down	Hi-Z	Default
1	1	Mute	VCOM	
	0	Normal operation	Normal operation	

Table 30. Mono Output Setting

Volume of path from DAC is controlled by ATTL7-0 and ATTR7-0 bits (Table 25). Volume of path from IPGA is controlled by ATTM bit (Table 8). Mono output amp has +6dB to -15dB gain that are set by the MOGN2-0 bits (Table 31).

MOGN2-0	GAIN (dB)	STEP	
0H	+6.0	3dB	Default
1H	+3.0		
2H	+0.0		
3H	-3.0		
4H	-6.0		
5H	-9.0		
6H	-12.0		
7H	-15.0		

Table 31. Mono Output Gain Control

■ Headphone Output

Power supply voltage for the Headphone-amp is supplied from the HVDD pin and centered on the MUTET voltage. The Headphone-amp output load resistance is min.16Ω. When the HPMT bit is “1” at PMHPL=PMHPR= “1”, the common voltage rises to 0.44 x AVDD. When the HPMT bit is “1”, the common voltage of Headphone-amp falls and the outputs (HPL and HPR pins) go to HVSS.

A capacitor between the MUTET pin and ground reduces pop noise at power-up/down. It is recommended that the capacitor with small variation of capacitance and low ESR (Equivalent Series Resistance) over all temperature range, since the rise and fall time in Table 32 depend on the capacitance and ESR of the external capacitor at MUTET pin.

t_r : Rise Time up to 0.44 x AVDD	100k x C (typ)
t_f : Fall Time down to 0V	200k x C (typ)

Table 32. Headphone-Amp Rise/Fall Time

[Example]: A capacitor between the MUTET pin and ground = 1.0μF:

Rise Time up to 0.44 x AVDD: $t_r = 100k\Omega \times 1\mu F = 100ms(\text{typ})$

Fall Time down to 0V: $t_f = 200k\Omega \times 1\mu F = 200ms(\text{typ})$

When PMHPL and PMHPR bits are “0”, the Headphone-amp is powered-down, and the outputs (HPL and HPR pins) go to HVSS.

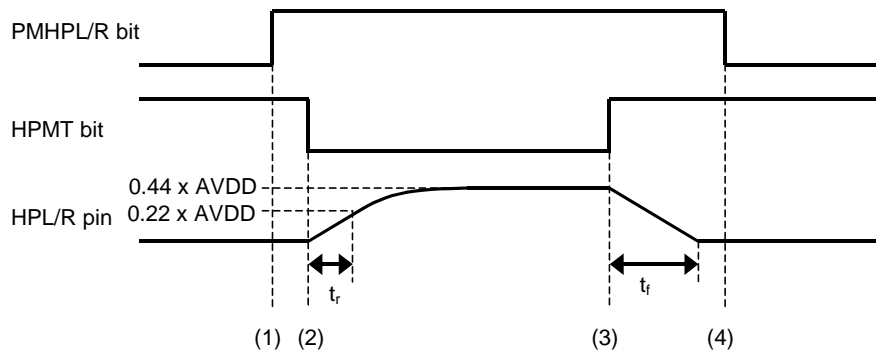

Figure 25. Power-up/Power-down Timing for Headphone-amp

- (1) Headphone-amp power-up (PMHPL and PMHPR bits = “1”). The outputs are still HVSS.
- (2) Headphone-amp common voltage rises up (HPMT bit = “0”). Common voltage of Headphone-amp is rising. This rise time depends on the capacitor value connected with the MUTET pin. The rise time up to 0.44 x AVDD is $t_r = 100k \times C(\text{typ})$ when the capacitor value on MUTET pin is “C”.
- (3) Headphone-amp common voltage falls down (HPMT bit = “1”). Common voltage of Headphone-amp is falling to HVSS. This fall time depends on the capacitor value connected with the MUTET pin. The fall time down to 0V is $t_f = 200k \times C(\text{typ})$ when the capacitor value on MUTET pin is “C”.
- (4) Headphone-amp power-down (PMHPL, PMHPR bits = “0”). The outputs are HVSS. If the power supply is switched off or Headphone-amp is powered-down before the common voltage goes to HVSS, some pop noise occurs.

The cut-off frequency of Headphone-amp output depends on the external resistor and capacitor used. Table 33 shows the cut off frequency and the output power for various resistor/capacitor combinations. The Headphone impedance R_L is 16Ω . Output powers are shown at $HVDD = 2.7, 3.0$ and $3.3V$. The output voltage of Headphone is $0.6 \times AVDD$ (Vpp).

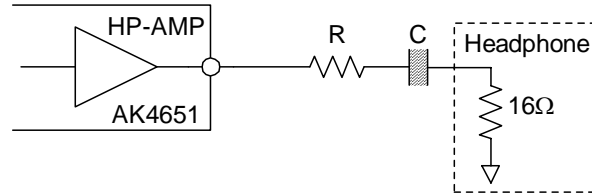

Figure 26. External Circuit Example of Headphone

R [Ω]	C [μ F]	fc [Hz] BOOST=OFF	fc [Hz] BOOST=MIN	Output Power [mW]		
				2.7V	3.0V	3.3V
0	220	45.2	17	27.9	34.5	41.7
	100	99.5	42			
6.8	100	69.8	28	13.7	17.0	20.5
	47	148.5	74			
16	100	49.7	19	7.0	8.6	10.4
	47	105.8	46			

Table 33. Relationship of external circuit, output power and frequency response

■ Headphone Jack Detection

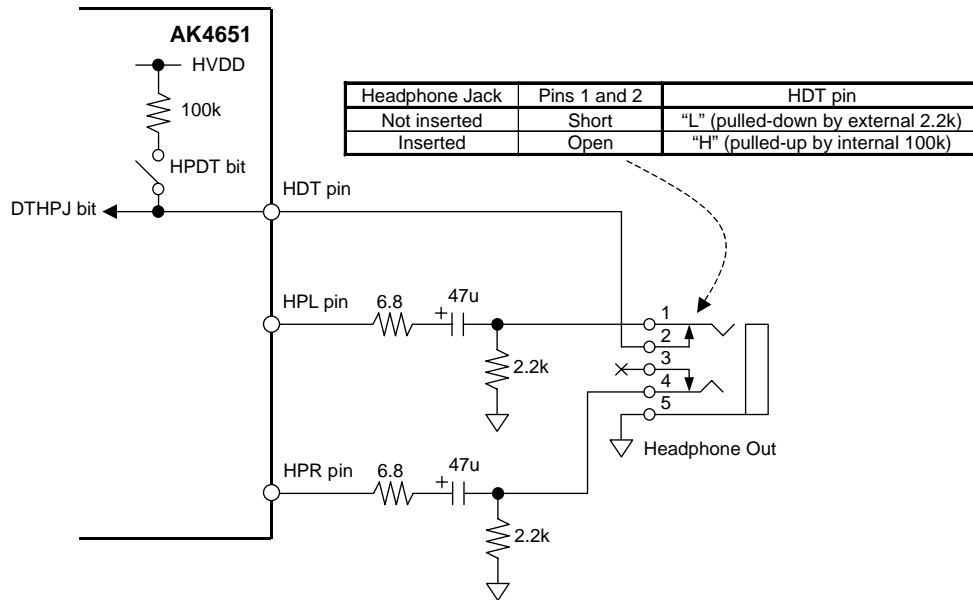

Figure 27. Headphone Jack Detection

Headphone jack detection sequence example:

- (1) HPDT bit = "1".
- (2) HDT pin is pulled-up to HVDD by 100kΩ.
- (3) DTHPJ bit indicates whether headphone jack is inserted or not.

Headphone jack detection result is reported to DTHPJ bit (Table 34). If HPINT bit is "1", INTN pin becomes "L" when headphone jack is detected.

Input Level of HDT	DTHPJ bit	Headphone Jack
< 0.3 x HVDD	0	Not inserted
> 0.7 x HVDD	1	Inserted

Table 34. Headphone Jack Detection Result

When ATSW bit is "1" at PMHPL=PMHPR=PMSPK= "1" and HPMT=SPPS= "0", Headphone-amp and Speaker-amp are automatically powered-up/down according to headphone jack detection result (Table 35, Table 36).

DTHPJ	PMHPL PMHPR	HPMT	HP-Amp
0	x	x	Power Down
1	0	1	Power Down
	1	0	Power UP

Table 35. Headphone-amp automatic power-down (ATSW bit = "1")

DTHPJ	PMSPK	SPPS	SPK-Amp
0	0	X	Power Down
	1	1	Power Save
		0	Power UP
1	0	X	Power Down
	1	X	Power Save

Table 36. Speaker-amp automatic power-save (ATSW bit = "1")

■ **Speaker Output**

Mono signal [(L+R)/2] converted from stereo DAC output and BEEP input signal can be output via Speaker-amp which output is BTL. DAC output signal can be input to the Speaker-amp via the ALC2 circuit. This Speaker-amp can output a maximum of 300mW@ALC2 bit = “0” and 190mW@ALC2 bit = “1”.

ALC2	Po	
0	300mW	Default
1	190mW	

Table 37. Speaker-Amp Output Power

Speaker blocks (MOUT2, ALC2 and Speaker-amp) can be powered-up/down by controlling the PMSPK bit. When the PMSPK bit is “0”, the MOUT2, SPP and SPN pins are placed in a Hi-Z state.

When the SPPS bit is “1”, the Speaker-amp is power-save-mode. In this mode, the SPP pin is placed in a Hi-Z state and the SPN pin goes to HVDD/2 voltage. And then the Speaker output gradually changes to the HVDD/2 voltage and this mode can reduce pop noise at power-up. When the AK4651 is powered-down, pop noise can be also reduced in power-save-mode.

PMSPK	SPPS	Mode	SPP pin	SPN pin	
0	x	Power-down	Hi-Z	Hi-Z	Default
1	1	Power-save	Hi-Z	HVDD/2	
	0	Normal operation	Normal operation	Normal operation	

Table 38. Speaker Output Setting

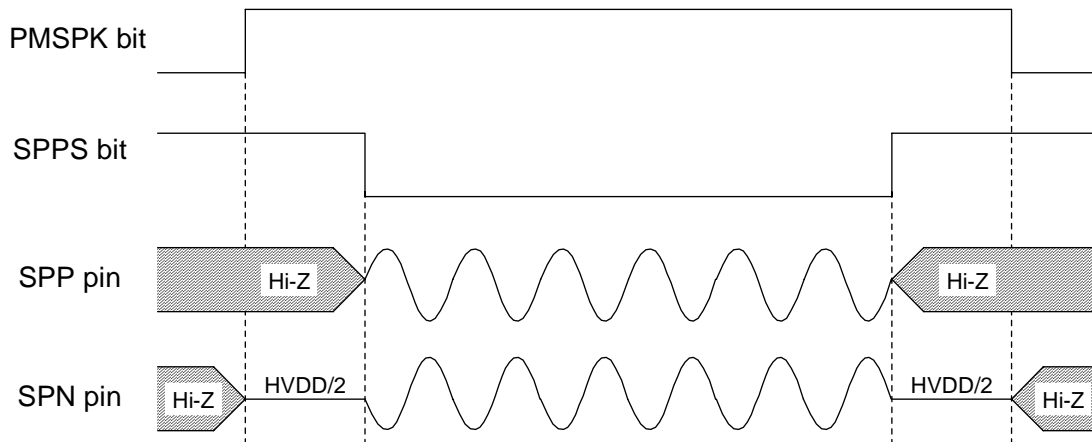

Figure 28. Power-up/Power-down Timing for Speaker-amp

■ **Mono Output (MOUT2 pin)**

The mixed Lch/Rch signal of DAC is output from the MOUT2 pin. When the MO2 bit is “0”, this output is OFF and the MOUT2 pin is forced to VCOM voltage. The load impedance is 10kΩ (min.). When the PMSPK bit is “0”, the Speaker-amp enters power-down-mode and the output is placed in a Hi-Z state.

■ ALC2 Operation

Input resistance of the ALC2 (MIN pin) is 24kΩ (typ) and centered around VCOM voltage. Figure 29 shows input-output relationship at ALC2 operation (0dBV=1Vrms =2.828Vpp).

The limiter detection level is proportional to HVDD. The output level is limited by the ALC2 circuit when the Speaker-amp output level exceeds +1.8dBV@HVDD=3.3V. When a continuous signal of +1.8dBV or greater is input to the ALC2 circuit, the output level is attenuated by ALC2 operation. The change period of the ALC2 limiter operation is set by the ROTM bit and the attenuation level is 0.5dB/step (Table 39).

When the Speaker-amp output level is equal to or lower than -2dBV@HVDD=3.3V, the ALC2 recovery operation starts. The ALC2 recovery operation uses zero crossings and gains of 1dB/step. The ALC2 recovery operation is done until the output level of the Speaker-amp goes to -2dBV@HVDD=3.3V. The ALC2 maximum gain is +18dB. The ROTM bit sets the ALC2 recovery operation period (Table 39).

When the output signal is between +1.8dBV and -2dBV, the ALC2 limiter or recovery operations are not done.

When the PMSPK bit changes from “0” to “1”, the initialization cycle (2048/fs = 46.4ms @fs=44.1kHz at ROTM bit = “0”, 512/fs = 11.6ms @fs=44.1kHz at the ROTM bit = “1”) starts. This fs value is set by Addr=32H (ADC sampling frequency). The ALC2 is disabled during the initialization cycle and the ALC2 starts after completing the initialization cycle.

Parameter		ALC2 Limiter operation	ALC2 Recovery operation
Operation Start Level		+1.8dBV	-2dBV
Period	ROTM bit = “0”	2/fs = 45μs@fs=44.1kHz	2048/fs = 46.4ms@fs=44.1kHz
	ROTM bit = “1”	2/fs = 181μs@fs=11.025kHz	512/fs = 46.4ms@fs=11.025kHz
Zero-crossing Detection		Disabled	Enabled (Timeout = 2048/fs)
ATT/GAIN		0.5dB step	1dB step

Table 39. Limiter /Recovery of ALC2 at HVDD=3.3V

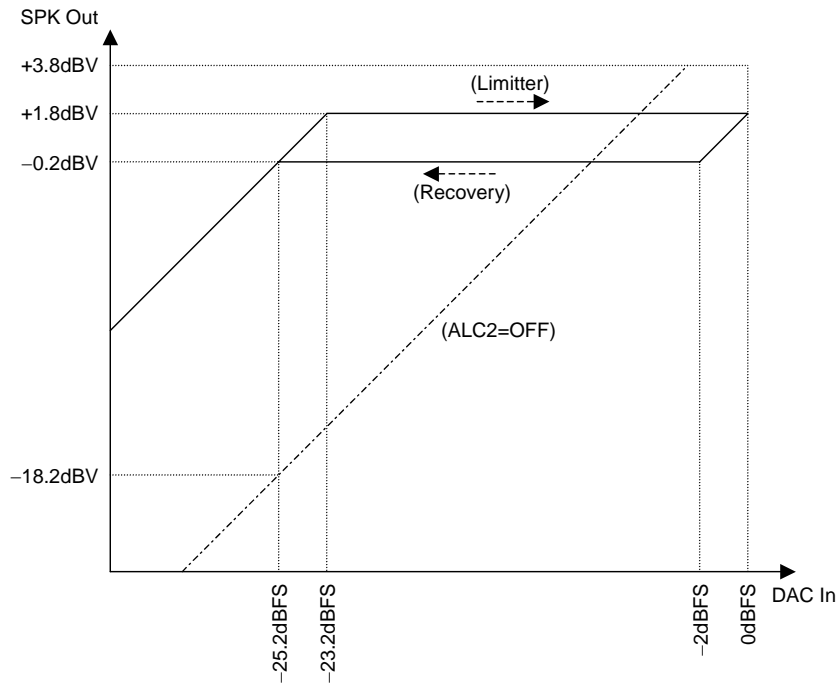

Figure 29. DAC input – Speaker output relationship (HVDD=3.3V, ALC2 bit = “1”)

■ Example of Path

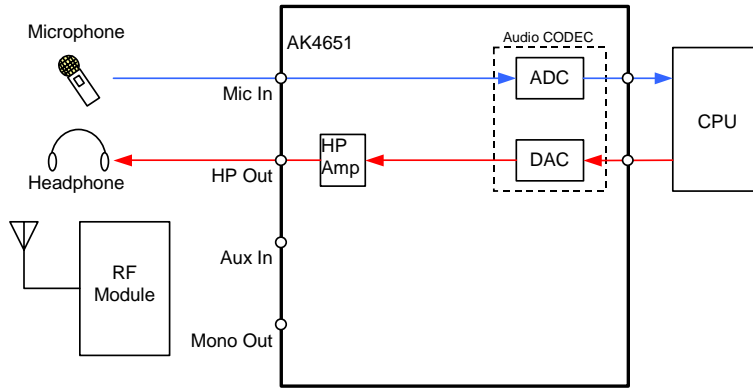

Figure 30. MIC recording & Headphone playback

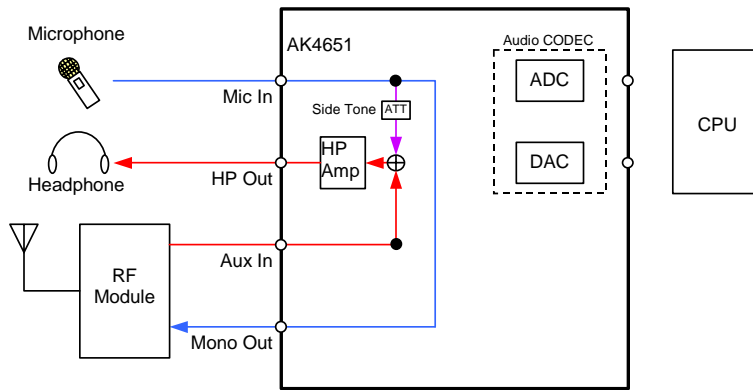

Figure 31. Phone

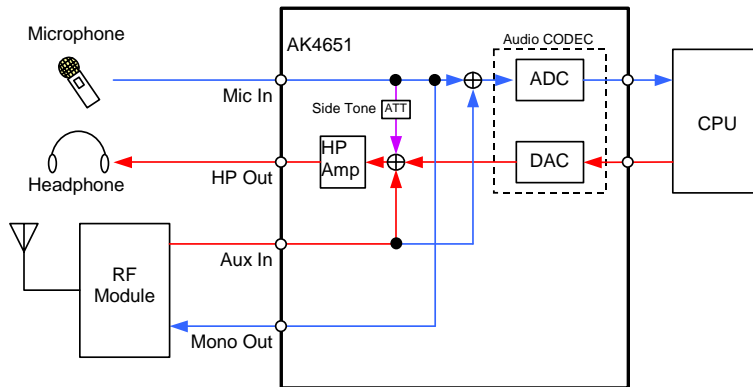

Figure 32. Recording/Playback & Phone

■ AC-Link Power-down

The AK4651 controls the AC-link power-up/down by PR4 and PR5 bits. When PR4 bit is “1”, BITCLK and SDATAIN go to “L”, but X’tal oscillator still operates. When PR5 bit is “1”, BITCLK and SDATAIN go to “L”, and X’tal oscillator is powered-down. PLL power-up/down is controlled by VRA bit.

	BITCLK/SDATAIN output	X’tal oscillator	PLL
PR4 bit = “1”	Stop	Normal operation	Power Down
PR5 bit = “1”	Stop	Stop	Power Down
VRAbit = “0”	Output	Normal operation	Power Down

Table 40. AC-Link Power-down

■ Method using Slot 12 of SDATAIN

When SLOT bit is “1”, headphone jack detection results are output via slot 12 of SDATAIN.

Bit 1: Headphone jack detection result

■ Connection with Digital AC '97 Controller

The AK4651 communicates with its companion AC '97 controller via a digital serial link, "AC-link". All digital audio streams, and command/status information are communicated over this point to point serial interconnect. A breakout of the signals connecting the two is shown in the following figure.

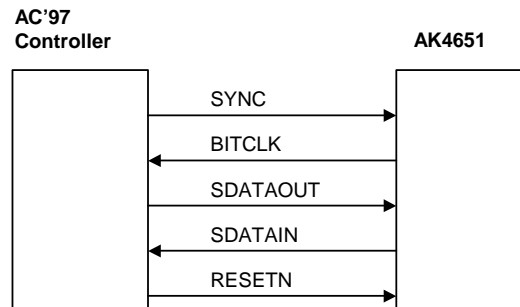

Figure 33. Connection between AK4651 and AC '97 controller

RESETN	(Input)	: Control signal to reset the AK4651
BITCLK	(Output)	: 12.288MHz clock output from the AK4651
SYNC	(Input)	: Control signal to synchronize the AK4651 with AC'97 controller
SDATAIN	(Output)	: Data signal input to the controller (output from the AK4651)
SDATAOUT	(Input)	: Data signal output to the controller (input from the AK4651)

■ Digital Interface

The AK4651 incorporates a 5 pin digital serial interface that links it to the AC '97 controller. AC-link is a bi-directional, fixed rate(48kHz), serial PCM digital stream. It handles input/output audio streams as well as control register accesses employing a time division multiplexed (TDM) scheme. The AC-link architecture divides each audio frame into 12 outgoing and 12 incoming data streams, each with 20-bit sample resolution. DAC and ADC resolution of the AK4651 is 16 bit resolution. The data streams currently defined by the AC '97 specification include:

- **PCM Playback** **2 output slots**
2 channel composite PCM output stream
- **PCM Record data** **2 input slots**
1 channel composite PCM input stream
- **Control** **2 output slots**
Control register write port
- **Status** **2 input slots**
Control register read port

SYNC, fixed at 48kHz, is derived by dividing down the serial bit clock (BITCLK) output from the AK4651. BITCLK, fixed at 12.288 MHz, provides the necessary clocking granularity to support 12, 20-bit outgoing and incoming time slots. AC-link serial data is transitioned on each rising edge of BITCLK. The receiver of AC-link data, the AK4651 for outgoing data and AC '97 controller for incoming data, samples each serial bit on the falling edges of BITCLK.

The AC-link protocol provides for a special 16-bit slot (Slot 0) wherein each bit conveys a valid tag for its corresponding time slot within the current audio frame. A "1" in a given bit position of slot 0 indicates that the corresponding time slot within the current audio frame has been assigned to a data stream, and contains valid data. If a slot is "Tagged" invalid, it is the responsibility of the source of the data (the AK4651 for the input stream, AC '97 controller for the output stream), to stuff all bit positions with 0's during that slot's active time.

SYNC remains high for a total duration of 16 BITCLKs at the beginning of each audio frame. The portion of the audio frame where SYNC is high is defined as the "Tag Phase". The remainder of the audio frame where SYNC is low is defined as the "Data Phase".

Note that SDATAOUT and SDATAIN data is delayed one BITCLK because AC'97 controller causes SYNC signal high at a rising edge of BITCLK which initiates a frame.

“Output” stream means the direction from AC'97 controller to the AK4651, and “Input” stream means the direction from the AK4651 to AC'97 controller.

■ AC-Link Protocol

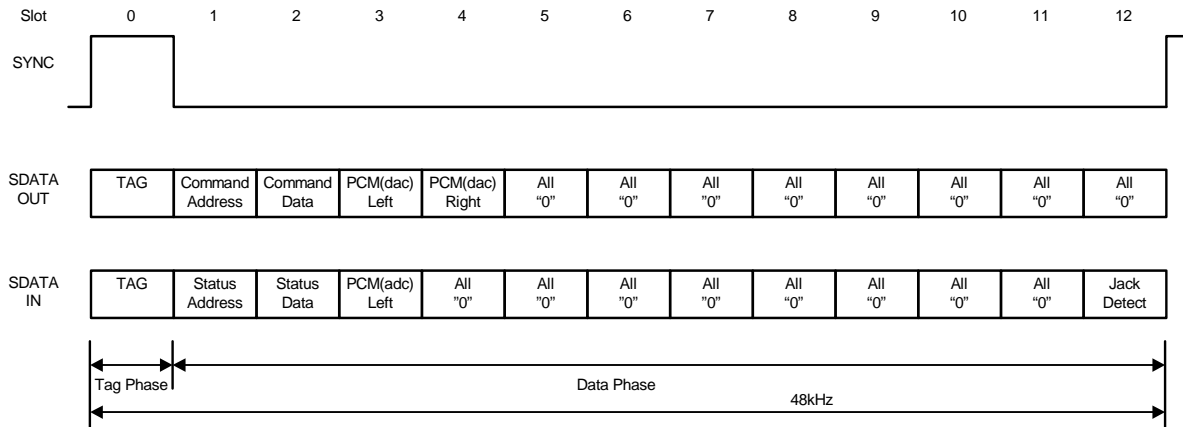

Figure 34. AC-Link protocol

AC-link protocol identifies 13 slots of data per frame. The frequency of SYNC is fixed to 48kHz. Only Slot 0, which is the Tag phase, is 16bits, all other slots are 20bits in length. These slots are explained in later sections.

1) AC-Link Audio Output Frame (SDATAOUT)

[Slot 0]

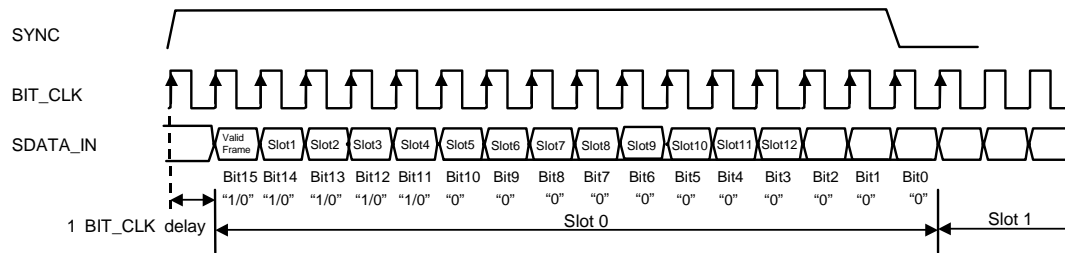

Figure 35. Slot 0

Slot 0 consists of sixteen bits (bit 15-0). Bit 15-11 are available in the AK4651. Each bit means valid by “1” and invalid by “0”.

Bit 15 (Valid Frame bit): Validity of the frame

“1” = At least one of bit 14-11 (slot 1-4) must be valid. Bit 10-0 are ignored.

“0” = The AK4651 ignores all following information in the frame.

Bit 14 (Slot 1 valid bit): Validity of slot 1 (command address input)

Bit 13 (Slot 2 valid bit): Validity of slot 2 (command data input)

Bit 12 (Slot 3 valid bit): Validity of slot 3 (DAC Left data input)

Bit 11 (Slot 4 valid bit): Validity of slot 4 (DAC Right data input)

If each bit is “0”, the AK4651 ignores the slot indicated by “0”. On the other hand, if each bit is “1”, the slot is valid. Bit 10-0 should be “0”.

A new audio output frame begins with a low to high transition of SYNC. SYNC is synchronous to the rising edge of BITCLK. On the immediately following falling edge of BITCLK, the AK4651 samples the assertion of SYNC. This falling edge marks the time when both sides of AC-link are aware of the start of a new audio frame. On the next rising of BITCLK, the AC '97 controller transitions SDATAOUT into the first bit position of slot 0 (Valid Frame bit). Each new bit position is presented to AC-link on a rising edge of BITCLK, and subsequently sampled by the AK4651 on the following falling edge of BITCLK. This sequence ensures that data transitions, and subsequent sample points for both incoming and outgoing data streams are time aligned.

Data should be sent to the AK4651 with MSB first through the SDATAOUT.

Table 41 shows the relationship of bit 14&13 and the Read/Write operation.

Bit 15 Valid Frame	Bit 14: Slot1 Valid Bit (Command Address)	Bit 13: Slot 2 Valid Bit (Command Data)	Read/Write Operation
1	1	1	Read/Write (Normal Operation)
1	0	1	Ignore
1	1	0	Read: Normal Operation Write: Ignore
1	0	0	Ignore

Table 41. AK4651 Addressing: Slot 0 Tag Bits

[Slot 1]: Command Address Port

Slot1 gives the address of the command data, which is given in the slot 2. The AK4651 has 30 valid registers of 16bit data. See "Mixer Registers".

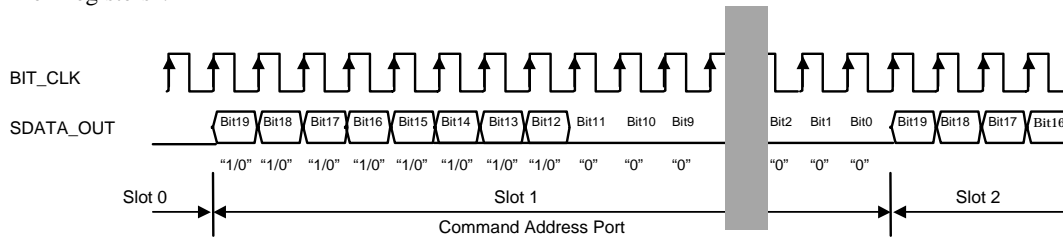

Figure 36. Slot 1

- Bit 19: Read/Write command (1bit; "1"=read, "0"=write)
- Bit 18-12: Control Register Index (7bit; see "Mixer Registers" for the detail)
- Bit 11-0: Reserved (12bit; "0")

Bit 18 of this slot 1 is equivalent to the most significant bit of the index register address.

The AK4651 ignores bit 11-0. These bits will be reserved for future enhancement and must be staffed with 0's by the AC'97 controller.

[Slot 2]: Command Data Port

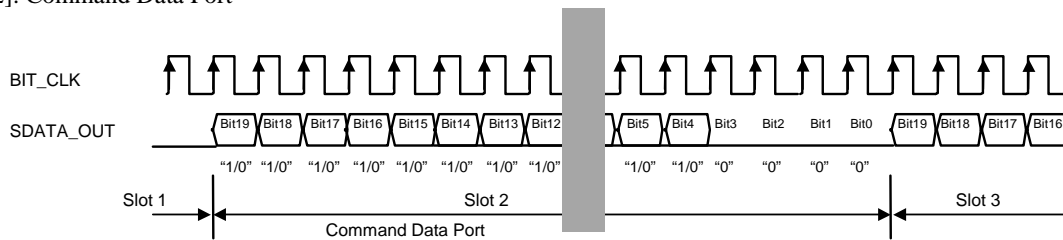

Figure 37. Slot 2

- Bit19-4: Control Register Write Data (16bit)
(If bit 19 of slot 1 is "1", all bit19-4 should be "0".)
- Bit3-0: Reserved (4bit; "0")

If bit 19 in slot 1 is "0", the AC'97 controller must output Command Data Port data in slot 2 **of the same frame**. If the bit 19 in slot 1 is "1", the AK4651 will ignore any Command Data Port data in slot 2.

Bit19 of this slot 2 is equivalent to D15 bit of mixer register value.

[Slot 3]: PCM Playback Left Channel (16bit)

The AK4651 uses the playback (DAC) data format in slot 3 for left channel. Playback data format is MSB first. Data format is 16bits 2's complement. AC'97 controller should stuff bit 3-0 with "0". If valid bit (slot 3) in the slot 0 is invalid ("0"), the AK4651 interprets the data as all "0".

Bit 19-4: Playback data (16bit)

Bit 3-0: "0" (4bit)

[Slot 4]: PCM Playback Right Channel (16bit)

The AK4651 uses the playback (DAC) data format in slot 4 for right channel. Playback data format is MSB first. Data format is 16bits 2's complement. AC'97 controller should stuff bit 3-0 with "0". If valid bit (slot 4) in the slot 0 is invalid ("0"), the AK4651 interprets the data as all "0".

Bit 19-4: Playback data (16bit)

Bit 3-0: "0" (4bit)

[Slot 5-12]: Not implemented in the AK4651

2) AC-Link Input Frame (SDATAIN)

Each AC-link frame consists of one 16bit tag phase and twelve 20bit slots used for data and control.

[Slot 0]

Slot 0 is a special time frame, and consists of 16bits. Slot 0 is also named the Tag phase. The AK4651 supports bits 15-11 and bit 3. Each bit indicates “1”=valid(normal operation) or ready, “0”=invalid (abnormal operation) or not ready. If the first bit in the slot 0 (Bit15 = “Codec Ready”) is valid, the AK4651 is ready for normal operation. If the “Codec Ready” bit is invalid, the following bits and remaining slots are all “0”. AC’97 controller should ignore the following bits in the slot 0 and all other slots. When the ADC sampling rate is set for less than 48kHz, then bits 12 and 11 in slot 0 (corresponds to slot 3 and slot 4 respectively) will be 1’s when valid data is transferred in SDATAIN, and will be 0’s when no data is transmitted.

< “On-demand” base data transaction >

For variable sample rate input, the tag bit for each input slot indicates whether valid data is present or not. Thus, even in variable sample rate mode, the AK4651 is always the master. For SDATAIN (AK4651 to Controller), the AK4651 sets the TAG bit. For SDATAOUT (Controller to AK4651), the AK4651 sets the SLOTRREQ bit and then checks for the TAG bit in the next frame. AK4651 expects Controller will reply TAG bit in the next frame correctly.

Bit 14 means that Slot 1 (Status Address) output is valid or invalid. And Bit 13 means that Slot 2 (Status Data) is valid or invalid. Table 42 shows the relationship between bit 14,13 and each Status of the AK4651.

Bit 15 (Codec Ready)	Bit 14 (Status Address)	Bit 13 (Status Data)	Status
1	1	1	There is a Read Command in the previous frame. Then both Slot 1 and Slot 2 output normal data. If the access to non-implemented register or odd register is requested, the AK4651 returns “valid” 7-bit register address in slot 1 and returns “valid” 0000h data in slot 2 on the next AC-link frame.
1	1	0	Prohibited or non-existing
1	0	1	Prohibited or non-existing
1	0	0	There is no Read Command in the previous frame. Bits 19-12 and 9-0 in Slot 1 are set to “0”. And Slot 2 outputs all “0”.

Table 42. SDATAIN Slot0

Note 39. The above Read sequence is done as response for previous frames read command. That is, if the previous frame is the Write Command, AK4651 outputs bit14 =”0”, bit13 =”0” and slot 1&2 = All”0”, if there is no SLOTRREQ.

Note 40. The Bits 14 and 13 in Slot 0 is independent of the SLOTRREQ Bits 11 and 10 in Slot 1 which the AK4651 supports.

Bits 12 and 3 mean the output of Slot 3 (PCM(ADC) Left) and Slot 12 are valid or invalid, respectively. Bit 11 is same as bit 12. Slot 4 is all “0” regardless of bit 11. Bits 10-4 and 2-0 are occupied with “0”.

A new audio input frame begins with a low to high transition of SYNC. SYNC is synchronous to the rising edge of BITCLK. On the immediately following falling edge of BITCLK, the AK4651 samples the assertion of SYNC. This falling edge marks the time when both sides of AC-link are aware of the start of a new audio frame. On the next rising edge of BITCLK, the AK4651 transitions SDATAIN into the first bit position of slot 0 (“Codec Ready” bit). Each new bit position is presented to AC-link on a rising edge of BITCLK, and subsequently sampled by the AC ’97 controller on the following falling edge of BITCLK. This sequence ensures that data transitions, and subsequent sample points for both incoming and outgoing data streams are time aligned.

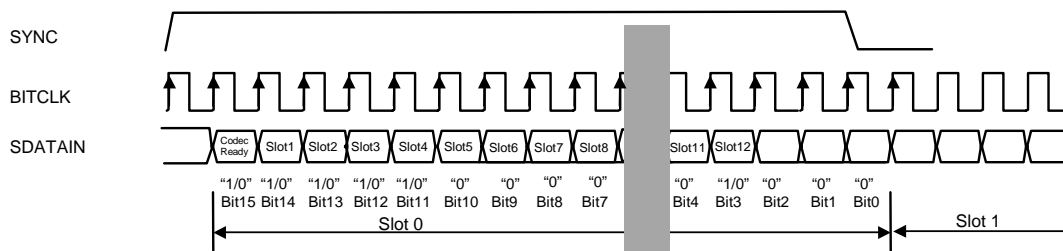

Figure 38. Slot 0

[Slot 1]: Status Address Port

Audio input frame slot 1’s stream echoes the control register index, for historical reference, for the data to be returned in slot 2. (Assuming that slot 1 valid bit and slot 2 valid bit in the slot 0 had been tagged “valid” by the AK4651.)

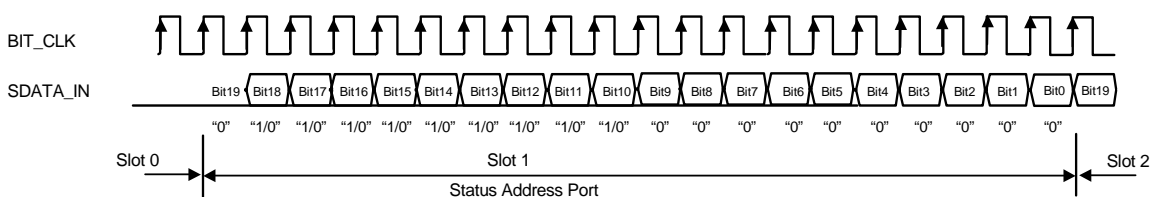

Figure 39. Slot 1

This address shows register index for which data is being returned in the slot 2. This address port is the copy of slot 1 of the output frame, and index address input to SDATAOUT is looped back to the AC’97 controller through SDATAIN even for non-supported register.

For “On Demand” base data transaction, when the DAC sampling rate is set less than 48kHz, then AK4651 will request new audio data as required by setting the SLOTREQ bits 11 and 10 in slot 1 to 0’s. When no data is required to support the selected sampling rate, these bits will be 1’s. When SLOTREQ bits are asserted as “send data request” during the current frame on SDATAIN, AC’97 digital controller should send data onto the corresponding slot in the next frame on SDATAOUT. If VRA bit is set to “0”, SLOTREQ bits always show “0” and sample rate is forced to 48kHz.

SLOTREQ Bit	Description
19	Reserved (Set to “0”)
18-12	Control Register Index (7bit; Set to “0” if tagged invalid)
11	Slot 3 Request: PCM Lch “0”: send data request, “1”: do not send
10	Slot 4 Request: PCM Rch “0”: send data request, “1”: do not send
9-0	Reserved (10bit; Set to “0”)

Table 43. SLOTREQ bit

[Slot 2]: Status Data Port

Status data addressed by command address port of Output Stream is output through SDATAIN pin.

- Bit 19-4 Control Register Read Data (16bit; the contents of indexed address in the slot 1)
- Bit 3-0 "0" (4bit)

Note that the address of Status Data Port data are consistent with Status Address Port data of the slot 1 **in the same frame**. If the read operation is issued in the frame N by AC'97 controller, Status Data Port data is output through SDATAIN in the frame N+1. **Note that data is output in only this frame, only one time and that the following frames are invalid if the next read operation is not issued.**

[Slot 3]: PCM Record Left Channel

Record (ADC) data format is MSB first. Data format is 2's complement. As the resolution of the AK4651 is 16bit, lower 4 bits are ignored. If ADC block is powered down, slot 3 valid bit in the slot 0 is invalid ("0"), and data is output as all "0".

- Bit 19-4: Audio ADC left channel output (16bit)
- Bit 3-0: "0" (4bit)

[Slot 4-11]: Reserved for future enhancement

- Bit 19-0 "0"

[Slot 12]: Headphone jack detection results

When SLOT bit = "1", headphone jack detection results are output.

- Bit 19-2: "0" (18bit)
- Bit 1: DTHPJ (1bit; "0"=Not inserted, "1"=Inserted)
- Bit 0: "0" (1bit)

■ Power On

Note that AK4651 must be in cold reset at power on and RESETN must be “L” until master crystal clock becomes stable, or cold reset must be done once after master clock is stable.

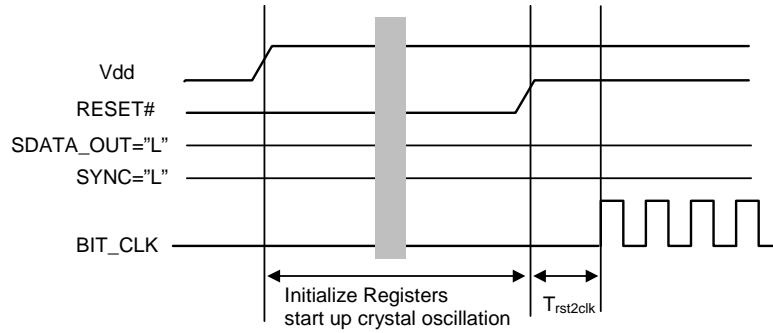

Figure 40. Power On Timing

■ Cold Reset

Note that both SDATAOUT and SYNC must be “L” at the rising edge of RESETN for cold reset.

The AK4651 initializes all registers including the Power-down Control Registers, BIT-CLK is reactivated and each analog output except for HP-Amp is in Hi-Z state while RESETN pin is “L”.

At the rising edge of RESETN, the AK4651 starts the initialization of ADC and DAC, which takes 1028TS cycles. After that, the AK4651 is ready for normal operation. At that time, VRA bit is its default value (“0”). Therefore, fs=48kHz and TS=1/fs=20.83μs.

Status bit in the slot 0 is “0” (not ready) when the AK4651 is in RESET period (“L”) or in initialization process. After initialization cycles, the status bit goes to “1” (ready).

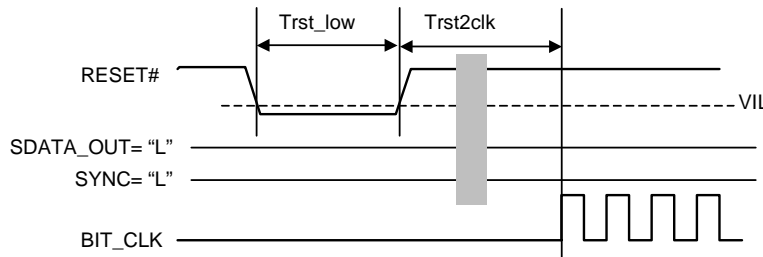

Figure 41. Cold Reset Timing

■ Warm Reset

The AK4651 initiates warm reset process by receiving a single pulse on the SYNC. The AK4651 clears PR4 bit and PR5 bit in the Power-down Control Register. However, warm reset does not influence PR0-3, 6 and 7 bits in Power-down Control Register.

Note 41. SYNC signal should synchronize with BITCLK after AK4651 starts to output BITCLK clock.

Note 42. If an external clock is used, external clocks should be supplied before issuing a sync pulse for warm reset. ADC and DAC require 1028TS for the initialization.

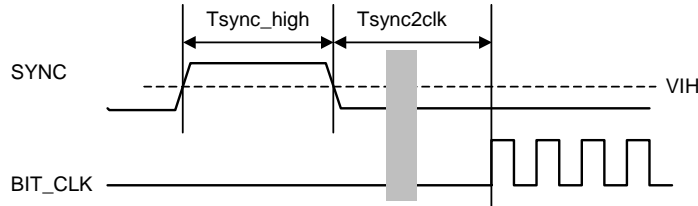

Figure 42. Warm Reset Timing

■ Active Test Mode

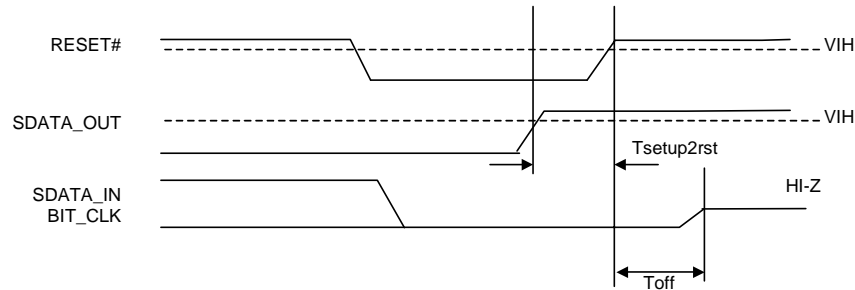

Figure 43. Activate Test Mode Timing

Note 43. All AC-link signals are normally low through the trailing edge of RESETN. Bringing RESETN high for the rising edge of SDATAOUT causes the AK4651 AC-link outputs to go high impedance which is suitable for ATE in circuit testing. Note that the AK4651 enters in the ATE test mode regardless SYNC is high or low.

Note 44. Once test modes have been entered, the only way to return to the normal operating state is to issue “cold reset” which issues RESETN with both SYNC and SDATAOUT “L”.

■ Register Map

Reg Num	Name	D15	D14	D13	D12	D11	D10	D9	D8	D7	D6	D5	D4	D3	D2	D1	D0	Default
00H	Reset	0	0	0	0	0	0	0	0	0	0	1	1	0	0	0	0	0030H
02H	Speaker Output	SPPS	0	0	0	0	0	0	0	0	0	0	0	0	0	0	0	8000H
04H	Headphone Output	HPMT	0	0	0	0	0	0	0	0	0	0	0	0	0	0	0	8000H
06H	Mono Output	MOMT	0	0	0	0	0	0	0	0	0	0	0	0	MOGN2	MOGN1	MOGN0	8000H
08H	Boost Control	0	0	0	0	BST1	BST0	0	0	0	0	0	0	0	0	0	0	0000H
0AH	PC_BEEP Volume	BPMT	0	0	0	0	0	0	0	0	0	0	0	0	0	0	0	8000H
0CH	Phone Volume	AUXMT	0	0	0	0	0	0	0	0	0	0	GN4	GN3	GN2	GN1	GN0	8008H
0EH	Mic Volume	MICMT	0	0	0	0	0	0	0	0	MGAIN	IPGA5	IPGA4	IPGA3	IPGA2	IPGA1	IPGA0	8008H
10H	Line In Volume	LNMT	0	0	GL4	GL3	GL2	GL1	GL0	0	0	0	GR4	GR3	GR2	GR1	GR0	8808H
18H	PCM Out Volume	SMUTE	ATTL6	ATTL5	ATTL4	ATTL3	ATTL2	ATTL1	ATTL0	0	ATTR6	ATTR5	ATTR4	ATTR3	ATTR2	ATTR1	ATTR0	0000H
1AH	Record Select	0	0	0	0	0	0	MICAD	AUXAD	0	0	0	0	0	0	0	0	0200H
20H	General Purpose	0	0	0	0	0	0	MDIF	MSEL	LOOP	0	0	0	0	0	0	0	0000H
26H	Powerdown Ctrl/Stat	0	PR6	PR5	PR4	PR3	PR2	PR1	PR0	0	0	0	0	0	ANL	DAC	ADC	0300H
28H	Extended Audio ID	0	0	0	0	0	0	0	0	0	0	0	0	0	0	0	1	0001H
2AH	Ext'd audio Stat/Ctrl	0	0	0	0	0	0	0	0	0	0	0	0	0	0	0	VRA	0000H
2CH	PCM Front DAC Rate	SR15	SR14	SR13	SR12	SR11	SR10	SR9	SR8	SR7	SR6	SR5	SR4	SR3	SR2	SR1	SR0	BB80H
32H	PCM LR ADC Rate	SR15	SR14	SR13	SR12	SR11	SR10	SR9	SR8	SR7	SR6	SR5	SR4	SR3	SR2	SR1	SR0	BB80H
60H	Power Management	MPWRE	MPWRI	0	0	0	0	MCKPD	PMSPK	PMHPR	PMHPL	PMBPM	PMLIN	PMMO	PMAUX	PMMIC	0000H	
62H	Signal Select	HPM	0	0	0	0	RNMD	LNMP	DAHS	AUXL	MICL	MICM	DAMO	BPMHP	BPMSP	ALCS	MO2	0103H
64H	ALC/DAC Control	0	HPINT	REF5	REF4	REF3	REF2	REF1	REF0	DATTC	0	ATSW	HPDT	TM1	TM0	DEM1	DEM0	2D21H
66H	ALC Mode Control	0	ALC2	ALC1	ZELMN	LMAT1	LMAT0	RGAIN	LMTH	0	ROTM	ZTM1	ZTM0	WTM1	WTM0	LTM1	LTM0	0000H
68H	Volume Cotrol	0	0	0	0	0	0	0	0	0	0	0	ATS	ATTM	ATTS2	ATTS1	ATTS0	0002H
6AH	Detect Result	0	0	0	0	0	0	0	0	0	0	0	0	0	0	DTHPJ	DTMIC	X
72H	Slot Control	1	0	0	0	0	1	0	0	0	0	0	0	0	0	0	SLOT	9400H
7CH	Vendor ID1	0	1	0	0	0	0	0	1	0	1	0	0	1	0	1	1	414BH
7EH	Vendor ID2	0	1	0	0	1	0	1	0	0	0	1	0	0	0	0	0	4D10H

Table 44. Register Map

Writing the data to the register address that is not in Table 44 is prohibited.

■ Speaker Output (02H)

SPPS: Speaker-amp Power-Save-Mode (Table 38)

- 0: Normal Operation
- 1: Power Save Mode (Default)

When the SPPS bit = "1", the Speaker-amp is in power-save-mode and the SPP pin becomes Hi-Z and SPN pin is set to HVDD/2 voltage. When the PMSPK bit = "1", this bit is valid. After the RESETN pin changes from "L" to "H", the PMSPK bit is "0", which powers down Speaker-amp

■ Headphone Output (04H)

HPMT: Headphone Amp Mute Control (Figure 25)

- 0: Mute OFF
- 1: Mute ON (Default)

■ Mono Output (06H)

MOMT: Mono Output Mute Control (Table 30)

- 0: Mute OFF
- 1: Mute ON (Default)

MOGN2-0: MOUT Volume Control (Table 31)

Default: "000" (+6dB)

■ Boost Control (08H)

BST1-0: Bass Boost Control (Table 24)

Default: "00" (OFF)

■ BEEP Volume (0AH)

BPMT: BEEP Input Mute Control

- 0: Mute OFF
- 1: Mute ON (Default)

■ Phone Volume (0CH)

AUXMT: AUX Input Mute Control (Table 28)

- 0: Mute OFF
- 1: Mute ON (Default)

GN4-0: AUX Input Volume Control (Table 28)

Default: "08H" (0dB)

■ MIC Volume (0EH)

MICMT: Mic Input Mute Control (Table 14)

- 0: Mute OFF
- 1: Mute ON (Default)

MGAIN: MIC-Amp Gain Control (Table 10)

- 0: 0dB (Default)
- 1: +20dB

IPGA5-0: IPGA Control (Table 14)

Default: "08H" (0dB)

■ Line In Volume (10H)

LNMT: Line Input Mute Control (Table 29)

0: Mute OFF

1: Mute ON (Default)

GL4-0: Lch Line Input Volume Control (Table 29)

Default: "08H" (0dB)

GR4-0: Rch Line Input Volume Control (Table 29)

Default: "08H" (0dB)

■ PCM Volume (18H)

SMUTE: Soft Mute Control (Figure 20)

0: Normal Operation (Default)

1: DAC outputs soft-muted

Soft mute operation is independent of digital attenuator and is performed in the digital domain.

ATTN/R6-0: Digital ATT Control (Table 25)

Default: "00H"(0dB)

■ Record Select Control Register (1AH)

AUXAD: AUXIN to ADC enable

0: OFF (Default)

1: ON

MICAD: IPGA to ADC enable

0: OFF

1: ON (Default)

■ General Purpose (20H)

LOOP: Internal Digital Loopback

0: OFF (Default)

1: ON

When LOOP bit is "1", VRA bit should be "0".

MSEL: Internal/External MIC Select (Table 9 at MDIF bit = "0")

0: Internal MIC (Default)

1: External MIC

MDIF: Differential MIC Input Select (Table 9)

0: Single-ended Input (Default)

1: Differential Input

■ Power Management (26H)

PR6-0: Power Management (Table 6)
Default: "0000011" (ADC, DAC Power down)

ANL: Analog Mixer Power-up (Read only)
0: NOT Ready
1: Ready

DAC: DAC ready to accept data (Read only)
0: NOT Ready
1: Ready

ADC: ADC ready to transmit data (Read only)
0: NOT Ready
1: Ready

■ Extended Audio Status & Control (2AH)

VRA: Enables Variable Rate Audio mode in conjunction with Audio Sample Rate Control Registers and tag-bit/SLOTREQ signaling.
0: OFF(Default). PLL is powered-down.
1: ON

■ Audio Sample Rate control Registers (2CH, 32H)

SR15-0: Sample Rate Control for DAC (2CH) and ADC (32H) (Table 4, Table 5)
Default: "BB80H"(48kHz)
These Sample Rate setting is done at VRA bit = "1".

■ Power Management (60H)

PMMIC: MIC Block (MIC-Amp and ALC1) Power Management

- 0: Power down (Default)
- 1: Power up

PMAUX: AUX Input Power Management

- 0: Power down (Default)
- 1: Power up

PMMO: Mono Line Output Power Management

- 0: Power down (Default)
- 1: Power up

PMLIN: Stereo Line Input Power Management

- 0: Power down (Default)
- 1: Power up

PMBPM: Mono Beep Input Power Management

- 0: Power down (Default)
- 1: Power up

Even if PMBPM= “0”, the path is still connected between BEEP pin and HP/SPK-Amp. BPMHP and BPMSP bits should be set to “0” to disconnect these paths, respectively.

PMHPR: Headphone-Amp Rch Power Management

- 0: Power down (Default)
- 1: Power up

PMHPL: Headphone-Amp Lch Power Management

- 0: Power down (Default)
- 1: Power up

PMSPK: Speaker-Amp Power Management

- 0: Power down (Default)
- 1: Power up

MCKPD: XTI pin pull down control

- 0: Master Clock input enable (Default)
- 1: XTI pin is internally pulled-down

MPWRI: Internal MIC Power Supply Control (Table 11)

- 0: OFF (Default)
- 1: MIC Power is ON for Internal MIC.
MPWRI bit is enabled when PMMIC bit = “1”.

MPWRE: External MIC Power Supply Control (Table 12)

- 0: OFF (Default)
- 1: MIC Power is ON for External MIC.
MPWRE bit is enabled when PMMIC bit = “1”.

■ Signal Select (62H)

MO2: Mono Output (MOUT2 pin) Enable

0: OFF

1: ON (Default)

When MO2 bit = "0", MOUT2 pin outputs VCOM voltage. MOUT2 pin outputs signal when MO2 bit = "1" and PMSPK bit = "1". MOUT2 pin goes to Hi-Z state when PMSPK bit = "0".

ALCS: ALC2 to Speaker-Amp Enable

0: OFF

1: ON (Default)

BPMSP: BEEP to Speaker-Amp Enable

0: OFF (Default)

1: ON

BPMHP: BEEP to Headphone-Amp Enable

0: OFF (Default)

1: ON

DAMO: DAC to Mono Line Output Enable

0: OFF (Default)

1: ON

MICM: IPGA to Mono Line Output Enable

0: OFF (Default)

1: ON

MICL: IPGA to Headphone/Speaker-Amp Enable

0: OFF (Default)

1: ON

AUXL: AUXIN to Headphone/Speaker-Amp Enable

0: OFF (Default)

1: ON

DAHS: DAC to Headphone/Speaker-Amp Enable

0: OFF

1: ON (Default)

LNMP: LIN/MPE pin Selection

0: MPE pin (Default)

1: LIN pin

RNMD: RIN/MDT pin Selection

0: MDT pin (Default)

1: RIN pin

HPM: Mono Output Select of Headphone

0: Stereo (Default)

1: Mono [(L+R)/2]

■ ALC/DAC Control (64H)

DEM1-0: De-emphasizes response (Table 23)
Default: "01" (OFF)

TM1-0: Soft Mute Time Select (Table 27)
Default: "00" (1024/fs)

HPDT: Headphone Jack Insertion Detection Function Enable
0: OFF (Default)
1: ON

ATSW: Headphone/Speaker Automatic Switch Function Enable by Headphone Jack Insertion (Table 35, Table 36)
0: OFF
1: ON (Default)

DATTC: DAC Digital Attenuator Control Mode Select
0: Independent
1: Dependent (Default)
When DATTC="1", ATTL6-0 bits control both Lch and Rch at the same time. ATTR6-0 bits are not changed when the ATTL6-0 bits are written.

REF5-0: Maximum IPGA value at ALC1 Recovery Operation (Table 21)
Default: "2DH" (+19dB)
During the ALC1 recovery operation, if the IPGA value exceeds the setting maximum value (REF5-0 bits) by gain operation, then the IPGA does not become larger than the maximum value.

HPINT: INTN pin Output Enable for Headphone Jack Detection
Default: "0" (OFF)
When HPINT bit = "1", INTN pin is enabled to output the interrupt signal of headphone jack detection.

■ ALC Control (66H)

LTM1-0: ALC1 limiter operation period at zero crossing disable (ZELMN bit = "1") (Table 17)
Default: "00" (0.5/fs)
The IPGA value is changed immediately when zero crossing is disabled (ZELMN bit = "1"). When the IPGA value is changed continuously, the change is done by the period specified by the LTM1-0 bits.

WTM1-0: ALC1 Recovery Waiting Period (Table 19)
Default: "00" (128/fs)
WTM1-0 bits set a period of recovery operation when any limiter operation does not occur during the ALC1 operation.

ZTM1-0: ALC1 zero crossing timeout selection (Table 18)
Default: "00" (128/fs)
When the IPGA performs zero crossing or timeout, the IPGA value is changed by the μ P WRITE operation, ALC1 recovery operation or ALC1 limiter operation (ZELMN bit = "0").

ROTM: ALC2 Recovery Waiting Period (Table 39)

0: 2048/fs (Default)

1: 512/fs

LMTH: ALC1 Limiter Detection Level / Recovery Waiting Counter Reset Level (Table 15)

Default: "0" (-6dB/-8dB)

The ALC1 limiter detection level and the ALC1 recovery counter reset level may be offset by about ± 2 dB.

RGAIN: ALC1 Recovery GAIN Step (Table 20)

Default: "0" (0.5dB)

During the ALC1 recovery operation, RGAIN bit sets the number of steps changed from the current IPGA value. For example, when the current IPGA value is "30H" and RGAIN bit is "1", the IPGA changes to "32H" by the ALC1 recovery operation and the output signal level is gained up by 1dB (=0.5dB x 2). When the IPGA value exceeds the maximum level (REF6-0 bits), the IPGA value does not increase.

LMAT1-0: ALC1 Limiter ATT Step (Table 16)

Default: "00" (0.5dB)

During the ALC1 limiter operation, when IPGA value exceeds the ALC1 limiter detection level set by LMTH bit, LMAT1-0 bits set the number of steps attenuated from the current IPGA value. For example, when the current IPGA value is "47H" and LMAT1-0 bits is "11", the IPGA value decreases to "43H" when the ALC1 limiter operation starts, resulting in the input signal level being attenuated by 2dB (=0.5dB x 4). When the attenuation value exceeds IPGA = "00" (-8dB), it clips to "00".

ZELMN: Zero crossing detection enable at ALC1 Limiter operation

0: Enable (Default)

1: Disable

When the ZELMN bit = "0", the IPGA performs a zero crossing or timeout and the IPGA value is changed by the ALC1 operation. The zero crossing timeout is the same as the ALC1 recovery operation. When the ZELMN bit = "1", the IPGA value is changed immediately.

ALC1: ALC1 enable

0: ALC1 Disable (Default)

1: ALC1 Enable

ALC2: ALC2 enable

0: ALC2 Disable (Default)

1: ALC2 Enable

■ Volume Control (68H)

ATTS2-0: Volume control of signal from IPGA to Headphone/Speaker-Amp (Table 7)

Default: "2H" (-12dB)

ATTM: Volume control of signal from IPGA to Mono Line Output (Table 8)

0: 0dB (Default)

1: -4dB

ATS: Digital attenuator transition time setting (Table 26)

Default: "0" (531/fs)

■ Detect Result (6AH)

DTMIC: MIC detection result (Read only, Table 13)

0: Microphone is not detected.

1: Microphone is detected

DTHPJ: Headphone jack insertion detection result (Read only, Table 34)

0: Headphone jack is not inserted.

1: Headphone jack is inserted.

■ Slot Control (72H)

SLOT: Headphone jack insertion detection result output select on Slot 12

0: Disable (Default)

1: Enable

■ Vendor ID (7CH, 7EH)

“A(41H), K(4BH), M(4DH), 16(10H)” (Read only)

SYSTEM DESIGN

Figure 44 shows the system connection diagram for the AK4651. An evaluation board [AKD4651] is available which demonstrates the optimum layout, power supply arrangements and measurement results.

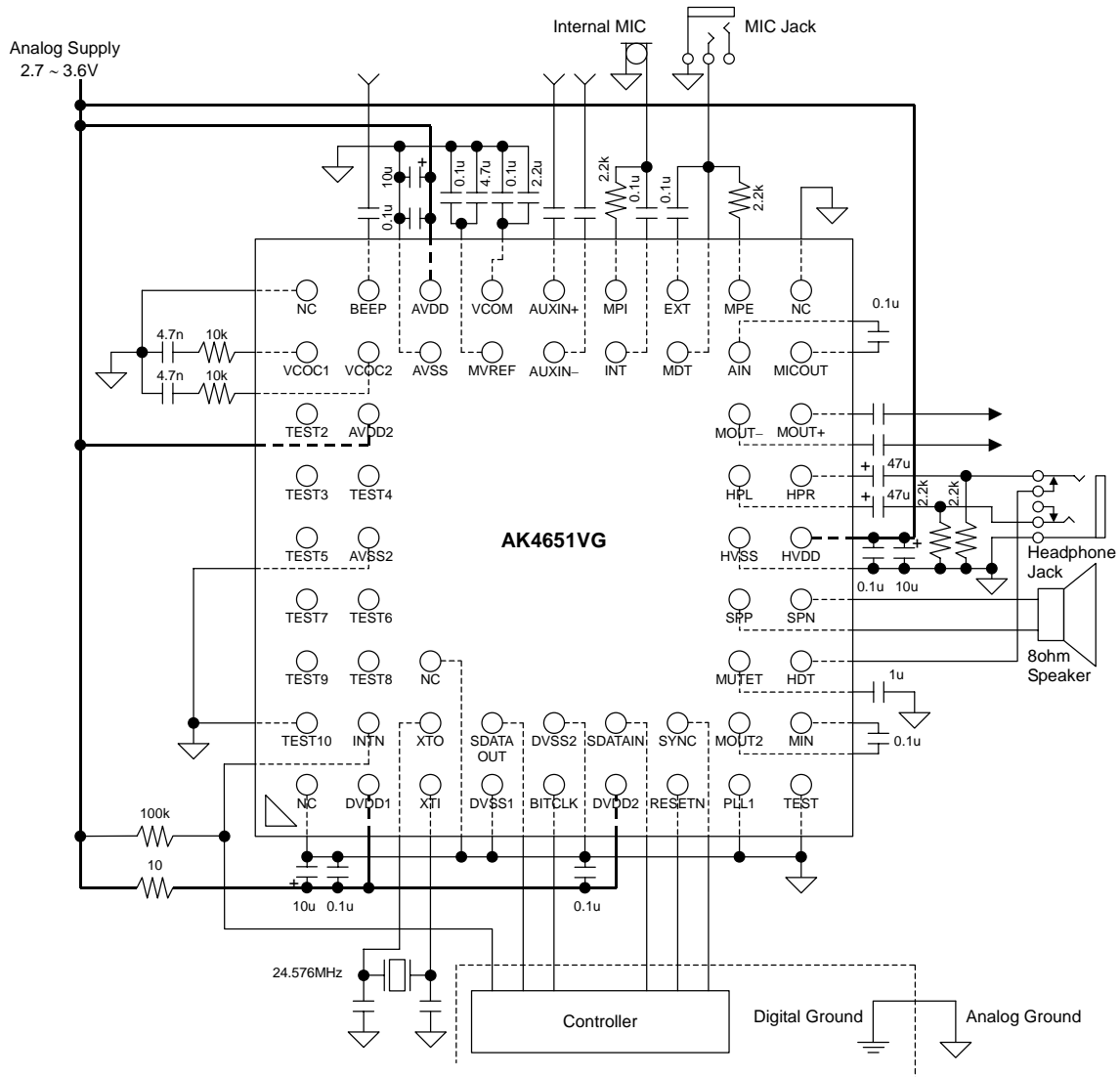

Note 45. AVSS, DVSS and HVSS of the AK4651 should be distributed separately from the ground of external controllers.

Note 46. All input pins except for internal pull-down pins should not be left floating.

Figure 44. Typical Connection Diagram

1. Grounding and Power Supply Decoupling

The AK4651 requires careful attention to power supply and grounding arrangements. AVDD, DVDD, HVDD and TSVDD are usually supplied from the system's analog supply. If AVDD, DVDD and HVDD are supplied separately, the correct power up sequence should be observed. AVSS, DVSS, HVSS and TSVSS of the AK4651 should be connected to the analog ground plane. System analog ground and digital ground should be connected together near to where the supplies are brought onto the printed circuit board. Decoupling capacitors should be as near to the AK4651 as possible, with the small value ceramic capacitor being the nearest.

2. Voltage Reference

VCOM is a signal ground of this chip. A 2.2 μ F electrolytic capacitor in parallel with a 0.1 μ F ceramic capacitor attached to the VCOM pin eliminates the effects of high frequency noise. No load current may be drawn from the VCOM pin. All signals, especially clocks, should be kept away from the VREF and VCOM pins in order to avoid unwanted coupling into the AK4651.

3. Analog Inputs

The Mic, Beep and stereo line inputs are single-ended. AUX input is differential. The input signal range scales with nominally at 0.06 x AVDD Vpp for the Mic input, 0.6 x AVDD Vpp for the Beep input, stereo line input and AUX input, centered around the internal common voltage (0.45 x AVDD). Usually the input signal is AC coupled using a capacitor. The cut-off frequency is $f_c = (1/2\pi RC)$. The AK4651 can accept input voltages from AVSS to AVDD.

4. Analog Outputs

The input data format for the DAC is 2's complement. The output voltage is a positive full scale for 7FFFH(@16bit) and a negative full scale for 8000H(@16bit). Mono output from the MOUT2 pin and Mono Line Output from the MOUT+/MOUT- pins are centered at 0.45 x AVDD, Headphone-Amp is centered at 0.44 x AVDD and Speaker-Amp output is centered at HVDD/2, respectively.

PACKAGE

57pin BGA (Unit: mm)

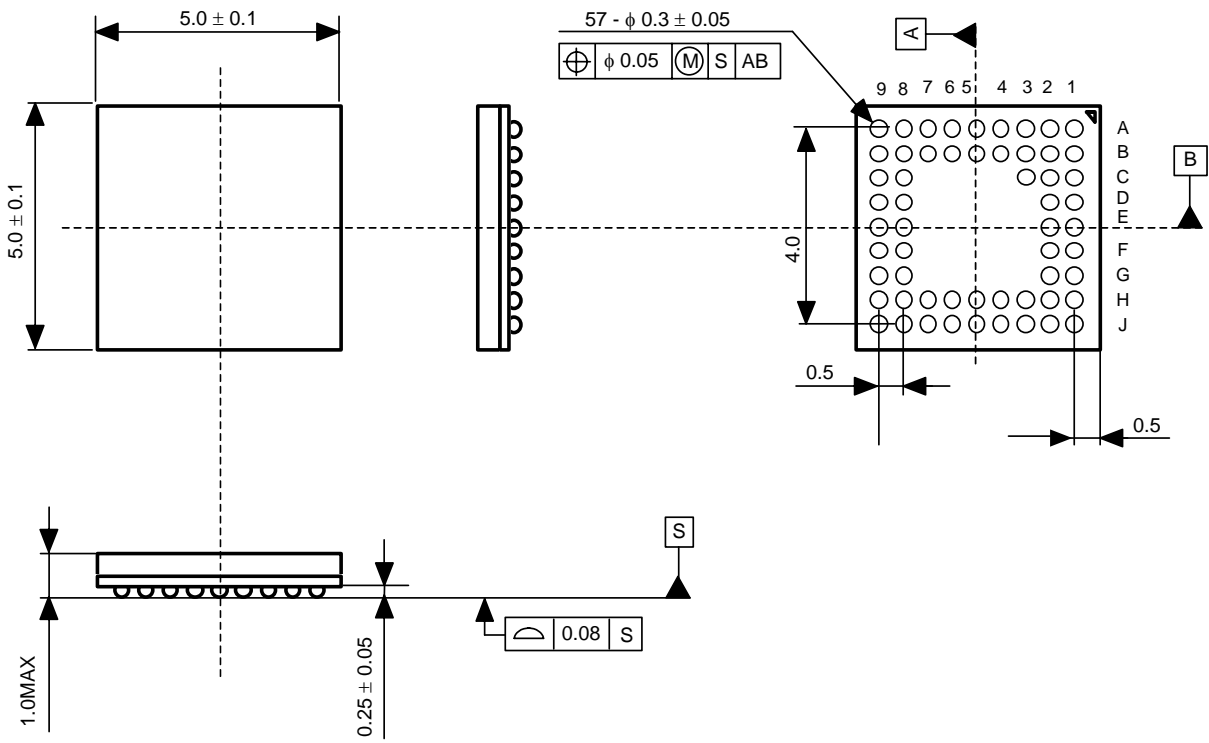

■ Material & Lead finish

Package molding compound:	Epoxy
Interposer material:	BT resin
Solder ball material:	SnAgCu

MARKING

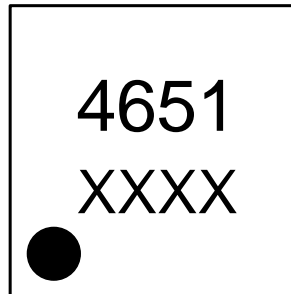

XXXX: Date code (4 digit)
Pin #1 indication

Revision History

Date (YY/MM/DD)	Revision	Reason	Page	Contents
06/04/24	00	First Edition		

IMPORTANT NOTICE

- These products and their specifications are subject to change without notice. Before considering any use or application, consult the Asahi Kasei Microsystems Co., Ltd. (AKM) sales office or authorized distributor concerning their current status.
- AKM assumes no liability for infringement of any patent, intellectual property, or other right in the application or use of any information contained herein.
- Any export of these products, or devices or systems containing them, may require an export license or other official approval under the law and regulations of the country of export pertaining to customs and tariffs, currency exchange, or strategic materials.
- AKM products are neither intended nor authorized for use as critical components in any safety, life support, or other hazard related device or system, and AKM assumes no responsibility relating to any such use, except with the express written consent of the Representative Director of AKM. As used here:
 - a. A hazard related device or system is one designed or intended for life support or maintenance of safety or for applications in medicine, aerospace, nuclear energy, or other fields, in which its failure to function or perform may reasonably be expected to result in loss of life or in significant injury or damage to person or property.
 - b. A critical component is one whose failure to function or perform may reasonably be expected to result, whether directly or indirectly, in the loss of the safety or effectiveness of the device or system containing it, and which must therefore meet very high standards of performance and reliability.
- It is the responsibility of the buyer or distributor of an AKM product who distributes, disposes of, or otherwise places the product with a third party to notify that party in advance of the above content and conditions, and the buyer or distributor agrees to assume any and all responsibility and liability for and hold AKM harmless from any and all claims arising from the use of said product in the absence of such notification.