

■ Block Diagram

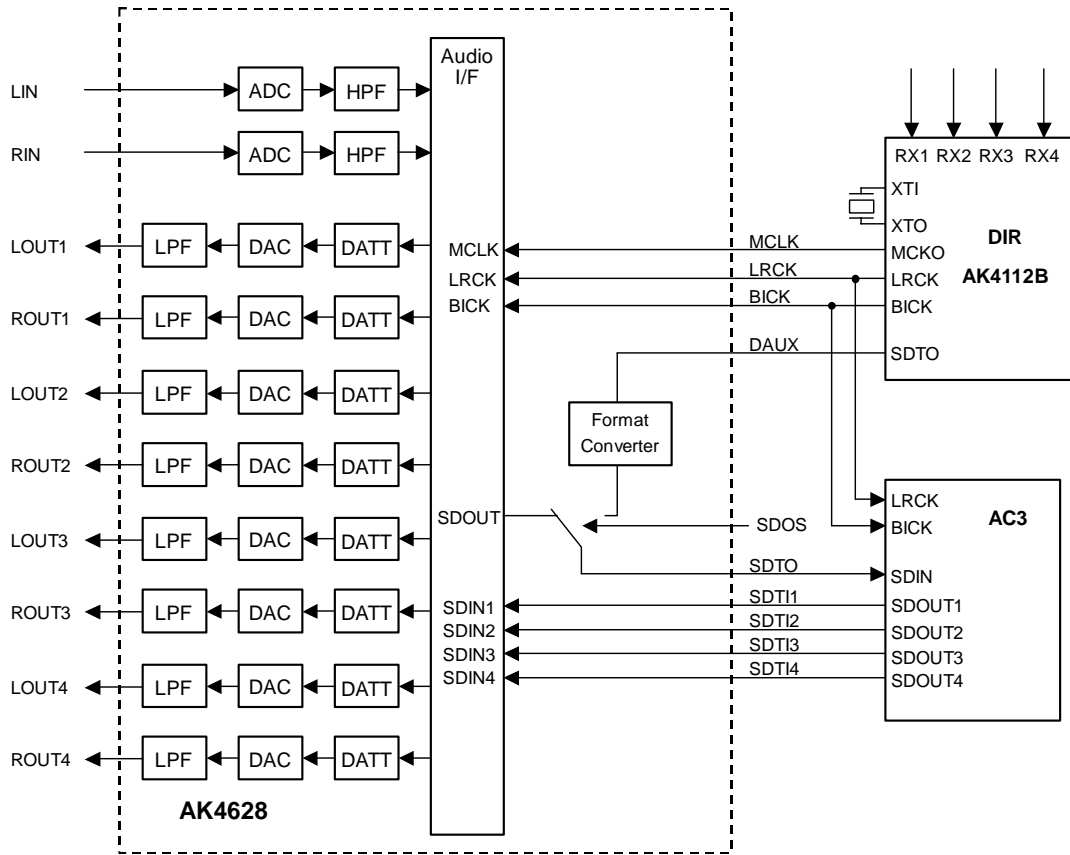

Block Diagram (DIR and AC-3 DSP are external parts)

■ Ordering Guide

AK4628VQ
AKD4628

-40 ~ +85°C
Evaluation Board for AK4628

44pin LQFP(0.8mm pitch)

■ Pin Layout

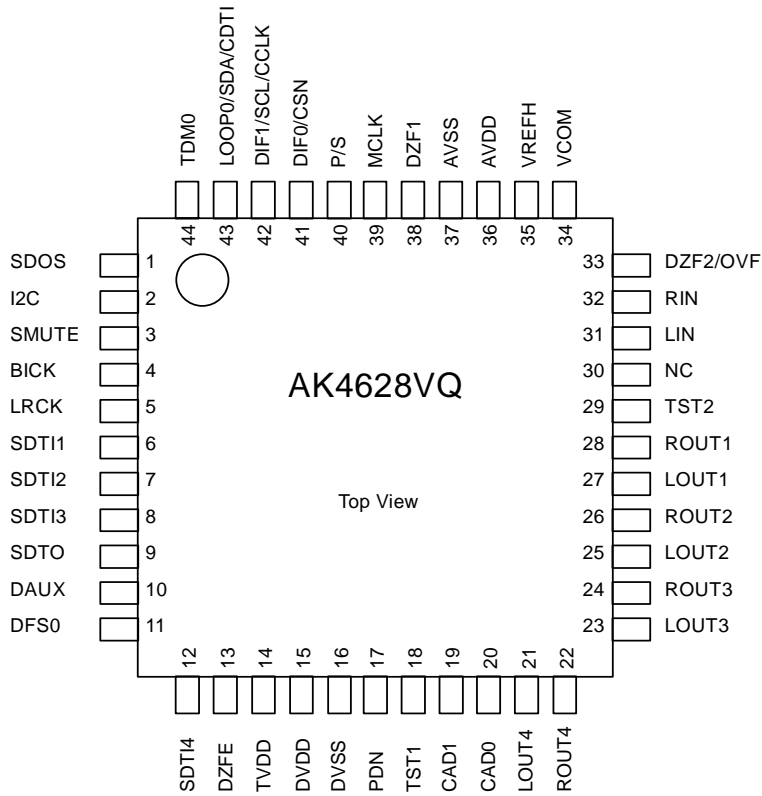

■ Compatibility with AK4529

1. Functions

Functions	AK4529	AK4628
DAC Sampling frequency	Up to 96kHz	Up to 192kHz
TDM128 (96kHz)	Not available	Available
Digital Attenuator	256 levels	128 levels
Soft Mute	Soft mute function is independent of Digital attenuator.	Soft mute function is not independent of Digital attenuator.
DAC channel power-down	Not available	Available

2. Pin Configuration

pin#	AK4529	AK4628
11	DFS	DFS0
18	TST	TST1
29	NC	TST2
44	TDM	TDM0

3. Register

Addr	AK4529	AK4628
00H	TDM	TDM0
00H	Not available	TDM1
01H	DFS	DFS0
01H	Not available	DFS1
01H	Not available	CKS1, CKS0
09H	Not available	PD4, PD3, PD2, PD1

PIN/FUNCTION			
No.	Pin Name	I/O	Function
1	SDOS	I	SDTO Source Select Pin (Note 1) “L”: Internal ADC output, “H”: DAUX input SDOS pin should be set to “L” when TDM= “1”.
2	I2C	I	Control Mode Select Pin “L”: 3-wire Serial, “H”: I ² C Bus
3	SMUTE	I	Soft Mute Pin (Note 1) When this pin goes to “H”, soft mute cycle is initialized. When returning to “L”, the output mute releases.
4	BICK	I	Audio Serial Data Clock Pin
5	LRCK	I	Input Channel Clock Pin
6	SDTI1	I	DAC1 Audio Serial Data Input Pin
7	SDTI2	I	DAC2 Audio Serial Data Input Pin
8	SDTI3	I	DAC3 Audio Serial Data Input Pin
9	SDTO	O	Audio Serial Data Output Pin
10	DAUX	I	AUX Audio Serial Data Input Pin
11	DFS0	I	Double Speed Sampling Mode Pin (Note 1) “L”: Normal Speed, “H”: Double Speed
12	SDTI4	I	DAC4 Audio Serial Data Input Pin
13	DZFE	I	Zero Input Detect Enable Pin “L”: mode 7 (disable) at parallel mode, zero detect mode is selectable by DZFM3-0 bits at serial mode “H”: mode 0 (DZF1 is AND of all eight channels)
14	TVDD	-	Output Buffer Power Supply Pin, 2.7V~5.5V
15	DVDD	-	Digital Power Supply Pin, 4.5V~5.5V
16	DVSS	-	Digital Ground Pin, 0V
17	PDN	I	Power-Down & Reset Pin When “L”, the AK4628 is powered-down and the control registers are reset to default state. If the state of P/S or CAD1-0 changes, then the AK4628 must be reset by PDN.
18	TST1	I	Test Pin This pin should be connected to DVSS.
19	CAD1	I	Chip Address 1 Pin
20	CAD0	I	Chip Address 0 Pin
21	LOUT4	O	DAC4 Lch Analog Output Pin
22	ROUT4	O	DAC4 Rch Analog Output Pin

No.	Pin Name	I/O	Function
23	LOUT3	O	DAC3 Lch Analog Output Pin
24	ROUT3	O	DAC3 Rch Analog Output Pin
25	LOUT2	O	DAC2 Lch Analog Output Pin
26	ROUT2	O	DAC2 Rch Analog Output Pin
27	LOUT1	O	DAC1 Lch Analog Output Pin
28	ROUT1	O	DAC1 Rch Analog Output Pin
29	TST2	I	Test pin (Internal pull-down pin) This pin should be left floating or connected to AVSS.
30	NC	-	No Connect No internal bonding.
31	LIN	I	Lch Analog Input Pin
32	RIN	I	Rch Analog Input Pin
33	DZF2	O	Zero Input Detect 2 Pin (Note 2) When the input data of the group 1 follow total 8192 LRCK cycles with "0" input data, this pin goes to "H". And when RSTN bit is "0", PWDAN pin is "0", this pin goes to "H". It always is in "L" when P/S is "H".
	OVF	O	Analog Input Overflow Detect Pin (Note 3) This pin goes to "H" if the analog input of Lch or Rch overflows.
34	VCOM	O	Common Voltage Output Pin, AVDD/2 Large external capacitor around 2.2μF is used to reduce power-supply noise.
35	VREFH	I	Positive Voltage Reference Input Pin, AVDD
36	AVDD	-	Analog Power Supply Pin, 4.5V~5.5V
37	AVSS	-	Analog Ground Pin, 0V
38	DZF1	O	Zero Input Detect 1 Pin (Note 2) When the input data of the group 1 follow total 8192 LRCK cycles with "0" input data, this pin goes to "H". And when RSTN bit is "0", PWDAN pin is "0", this pin goes to "H". Output is selected by setting DZFE pin when P/S is "H".
39	MCLK	I	Master Clock Input Pin
40	P/S	I	Parallel/Serial Select Pin "L": Serial control mode, "H": Parallel control mode
41	DIF0	I	Audio Data Interface Format 0 Pin in parallel control mode
	CSN	I	Chip Select Pin in 3-wire serial control mode This pin should be connected to DVDD at I ² C bus control mode
42	DIF1	I	Audio Data Interface Format 1 Pin in parallel control mode
	SCL/CCLK	I	Control Data Clock Pin in serial control mode I2C = "L": CCLK (3-wire Serial), I2C = "H": SCL (I ² C Bus)
43	LOOP0	I	Loopback Mode 0 Pin in parallel control mode Enables digital loop-back from ADC to 4 DACs.
	SDA/CDTI	I/O	Control Data Input Pin in serial control mode I2C = "L": CDTI (3-wire Serial), I2C = "H": SDA (I ² C Bus)
44	TDM0	I	TDM I/F Format Mode Pin (Note 1) "L": Normal mode, "H": TDM mode

- Notes: 1. SDOS, SMUTE, DFS0, and TDM0 pins are ORed with register data if P/S = "L".
2. The group 1 and 2 can be selected by DZFM3-0 bits if P/S = "L" and DZFE = "L".
3. This pin becomes OVF pin if OVFE bit is set to "1" at serial control mode.
4. All digital input pins except for pull-down should not be left floating.

ABSOLUTE MAXIMUM RATINGS

(AVSS, DVSS=0V; Note 5)

Parameter		Symbol	min	max	Units
Power Supplies	Analog	AVDD	-0.3	6.0	V
	Digital	DVDD	-0.3	6.0	V
	Output buffer	TVDD	-0.3	6.0	V
	AVSS-DVSS (Note 6)	ΔGND	-	0.3	V
Input Current (any pins except for supplies)		IIN	-	±10	mA
Analog Input Voltage		VINA	-0.3	AVDD+0.3	V
Digital Input Voltage (Expect LRCK, BICK pins) (LRCK, BICK pins)		VIND1 VIND2	-0.3 -0.3	DVDD+0.3 TVDD+0.3	V V
Ambient Temperature (power applied)		Ta	-40	85	°C
Storage Temperature		Tstg	-65	150	°C

Notes: 5. All voltages with respect to ground.

6. AVSS and DVSS must be connected to the same analog ground plane.

WARNING: Operation at or beyond these limits may result in permanent damage to the device.
Normal operation is not guaranteed at these extremes.

RECOMMENDED OPERATING CONDITIONS

(AVSS, DVSS=0V; Note 5)

Parameter		Symbol	min	typ	max	Units
Power Supplies (Note 7)	Analog	AVDD	4.5	5.0	5.5	V
	Digital	DVDD	4.5	5.0	5.5	V
	Output buffer	TVDD	2.7	5.0	5.5	V

Notes: 5. All voltages with respect to ground.

7. The power up sequence between AVDD, DVDD and TVDD is not critical.

Do not turn off only the AK4628 under the condition that a surrounding device is powered on and the I2C bus is in use.

WARNING: AKM assumes no responsibility for the usage beyond the conditions in this datasheet.

ANALOG CHARACTERISTICS

(Ta=25°C; AVDD, DVDD, TVDD=5V; AVSS, DVSS=0V; VREFH=AVDD; fs=48kHz; BICK=64fs;
Signal Frequency=1kHz; 24bit Data; Measurement Frequency=20Hz~20kHz at 48kHz, 20Hz~40kHz at fs=96kHz,
20Hz~40kHz at fs=192kHz; unless otherwise specified)

Parameter		min	typ	max	Units
ADC Analog Input Characteristics					
Resolution				24	Bits
S/(N+D) (-0.5dBFS)	fs=48kHz	84	92		dB
			86		dB
DR (-60dBFS)	fs=48kHz, A-weighted	94	102		dB
	fs=96kHz	88	96		dB
	fs=96kHz, A-weighted	93	102		dB
S/N (Note 8)	fs=48kHz, A-weighted	94	102		dB
	fs=96kHz	88	96		dB
	fs=96kHz, A-weighted	93	102		dB
Interchannel Isolation		90	110		dB
DC Accuracy					
Interchannel Gain Mismatch			0.2	0.3	dB
Gain Drift			20	-	ppm/°C
Input Voltage	A _{IN} =0.62xVREFH	2.90	3.10	3.30	V _{pp}
Input Resistance	(Note 9)	15	25		kΩ
Power Supply Rejection	(Note 10)		50		dB
DAC Analog Output Characteristics					
Resolution				24	Bits
S/(N+D)	fs=48kHz	80	90		dB
	fs=96kHz	78	88		dB
	fs=192kHz	-	88		dB
DR (-60dBFS)	fs=48kHz, A-weighted	95	106		dB
	fs=96kHz	88	100		dB
	fs=96kHz, A-weighted	94	106		dB
	fs=192kHz	-	100		dB
	fs=192kHz, A-weighted	-	106		dB
S/N (Note 11)	fs=48kHz, A-weighted	95	106		dB
	fs=96kHz	88	100		dB
	fs=96kHz, A-weighted	94	106		dB
	fs=192kHz	-	100		dB
	fs=192kHz, A-weighted	-	106		dB
Interchannel Isolation		90	110		dB
DC Accuracy					
Interchannel Gain Mismatch			0.2	0.5	dB
Gain Drift			20	-	ppm/°C
Output Voltage	A _{OUT} =0.6xVREFH	2.75	3.0	3.25	V _{pp}
Load Resistance		5			kΩ
Power Supply Rejection	(Note 10)		50		dB

- Notes: 8. S/N measured by CCIR-ARM is 98dB(@fs=48kHz).
9. Input resistance is 16kΩ typically at fs=96kHz.
10. PSR is applied to AVDD, DVDD and TVDD with 1kHz, 50mVpp. VREFH pin is held a constant voltage.
11. S/N measured by CCIR-ARM is 102dB(@fs=48kHz).

Parameter	min	typ	max	Units
Power Supplies				
Power Supply Current (AVDD+DVDD+TVDD)				
Normal Operation (PDN = "H")				
AVDD		45	67	mA
	fs=48kHz, 96kHz	34	51	mA
DVDD+TVDD		18	27	mA
	fs=48kHz (Note 12)	24	36	mA
	fs=96kHz	27	40	mA
Power-down mode (PDN = "L")		80	200	μA
	(Note 13)			

Notes: 12. TVDD=0.1mA(typ).

13. In the power-down mode. All digital input pins including clock pins (MCLK, BICK, LRCK) are held DVSS.

FILTER CHARACTERISTICS							
(Ta=25°C; AVDD, DVDD=4.5~5.5V; TVDD=2.7~5.5V; fs=48kHz)							
Parameter	Symbol	min	typ	max	Units		
ADC Digital Filter (Decimation LPF):							
Passband (Note 14)		±0.1dB	PB	0		18.9	kHz
		-0.2dB		-	20.0	-	kHz
		-3.0dB		-	23.0	-	kHz
Stopband	SB	28				kHz	
Passband Ripple	PR			±0.04		dB	
Stopband Attenuation	SA	68				dB	
Group Delay (Note 15)	GD		16			1/fs	
Group Delay Distortion	ΔGD		0			μs	
ADC Digital Filter (HPF):							
Frequency Response (Note 14)		-3dB	FR		1.0		Hz
		-0.1dB			6.5		Hz
DAC Digital Filter:							
Passband (Note 14)		-0.1dB	PB	0		21.8	kHz
		-6.0dB		-	24.0	-	kHz
Stopband	SB	26.2				kHz	
Passband Ripple	PR			±0.02		dB	
Stopband Attenuation	SA	54				dB	
Group Delay (Note 15)	GD		19.2			1/fs	
DAC Digital Filter + Analog Filter:							
Frequency Response:		0 ~ 20.0kHz	FR		±0.2		dB
		40.0kHz (Note 16)	FR		±0.3		dB
		80.0kHz (Note 16)	FR		±1.0		dB

Notes:

14. The passband and stopband frequencies scale with fs.
For example, 21.8kHz at -0.1dB is 0.454 x fs.
15. The calculating delay time which occurred by digital filtering. This time is from setting the input of analog signal to setting the 24bit data of both channels to the output register for ADC.
For DAC, this time is from setting the 20/24bit data of both channels on input register to the output of analog signal.
16. 40.0kHz; fs=96kHz , 80.0kHz; fs=192kHz.

DC CHARACTERISTICS						
(Ta=25°C; AVDD, DVDD=4.5~5.5V; TVDD=2.7~5.5V)						
Parameter	Symbol	min	typ	max	Units	
High-Level Input Voltage	VIH	2.2	-	-	V	
Low-Level Input Voltage	VIL	-	-	0.8	V	
High-Level Output Voltage	(SDTO, LRCK, BICK pins: Iout=-100μA)	VOH	TVDD-0.5	-	-	V
		VOH	AVDD-0.5	-	-	V
Low-Level Output Voltage	(SDTO, LRCK, BICK, DZF1, DZF2/OVF pins: Iout= 100μA)	VOL	-	-	0.5	V
		VOL	-	-	0.4	V
Input Leakage Current	(Note 17)	Iin	-	-	±10	μA

Note 17: TST2 pin has an internal pull-down device, nominally 100kohm.

SWITCHING CHARACTERISTICS

(Ta=25°C; AVDD, DVDD=4.5~5.5V; TVDD=2.7~5.5V; CL=20pF)

Parameter	Symbol	min	typ	max	Units
Master Clock Timing					
256fsn, 128fsd:	fCLK	8.192		12.288	MHz
Pulse Width Low	tCLKL	27			ns
Pulse Width High	tCLKH	27			ns
384fsn, 192fsd:	fCLK	12.288		18.432	MHz
Pulse Width Low	tCLKL	20			ns
Pulse Width High	tCLKH	20			ns
512fsn, 256fsd:	fCLK	16.384		24.576	MHz
Pulse Width Low	tCLKL	15			ns
Pulse Width High	tCLKH	15			ns
LRCK Timing					
Normal mode (TDM0= "0", TDM1= "0")					
Normal Speed Mode	fsn	32		48	kHz
Double Speed Mode	fsd	64		96	kHz
Quad Speed Mode	fsq	120		192	kHz
Duty Cycle	Duty	45		55	%
TDM256 mode (TDM0= "1", TDM1= "0")					
LRCK frequency	fsn	32		48	kHz
"H" time	tLRH	1/256fs			ns
"L" time	tLRL	1/256fs			ns
TDM128 mode (TDM0= "1", TDM1= "1")					
LRCK frequency	fsn	64		96	kHz
"H" time	tLRH	1/128fs			ns
"L" time	tLRL	1/128fs			ns
Audio Interface Timing					
Normal mode (TDM0= "0", TDM1= "0")					
BICK Period	tBCK	81			ns
BICK Pulse Width Low	tBCKL	32			ns
Pulse Width High	tBCKH	32			ns
LRCK Edge to BICK "↑" (Note 18)	tLRB	20			ns
BICK "↑" to LRCK Edge (Note 18)	tBLR	20			ns
LRCK to SDTO(MSB)	tLRS			40	ns
BICK "↓" to SDTO	tBSD			40	ns
SDTI1-4,DAUX Hold Time	tSDH	20			ns
SDTI1-4,DAUX Setup Time	tSDS	20			ns
TDM256 mode (TDM0= "1", TDM1= "0")					
BICK Period	tBCK	81			ns
BICK Pulse Width Low	tBCKL	32			ns
Pulse Width High	tBCKH	32			ns
LRCK Edge to BICK "↑" (Note 18)	tLRB	20			ns
BICK "↑" to LRCK Edge (Note 18)	tBLR	20			ns
BICK "↓" to SDTO	tBSD			20	ns
SDTI1 Hold Time	tSDH	10			ns
SDTI1 Setup Time	tSDS	10			ns
TDM128 mode (TDM0= "1", TDM1= "1")					
BICK Period	tBCK	81			ns
BICK Pulse Width Low	tBCKL	32			ns
Pulse Width High	tBCKH	32			ns
LRCK Edge to BICK "↑" (Note 18)	tLRB	20			ns
BICK "↑" to LRCK Edge (Note 18)	tBLR	20			ns
BICK "↓" to SDTO	tBSD			20	ns
SDTI1-2 Hold Time	tSDH	10			ns
SDTI1-2 Setup Time	tSDS	10			ns

Notes: 18. BICK rising edge must not occur at the same time as LRCK edge.

Parameter	Symbol	min	typ	max	Units
Control Interface Timing (3-wire Serial mode):					
CCLK Period	tCCK	200			ns
CCLK Pulse Width Low	tCCKL	80			ns
Pulse Width High	tCCKH	80			ns
CDTI Setup Time	tCDS	40			ns
CDTI Hold Time	tCDH	40			ns
CSN "H" Time	tCSW	150			ns
CSN "↓" to CCLK "↑"	tCSS	50			ns
CCLK "↑" to CSN "↑"	tCSH	50			ns
Control Interface Timing (I²C Bus mode):					
SCL Clock Frequency	fSCL	-		100	kHz
Bus Free Time Between Transmissions	tBUF	4.7		-	μs
Start Condition Hold Time (prior to first clock pulse)	tHD:STA	4.0		-	μs
Clock Low Time	tLOW	4.7		-	μs
Clock High Time	tHIGH	4.0		-	μs
Setup Time for Repeated Start Condition	tSU:STA	4.7		-	μs
SDA Hold Time from SCL Falling (Note 19)	tHD:DAT	0		-	μs
SDA Setup Time from SCL Rising	tSU:DAT	0.25		-	μs
Rise Time of Both SDA and SCL Lines	tR	-		1.0	μs
Fall Time of Both SDA and SCL Lines	tF	-		0.3	μs
Setup Time for Stop Condition	tSU:STO	4.0		-	μs
Pulse Width of Spike Noise Suppressed by Input Filter	tSP	0		50	ns
Power-down & Reset Timing					
PDN Pulse Width (Note 20)	tPD	150			ns
PDN "↑" to SDTO valid (Note 21)	tPDV		522		1/fs

- Notes: 19. Data must be held for sufficient time to bridge the 300 ns transition time of SCL.
20. The AK4628 can be reset by bringing PDN "L" to "H" upon power-up.
21. These cycles are the number of LRCK rising from PDN rising.
22. I²C is a registered trademark of Philips Semiconductors.

Purchase of Asahi Kasei Microsystems Co., Ltd I²C components conveys a license under the Philips I²C patent to use the components in the I²C system, provided the system conform to the I²C specifications defined by Philips.

■ Timing Diagram

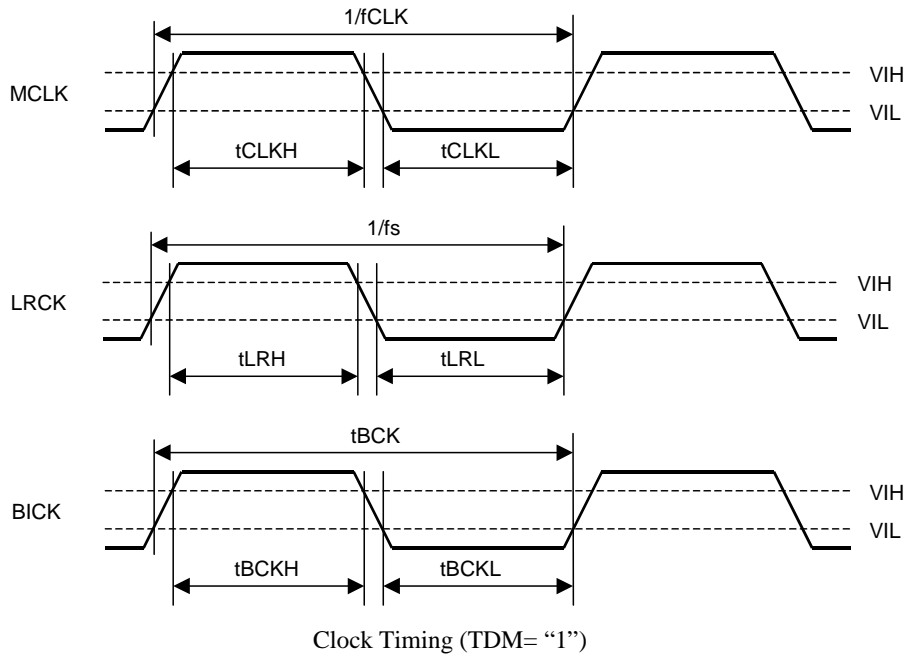
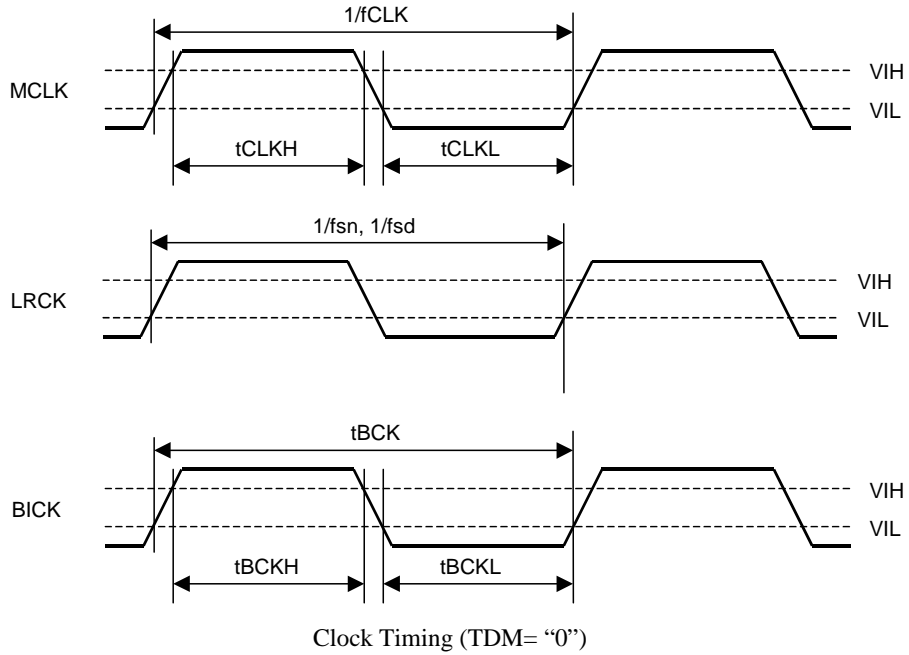

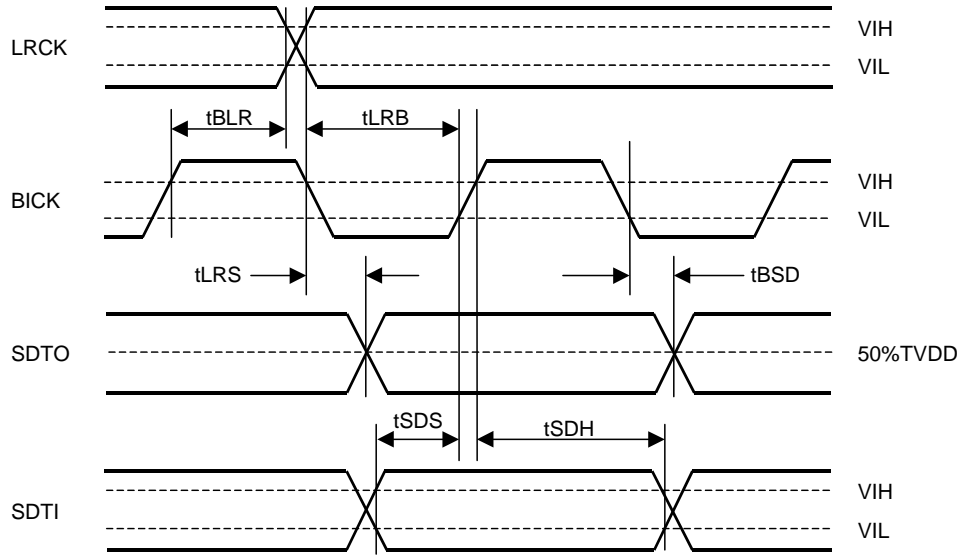

Audio Interface Timing (TDM= "0")

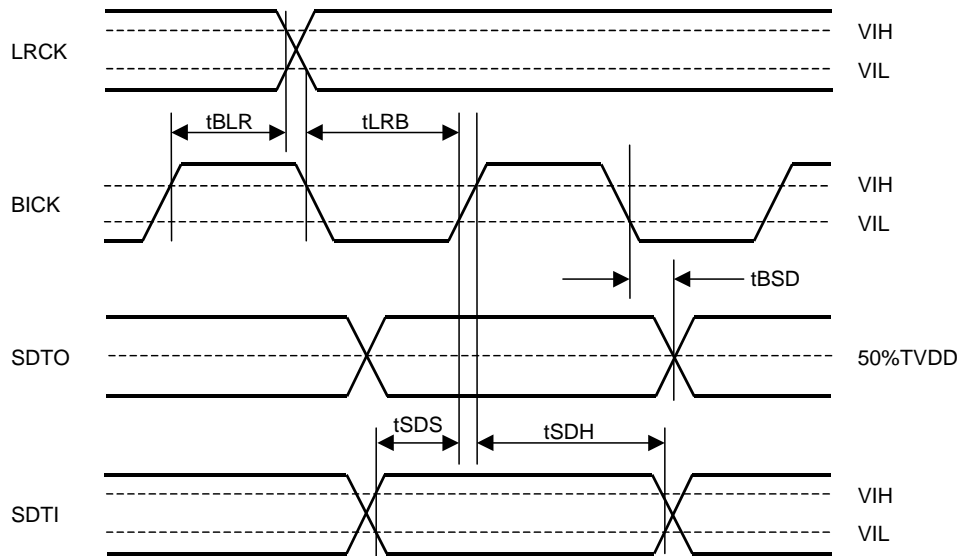

Audio Interface Timing (TDM= "1")

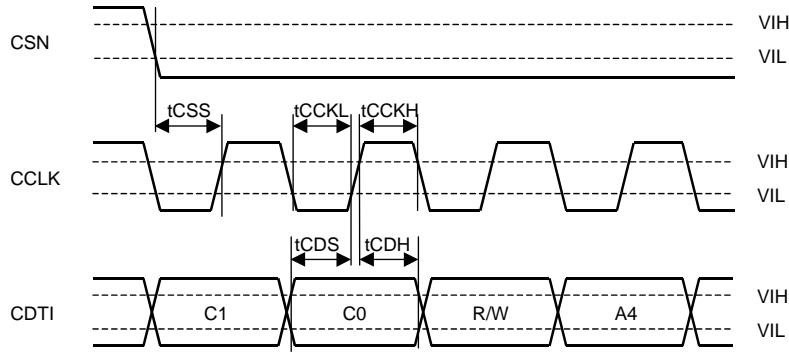

WRITE Command Input Timing (3-wire Serial mode)

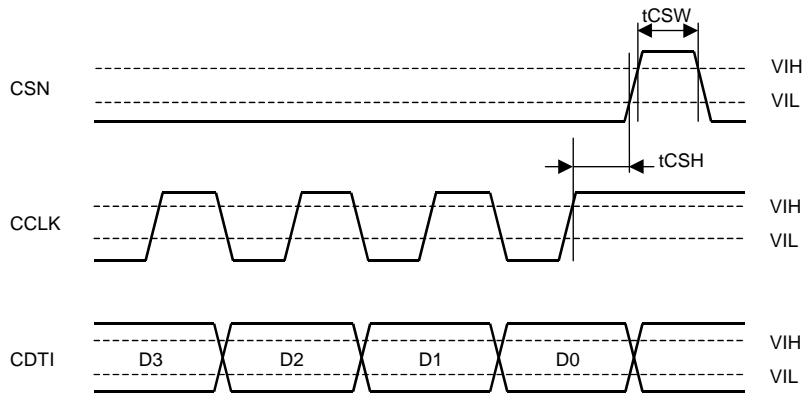

WRITE Data Input Timing (3-wire Serial mode)

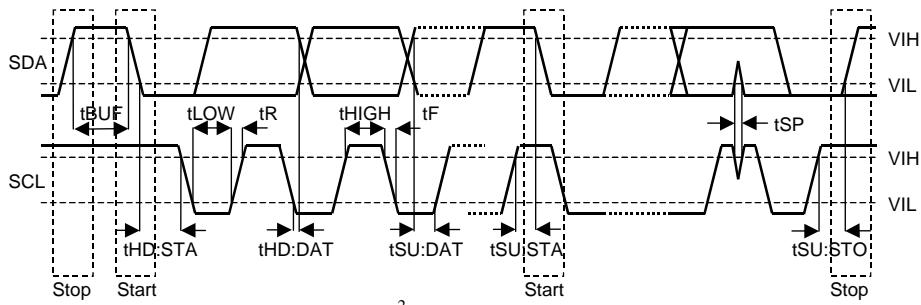

I²C Bus mode Timing

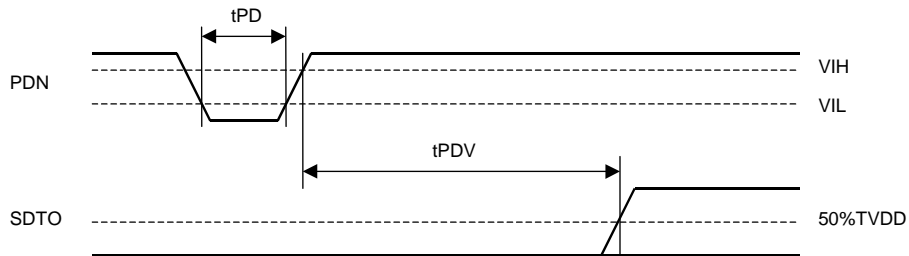

Power-down & Reset Timing

OPERATION OVERVIEW

■ System Clock

The external clocks, which are required to operate the AK4628, are MCLK, LRCK and BICK. MCLK should be synchronized with LRCK but the phase is not critical. There are two methods to set MCLK frequency. In Manual Setting Mode (ACKS = "0": Default), the sampling speed is set by DFS0, DFS1 (Table 1). The frequency of MCLK at each sampling speed is set automatically. (Table 2, 3, 4). In Auto Setting Mode (ACKS = "1"), as MCLK frequency is detected automatically (Table 5), and the internal master clock becomes the appropriate frequency (Table 6), it is not necessary to set DFS.

External clocks (MCLK, BICK) should always be present whenever the AK4628 is in normal operation mode (PDN = "H"). If these clocks are not provided, the AK4628 may draw excess current because the device utilizes dynamic refreshed logic internally. If the external clocks are not present, the AK4628 should be in the power-down mode (PDN = "L") or in the reset mode (RSTN = "0"). After exiting reset at power-up etc., the AK4628 is in the power-down mode until MCLK and LRCK are input.

DFS1	DFS0	Sampling Speed (fs)		Default
0	0	Normal Speed Mode	32kHz~48kHz	
0	1	Double Speed Mode	64kHz~96kHz	
1	0	Quad Speed Mode	120kHz~192kHz	

Table 1. Sampling Speed (Manual Setting Mode)

LRCK	MCLK (MHz)			BICK (MHz)
fs	256fs	384fs	512fs	64fs
32.0kHz	8.1920	12.2880	16.3840	2.0480
44.1kHz	11.2896	16.9344	22.5792	2.8224
48.0kHz	12.2880	18.4320	24.5760	3.0720

Table 2. System Clock Example (Normal Speed Mode @Manual Setting Mode)

LRCK	MCLK (MHz)			BICK (MHz)
fs	128fs	192fs	256fs	64fs
88.2kHz	11.2896	16.9344	22.5792	5.6448
96.0kHz	12.2880	18.4320	24.5760	6.1440

Table 3. System Clock Example (Double Speed Mode @Manual Setting Mode)

(Note: At Double speed mode(DFS1 = "0", DFS0 = "1"), 128fs and 192fs are not available for ADC.)

LRCK	MCLK (MHz)			BICK (MHz)
fs	128fs	192fs	256fs	64fs
176.4kHz	22.5792	-	-	11.2896
192.0kHz	24.5760	-	-	12.2880

Table 4. System Clock Example (Quad Speed Mode @Manual Setting Mode)

(Note: At Quad speed mode(DFS1 = "1", DFS0 = "0") are not available for ADC.)

MCLK	Sampling Speed
512fs	Normal
256fs	Double
128fs	Quad

Table 5. Sampling Speed (Auto Setting Mode)

LRCK fs	MCLK (MHz)			Sampling Speed
	128fs	256fs	512fs	
32.0kHz	-	-	16.3840	Normal
44.1kHz	-	-	22.5792	
48.0kHz	-	-	24.5760	
88.2kHz	-	22.5792	-	Double
96.0kHz	-	24.5760	-	
176.4kHz	22.5792	-	-	Quad
192.0kHz	24.5760	-	-	

Table 6. System Clock Example (Auto Setting Mode)

■ De-emphasis Filter

The AK4628 includes the digital de-emphasis filter ($t_c=50/15\mu s$) by IIR filter. De-emphasis filter is not available in Double Speed Mode and Quad Speed Mode. This filter corresponds to three sampling frequencies (32kHz, 44.1kHz, 48kHz). De-emphasis of each DAC can be set individually by register data of DEMA1-C0 (DAC1: DEMA1-0, DAC2: DEMB1-0, DAC3: DEMC1-0, DAC4: DEMD1-0, see "Register Definitions").

Mode	Sampling Speed	DEM1	DEM0	DEM	Default
0	Normal Speed	0	0	44.1kHz	
1	Normal Speed	0	1	OFF	
2	Normal Speed	1	0	48kHz	
3	Normal Speed	1	1	32kHz	

Table 8. De-emphasis control

■ Digital High Pass Filter

The ADC has a digital high pass filter for DC offset cancel. The cut-off frequency of the HPF is 1.0Hz at $f_s=48kHz$ and scales with sampling rate (f_s).

■ Audio Serial Interface Format

When TDM= “L”, four modes can be selected by the DIF1-0 as shown in Table 8. In all modes the serial data is MSB-first, 2’s compliment format. The SDTO is clocked out on the falling edge of BICK and the SDTI/DAUX are latched on the rising edge of BICK.

Figures 1~4 shows the timing at SDOS = “L”. In this case, the SDTO outputs the ADC output data. When SDOS = “H”, the data input to DAUX is converted to SDTO’s format and output from SDTO. Mode 2, 3, 6, 7, 10, 11 in SDTI input formats can be used for 16-20bit data by zeroing the unused LSBs.

Mode	TDM 1	TDM0	DIF1	DIF0	SDTO	SDTI1-4, DAUX	LRCK		BICK	
								I/O		I/O
0	0	0	0	0	24bit, Left justified	20bit, Right justified	H/L	I	≥ 48fs	I
1	0	0	0	1	24bit, Left justified	24bit, Right justified	H/L	I	≥ 48fs	I
2	0	0	1	0	24bit, Left justified	24bit, Left justified	H/L	I	≥ 48fs	I
3	0	0	1	1	24bit, I ² S	24bit, I ² S	L/H	I	≥ 48fs	I

Default

Table 8. Audio data formats (Normal mode)

The audio serial interface format becomes the TDM mode if TDM0 pin is set to “H”. In the TDM256 mode, the serial data of all DAC (eight channels) is input to the SDTI1 pin. The input data to SDTI2-4 pins are ignored. BICK should be fixed to 256fs. “H” time and “L” time of LRCK should be 1/256fs at least. Four modes can be selected by the DIF1-0 as shown in Table 9. In all modes the serial data is MSB-first, 2’s compliment format. The SDTO is clocked out on the falling edge of BICK and the SDTI1 are latched on the rising edge of BICK. SDOS and LOOP1-0 should be set to “0” at the TDM mode. TDM128 Mode can be set by TDM1 as show in Table10. In Double Speed Mode, the serial data of DAC (four channels; L1, R1, L2, R2) is input to the SDTI1 pin. Other four data (L3, R3, L4, R4) are input to the SDTI2. TDM0 pin and TDM0 register should be set to “H” if TDM256 Mode is selected. TDM0 pin and TDM0 register, TDM1 register should be set to “H” if Double Speed Mode is selected in TDM128 Mode.

Mode	TDM 1	TDM0	DIF1	DIF0	SDTO	SDTI1	LRCK		BICK	
								I/O		I/O
4	0	1	0	0	24bit, Left justified	20bit, Right justified	↑	I	256fs	I
5	0	1	0	1	24bit, Left justified	24bit, Right justified	↑	I	256fs	I
6	0	1	1	0	24bit, Left justified	24bit, Left justified	↑	I	256fs	I
7	0	1	1	1	24bit, I ² S	24bit, I ² S	↓	I	256fs	I

Table 9. Audio data formats (TDM256 mode)

Mode	TDM 1	TDM0	DIF1	DIF0	SDTO	SDTI1, SDTI2	LRCK		BICK	
								I/O		I/O
8	1	1	0	0	24bit, Left justified	20bit, Right justified	↑	I	128fs	I
9	1	1	0	1	24bit, Left justified	24bit, Right justified	↑	I	128fs	I
10	1	1	1	0	24bit, Left justified	24bit, Left justified	↑	I	128fs	I
11	1	1	1	1	24bit, I ² S	24bit, I ² S	↓	I	128fs	I

Table 10. Audio data formats (TDM128 mode)

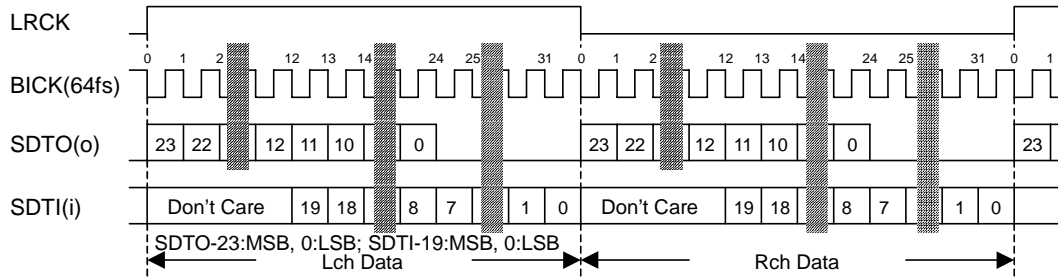

Figure 1. Mode 0 Timing

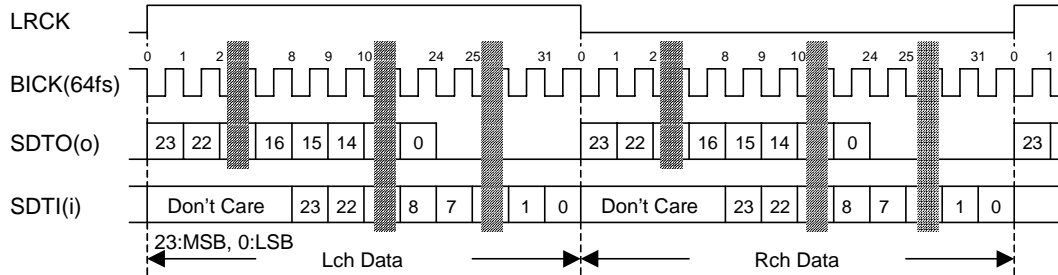

Figure 2. Mode 1 Timing

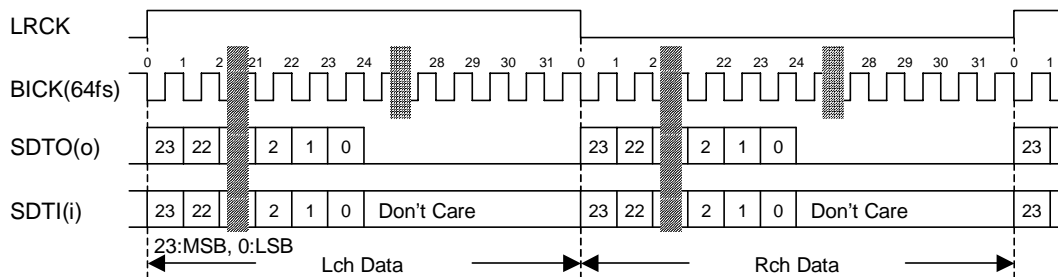

Figure 3. Mode 2 Timing

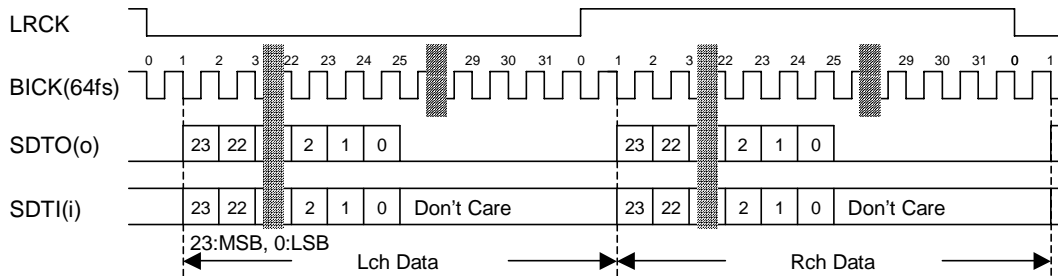

Figure 4. Mode 3 Timing

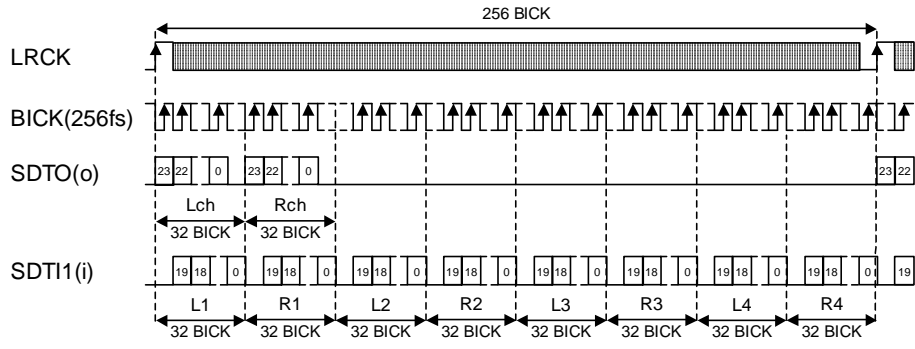

Figure 5. Mode 4 Timing

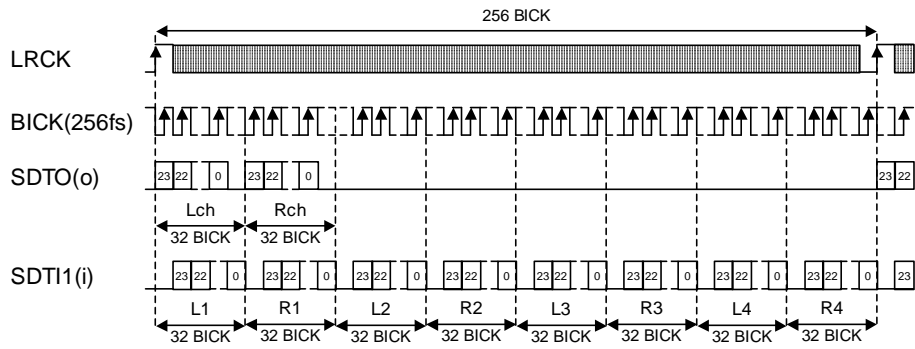

Figure 6. Mode 5 Timing

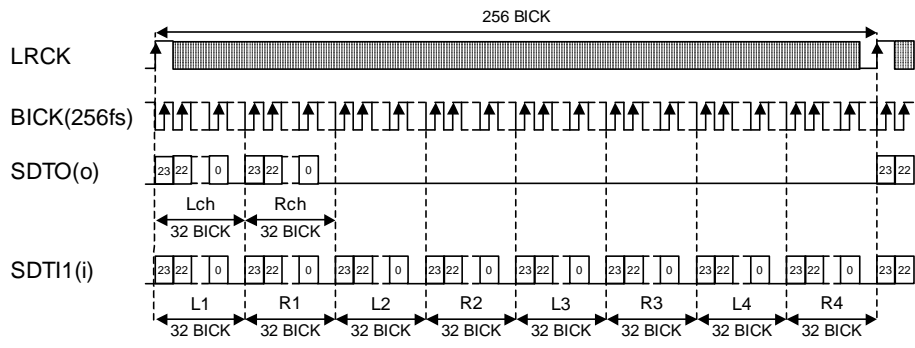

Figure 7. Mode 6 Timing

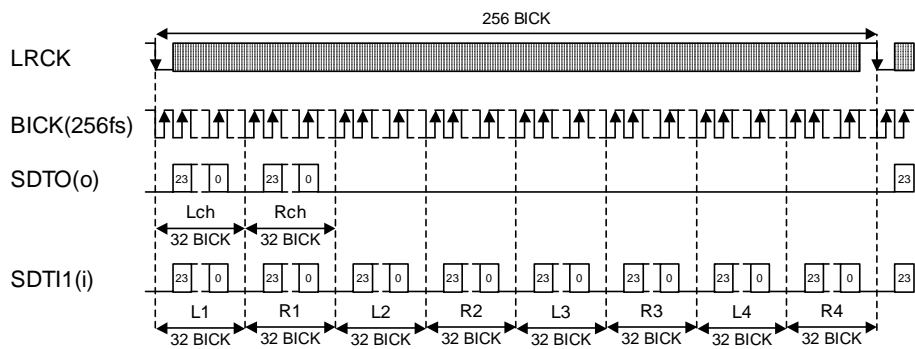

Figure 8. Mode 7 Timing

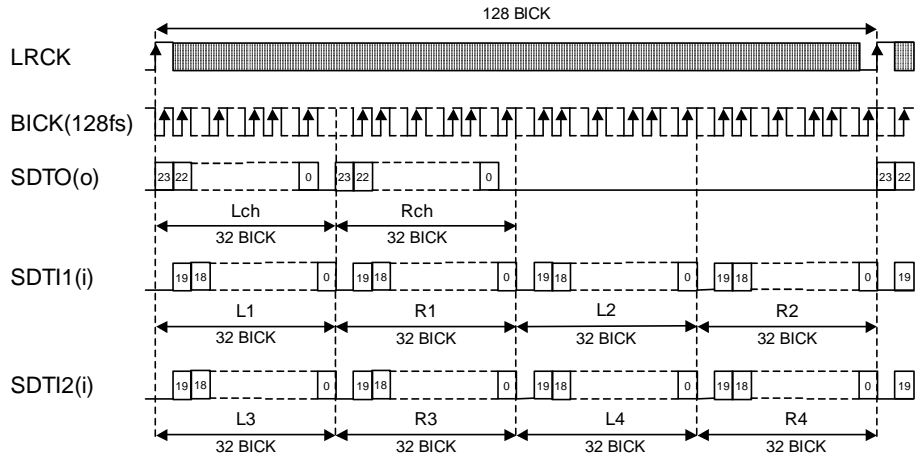

Figure 9. Mode 8 Timing

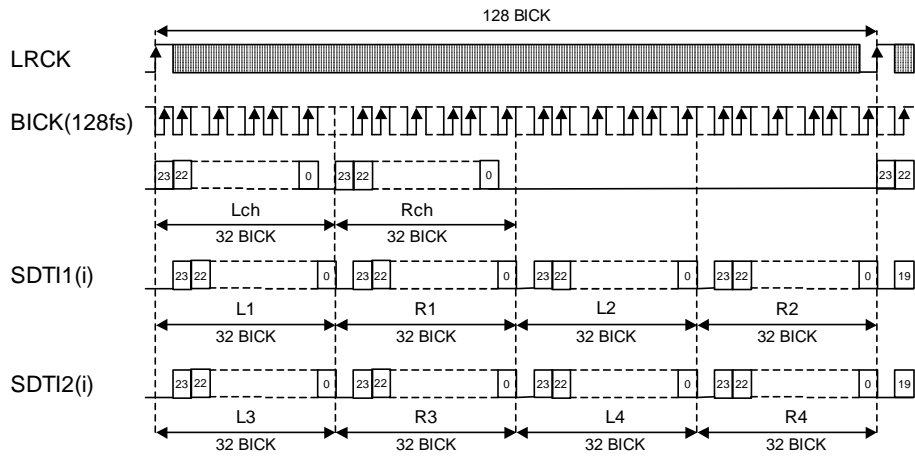

Figure 10. Mode 9 Timing

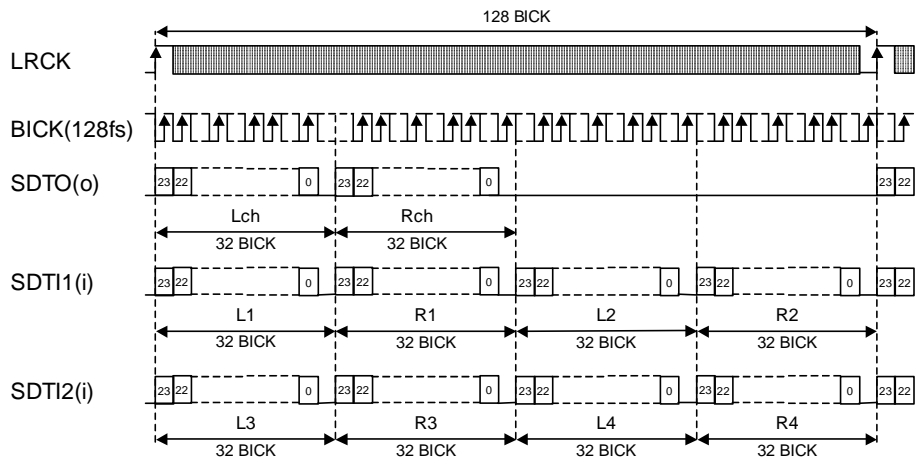

Figure 11. Mode 10 Timing

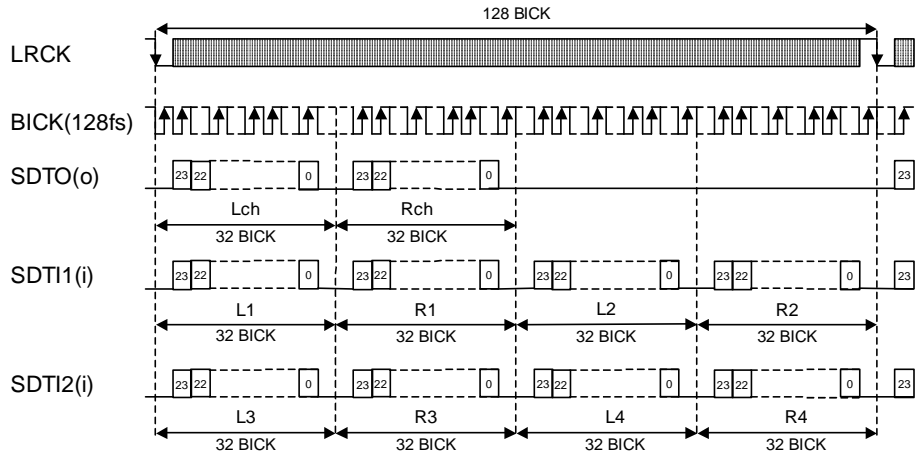

Figure 12. Mode 11 Timing

■ **Overflow Detection**

The AK4628 has overflow detect function for analog input. Overflow detect function is enable if OVFE bit is set to “1” at serial control mode. OVF pin goes to “H” if analog input of Lch or Rch overflows (more than -0.3dBFS). OVF output for overflowed analog input has the same group delay as ADC ($GD = 16/fs = 333\mu s$ @ $fs=48kHz$). OVF is “L” for $522/fs$ ($=11.8ms$ @ $fs=48kHz$) after PDN = “↑”, and then overflow detection is enabled.

■ **Zero Detection**

The AK4628 has two pins for zero detect flag outputs. Channel grouping can be selected by DZFM3-0 bits if P/S = “L” and DZFE = “L” (Table 11). DZF1 pin corresponds to the group 1 channels and DZF2 pin corresponds to the group 2 channels. However DZF2 pin becomes OVF pin if OVFE bit is set to “1”. Zero detection mode is set to mode 0 if DZFE= “H” regardless of P/S pin. DZF1 is AND of all eight channels and DZF2 is disabled (“L”) at mode 0. Table 12 shows the relation of P/S, DZFE, OVFE and DZF.

When the input data of all channels in the group 1(group 2) are continuously zeros for 8192 LRCK cycles, DZF1(DZF2) pin goes to “H”. DZF1(DZF2) pin immediately goes to “L” if input data of any channels in the group 1(group 2) is not zero after going DZF1(DZF2) “H”.

Mode	DZFM				AOUT									
	3	2	1	0	L1	R1	L2	R2	L3	R3	L4	R4		
0	0	0	0	0	DZF1	DZF1	DZF1	DZF1	DZF1	DZF1	DZF1	DZF1	DZF1	
1	0	0	0	1	DZF1	DZF1	DZF1	DZF1	DZF1	DZF1	DZF2	DZF2	DZF2	
2	0	0	1	0	DZF1	DZF1	DZF1	DZF1	DZF2	DZF2	DZF2	DZF2	DZF2	
3	0	0	1	1	DZF1	DZF1	DZF1	DZF2	DZF2	DZF2	DZF2	DZF2	DZF2	
4	0	1	0	0	DZF1	DZF1	DZF2	DZF2	DZF2	DZF2	DZF2	DZF2	DZF2	
5	0	1	0	1	DZF1	DZF2	DZF2	DZF2	DZF2	DZF2	DZF2	DZF2	DZF2	
6	0	1	1	0	DZF2	DZF2	DZF2	DZF2	DZF2	DZF2	DZF2	DZF2	DZF2	
7	0	1	1	1	disable (DZF1=DZF2 = “L”)								Default	
8	1	0	0	0	DZF1	DZF1	DZF1	DZF1	DZF1	DZF1	DZF1	DZF1	DZF2	
9	1	0	0	1	DZF1	DZF1	DZF1	DZF1	DZF1	DZF1	DZF1	DZF2	DZF2	
10	1	0	1	0	disable (DZF1=DZF2 = “L”)									
11	1	0	1	1										
12	1	1	0	0										
13	1	1	0	1										
14	1	1	1	0										
15	1	1	1	1										

Table 11. Zero detect control

P/S pin	DZFE pin	OVFE bit	DZF mode	DZF1 pin	DZF2/OVF pin
“H” (parallel mode)	“L”	disable	Mode 7	“L”	“L”
	“H”	disable	Mode 0	AND of 6ch	“L”
“L” (serial mode)	“L”	“0”	Selectable	Selectable	Selectable
		“1”	Selectable	Selectable	OVF output
	“H”	“0”	Mode 0	AND of 6ch	“L”
		“1”	Mode 0	AND of 6ch	OVF output

Table 12. DZF1-2 pins outputs

■ Digital Attenuator

AK4628 has channel-independent digital attenuator (128 levels, 0.5dB step). Attenuation level of each channel can be set by each ATT7-0 bits (Table 13).

ATT7-0	Attenuation Level
00H	0dB
01H	-0.5dB
02H	-1.0dB
:	:
7DH	-62.5dB
7EH	-63dB
7FH	MUTE ($-\infty$)
:	:
FEH	MUTE ($-\infty$)
FFH	MUTE ($-\infty$)

Default

Table 13. Attenuation level of digital attenuator

Transition time between set values of ATT7-0 bits can be selected by ATS1-0 bits (Table 14). Transition between set values is the soft transition. Therefore, the switching noise does not occur in the transition.

Mode	ATS1	ATS0	ATT speed
0	0	0	1792/fs
1	0	1	896/fs
2	1	0	256/fs
3	1	1	256/fs

Default

Table 14. Transition time between set values of ATT7-0 bits

The transition between set values is soft transition of 1792 levels in mode 0. It takes 1792/fs (37.3ms@fs=48kHz) from 00H(0dB) to 7FH(MUTE) in mode 0. If PDN pin goes to "L", the ATTs are initialized to 00H. The ATTs are 00H when RSTN = "0". When RSTN return to "1", the ATTs fade to their current value.

■ Soft mute operation

Soft mute operation is performed at digital domain. When the SMUTE pin goes to “H”, the output signal is attenuated by $-\infty$ during $ATT_DATA \times ATT$ transition time (Table 14) from the current ATT level. When the SMUTE pin is returned to “L”, the mute is cancelled and the output attenuation gradually changes to the ATT level during $ATT_DATA \times ATT$ transition time. If the soft mute is cancelled before attenuating to $-\infty$ after starting the operation, the attenuation is discontinued and returned to ATT level by the same cycle. The soft mute is effective for changing the signal source without stopping the signal transmission.

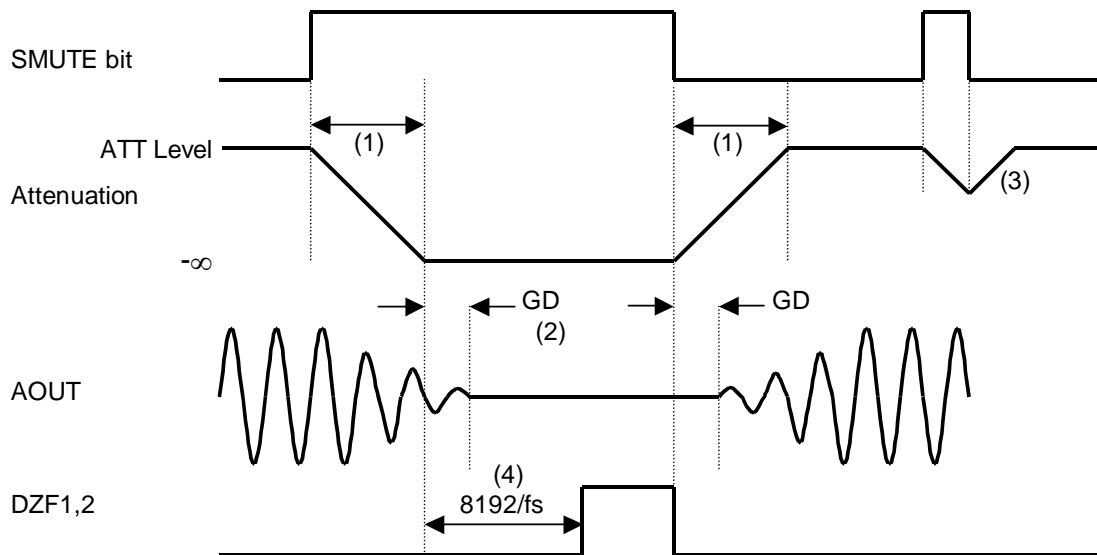

Notes:

- (1) $ATT_DATA \times ATT$ transition time (Table 16). For example, in Normal Speed Mode, this time is 1792LRCK cycles (1792/fs) at $ATT_DATA=00H$. ATT transition of the soft-mute is from 00H to 7FH
- (2) The analog output corresponding to the digital input has a group delay, GD.
- (3) If the soft mute is cancelled before attenuating to $-\infty$ after starting the operation, the attenuation is discontinued and returned to ATT level by the same cycle.
- (4) When the input data at all the channels of the group are continuously zeros for 8192 LRCK cycles, DZF pin of each channel goes to “H”. DZF pin immediately goes to “L” if the input data of either channel of the group are not zero after going DZF “H”.

Figure 13. Soft mute and zero detection

■ System Reset

The AK4628 should be reset once by bringing $PDN = “L”$ upon power-up. The AK4628 is powered up and the internal timing starts clocking by LRCK “↑” after exiting reset and power down state by MCLK. The AK4628 is in the power-down mode until MCLK and LRCK are input.

■ Power-Down

The ADC and DACs of AK4628 are placed in the power-down mode by bringing PDN “L” and both digital filters are reset at the same time. PDN “L” also reset the control registers to their default values. In the power-down mode, the analog outputs go to VCOM voltage and DZF1-2 pins go to “L”. This reset should always be done after power-up. In case of the ADC, an analog initialization cycle starts after exiting the power-down mode. Therefore, the output data, SDTO becomes available after 522 cycles of LRCK clock. In case of the DAC, an analog initialization cycle starts after exiting the power-down mode. The analog outputs are VCOM voltage during the initialization. Figure 14 shows the sequences of the power-down and the power-up.

The ADC and all DACs can be powered-down individually by PWADN and PWDAN bits. And DAC1-4 can be power-down individually by PD1-4 bits. In this case, the internal register values are not initialized. When PWADN = “0”, SDTO goes to “L”. When PWDAN = “0” and PD1-4 = “0”, the analog outputs go to VCOM voltage and DZF1-2 pins go to “H”. Because some click noise occurs, the analog output should muted externally if the click noise influences system application.

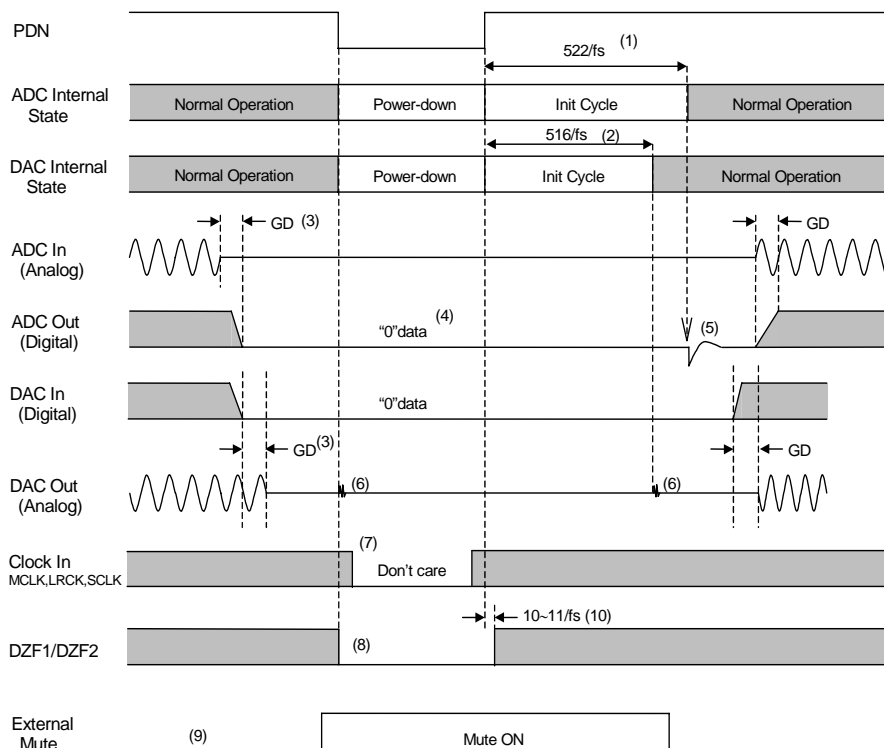

Notes:

- (1) The analog part of ADC is initialized after exiting the power-down state.
- (2) The analog part of DAC is initialized after exiting the power-down state.
- (3) Digital output corresponding to analog input and analog output corresponding to digital input have the group delay (GD).
- (4) ADC output is “0” data at the power-down state.
- (5) Click noise occurs at the end of initialization of the analog part. Please mute the digital output externally if the click noise influences system application.
- (6) Click noise occurs at the falling edge of PDN and at 512/fs after the rising edge of PDN.
- (7) When the external clocks (MCLK, BICK and LRCK) are stopped, the AK4628 should be in the power-down mode.
- (8) DZF pins are “L” in the power-down mode (PDN = “L”).
- (9) Please mute the analog output externally if the click noise (6) influences system application.
- (10) DZF= “L” for 10~11/fs after PDN= “↑”.

Figure 14. Power-down/up sequence example

Reset Function

When RSTN = "0", ADC and DACs are powered-down but the internal register are not initialized. The analog outputs go to VCOM voltage, DZF1-2 pins go to "H" and SDTO pin goes to "L". Because some click noise occurs, the analog output should muted externally if the click noise influences system application. Figure 15 shows the power-up sequence.

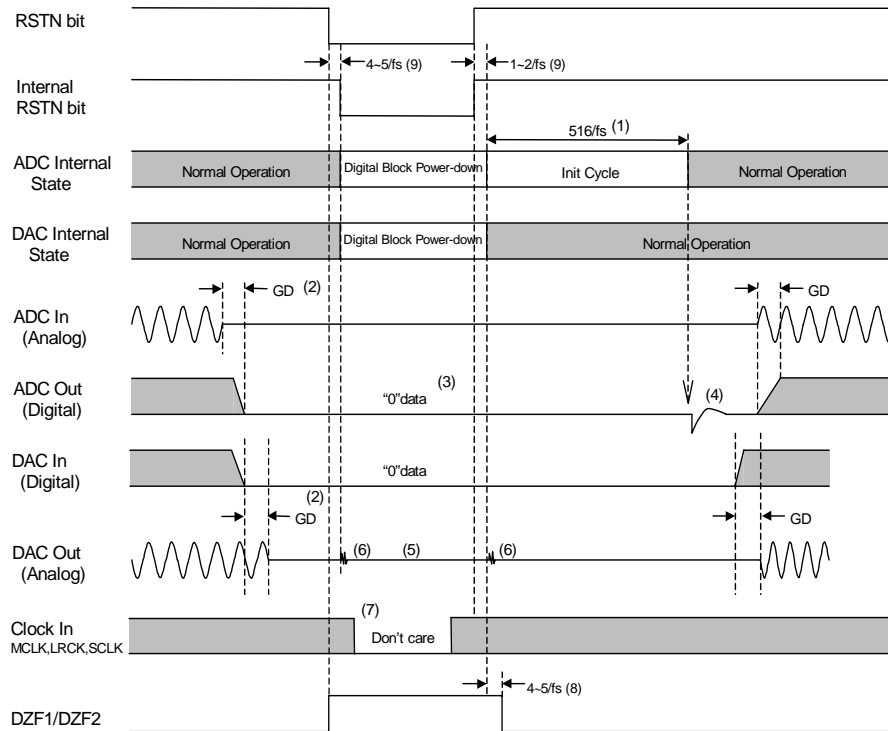

Notes:

- (1) The analog part of ADC is initialized after exiting the reset state.
- (2) Digital output corresponding to analog input and analog output corresponding to digital input have the group delay (GD).
- (3) ADC output is "0" data at the power-down state.
- (4) Click noise occurs when the internal RSTN bit becomes "1". Please mute the digital output externally if the click noise influences system application.
- (5) The analog outputs go to VCOM voltage.
- (6) Click noise occurs at $4\sim 5/f_s$ after RSTN bit becomes "0", and occurs at $1\sim 2/f_s$ after RSTN bit becomes "1". This noise is output even if "0" data is input.
- (7) The external clocks (MCLK, BICK and LRCK) can be stopped in the reset mode. When exiting the reset mode, "1" should be written to RSTN bit after the external clocks (MCLK, BICK and LRCK) are fed.
- (8) DZF pins go to "H" when the RSTN bit becomes "0", and go to "L" at $6\sim 7/f_s$ after RSTN bit becomes "1".
- (9) There is a delay, $4\sim 5/f_s$ from RSTN bit "0" to the internal RSTN bit "0".

Figure 15. Reset sequence example

■ DAC partial Power-Down Function

All DACs of AK4628 can be powered-down individually by PD1-4 bits. The analog part of DAC is in power-down by PD1-4 bits = "1", however, the digital part is not in power-down by it. Even if all DACs were set in power-down by the partial power-down bits, the digital part continue to function. The analog output of the channel which is set in power-down by PD1-4 bits is fixed to the voltage of VCOM. And though DZF detection is being done, the result of DZF detection stops reflecting to DZF1-2 pins. Because some click noise occurs in both set-up and release of power-down, either the analog output should be muted externally or PD1-4 bits should be set up when it is in PWDAN bit = "0" or RSTN bit = "0", if the click noise influences system application. Figure 16 shows the sequence of the power-down and the power-up by PD1-4 bits.

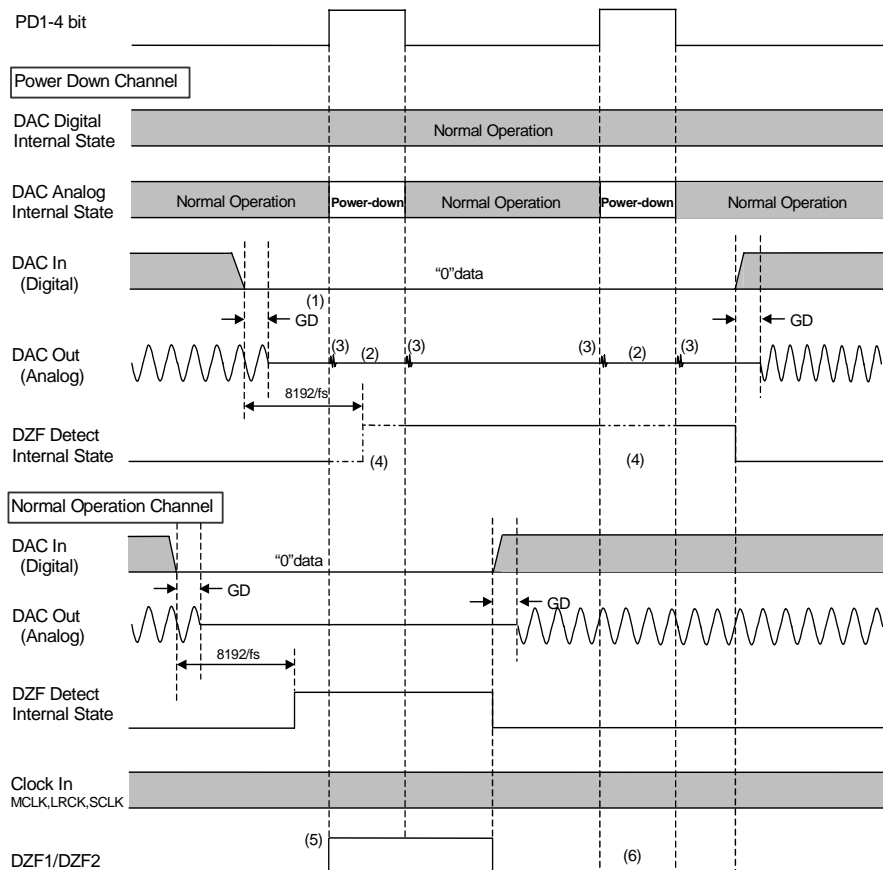

Notes:

- (1) Digital output corresponding to analog input and analog output corresponding to digital input have the group delay (GD).
- (2) Analog output of the DAC powered down by PD1-4 = "1" is fixed to the voltage of VCOM.
- (3) Immediately after PD1-4 bits are changed, some click noise occurs at the output of the channel changed by the own PD bits.
- (4) Though DZF detection is being done at a certain channel which set up PD1-4 = "1", the result of DZF detection stops reflecting to DZF1-2 pins.
- (5) DZF detection of the DAC which is set up by the power-down setting is ignored, and DZF1-2 pins become "H".
- (6) When the power-down function is set up and the channel has input signal, even if the partial power-down function is set up, DZF1-2 bits do not become "H".

Figure 16. DAC partial power-down example

■ Serial Control Interface

The AK4628 can control its functions via registers. Internal registers may be written by 2 types of control mode. The chip address is determined by the state of the CAD0 and CAD1 inputs. PDN = “L” initializes the registers to their default values. Writing “0” to the RSTN bit can initialize the internal timing circuit. But in this case, the register data is not be initialized. When the state of P/S pin is changed, the AK4628 should be reset by PDN pin.

- * Writing to control register is invalid when PDN = “L”.
- * AK4628 does not support the read command.

(1) 3-wire Serial Control Mode (I2C = “L”)

Internal registers may be written to the 3 wire μ P interface pins (CSN, CCLK and CDTI). The data on this interface consists of Chip address (2bits, CAD0/1), Read/Write (1bit, Fixed to “1”, Write only), Register address (MSB first, 5bits) and Control data (MSB first, 8bits). Address and data is clocked in on the rising edge of CCLK and data is clocked out on the falling edge. For write operations, data is latched after a low-to-high transition of CSN. The clock speed of CCLK is 5MHz(max).

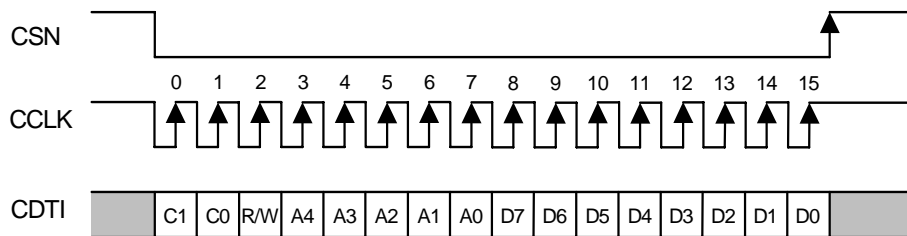

C1-C0: Chip Address (C1=CAD1, C0=CAD0)
 R/W: Read/Write (Fixed to “1”, Write only)
 A4-A0: Register Address
 D7-D0: Control Data

Figure 17. 3-wire Serial Control I/F Timing

(2) I²C-bus Control Mode (I2C= "H")

AK4628 supports the standard-mode I²C-bus (max:100kHz). Then AK4628 does not support a fast-mode I²C-bus system (max:400kHz). The CSN pin should be connected to DVDD at the I²C-bus mode.

Figure 17 shows the data transfer sequence at the I²C-bus mode. All commands are preceded by a START condition. A HIGH to LOW transition on the SDA line while SCL is HIGH indicates a START condition (Figure 22). After the START condition, a slave address is sent. This address is 7 bits long followed by an eighth bit which is a data direction bit (R/W) (Figure 19). The most significant five bits of the slave address are fixed as "00100". The next two bits are CAD1 and CAD0 (device address bits). These two bits identify the specific device on the bus. The hard-wired input pins (CAD1 pin and CAD0 pin) set them. If the slave address match that of the AK4628 and R/W bit is "0", the AK4628 generates the acknowledge and the write operation is executed. If R/W bit is "1", the AK4628 generates the not acknowledge since the AK4628 can be only a slave-receiver. The master must generate the acknowledge-related clock pulse and release the SDA line (HIGH) during the acknowledge clock pulse (Figure 23).

The second byte consists of the address for control registers of the AK4628. The format is MSB first, and those most significant 3-bits are fixed to zeros (Figure 20). Those data after the second byte contain control data. The format is MSB first, 8bits (Figure 21). The AK4628 generates an acknowledge after each byte has been received. A data transfer is always terminated by a STOP condition generated by the master. A LOW to HIGH transition on the SDA line while SCL is HIGH defines a STOP condition (Figure 22).

The AK4628 is capable of more than one byte write operation by one sequence. After receipt of the third byte, the AK4628 generates an acknowledge, and awaits the next data again. The master can transmit more than one byte instead of terminating the write cycle after the first data byte is transferred. After the receipt of each data, the internal 5bits address counter is incremented by one, and the next data is taken into next address automatically. If the address exceed 1FH prior to generating the stop condition, the address counter will "roll over" to 00H and the previous data will be overwritten.

The data on the SDA line must be stable during the HIGH period of the clock. The HIGH or LOW state of the data line can only change when the clock signal on the SCL line is LOW (Figure 24) except for the START and the STOP condition.

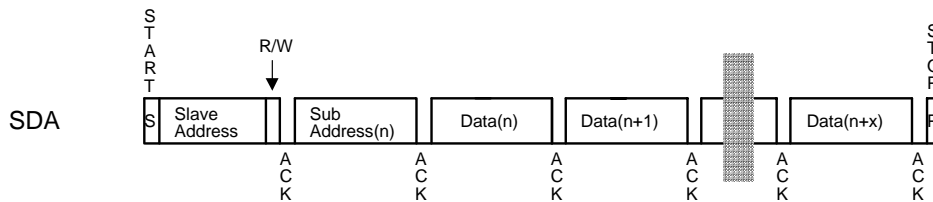

Figure 18. Data transfer sequence at the I²C-bus mode

0	0	1	0	0	CAD1	CAD0	R/W
---	---	---	---	---	------	------	-----

(Those CAD1/0 should match with CAD1/0 pins)

Figure 19. The first byte

*	*	*	A4	A3	A2	A1	A0
---	---	---	----	----	----	----	----

(*: Don't care)

Figure 20. The second byte

D7	D6	D5	D4	D3	D2	D1	D0
----	----	----	----	----	----	----	----

Figure 21. Byte structure after the second byte

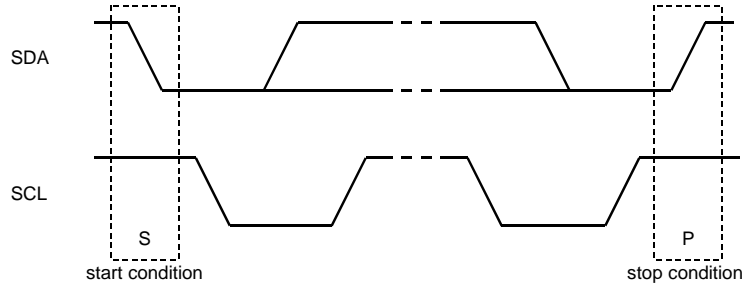

Figure 22. START and STOP conditions

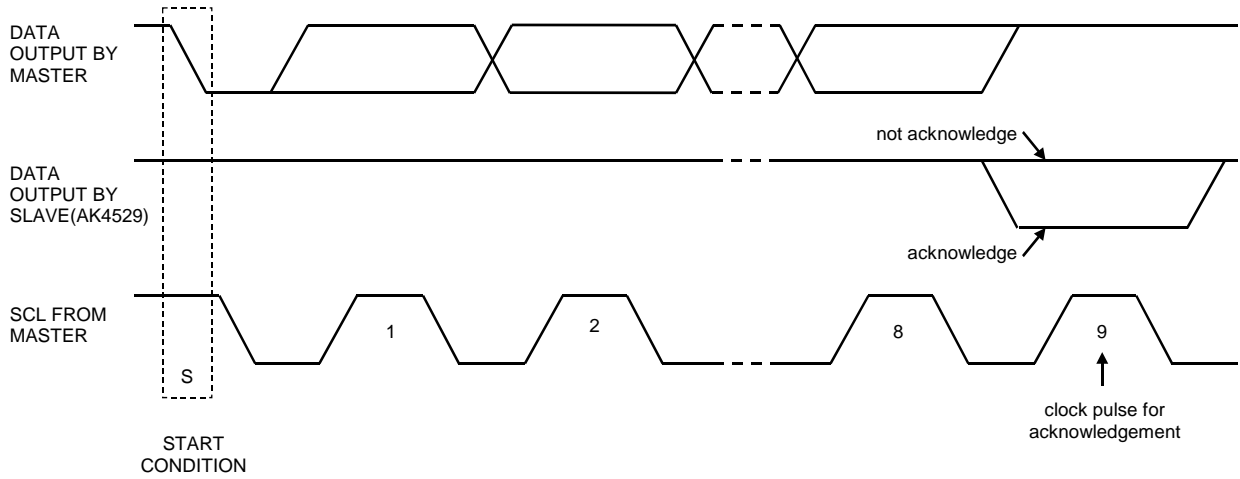

Figure 23. Acknowledge on the I²C-bus

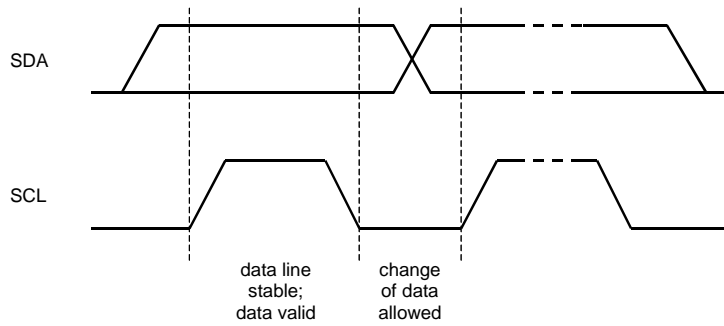

Figure 24. Bit transfer on the I²C-bus

■ Mapping of Program Registers

Addr	Register Name	D7	D6	D5	D4	D3	D2	D1	D0
00H	Control 1	0	0	TDM1	TDM0	DIF1	DIF0	0	SMUTE
01H	Control 2	0	DFS1	LOOP1	LOOP0	SDOS	DFS0	ACKS	0
02H	LOUT1 Volume Control	ATT7	ATT6	ATT5	ATT4	ATT3	ATT2	ATT1	ATT0
03H	ROUT1 Volume Control	ATT7	ATT6	ATT5	ATT4	ATT3	ATT2	ATT1	ATT0
04H	LOUT2 Volume Control	ATT7	ATT6	ATT5	ATT4	ATT3	ATT2	ATT1	ATT0
05H	ROUT2 Volume Control	ATT7	ATT6	ATT5	ATT4	ATT3	ATT2	ATT1	ATT0
06H	LOUT3 Volume Control	ATT7	ATT6	ATT5	ATT4	ATT3	ATT2	ATT1	ATT0
07H	ROUT3 Volume Control	ATT7	ATT6	ATT5	ATT4	ATT3	ATT2	ATT1	ATT0
08H	De-emphasis	DEMD1	DEMD0	DEMA1	DEMA0	DEMB1	DEMB0	DEMC1	DEMC0
09H	ATT speed & Power Down Control	0	PD4	ATS1	ATS0	PD3	PD2	PD1	RSTN
0AH	Zero detect	OVFE	DZFM3	DZFM2	DZFM1	DZFM0	PWVRN	PWADN	PWDAN
0BH	LOUT4 Volume Control	ATT7	ATT6	ATT5	ATT4	ATT3	ATT2	ATT1	ATT0
0CH	ROUT4 Volume Control	ATT7	ATT6	ATT5	ATT4	ATT3	ATT2	ATT1	ATT0

Note: For addresses from 0DH to 1FH, data is not written.

When PDN goes to “L”, the registers are initialized to their default values.

When RSTN bit goes to “0”, the internal timing is reset and DZF1-2 pins go to “H”, but registers are not initialized to their default values.

SMUTE, DFS0, SDOS and TDM0 are ORed with pins.

■ Register Definitions

Addr	Register Name	D7	D6	D5	D4	D3	D2	D1	D0
00H	Control 1	0	0	TDM1	TDM0	DIF1	DIF0	0	SMUTE
	Default	0	0	0	0	1	0	0	0

SMUTE: Soft Mute Enable

0: Normal operation

1: All DAC outputs soft-muted

Register bit of SMUTE is ORed with the SMUTE pin if P/S = "L".

DIF1-0: Audio Data Interface Modes (see Table 8, 9, 10)

Initial: "10", mode 2

TDM1-0: TDM Format Select (see Table 8, 9, 10)

Mode	TDM1	TDM0	SDTI	Sampling Speed
0	0	0	1-4	Normal, Double, Four Times Speed
1	0	1	1	Normal Speed
2	1	1	1-2	Normal, Double Speed

Register bit of TDM0 is ORed with the TDM0 pin if P/S = "L".

TDM0 pin should be "L" if the register control is used.

Addr	Register Name	D7	D6	D5	D4	D3	D2	D1	D0
01H	Control 2	0	DFS1	LOOP1	LOOP0	SDOS	DFS0	ACKS	0
	Default	0	0	0	0	0	0	0	0

ACKS: Master Clock Frequency Auto Setting Mode Enable

0: Disable, Manual Setting Mode

1: Enable, Auto Setting Mode

Master clock frequency is detected automatically at ACKS bit "1". In this case, the setting of DFS are ignored. When this bit is "0", DFS0, 1 set the sampling speed mode.

DFS1-0: Sampling speed mode (see Table 1.)

Register bit of DFS0 is ORed with DFS0 pin if P/S = "L".

The setting of DFS is ignored at ACKS bit "1".

SDOS: SDTO source select

0: ADC

1: DAUX

Register bit of SDOS is ORed with SDOS pin if P/S = "L".

SDOS should be set to "0" at TDM bit "1".

In the case of PWADN="0" and PWDAN="0", the setting of SDOS becomes invalid. And ADC is selected.

The output of SDTO becomes "L" at PWADN="0".

LOOP1-0: Loopback mode enable

00: Normal (No loop back)

01: LIN → LOUT1, LOUT2, LOUT3, LOUT4

RIN → ROUT1, ROUT2, ROUT3, ROUT4

The digital ADC output (DAUX input if SDOS = "1") is connected to the digital DAC input. In this mode, the input DAC data to SDTI1-3 is ignored. The audio format of SDTO at loopback mode becomes mode 2 at mode 0, and mode 3 at mode 1, respectively.

10: SDTI1(L) → SDTI2(L), SDTI3(L), SDTI4(L)

SDTI1(R) → SDTI2(R), SDTI3(R), SDTI4(R)

In this mode the input DAC data to SDTI2-4 is ignored.

11: N/A

LOOP1-0 should be set to "00" at TDM bit "1".

In the case of PWADN="0" and PWDAN="0", the setting of LOOP1-0 becomes invalid. And ADC is selected.

And it becomes the normal operation (No loop back).

Addr	Register Name	D7	D6	D5	D4	D3	D2	D1	D0
02H	LOUT1 Volume Control	ATT7	ATT6	ATT5	ATT4	ATT3	ATT2	ATT1	ATT0
03H	ROUT1 Volume Control	ATT7	ATT6	ATT5	ATT4	ATT3	ATT2	ATT1	ATT0
04H	LOUT2 Volume Control	ATT7	ATT6	ATT5	ATT4	ATT3	ATT2	ATT1	ATT0
05H	ROUT2 Volume Control	ATT7	ATT6	ATT5	ATT4	ATT3	ATT2	ATT1	ATT0
06H	LOUT3 Volume Control	ATT7	ATT6	ATT5	ATT4	ATT3	ATT2	ATT1	ATT0
07H	ROUT3 Volume Control	ATT7	ATT6	ATT5	ATT4	ATT3	ATT2	ATT1	ATT0
0BH	LOUT4 Volume Control	ATT7	ATT6	ATT5	ATT4	ATT3	ATT2	ATT1	ATT0
0CH	ROUT4 Volume Control	ATT7	ATT6	ATT5	ATT4	ATT3	ATT2	ATT1	ATT0
Default		0	0	0	0	0	0	0	0

ATT7-0: Attenuation Level (see Table 13.)

Addr	Register Name	D7	D6	D5	D4	D3	D2	D1	D0
08H	De-emphasis	DEMD1	DEMD0	DEMA1	DEMA0	DEMB1	DEMB0	DEMC1	DEMC0
Default		0	1	0	1	0	1	0	1

DEMA1-0: De-emphasis response control for DAC1 data on SDTI1 (see Table 7.)
Initial: "01", OFF

DEMB1-0: De-emphasis response control for DAC2 data on SDTI2 (see Table 7.)
Initial: "01", OFF

DEMC1-0: De-emphasis response control for DAC3 data on SDTI3 (see Table 7.)
Initial: "01", OFF

DEMD1-0: De-emphasis response control for DAC4 data on SDTI4 (see Table 7.)
Initial: "01", OFF

Addr	Register Name	D7	D6	D5	D4	D3	D2	D1	D0
09H	ATT speed & Power Down Control	0	PD4	ATS1	ATS0	PD3	PD2	PD1	RSTN
Default		0	0	0	0	0	0	0	1

RSTN: Internal timing reset

0: Reset. DZF1-2 pins go to "H", but registers are not initialized.

1: Normal operation

ATS1-0: Digital attenuator transition time setting (see Table 14.)

Initial: "00", mode 0

PD1-0: Power-down control (0: Power-up, 1: Power-down)

PD1: Power down control of DAC1

PD2: Power down control of DAC2

PD3: Power down control of DAC3

PD4: Power down control of DAC4

Addr	Register Name	D7	D6	D5	D4	D3	D2	D1	D0
0AH	Zero detect	OVFE	DZFM3	DZFM2	DZFM1	DZFM0	PWVRN	PWADN	PWDAN
Default		0	0	1	1	1	1	1	1

PWDAN: Power-down control of DAC1-4

0: Power-down

1: Normal operation

PWADN: Power-down control of ADC

0: Power-down

1: Normal operation

PWVRN: Power-down control of reference voltage

0: Power-down

1: Normal operation

DZFM3-0: Zero detect mode select (see Table 11.)

Initial: "0111", disable

OVFE: Overflow detection enable

0: Disable, pin#33 becomes DZF2 pin.

1: Enable, pin#33 becomes OVF pin.

SYSTEM DESIGN

Figure 25 shows the system connection diagram. An evaluation board is available which demonstrates application circuits, the optimum layout, power supply arrangements and measurement results.

Condition: TVDD=5V, 3-wire serial control mode, CAD1-0 = "00"

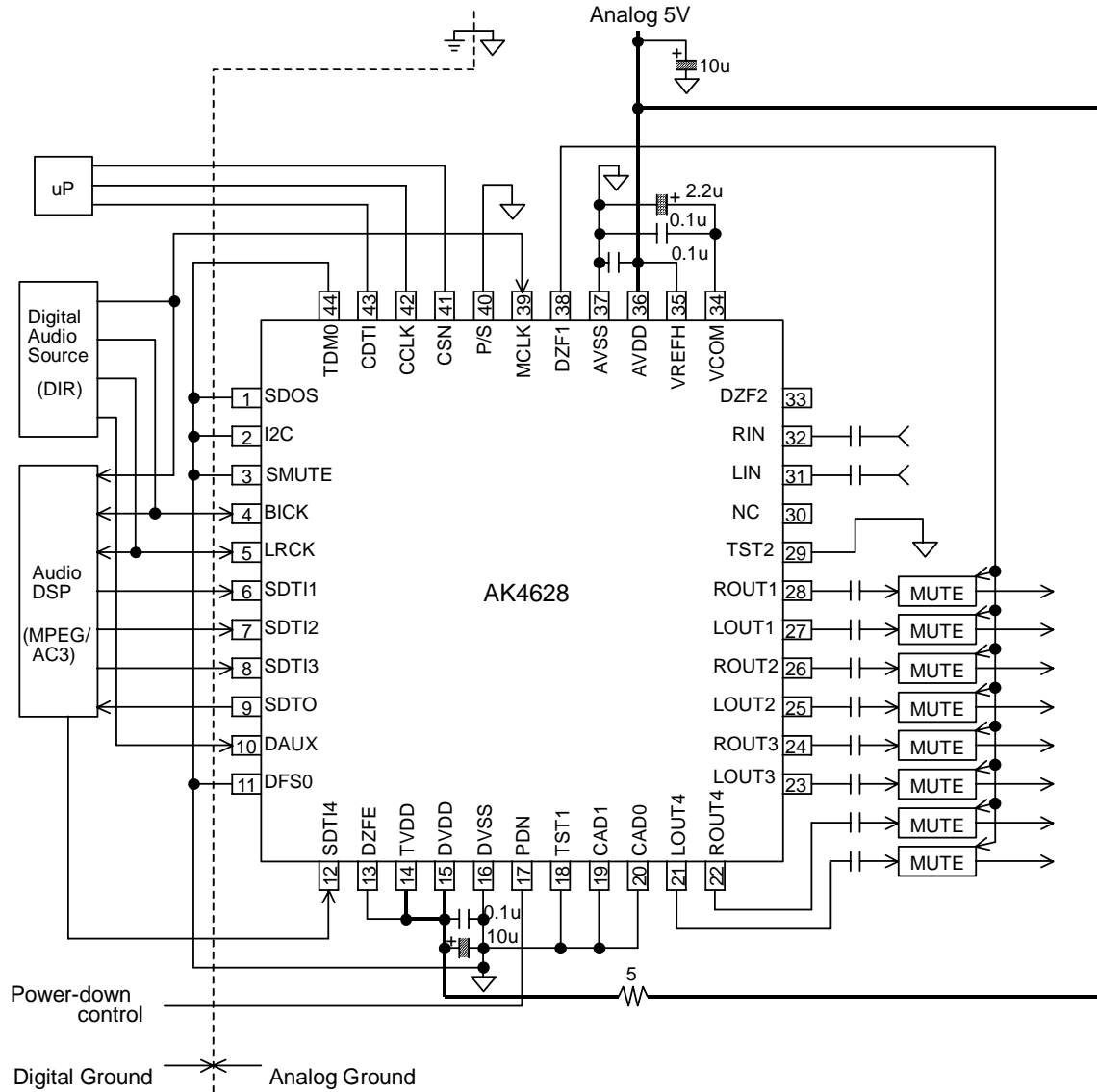

Figure 25. Typical Connection Diagram

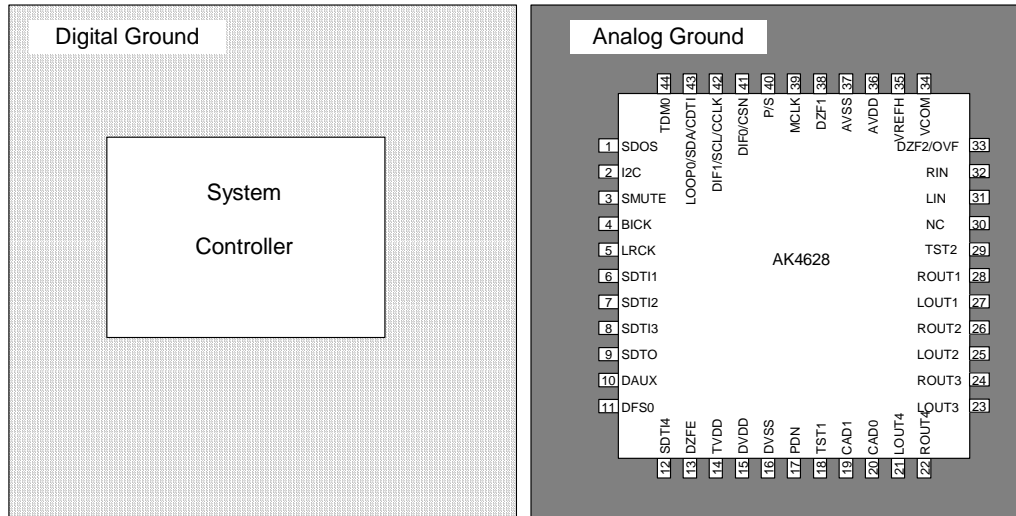

Figure 26. Ground Layout

Note: AVSS and DVSS must be connected to the same analog ground plane.

1. Grounding and Power Supply Decoupling

The AK4628 requires careful attention to power supply and grounding arrangements. AVDD and DVDD are usually supplied from analog supply in system. Alternatively if AVDD and DVDD are supplied separately, the power up sequence is not critical. **AVSS and DVSS of the AK4628 must be connected to analog ground plane.** System analog ground and digital ground should be connected together near to where the supplies are brought onto the printed circuit board. Decoupling capacitors should be as near to the AK4628 as possible, with the small value ceramic capacitor being the nearest.

2. Voltage Reference Inputs

The voltage of VREFH sets the analog input/output range. VREFH pin is normally connected to AVDD with a 0.1 μ F ceramic capacitor. VCOM is a signal ground of this chip. An electrolytic capacitor 2.2 μ F parallel with a 0.1 μ F ceramic capacitor attached to VCOM pin eliminates the effects of high frequency noise. No load current may be drawn from VCOM pin. All signals, especially clocks, should be kept away from the VREFH and VCOM pins in order to avoid unwanted coupling into the AK4628.

3. Analog Inputs

ADC inputs are single-ended and internally biased to VCOM. The input signal range scales with the supply voltage and nominally 0.62 x VREFH V_{pp} (typ)@fs=48kHz. The ADC output data format 2's compliment. The DC offset is removed by the internal HPF.

The AK4628 samples the analog inputs at 64fs. The digital filter rejects noise above the stop band except for multiples of 64fs. The AK4628 includes an anti-aliasing filter (RC filter) to attenuate a noise around 64fs.

4. Analog Outputs

The analog outputs are also single-ended and centered around the VCOM voltage. The input signal range scales with the supply voltage and nominally $0.6 \times VREFH$ Vpp. The DAC input data format is 2's complement. The output voltage is a positive full scale for 7FFFFFFH(@24bit) and a negative full scale for 800000H(@24bit). The ideal output is VCOM voltage for 000000H(@24bit). The internal analog filters remove most of the noise generated by the delta-sigma modulator of DAC beyond the audio passband.

DC offsets on analog outputs are eliminated by AC coupling since DAC outputs have DC offsets of a few mV.

■ Peripheral I/F Example

The AK4628 can accept the signal of device with a nominal 3.3V supply because of TTL input. The power supply for output buffer (TVDD) of the AK4628 should be 3.3V when the peripheral devices operate at a nominal 3.3V supply. Figure 27 shows an example with the mixed system of 3.3V and 5V.

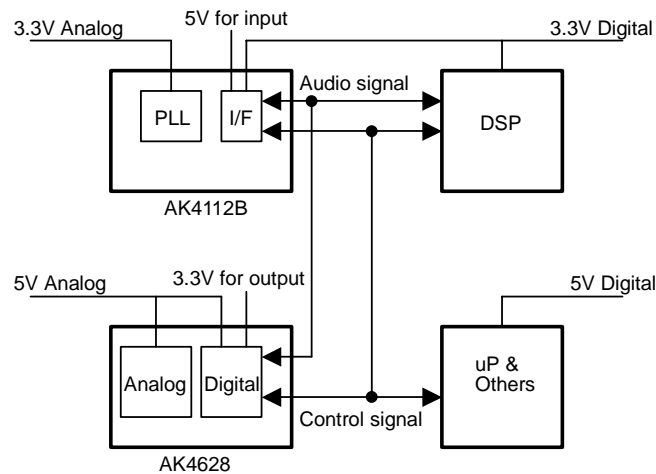
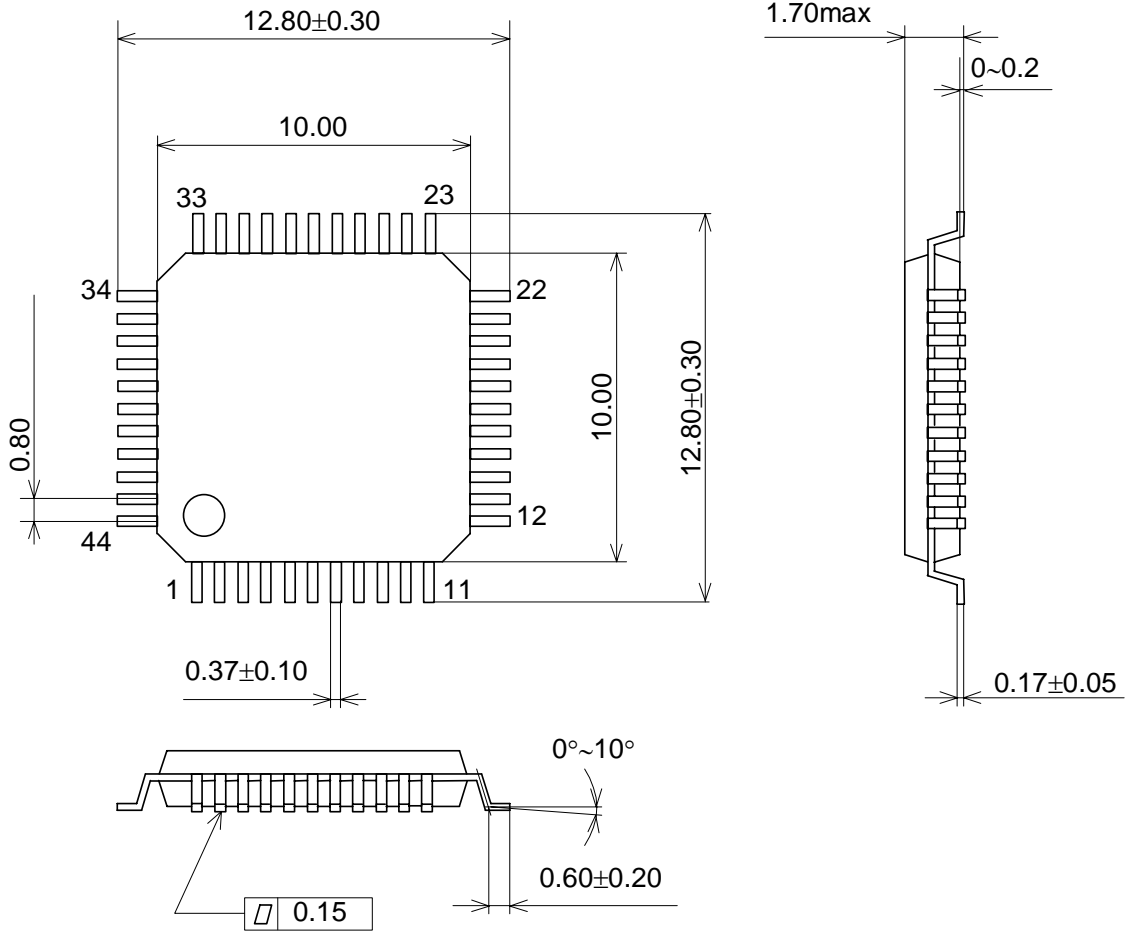

Figure 27. Power supply connection example

PACKAGE

44pin LQFP (Unit: mm)



■ Package & Lead frame material

Package molding compound:	Epoxy
Lead frame material:	Cu
Lead frame surface treatment:	Solder (Pb free) plate

MARKING

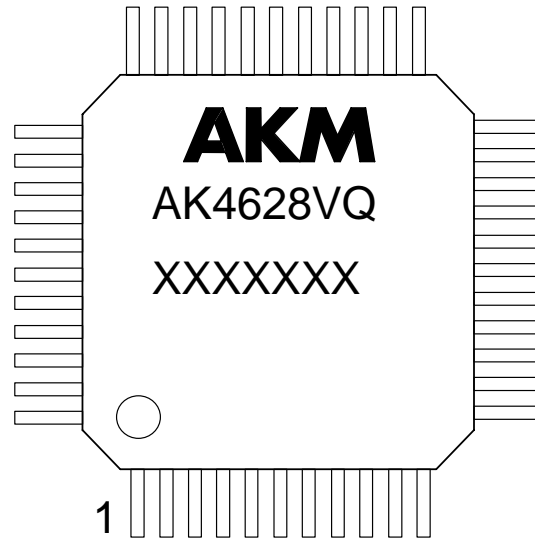

- 1) Pin #1 indication
- 2) Date Code: XXXXXXX(7 digits)
- 3) Marking Code: AK4628VQ
- 4) Asahi Kasei Logo

IMPORTANT NOTICE

- These products and their specifications are subject to change without notice. Before considering any use or application, consult the Asahi Kasei Microsystems Co., Ltd. (AKM) sales office or authorized distributor concerning their current status.
- AKM assumes no liability for infringement of any patent, intellectual property, or other right in the application or use of any information contained herein.
- Any export of these products, or devices or systems containing them, may require an export license or other official approval under the law and regulations of the country of export pertaining to customs and tariffs, currency exchange, or strategic materials.
- AKM products are neither intended nor authorized for use as critical components in any safety, life support, or other hazard related device or system, and AKM assumes no responsibility relating to any such use, except with the express written consent of the Representative Director of AKM. As used here:
 - (a) A hazard related device or system is one designed or intended for life support or maintenance of safety or for applications in medicine, aerospace, nuclear energy, or other fields, in which its failure to function or perform may reasonably be expected to result in loss of life or in significant injury or damage to person or property.
 - (b) A critical component is one whose failure to function or perform may reasonably be expected to result, whether directly or indirectly, in the loss of the safety or effectiveness of the device or system containing it, and which must therefore meet very high standards of performance and reliability.
- It is the responsibility of the buyer or distributor of an AKM product who distributes, disposes of, or otherwise places the product with a third party to notify that party in advance of the above content and conditions, and the buyer or distributor agrees to assume any and all responsibility and liability for and hold AKM harmless from any and all claims arising from the use of said product in the absence of such notification.