

	<h1 style="margin: 0;">AK4527B</h1> <h2 style="margin: 0;">High Performance Multi-channel Audio CODEC</h2>
---	--

GENERAL DESCRIPTION

The AK4527B is a single chip CODEC that includes two channels of ADC and six channels of DAC. The ADC outputs 24bit data and the DAC accepts up to 24bit input data. The ADC has the Enhanced Dual Bit architecture with wide dynamic range. The DAC introduces the new developed Advanced Multi-Bit architecture, and achieves wider dynamic range and lower outband noise. An auxiliary digital audio input interface maybe used instead of the ADC for passing audio data to the primary audio output port. Control may be set directly by pins or programmed through a separate serial interface.

The AK4527B has a dynamic range of 102dB for ADC, 106dB for DAC and is well suited for digital surround for home theater and car audio. An AC-3 system can be built with a IEC60958(SPDIF) receiver such as the AK4112A. The AK4527B is available in a small 44pin LQFP package which will reduce system space.

*AC-3 is a trademark of Dolby Laboratories.

FEATURES

- 2ch 24bit ADC**
 - 64x Oversampling
 - Sampling Rate up to 96kHz
 - Linear Phase Digital Anti-Alias Filter
 - Differential Inputs with single-ended use capability
 - S/(N+D): 92dB
 - Dynamic Range, S/N: 102dB
 - Digital HPF for offset cancellation
 - I/F format: MSB justified or I²S
 - Overflow flag
- 6ch 24bit DAC**
 - 128x Oversampling
 - Sampling Rate up to 96kHz
 - 24bit 8 times Digital Filter
 - Single-Ended Outputs
 - On-chip Switched-Capacitor Filter
 - S/(N+D): 90dB
 - Dynamic Range, S/N: 106dB
 - I/F format: MSB justified, LSB justified(20bit,24bit) or I²S
 - Individual channel digital volume with 256 levels and 0.5dB step
 - Soft mute
 - De-emphasis for 32kHz, 44.1kHz and 48kHz
 - Zero Detect Function
- High Jitter Tolerance**
- TTL Level Digital I/F**
- 3-wire Serial and I²C Bus μ P I/F for mode setting**
- Master clock: 256fs, 384fs or 512fs for fs=32kHz to 48kHz
128fs, 192fs or 256fs for fs=64kHz to 96kHz**
- Power Supply: 4.5 to 5.5V**
- Power Supply for output buffer: 2.7 to 5.5V**
- Small 44pin LQFP**

■ Block Diagram

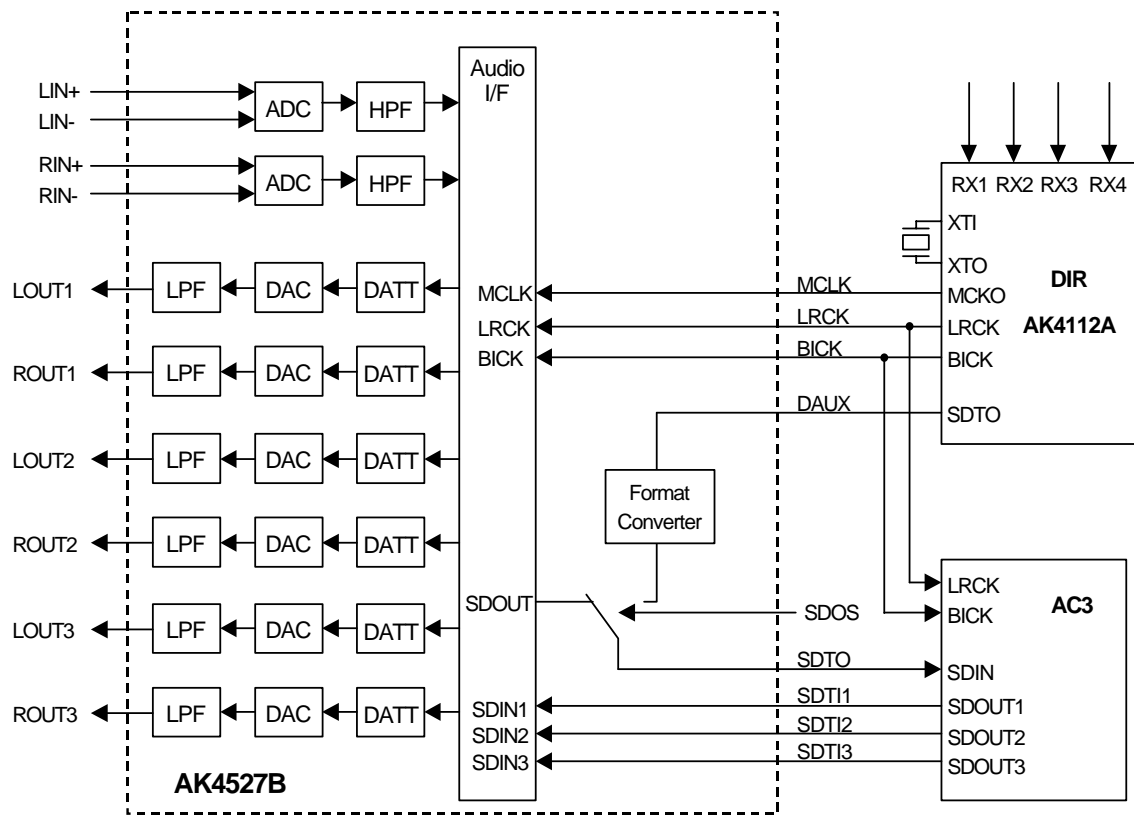

Block Diagram (DIR and AC-3 DSP are external parts)

■ Ordering Guide

AK4527BVQ
AKD4527B

-40 ~ +85°C
Evaluation Board for AK4527B

44pin LQFP(0.8mm pitch)

■ Pin Layout

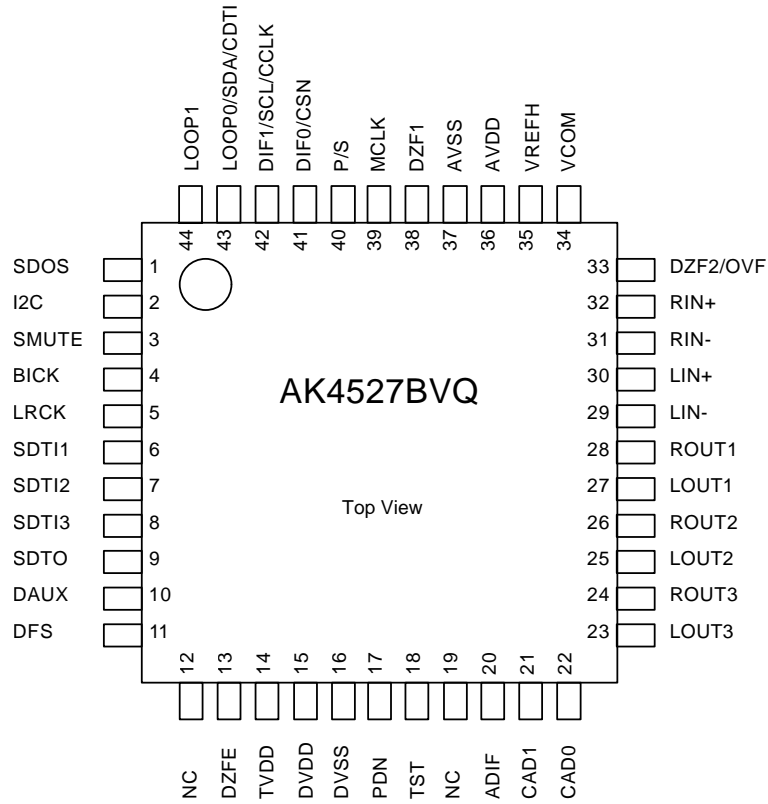

■ Compatibility with AK4527

1. Functions

Functions	AK4527	AK4527B
Overflow flag	Not available	Available
Clock mode	Setting by pin/bit	Auto setting
Sampling speed mode auto setting	Not available	Available (MCLK is fixed at auto setting mode; Normal: 512fs, Double: 256fs)
Zero detection	Serial mode only	Parallel/Serial mode
De-emphasis setting	Pin/Register	Register only
I ² C bus mode	Not available	Available
Analog output at power down mode	Hi-Z	VCOM voltage

2. Pin Configuration

Pin#	AK4527	AK4527B
12	DEM1	NC
13	DEM0	DZFE
18	ICKS2	TST
19	ICKS1	NC
20	ICKS0	ADIF
33	DZF2	DZF2/OVF

3. Register

Addr	Changed items
00H	DIF1-0 default values are changed from mode 0 to mode 2.
01H	ACKS (Clock auto setting mode) is added.
08H	DEMA1-C0 default values are changed from “44.1kHz” to “OFF”.
09H	ICKS2-0 are removed.
0AH	OVFE (Overflow detection enable) is added.

PIN/FUNCTION			
No.	Pin Name	I/O	Function
1	SDOS	I	SDTO Source Select Pin (Note 1) “L”: Internal ADC output, “H”: DAUX input
2	I2C	I	Control Mode Select Pin “L”: 3-wire Serial, “H”: I ² C Bus
3	SMUTE	I	Soft Mute Pin (Note 1) When this pin goes to “H”, soft mute cycle is initialized. When returning to “L”, the output mute releases.
4	BICK	I	Audio Serial Data Clock Pin
5	LRCK	I	Input Channel Clock Pin
6	SDTI1	I	DAC1 Audio Serial Data Input Pin
7	SDTI2	I	DAC2 Audio Serial Data Input Pin
8	SDTI3	I	DAC3 Audio Serial Data Input Pin
9	SDTO	O	Audio Serial Data Output Pin
10	DAUX	I	AUX Audio Serial Data Input Pin
11	DFS	I	Double Speed Sampling Mode Pin (Note 1) “L”: Normal Speed, “H”: Double Speed
12	NC	-	No Connect No internal bonding.
13	DZFE	I	Zero Input Detect Enable Pin “L”: mode 7 (disable) at parallel mode, zero detect mode is selectable by DZFM2-0 bits at serial mode “H”: mode 0 (DZF1 is AND of all six channels)
14	TVDD	-	Output Buffer Power Supply Pin, 2.7V~5.5V
15	DVDD	-	Digital Power Supply Pin, 4.5V~5.5V
16	DVSS	-	Digital Ground Pin, 0V
17	PDN	I	Power-Down & Reset Pin When “L”, the AK4527B is powered-down and the control registers are reset to default state. If the state of P/S or CAD0-1 changes, then the AK4527B must be reset by PDN.
18	TST	I	Test Pin This pin should be connected to DVSS.
19	NC	-	No Connect No internal bonding.
20	ADIF	I	Analog Input Format Select Pin “H”: Full-differential input, “L”: Single-ended input
21	CAD1	I	Chip Address 1 Pin
22	CAD0	I	Chip Address 0 Pin

No.	Pin Name	I/O	Function
23	LOUT3	O	DAC3 Lch Analog Output Pin
24	ROUT3	O	DAC3 Rch Analog Output Pin
25	LOUT2	O	DAC2 Lch Analog Output Pin
26	ROUT2	O	DAC2 Rch Analog Output Pin
27	LOUT1	O	DAC1 Lch Analog Output Pin
28	ROUT1	O	DAC1 Rch Analog Output Pin
29	LIN-	I	Lch Analog Negative Input Pin
30	LIN+	I	Lch Analog Positive Input Pin
31	RIN-	I	Rch Analog Negative Input Pin
32	RIN+	I	Rch Analog Positive Input Pin
33	DZF2	O	Zero Input Detect 2 Pin (Note 2) When the input data of the group 1 follow total 8192 LRCK cycles with "0" input data, this pin goes to "H".
	OVF	O	Analog Input Overflow Detect Pin (Note 3) This pin goes to "H" if the analog input of Lch or Rch is overflows.
34	VCOM	O	Common Voltage Output Pin, AVDD/2 Large external capacitor around 2.2 μ F is used to reduce power-supply noise.
35	VREFH	I	Positive Voltage Reference Input Pin, AVDD
36	AVDD	-	Analog Power Supply Pin, 4.5V~5.5V
37	AVSS	-	Analog Ground Pin, 0V
38	DZF1	O	Zero Input Detect 1 Pin (Note 2) When the input data of the group 1 follow total 8192 LRCK cycles with "0" input data, this pin goes to "H".
39	MCLK	I	Master Clock Input Pin
40	P/S	I	Parallel/Serial Select Pin "L": Serial control mode, "H": Parallel control mode
41	DIF0	I	Audio Data Interface Format 0 Pin in parallel control mode
	CSN	I	Chip Select Pin in 3-wire serial control mode This pin should be connected to DVDD at I ² C bus control mode
42	DIF1	I	Audio Data Interface Format 1 Pin in parallel control mode
	SCL/CCLK	I	Control Data Clock Pin in serial control mode I2C = "L": CCLK (3-wire Serial), I2C = "H": SCL (I ² C Bus)
43	LOOP0	I	Loopback Mode 0 Pin in parallel control mode Enables digital loop-back from ADC to 3 DACs.
	SDA/CDTI	I/O	Control Data Input Pin in serial control mode I2C = "L": CDTI (3-wire Serial), I2C = "H": SDA (I ² C Bus)
44	LOOP1	I	Loopback Mode 1 Pin (Note 1) Enables all 3 DAC channels to be input from SDTI1.

- Notes: 1. SDOS, SMUTE, DFS, and LOOP1 pins are ORed with register data if P/S = "L".
2. The group 1 and 2 can be selected by DZFM2-0 bits if P/S = "L" and DZFE = "L".
3. This pin becomes OVF pin if OVFE bit is set to "1" at serial control mode.
4. All input pins should not be left floating.

ABSOLUTE MAXIMUM RATINGS

(AVSS, DVSS=0V; Note 5)

Parameter		Symbol	min	max	Units
Power Supplies	Analog	AVDD	-0.3	6.0	V
	Digital	DVDD	-0.3	6.0	V
	Output buffer	TVDD	-0.3	6.0	V
	AVSS-DVSS (Note 6)	ΔGND	-	0.3	V
Input Current (any pins except for supplies)		IIN	-	±10	mA
Analog Input Voltage		VINA	-0.3	AVDD+0.3	V
Digital Input Voltage		VIND	-0.3	DVDD+0.3	V
Ambient Temperature (power applied)		Ta	-40	85	°C
Storage Temperature		Tstg	-65	150	°C

Notes: 5. All voltages with respect to ground.
 6. AVSS and DVSS must be connected to the same analog ground plane.

WARNING: Operation at or beyond these limits may result in permanent damage to the device.
 Normal operation is not guaranteed at these extremes.

RECOMMENDED OPERATING CONDITIONS

(AVSS, DVSS=0V; Note 5)

Parameter		Symbol	min	typ	max	Units
Power Supplies (Note 7)	Analog	AVDD	4.5	5.0	5.5	V
	Digital	DVDD	4.5	5.0	5.5	V
	Output buffer	TVDD	2.7	5.0	5.5	V

Notes: 5. All voltages with respect to ground.
 7. The power up sequence between AVDD, DVDD and TVDD is not critical.

WARNING: AKM assumes no responsibility for the usage beyond the conditions in this datasheet.

ANALOG CHARACTERISTICS

(Ta=25°C; AVDD, DVDD, TVDD=5V; AVSS, DVSS=0V; VREFH=AVDD; fs=44.1kHz; BICK=64fs;
Signal Frequency=1kHz; 24bit Data; Measurement Frequency=20Hz~20kHz at fs=44.1kHz, 20Hz~40kHz at fs=96kHz;
unless otherwise specified)

Parameter	min	typ	max	Units
ADC Analog Input Characteristics: Differential Inputs; Analog Source Impedance=470Ω				
Resolution			24	Bits
S/(N+D) (-0.5dBFS) (Note 8)	fs=44.1kHz	84	92	dB
	fs=96kHz	-	83	dB
DR (-60dBFS)	fs=44.1kHz, A-weighted	94	102	dB
	fs=96kHz	88	96	dB
	fs=96kHz, A-weighted	93	102	dB
S/N (Note 9)	fs=44.1kHz, A-weighted	94	102	dB
	fs=96kHz	88	96	dB
	fs=96kHz, A-weighted	93	102	dB
Interchannel Isolation	90	110		dB
DC Accuracy				
Interchannel Gain Mismatch		0.2	0.3	dB
Gain Drift		20	-	ppm/°C
Input Voltage AIN=0.6xVREFH (Note 10)	2.85	3.0	3.15	Vpp
Input Resistance (Note 11)	18	28		kΩ
Power Supply Rejection (Note 12)		50		dB
DAC Analog Output Characteristics:				
Resolution			24	Bits
S/(N+D)	fs=44.1kHz	80	90	dB
	fs=96kHz	78	88	dB
DR (-60dBFS)	fs=44.1kHz, A-weighted	95	106	dB
	fs=96kHz	88	100	dB
	fs=96kHz, A-weighted	94	106	dB
S/N (Note 13)	fs=44.1kHz, A-weighted	95	106	dB
	fs=96kHz	88	100	dB
	fs=96kHz, A-weighted	94	106	dB
Interchannel Isolation	90	110		dB
DC Accuracy				
Interchannel Gain Mismatch		0.2	0.5	dB
Gain Drift		20	-	ppm/°C
Output Voltage AOUT=0.6xVREFH	2.75	3.0	3.25	Vpp
Load Resistance	5			kΩ
Power Supply Rejection (Note 12)		50		dB
Power Supplies				
Power Supply Current				
Normal Operation (PDN = "H")				
AVDD		35	56	mA
DVDD+TVDD fs=44.1kHz (Note 14)		25	40	mA
	fs=96kHz	35	56	mA
Power-down mode (PDN = "L") (Note 15)		80	200	μA

Notes: 8. In case of single ended input, S/(N+D)=80dB(typ, @AVDD=5V, fs=44.1kHz).

9. S/N measured by CCIR-ARM is 98dB(@fs=44.1kHz).

10. Full scale input for each AIN+/- pin is 1.5Vpp in differential mode.

11. Input resistance is 14kΩ typically at fs=96kHz.

12. PSR is applied to AVDD, DVDD and TVDD with 1kHz, 50mVpp. VREFH pin is held a constant voltage.

13. S/N measured by CCIR-ARM is 102dB(@fs=44.1kHz).

14. DVDD=TBDmA, TVDD=TBDmA(typ).

15. In the power-down mode. All digital input pins including clock pins (MCLK, BICK, LRCK) are held DVSS.

FILTER CHARACTERISTICS							
(Ta=25°C; AVDD, DVDD=4.5~5.5V; TVDD=2.7~5.5V; fs=44.1kHz; DEM=OFF)							
Parameter	Symbol	min	typ	max	Units		
ADC Digital Filter (Decimation LPF):							
Passband (Note 16)	-0.005dB -0.02dB -0.06dB -6.0dB	PB	0		19.76	kHz	
			-	20.02	-	kHz	
			-	20.20	-	kHz	
			-	22.05	-	kHz	
Stopband		SB	24.34			kHz	
Passband Ripple		PR			±0.005	dB	
Stopband Attenuation		SA	80			dB	
Group Delay (Note 17)		GD		27.6		1/fs	
Group Delay Distortion		ΔGD		0		μs	
ADC Digital Filter (HPF):							
Frequency Response (Note 16)	-3dB -0.5dB -0.1dB	FR		0.9		Hz	
				2.7		Hz	
				6.0		Hz	
DAC Digital Filter:							
Passband (Note 16)	-0.1dB -6.0dB	PB	0		20.0	kHz	
			-	22.05	-	kHz	
Stopband		SB	24.2			kHz	
Passband Ripple		PR			±0.02	dB	
Stopband Attenuation		SA	56			dB	
Group Delay (Note 17)		GD		21.9		1/fs	
DAC Digital Filter + Analog Filter:							
Frequency Response:	0 ~ 20.0kHz	FR		±0.2		dB	
	40.0kHz (Note 18)	FR		±0.3		dB	

Notes: 16. The passband and stopband frequencies scale with fs.

For example, 20.02kHz at -0.02dB is 0.454 x fs. The reference frequency of these responses is 1kHz.

17. The calculating delay time which occurred by digital filtering. This time is from setting the input of analog signal to setting the 24bit data of both channels to the output register for ADC.

For DAC, this time is from setting the 20/24bit data of both channels on input register to the output of analog signal.

18. fs=96kHz.

DC CHARACTERISTICS

(Ta=25°C; AVDD, DVDD=4.5~5.5V; TVDD=2.7~5.5V)

Parameter	Symbol	min	typ	max	Units
High-Level Input Voltage	VIH	2.2	-	-	V
Low-Level Input Voltage	VIL	-	-	0.8	V
High-Level Output Voltage					
(SDIO pin: Iout=-100μA)	VOH	TVDD-0.5	-	-	V
(DZF1, DZF2/OZF pins: Iout=-100μA)	VOH	AVDD-0.5	-	-	V
Low-Level Output Voltage					
(SDIO, DZF1, DZF2/OZF pins: Iout= 100μA)	VOL	-	-	0.5	V
(SDA pin: Iout= 3mA)	VOL	-	-	0.4	V
Input Leakage Current	Iin	-	-	±10	μA

SWITCHING CHARACTERISTICS

(Ta=25°C; AVDD, DVDD=4.5~5.5V; TVDD=2.7~5.5V; C_L=20pF)

Parameter	Symbol	min	typ	max	Units
Master Clock Input					
256fsn, 128fsd:	fCLK	8.192		12.288	MHz
Pulse Width Low	tCLKL	27			ns
Pulse Width High	tCLKH	27			ns
384fsn, 192fsd:	fCLK	12.288		18.432	MHz
Pulse Width Low	tCLKL	20			ns
Pulse Width High	tCLKH	20			ns
512fsn, 256fsd:	fCLK	16.384		24.576	MHz
Pulse Width Low	tCLKL	15			ns
Pulse Width High	tCLKH	15			ns
LRCK frequency					
Normal Speed Mode	fsn	32		48	kHz
Double Speed Mode	fsd	64		96	kHz
Duty Cycle	Duty	45		55	%
Audio Interface Timing					
BICK Period	tBCK	160			ns
BICK Pulse Width Low	tBCKL	65			ns
Pulse Width High	tBCKH	65			ns
LRCK Edge to BICK “↑” (Note 19)	tLRB	45			ns
BICK “↑” to LRCK Edge (Note 19)	tBLR	45			ns
LRCK to SDTO(MSB)	tLRS			40	ns
BICK “↓” to SDTO	tBSD			40	ns
SDTI1-3, DAUX Hold Time	tSDH	40			ns
SDTI1-3, DAUX Setup Time	tSDS	25			ns

Notes: 19. BICK rising edge must not occur at the same time as LRCK edge.

Parameter	Symbol	min	typ	max	Units
Control Interface Timing (3-wire Serial mode):					
CCLK Period	tCCK	200			ns
CCLK Pulse Width Low	tCCKL	80			ns
Pulse Width High	tCCKH	80			ns
CDTI Setup Time	tCDS	40			ns
CDTI Hold Time	tCDH	40			ns
CSN "H" Time	tCSW	0.025*1/fs			ns
CSN "↓" to CCLK "↑"	tCSS	50			ns
CCLK "↑" to CSN "↑"	tCSH	50			ns
Rise Time of CSN	tR1			20	ns
Fall Time of CSN	tF1			20	ns
Rise Time of CCLK	tR2			20	ns
Fall Time of CCLK	tF2			20	ns
Control Interface Timing (I²C Bus mode):					
SCL Clock Frequency	fSCL	-		100	kHz
Bus Free Time Between Transmissions	tBUF	4.7		-	μs
Start Condition Hold Time (prior to first clock pulse)	tHD:STA	4.0		-	μs
Clock Low Time	tLOW	4.7		-	μs
Clock High Time	tHIGH	4.0		-	μs
Setup Time for Repeated Start Condition	tSU:STA	4.7		-	μs
SDA Hold Time from SCL Falling (Note 20)	tHD:DAT	0		-	μs
SDA Setup Time from SCL Rising	tSU:DAT	0.25		-	μs
Rise Time of Both SDA and SCL Lines	tR	-		1.0	μs
Fall Time of Both SDA and SCL Lines	tF	-		0.3	μs
Setup Time for Stop Condition	tSU:STO	4.0		-	μs
Pulse Width of Spike Noise Suppressed by Input Filter	tSP	0		50	ns
Power-down & Reset Timing					
PDN Pulse Width (Note 21)	tPD	150			ns
PDN "↑" to SDTO valid (Note 22)	tPDV		522		1/fs

- Notes: 20. Data must be held for sufficient time to bridge the 300 ns transition time of SCL.
21. The AK4527B can be reset by bringing PDN "L" to "H" upon power-up.
22. These cycles are the number of LRCK rising from PDN rising.
23. I²C is a registered trademark of Philips Semiconductors.

Purchase of Asahi Kasei Microsystems Co., Ltd I²C components conveys a license under the Philips I²C patent to use the components in the I²C system, provided the system conform to the I²C specifications defined by Philips.

■ Timing Diagram

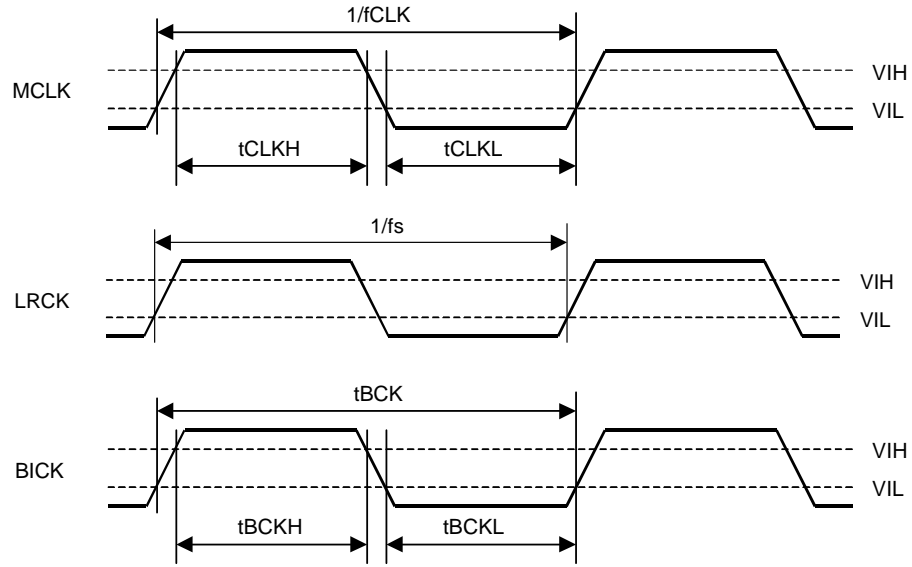

Clock Timing

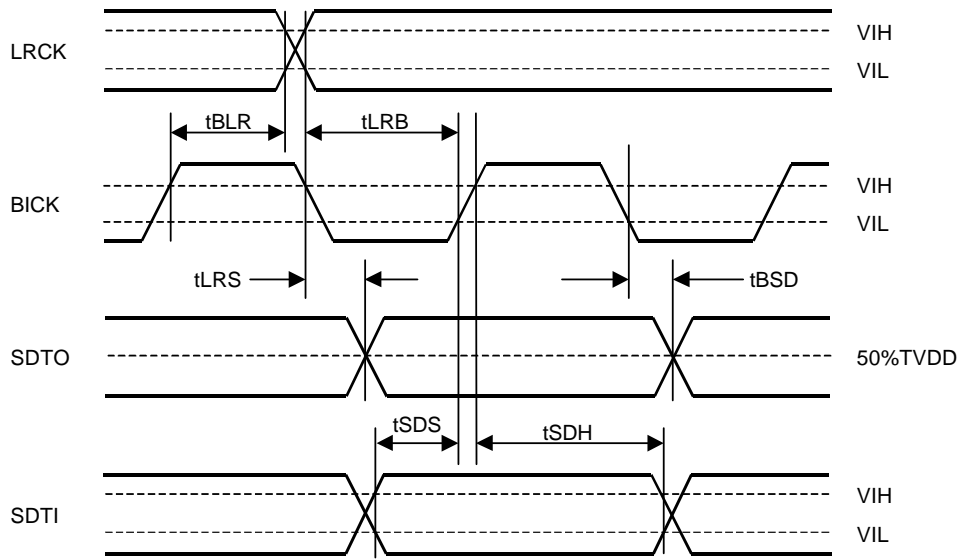

Audio Interface Timing

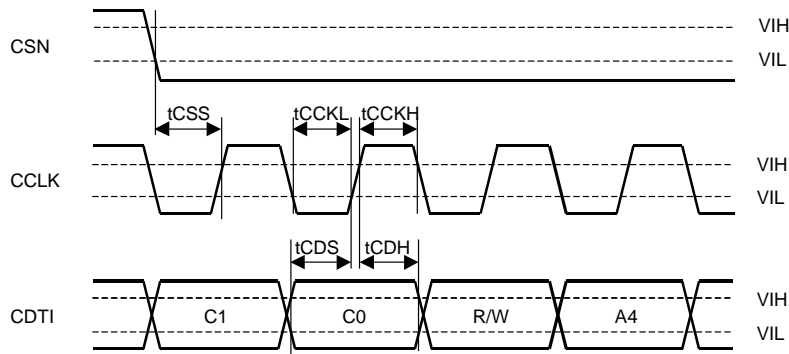

WRITE Command Input Timing (3-wire Serial mode)

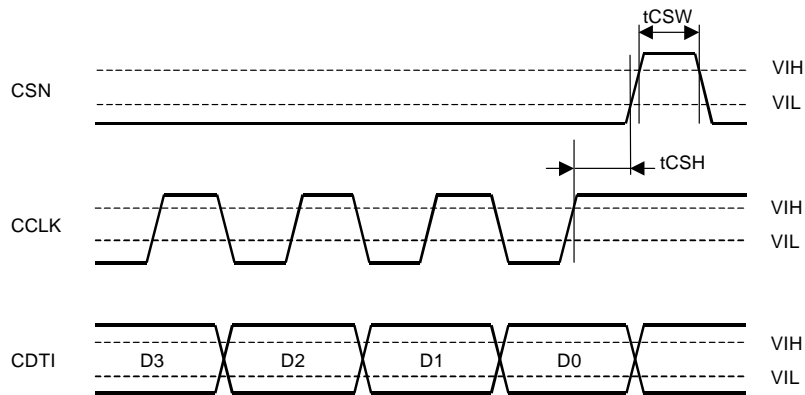

WRITE Data Input Timing (3-wire Serial mode)

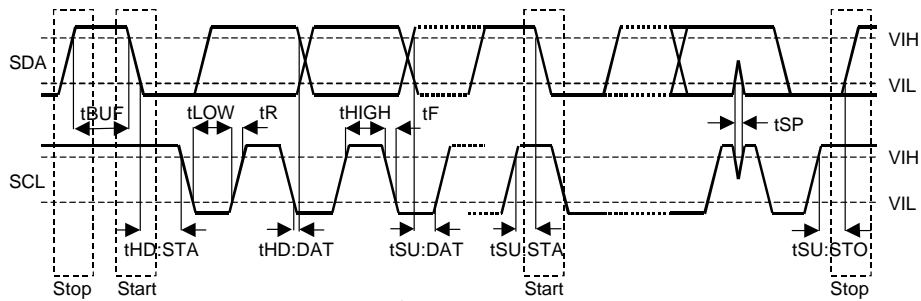

I²C Bus mode Timing

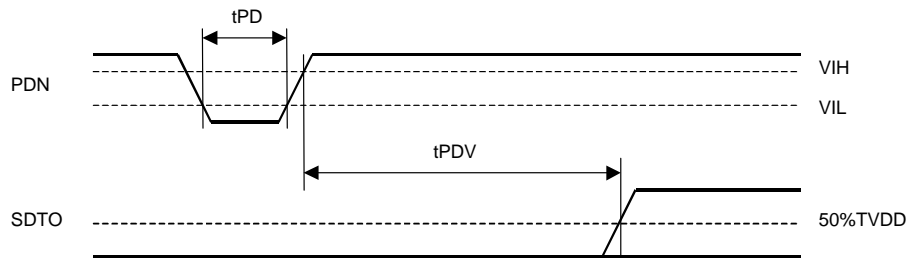

Power-down & Reset Timing

OPERATION OVERVIEW

■ System Clock

The external clocks, which are required to operate the AK4527B, are MCLK, LRCK and BICK. There are two methods to set MCLK frequency. In Manual Setting Mode (ACKS = "0": Default), the sampling speed is set by DFS (Table 1). The frequency of MCLK at each sampling speed is set automatically. (Table 2, 3). In Auto Setting Mode (ACKS = "1"), as MCLK frequency is detected automatically (Table 4), and the internal master clock becomes the appropriate frequency (Table 5), it is not necessary to set DFS.

MCLK should be synchronized with LRCK but the phase is not critical. External clocks (MCLK, BICK) should always be present whenever the AK4527B is in normal operation mode (PDN = "H"). If these clocks are not provided, the AK4527B may draw excess current because the device utilizes dynamic refreshed logic internally. If the external clocks are not present, the AK4527B should be in the power-down mode (PDN = "L") or in the reset mode (RSTN = "0"). After exiting reset at power-up etc., the AK4527B is in the power-down mode until MCLK and LRCK are input.

DFS	Sampling Speed (fs)		Default
0	Normal Speed Mode	32kHz~48kHz	
1	Double Speed Mode	64kHz~96kHz	

Table 1. Sampling Speed (Manual Setting Mode)

LRCK	MCLK (MHz)			BICK (MHz)
	fs	256fs	384fs	
32.0kHz	8.1920	12.2880	16.3840	2.0480
44.1kHz	11.2896	16.9344	22.5792	2.8224
48.0kHz	12.2880	18.4320	24.5760	3.0720

Table 2. System Clock Example (Normal Speed Mode @Manual Setting Mode)

LRCK	MCLK (MHz)			BICK (MHz)
	fs	128fs	192fs	
88.2kHz	11.2896	16.9344	22.5792	5.6448
96.0kHz	12.2880	18.4320	24.5760	6.1440

Table 3. System Clock Example (Double Speed Mode @Manual Setting Mode)
(Note: At double speed mode(DFS = "1"), 128fs and 192fs are not available for ADC.)

MCLK	Sampling Speed
512fs	Normal
256fs	Double

Table 4. Sampling Speed (Auto Setting Mode)

LRCK	MCLK (MHz)		Sampling Speed
	fs	256fs	
32.0kHz	-	16.3840	Normal
44.1kHz	-	22.5792	
48.0kHz	-	24.5760	
88.2kHz	22.5792	-	Double
96.0kHz	24.5760	-	

Table 5. System Clock Example (Auto Setting Mode)

■ De-emphasis Filter

The AK4527B includes the digital de-emphasis filter ($t_c=50/15\mu s$) by IIR filter. This filter corresponds to three sampling frequencies (32kHz, 44.1kHz, 48kHz). De-emphasis of each DAC can be set individually by register data of DEMA1-C0 (DAC1: DEMA1-0, DAC2: DEMB1-0, DAC3: DEMC1-0, see “Register Definitions”).

Mode	Sampling Speed	DEM1	DEM0	DEM	Default
0	Normal Speed	0	0	44.1kHz	
1	Normal Speed	0	1	OFF	
2	Normal Speed	1	0	48kHz	
3	Normal Speed	1	1	32kHz	
4	Double Speed	0	0	OFF	
5	Double Speed	0	1	OFF	
6	Double Speed	1	0	OFF	
7	Double Speed	1	1	OFF	

Table 6. De-emphasis control

■ Digital High Pass Filter

The ADC has a digital high pass filter for DC offset cancel. The cut-off frequency of the HPF is 0.9Hz at $f_s=44.1\text{kHz}$ and also scales with sampling rate (f_s).

■ Audio Serial Interface Format

Four serial data modes can be selected by the DIF0 and DIF1 pins (P/S = “H”) or bits (P/S = “L”) as shown in Table 7. In all modes the serial data is MSB-first, 2’s compliment format. The SDTO is clocked out on the falling edge of BICK and the SDTI/DAUX are latched on the rising edge of BICK.

Figures 1~4 shows the timing at $SDOS = “L”$. In this case, the SDTO outputs the ADC output data. When $SDOS = “H”$, the data input to DAUX is converted to SDTO’s format and output from SDTO. Mode 2 and mode 3 in SDTI/DAUX input formats can be used for 16-20bit data by zeroing the unused LSBs.

Mode	DIF1	DIF0	SDTO	SDTI1-3, DAUX	LRCK	Default
0	0	0	24bit, MSB justified	20bit, LSB justified	H/L	
1	0	1	24bit, MSB justified	24bit, LSB justified	H/L	
2	1	0	24bit, MSB justified	24bit, MSB justified	H/L	
3	1	1	24bit, IIS (I2S)	24bit, IIS (I2S)	L/H	

Table 7. Audio data formats

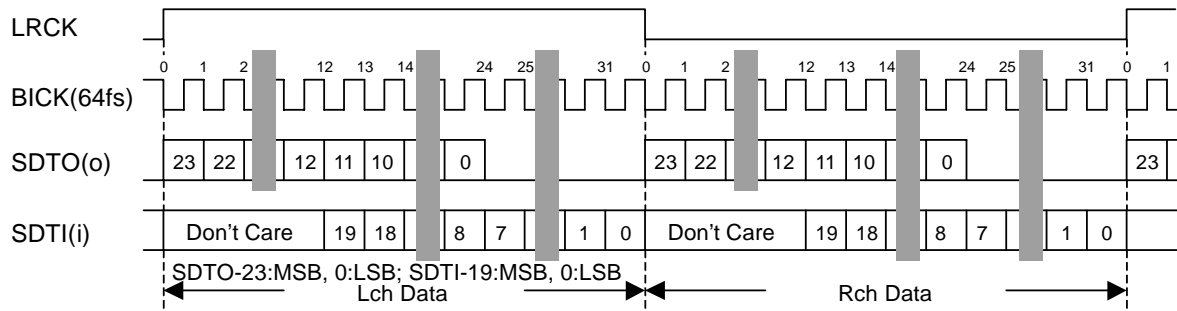

Figure 1. Mode 0 Timing

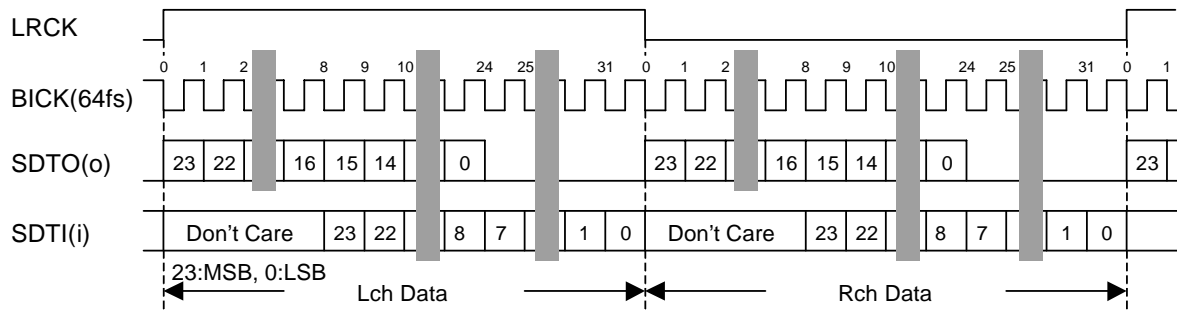

Figure 2. Mode 1 Timing

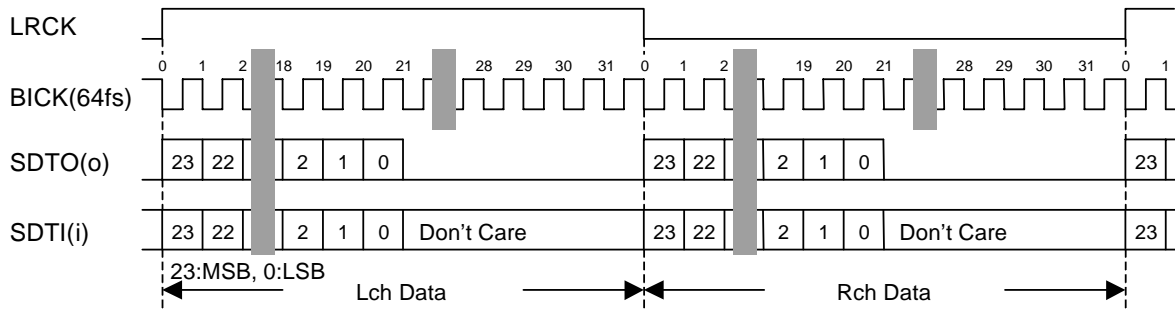

Figure 3. Mode 2 Timing

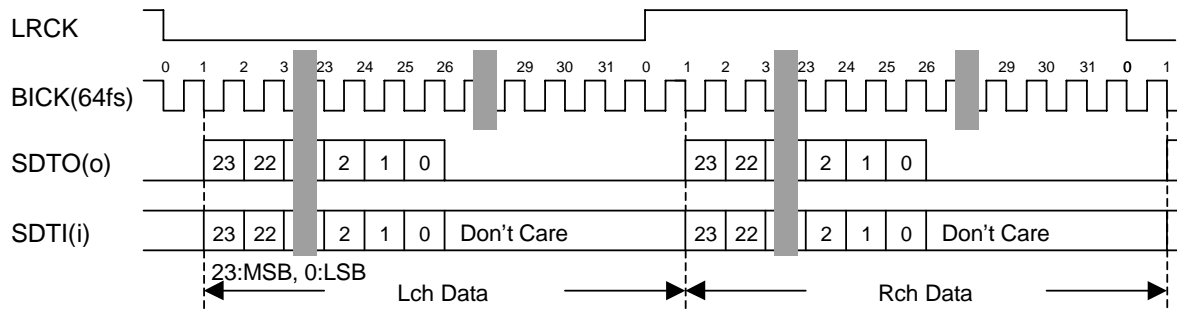

Figure 4. Mode 3 Timing

■ **Overflow Detection**

The AK4527B has overflow detect function for analog input. Overflow detection is enabled when OVFE bit is set to “1” at serial control mode. OVF pin goes to “H” if analog input of Lch or Rch overflows. OVF output for overflowed analog input has the same group delay as ADC ($GD=27.6/fs=626\mu s@fs=44.1kHz$).

OVF is “L” for $522/fs(=11.8ms@fs=44.1kHz)$ after PDN = “↑”, and then overflow detection is enabled.

■ **Zero detection**

The AK4527B has two pins for zero detect flag outputs. Channel grouping can be selected by DZFM2-0 bits if P/S = “L” and DZFE = “L” (table 8). DZF1 pin corresponds to the group 1 channels and DZF2 pin corresponds to the group 2 channels. However DZF2 pin becomes OVF pin if OVFE bit is set to “1”. Zero detection mode is set to mode 0 if DZFE= “H” regardless of P/S pin. DZF1 is AND of all six channels and DZF2 is disabled (“L”) at mode 0. Table 9 shows the relation of P/S, DZFE, OVFE and DZF.

When the input data of all channels in the group 1(group 2) are continuously zeros for 8192 LRCK cycles, DZF1(DZF2) pin goes to “H”. DZF1(DZF2) pin immediately goes to “L” if input data of any channels in the group 1(group 2) is not zero after going DZF1(DZF2) “H”.

Mode	DZFM			AOUT						
	2	1	0	L1	R1	L2	R2	L3	R3	
0	0	0	0	DZF1	DZF1	DZF1	DZF1	DZF1	DZF1	
1	0	0	1	DZF1	DZF1	DZF1	DZF1	DZF1	DZF2	
2	0	1	0	DZF1	DZF1	DZF1	DZF1	DZF2	DZF2	
3	0	1	1	DZF1	DZF1	DZF1	DZF2	DZF2	DZF2	
4	1	0	0	DZF1	DZF1	DZF2	DZF2	DZF2	DZF2	
5	1	0	1	DZF1	DZF2	DZF2	DZF2	DZF2	DZF2	
6	1	1	0	DZF2	DZF2	DZF2	DZF2	DZF2	DZF2	
7	1	1	1	disable (DZF1=DZF2 = “L”)						Default

Table 8. Zero detect control

P/S pin	DZFE pin	OVFE bit	DZF mode	DZF1 pin	DZF2/OVF pin
“H” (parallel mode)	“L”	disable	Mode 7	“L”	“L”
	“H”	disable	Mode 0	AND of 6ch	“L”
“L” (serial mode)	“L”	“0”	Selectable	Selectable	Selectable
		“1”	Selectable	Selectable	OVF output
	“H”	“0”	Mode 0	AND of 6ch	“L”
		“1”	Mode 0	AND of 6ch	OVF output

Table 9. DZF1-2 pins outputs

■ Digital Attenuator

AK4527B has channel-independent digital attenuator (256 levels, 0.5dB step). Attenuation level of each channel can be set by each ATT7-0 bits (table 10).

ATT7-0	Attenuation Level
00H	0dB
01H	-0.5dB
02H	-1.0dB
:	:
FDH	-126.5dB
FEH	-127.0dB
FFH	MUTE ($-\infty$)

Default

Table 10. Attenuation level of digital attenuator

The transition between set values is soft transition of 7425 levels. It takes $7424/f_s$ (168ms@ $f_s=44.1\text{kHz}$) from 00H(0dB) to FFH(MUTE). If PDN pin goes to "L", the ATTs are initialized to 00H. The ATTs are 00H when RSTN = "0". When RSTN return to "1", the ATTs fade to their current value. Digital attenuator is independent of soft mute function.

■ Soft mute operation

Soft mute operation is performed at digital domain. When the SMUTE pin goes to “H”, the output signal is attenuated by $-\infty$ during 1024 LRCK cycles. When the SMUTE pin is returned to “L”, the mute is cancelled and the output attenuation gradually changes to 0dB during 1024 LRCK cycles. If the soft mute is cancelled within 1024 LRCK cycles after starting the operation, the attenuation is discontinued and returned to 0dB. The soft mute is effective for changing the signal source without stopping the signal transmission.

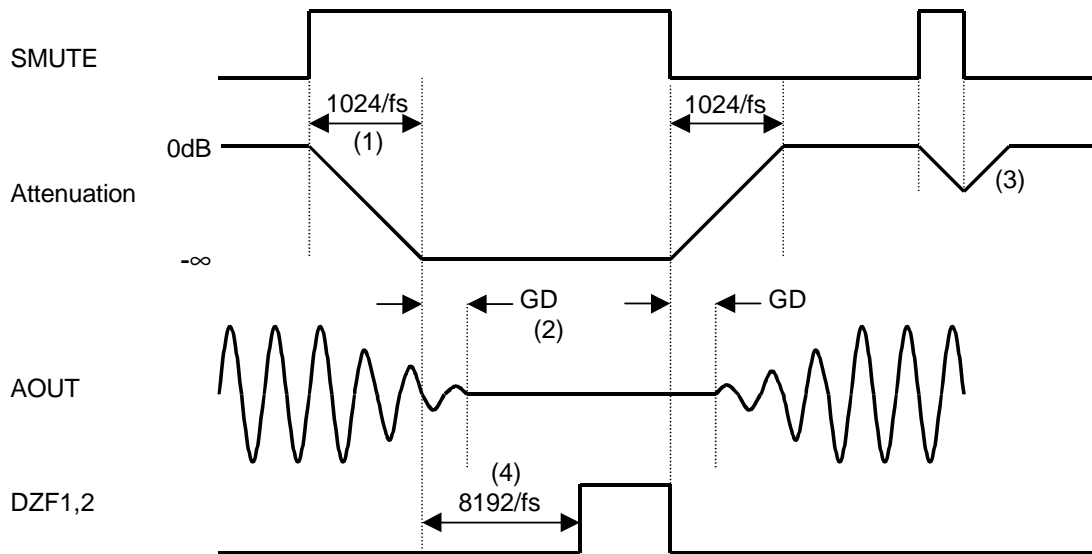

Notes:

- (1) The output signal is attenuated by $-\infty$ during 1024 LRCK cycles ($1024/f_s$).
- (2) Analog output corresponding to digital input have the group delay (GD).
- (3) If the soft mute is cancelled within 1024 LRCK cycles, the attenuation is discontinued and returned to 0dB.
- (4) When the input data of all channels in the group are continuously zeros for 8192 LRCK cycles, DZF pin corresponding to the group goes to “H”. DZF pin immediately goes to “L” if input data of any channel in the group is not zero after going DZF “H”.

Figure 5. Soft mute and zero detection

■ System Reset

The AK4527B should be reset once by bringing PDN = “L” upon power-up. The AK4527B is powered up and the internal timing starts clocking by LRCK “↑” after exiting reset and power down state by MCLK. The AK4527B is in the power-down mode until MCLK and LRCK are input.

■ Power-Down

The ADC and DACs of AK4527B are placed in the power-down mode by bringing PDN “L” and both digital filters are reset at the same time. PDN “L” also reset the control registers to their default values. In the power-down mode, the analog outputs go to VCOM voltage and DZF1-2 pins go to “L”. This reset should always be done after power-up. In case of the ADC, an analog initialization cycle starts after exiting the power-down mode. Therefore, the output data, SDTO becomes available after 522 cycles of LRCK clock. In case of the DAC, an analog initialization cycle starts after exiting the power-down mode. The analog outputs are VCOM voltage during the initialization. Figure 6 shows the power-up sequence.

The ADC and DACs can be powered-down individually by PWADN and PWDAN bits. In this case, the internal register values are not initialized. When PWADN = “0”, SDTO goes to “L”. When PWDAN = “0”, the analog outputs go to VCOM voltage and DZF1-2 pins go to “H”. Because some click noise occurs, the analog output should muted externally if the click noise influences system application.

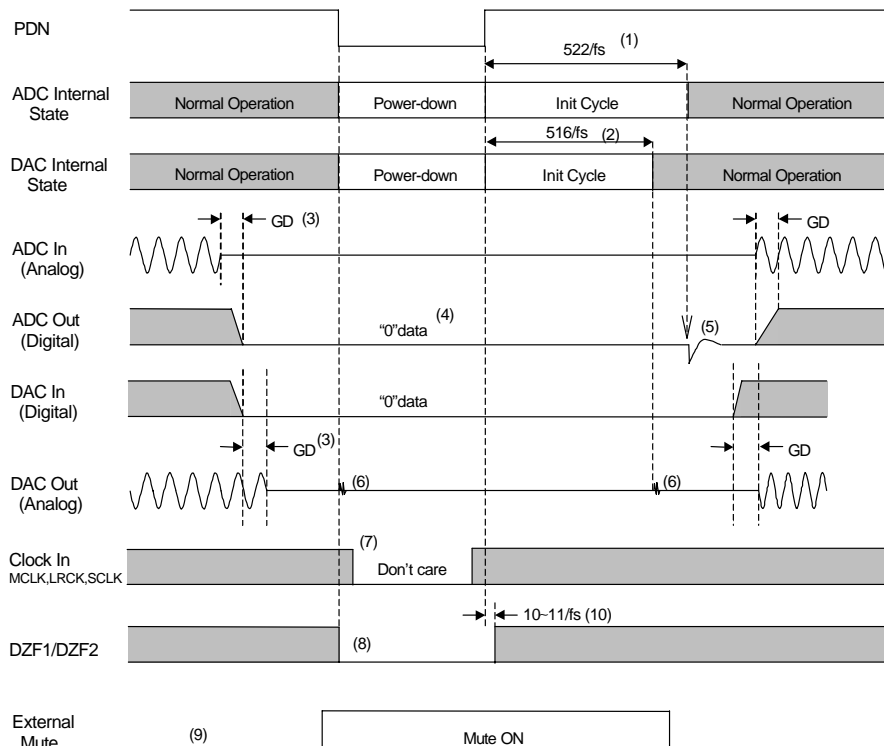

Notes:

- (1) The analog part of ADC is initialized after exiting the power-down state.
- (2) The analog part of DAC is initialized after exiting the power-down state.
- (3) Digital output corresponding to analog input and analog output corresponding to digital input have the group delay (GD).
- (4) ADC output is “0” data at the power-down state.
- (5) Click noise occurs at the end of initialization of the analog part. Please mute the digital output externally if the click noise influences system application. Required muting time depends on the configuration of the input buffer circuits.
Figure 12,13: 1s
Figure 14,15: 200ms
- (6) Click noise occurs at the falling edge of PDN and at 512/fs after the rising edge of PDN.
- (7) When the external clocks (MCLK, BICK and LRCK) are stopped, the AK4527B should be in the power-down mode.
- (8) DZF pins are “L” in the power-down mode (PDN = “L”).
- (9) Please mute the analog output externally if the click noise (6) influences system application.
- (10) DZF= “L” for 10~11/fs after PDN= “↑”.

Figure 6. Power-down/up sequence example

Reset Function

When RSTN = "0", ADC and DACs are powered-down but the internal register are not initialized. The analog outputs go to VCOM voltage, DZF1-2 pins go to "H" and SDTO pin goes to "L". Because some click noise occurs, the analog output should muted externally if the click noise influences system application. Figure 7 shows the power-up sequence.

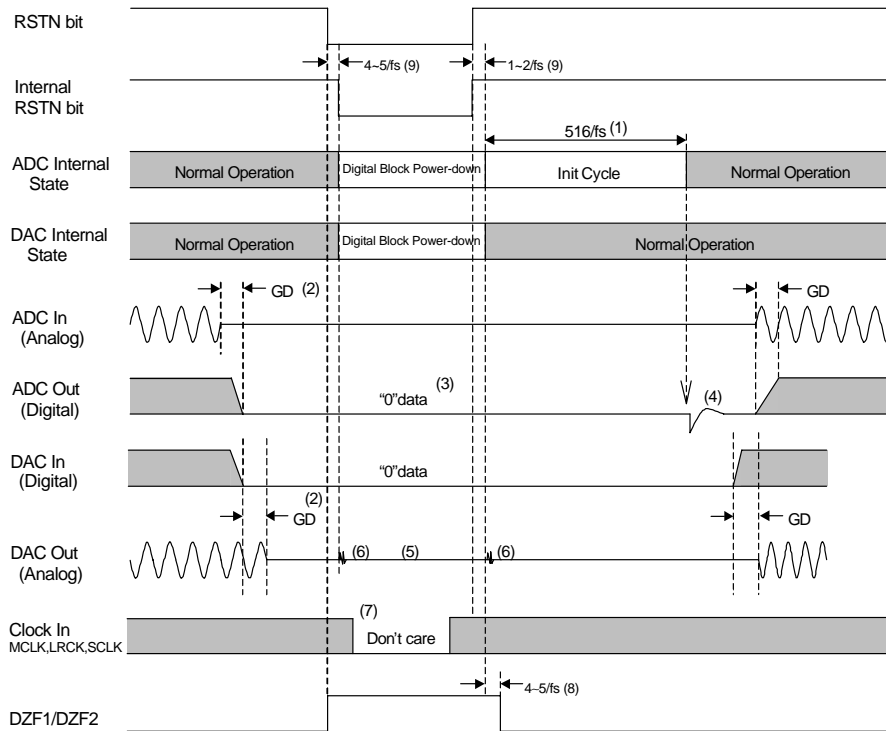

Notes:

- (1) The analog part of ADC is initialized after exiting the reset state.
- (2) Digital output corresponding to analog input and analog output corresponding to digital input have the group delay (GD).
- (3) ADC output is "0" data at the power-down state.
- (4) Click noise occurs when the internal RSTN bit becomes "1". Please mute the digital output externally if the click noise influences system application. Required muting time depends on the configuration of the input buffer circuits.
Figure 12,13: 1s
Figure 14,15: 200ms
- (5) The analog outputs go to VCOM voltage.
- (6) Click noise occurs at 4~5/fs after RSTN bit becomes "0", and occurs at 1~2/fs after RSTN bit becomes "1". This noise is output even if "0" data is input.
- (7) The external clocks (MCLK, BICK and LRCK) can be stopped in the reset mode. When exiting the reset mode, "1" should be written to RSTN bit after the external clocks (MCLK, BICK and LRCK) are fed.
- (8) DZF pins go to "H" when the RSTN bit becomes "0", and go to "L" at 6~7/fs after RSTN bit becomes "1".
- (9) There is a delay, 4~5/fs from RSTN bit "0" to the internal RSTN bit "0".

Figure 7. Reset sequence example

■ Serial Control Interface

The AK4527B can control its functions via registers. Internal registers may be written by 2 types of control mode. The chip address is determined by the state of the CAD0 and CAD1 inputs. PDN = "L" initializes the registers to their default values. Writing "0" to the RSTN bit can initialize the internal timing circuit. But in this case, the register data is not be initialized. When the state of P/S pin is changed, the AK4527B should be reset by PDN pin.

- * Writing to control register is invalid when PDN = "L" or the MCLK is not fed.
- * AK4527B does not support the read command.

(1) 3-wire Serial Control Mode (I2C = "L")

Internal registers may be written to the 3 wire μ P interface pins (CSN,CCLK and CDTI). The data on this interface consists of Chip address (2bits, CAD0/1), Read/Write (1bit, Fixed to "1"; Write only), Register address (MSB first, 5bits) and Control data (MSB first, 8bits). Address and data is clocked in on the rising edge of CCLK and data is clocked out on the falling edge. For write operations, data is latched after a low-to-high transition of CSN. The clock speed of CCLK is 5MHz(max). The CSN pins should be held to "H" except for access.

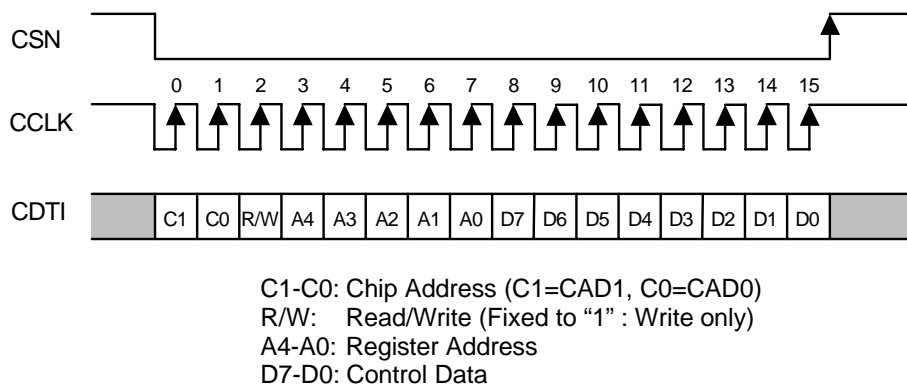

Figure 8. 3-wire Serial Control I/F Timing

(2) I²C Bus Control Mode (I2C = "H")

Internal registers may be written to I²C Bus interface pins: SCL & SDA. The data on this interface consists of Chip address (2bits, CAD0/1), Read/Write (1bit, Fixed to "0"; Write only), Register address (MSB first, 5bits) and Control data (MSB first, 8bits). Address and data is clocked in on the rising edge of SCL and data is clocked out on the falling edge. Data can be written after a high-to-low transition of SDA when SCL is "H"(start condition), and is latched after a low-to-high transition of SDA when SCL is "H"(stop condition). The clock speed of SCL is 100kHz(max). The CSN pin should be connected to DVDD at I²C Bus control mode. The AK4527B does not have a register address auto increment capability.

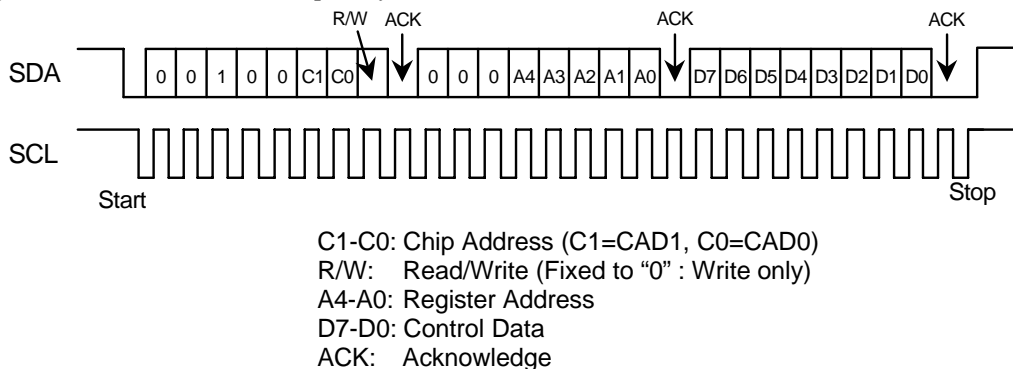

Figure 9. I²C-bus Control I/F Timing

■ Mapping of Program Registers

Addr	Register Name	D7	D6	D5	D4	D3	D2	D1	D0
00H	Control 1	0	0	0	0	DIF1	DIF0	0	SMUTE
01H	Control 2	0	0	LOOP1	LOOP0	SDOS	DFS	ACKS	0
02H	LOUT1 Volume Control	ATT7	ATT6	ATT5	ATT4	ATT3	ATT2	ATT1	ATT0
03H	ROUT1 Volume Control	ATT7	ATT6	ATT5	ATT4	ATT3	ATT2	ATT1	ATT0
04H	LOUT2 Volume Control	ATT7	ATT6	ATT5	ATT4	ATT3	ATT2	ATT1	ATT0
05H	ROUT2 Volume Control	ATT7	ATT6	ATT5	ATT4	ATT3	ATT2	ATT1	ATT0
06H	LOUT3 Volume Control	ATT7	ATT6	ATT5	ATT4	ATT3	ATT2	ATT1	ATT0
07H	ROUT3 Volume Control	ATT7	ATT6	ATT5	ATT4	ATT3	ATT2	ATT1	ATT0
08H	De-emphasis	0	0	DEMA1	DEMA0	DEMB1	DEMB0	DEMC1	DEMC0
09H	Reset	0	0	0	0	0	0	0	RSTN
0AH	Zero detect	OVFE	0	DZFM2	DZFM1	DZFM0	PWVRN	PWADN	PWDAN

Note: For addresses from 0BH to 1FH, data is not written.

When PDN goes to “L”, the registers are initialized to their default values.

When RSTN bit goes to “0”, the internal timing is reset and DZF1-2 pins go to “H”, but registers are not initialized to their default values.

SMUTE, DFS, SDOS and LOOP1 are ORed with pins.

■ Register Definitions

Addr	Register Name	D7	D6	D5	D4	D3	D2	D1	D0
00H	Control 1	0	0	0	0	DIF1	DIF0	0	SMUTE
	default	0	0	0	0	1	0	0	0

SMUTE: Soft Mute Enable

0: Normal operation

1: All DAC outputs soft-muted

Register bit of SMUTE is ORed with the SMUTE pin if P/S = "L".

DIF1-0: Audio Data Interface Modes (see table 7.)

Initial: "10", mode 2

Addr	Register Name	D7	D6	D5	D4	D3	D2	D1	D0
01H	Control 2	0	0	LOOP1	LOOP0	SDOS	DFS	ACKS	0
	default	0	0	0	0	0	0	0	0

ACKS: Master Clock Frequency Auto Setting Mode Enable

0: Disable, Manual Setting Mode

1: Enable, Auto Setting Mode

Master clock frequency is detected automatically at ACKS bit "1". In this case, the setting of DFS are ignored. When this bit is "0", DFS sets the sampling speed mode.

DFS: Sampling speed mode (see table 1.)

0: Normal speed

1: Double speed

Register bit of DFS is ORed with DFS pin if P/S = "L". The setting of DFS are ignored at ACKS bit "1".

SDOS: SDTO source select

0: ADC

1: DAUX

Register bit of SDOS is ORed with SDOS pin if P/S = "L".

LOOP1-0: Loopback mode enable

00: Normal (No loop back)

01: LIN → LOUT1, LOUT2, LOUT3

RIN → ROUT1, ROUT2, ROUT3

The digital ADC output (DAUX input if SDOS = "1") is connected to the digital DAC input. In this mode, the input DAC data to SDTI1-3 is ignored. The audio format of SDTO at loopback mode becomes mode 2 at mode 0, and mode 3 at mode 1, respectively.

10: SDTI1(L) → SDTI2(L), SDTI3(L)

SDTI1(R) → SDTI2(R), SDTI3(R)

In this mode the input DAC data to SDTI2-3 is ignored.

11: N/A

Register bit of LOOP1 is ORed with LOOP1 pin if P/S = "L".

Addr	Register Name	D7	D6	D5	D4	D3	D2	D1	D0
02H	LOUT1 Volume Control	ATT7	ATT6	ATT5	ATT4	ATT3	ATT2	ATT1	ATT0
03H	ROUT1 Volume Control	ATT7	ATT6	ATT5	ATT4	ATT3	ATT2	ATT1	ATT0
04H	LOUT2 Volume Control	ATT7	ATT6	ATT5	ATT4	ATT3	ATT2	ATT1	ATT0
05H	ROUT2 Volume Control	ATT7	ATT6	ATT5	ATT4	ATT3	ATT2	ATT1	ATT0
06H	LOUT3 Volume Control	ATT7	ATT6	ATT5	ATT4	ATT3	ATT2	ATT1	ATT0
07H	ROUT3 Volume Control	ATT7	ATT6	ATT5	ATT4	ATT3	ATT2	ATT1	ATT0
Default		0	0	0	0	0	0	0	0

ATT7-0: Attenuation Level (see table 9.)

Addr	Register Name	D7	D6	D5	D4	D3	D2	D1	D0
08H	De-emphasis	0	0	DEMA1	DEMA0	DEMB1	DEMB0	DEMC1	DEMC0
Default		0	0	0	1	0	1	0	1

DEMA1-0: De-emphasis response control for DAC1 data on SDTI1 (see table 6.)
Initial: "01", OFF

DEMB1-0: De-emphasis response control for DAC2 data on SDTI2 (see table 6.)
Initial: "01", OFF

DEMC1-0: De-emphasis response control for DAC3 data on SDTI3 (see table 6.)
Initial: "01", OFF

Addr	Register Name	D7	D6	D5	D4	D3	D2	D1	D0
09H	Clock mode	0	0	0	0	0	0	0	RSTN
	Default	0	0	0	0	0	0	0	1

RSTN: Internal timing reset

0: Reset. DZF1-2 pins go to "H", but registers are not initialized.

1: Normal operation

Addr	Register Name	D7	D6	D5	D4	D3	D2	D1	D0
0AH	Zero detect	OVFE	0	DZFM2	DZFM1	DZFM0	PWVRN	PWADN	PWDAN
	Default	0	0	1	1	1	1	1	1

PWDAN: Power-down control of DAC1-3

0: Power-down

1: Normal operation

PWADN: Power-down control of ADC

0: Power-down

1: Normal operation

PWVRN: Power-down control of reference voltage

0: Power-down

1: Normal operation

DZFM2-0: Zero detect mode select (see table 8.)

Initial: "111", disable

OVFE: Overflow detection enable

0: Disable, pin#33 becomes DZF2 pin.

1: Enable, pin#33 becomes OVF pin.

SYSTEM DESIGN

Figure 10 shows the system connection diagram. An evaluation board is available which demonstrates application circuits, the optimum layout, power supply arrangements and measurement results.

Condition: TVDD=5V, 3-wire serial control mode, CAD1-0 = "00", Full-differential input

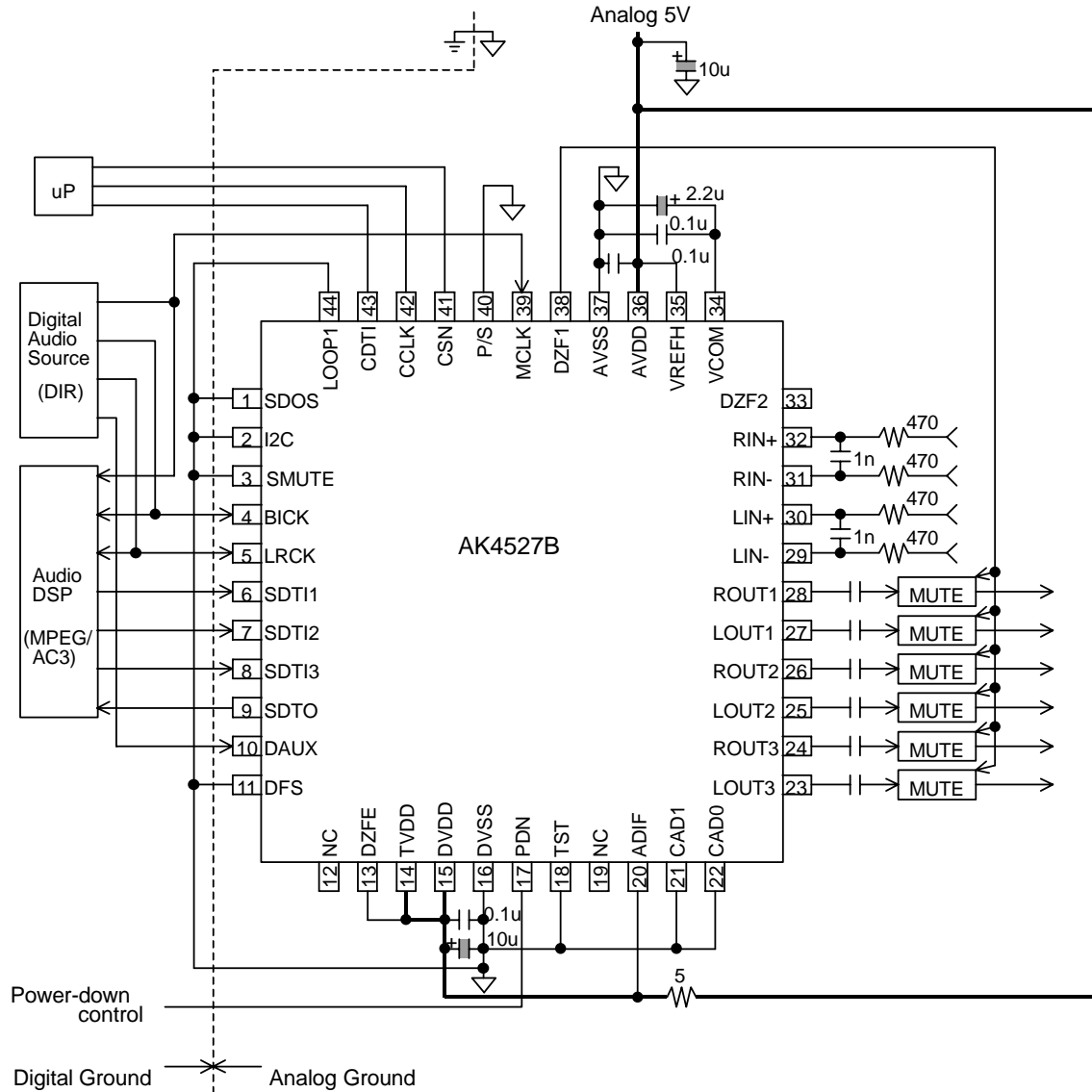

Figure 10. Typical Connection Diagram

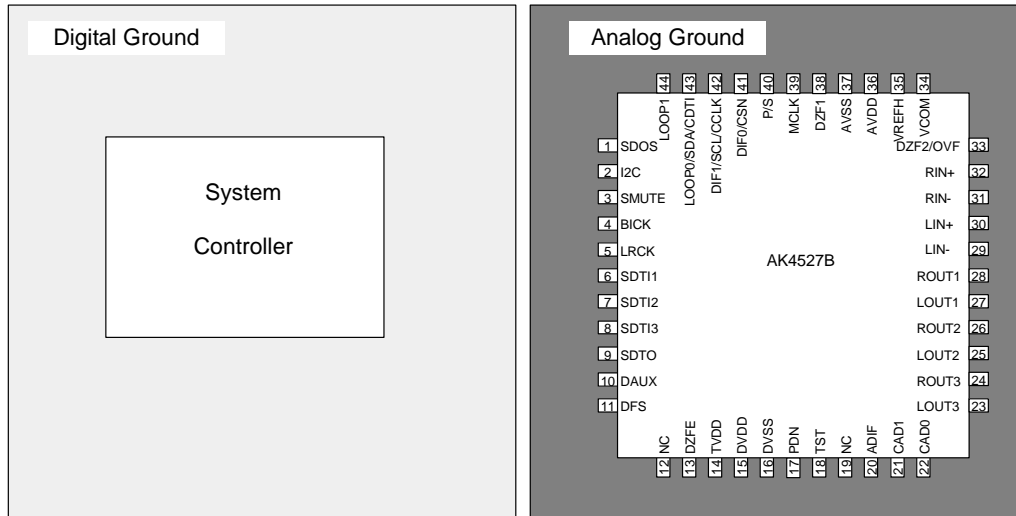

Figure 11. Ground Layout

Note: AVSS and DVSS must be connected to the same analog ground plane.

1. Grounding and Power Supply Decoupling

The AK4527B requires careful attention to power supply and grounding arrangements. AVDD and DVDD are usually supplied from analog supply in system. Alternatively if AVDD and DVDD are supplied separately, the power up sequence is not critical. **AVSS and DVSS of the AK4527B must be connected to analog ground plane.** System analog ground and digital ground should be connected together near to where the supplies are brought onto the printed circuit board. Decoupling capacitors should be as near to the AK4527B as possible, with the small value ceramic capacitor being the nearest.

2. Voltage Reference Inputs

The voltage of VREFH sets the analog input/output range. VREFH pin is normally connected to AVDD with a 0.1 μ F ceramic capacitor. VCOM is a signal ground of this chip. An electrolytic capacitor 2.2 μ F parallel with a 0.1 μ F ceramic capacitor attached to VCOM pin eliminates the effects of high frequency noise. No load current may be drawn from VCOM pin. All signals, especially clocks, should be kept away from the VREFH and VCOM pins in order to avoid unwanted coupling into the AK4527B.

3. Analog Inputs

The ADC inputs are differential. Figures 12 and 13 are circuit examples which analog signal is input by single end (ADIF= "L"). The signal can be input from either positive or negative input and the input signal range scales with the supply voltage and nominally 0.6 x VREFH Vpp. In case of single ended input, the distortion around full scale degrades compared with differential input (ADIF= "H"). Figures 14 and 15 are circuit examples which analog signal is input to both positive and negative input and the input signal range scales with the supply voltage and nominally 0.3 x VREFH Vpp. The AK4527B can accept input voltages from AVSS to AVDD. The ADC output data format is 2's complement. The output code is 7FFFFFFH(@24bit) for input above a positive full scale and 800000H(@24bit) for input below a negative full scale. The ideal code is 000000H(@24bit) with no input signal. The DC offset is removed by the internal HPF.

The AK4527B samples the analog inputs at 64fs. The digital filter rejects noise above the stop band except for multiples of 64fs. A simple RC filter ($f_c=150$ kHz) may be used to attenuate any noise around 64fs and most audio signals do not have significant energy at 64fs.

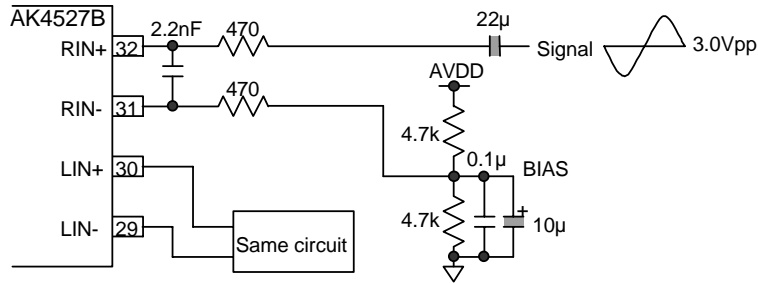

Figure 12. Single End Input Example (ADIF= "L"; Not using op-amp)

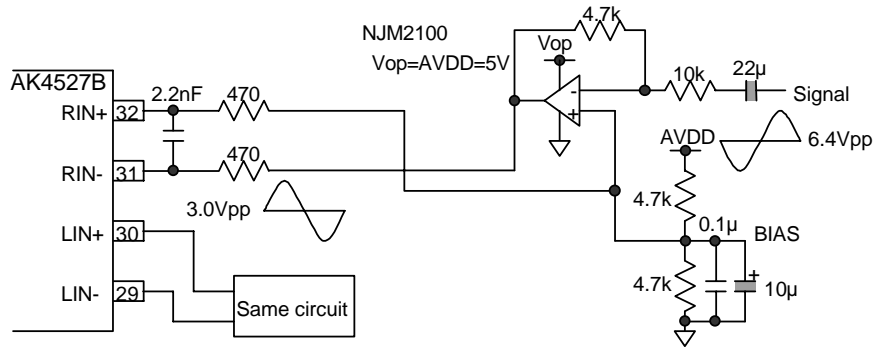

Figure 13. Single End Input Example (ADIF= "L"; Using op-amp)

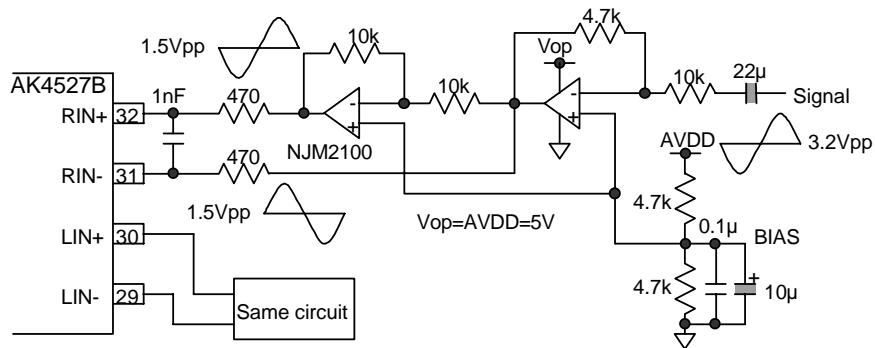

Figure 14. Differential Input Buffer Example (ADIF= "H"; Using op-amp with single power supply)

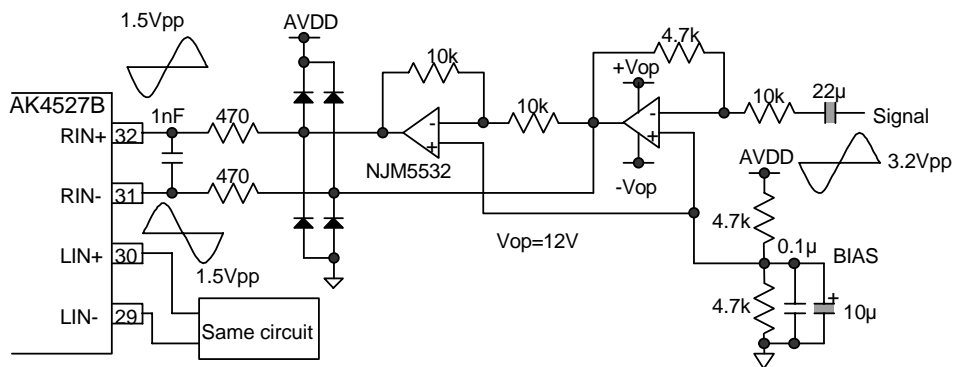

Figure 15. Differential Input Buffer Example (ADIF= "H"; Using op-amp with dual power supply)

4. Analog Outputs

The analog outputs are also single-ended and centered around the VCOM voltage. The input signal range scales with the supply voltage and nominally $0.6 \times V_{REFH}$ Vpp. The DAC input data format is 2's complement. The output voltage is a positive full scale for 7FFFFFFH(@24bit) and a negative full scale for 800000H(@24bit). The ideal output is VCOM voltage for 000000H(@24bit). The internal analog filters remove most of the noise generated by the delta-sigma modulator of DAC beyond the audio passband.

DC offsets on analog outputs are eliminated by AC coupling since DAC outputs have DC offsets of a few mV.

■ Peripheral I/F Example

The AK4527B can accept the signal of device with a nominal 3.3V supply because of TTL input. The power supply for output buffer (TVDD) of the AK4527B should be 3.3V when the peripheral devices operate at a nominal 3.3V supply. Figure 16 shows an example with the mixed system of 3.3V and 5V.

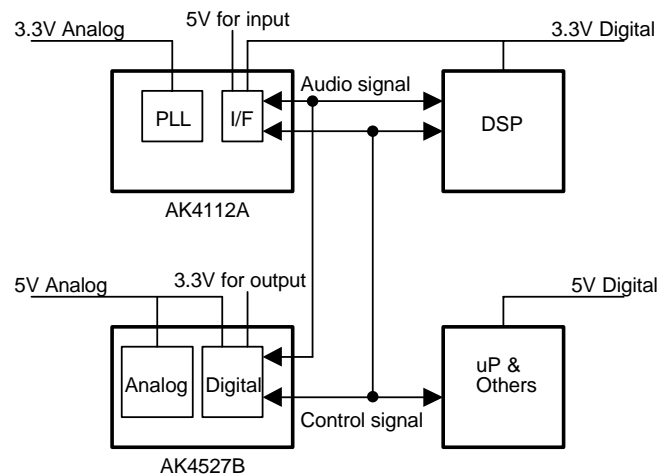

Figure 16. Power supply connection example

■ Applications

1) Zoran AC3 decoder, ZR38650

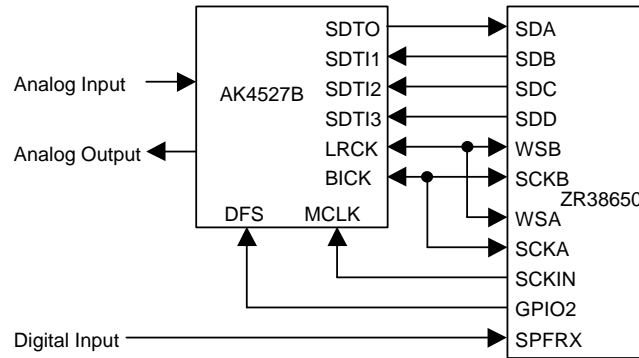

Figure 17. Application circuit example (ZR38650)

2) Yamaha AC3 decoder, YSS912

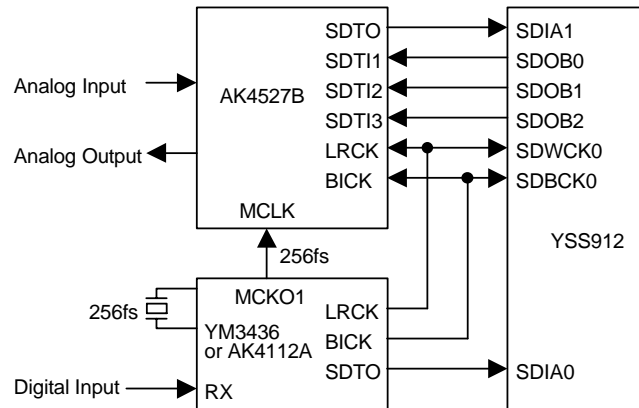

Figure 18. Application circuit example (YSS912)

3) Motorola AC3 decoder, DSP56362

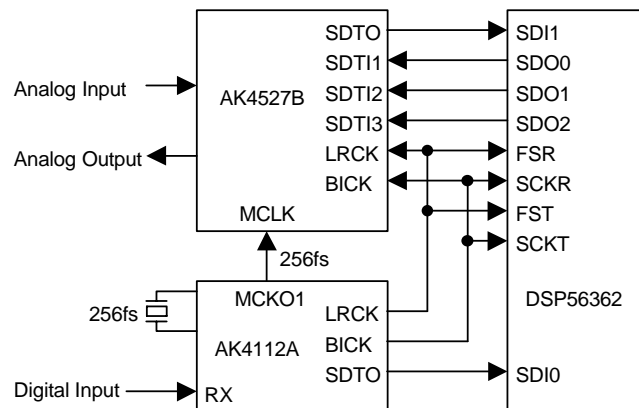
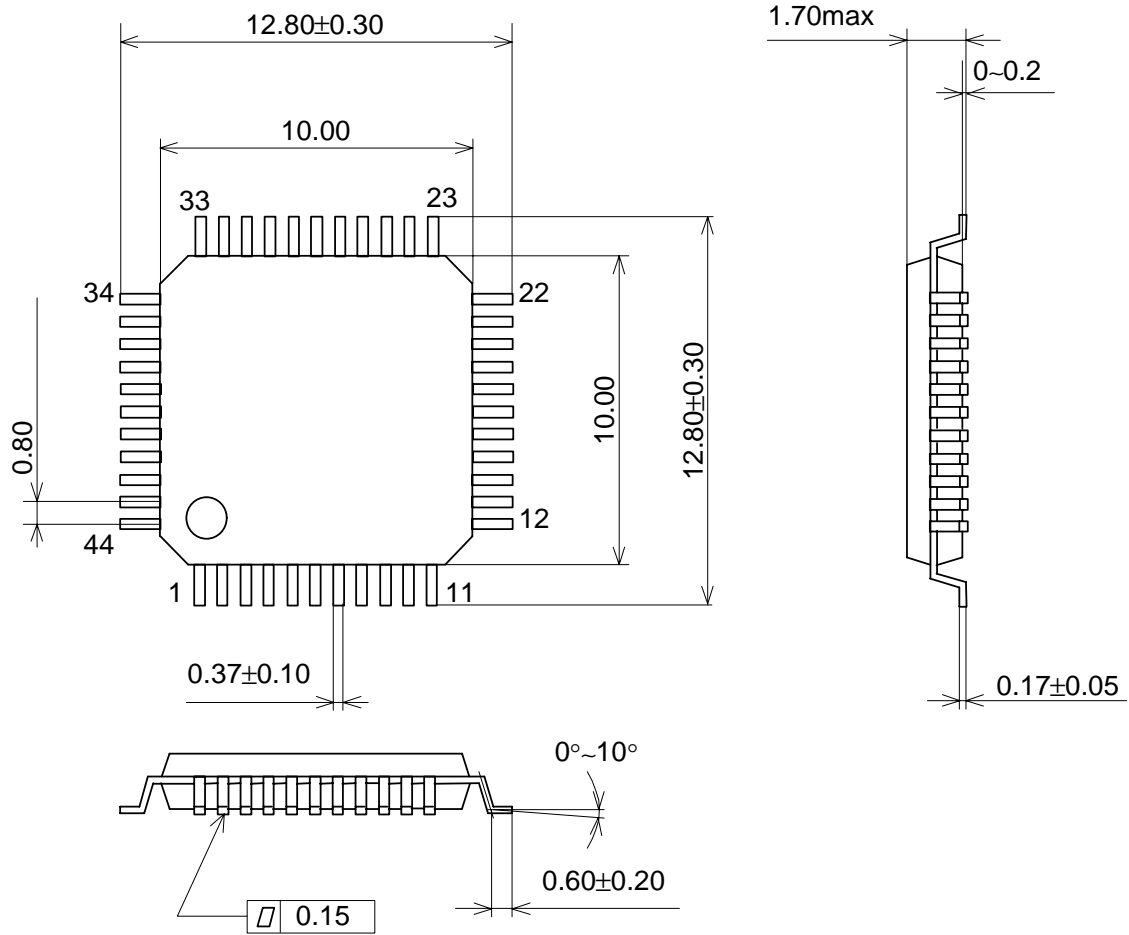

Figure 19. Application circuit example (DSP56362)

PACKAGE

44pin LQFP (Unit: mm)



■ Package & Lead frame material

Package molding compound:	Epoxy
Lead frame material:	Cu
Lead frame surface treatment:	Solder plate

MARKING

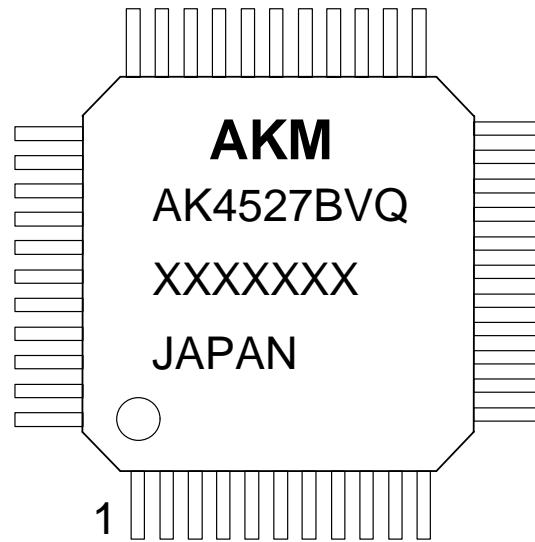

- 1) Pin #1 indication
- 2) Date Code: XXXXXXXX(7 digits)
- 3) Marking Code: AK4527BVQ
- 4) Country of Origin
- 5) Asahi Kasei Logo

IMPORTANT NOTICE

- These products and their specifications are subject to change without notice. Before considering any use or application, consult the Asahi Kasei Microsystems Co., Ltd. (AKM) sales office or authorized distributor concerning their current status.
- AKM assumes no liability for infringement of any patent, intellectual property, or other right in the application or use of any information contained herein.
- Any export of these products, or devices or systems containing them, may require an export license or other official approval under the law and regulations of the country of export pertaining to customs and tariffs, currency exchange, or strategic materials.
- AKM products are neither intended nor authorized for use as critical components in any safety, life support, or other hazard related device or system, and AKM assumes no responsibility relating to any such use, except with the express written consent of the Representative Director of AKM. As used here:
 - (a) A hazard related device or system is one designed or intended for life support or maintenance of safety or for applications in medicine, aerospace, nuclear energy, or other fields, in which its failure to function or perform may reasonably be expected to result in loss of life or in significant injury or damage to person or property.
 - (b) A critical component is one whose failure to function or perform may reasonably be expected to result, whether directly or indirectly, in the loss of the safety or effectiveness of the device or system containing it, and which must therefore meet very high standards of performance and reliability.
- It is the responsibility of the buyer or distributor of an AKM product who distributes, disposes of, or otherwise places the product with a third party to notify that party in advance of the above content and conditions, and the buyer or distributor agrees to assume any and all responsibility and liability for and hold AKM harmless from any and all claims arising from the use of said product in the absence of such notification.