



### Typical Applications

The HMC611 is ideal for:

- Cellular/PCS/3G
- WiMAX, WiBro, WLAN, Fixed Wireless & Radar
- Power Monitoring & Control Circuitry
- Receiver Signal Strength Indication (RSSI)
- Automatic Gain & Power Control

### Features

- Wide Dynamic Range: Up to 73 dB
- High Accuracy:  $\pm 1$  dB with 51 dB Range Up to 8 GHz
- Supply Voltage: +5V
- Excellent Stability over Temperature
- Buffered Temperature Sensor Output
- Die Size: 1.39 x 1.34 x 0.25 mm

### Functional Diagram

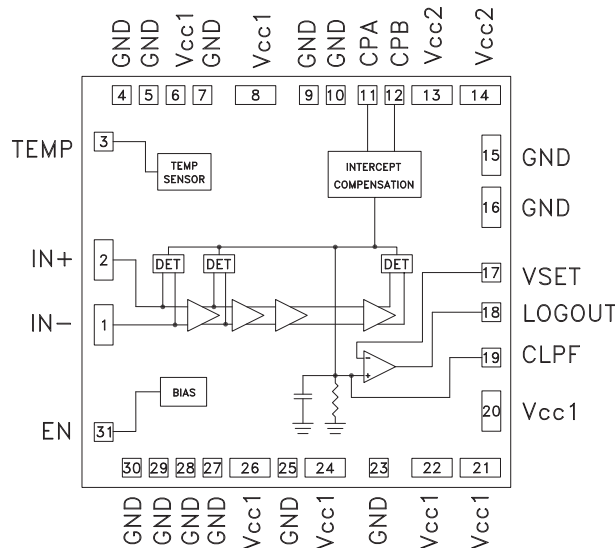

### General Description

The HMC611 Logarithmic Detector/Controller generates a voltage that is proportional to the log of the RF power envelop presented to its input. The HMC611 employs a successive compression topology which delivers extremely high dynamic range and conversion accuracy over a wide input frequency range. As the input power is increased, successive amplifiers move into saturation one by one creating an accurate approximation of the logarithm function. The output of a series of square law detectors is summed, converted into voltage domain and buffered to drive the LOGOUT output. For detection mode, the LOGOUT pin is shorted to the VSET input, and will provide a nominal logarithmic slope of -25 mV/dB and an intercept of 9 dBm (24 dBm for  $f \geq 5.8$  GHz). The HMC611 can also be used in the controller mode where an external voltage is applied to the VSET pin, to create an AGC or APC feedback loop.

### Electrical Specifications, $T_A = +25C^{(1)}$ , $V_{cc1} = 5V$ , $V_{cc2} = 5v$

Parameter	Typ.	Typ.	Typ.	Typ.	Typ.	Typ.	Typ.	Typ.	Typ.	Typ.	Typ.	Units
Input Frequency	50	100	900	1900	2200	3600	5800	7000	7500	8000	10000	MHz
$\pm 3$ dB Dynamic Range	71	71	72	72	72	73	63	64	62	61	51	dB
$\pm 3$ dB Dynamic Range Center	-35.5	-35.5	-35	-38	-37	-30.5	-20.5	-20	-21	-20.5	-18.5	dBm
$\pm 1$ dB Dynamic Range	62	62	61	62	62	65	57	56	55	51	42	dB
Output Slope	-25.5	-25.4	-25.2	-24.6	-24.7	-24.0	-24.2	-26	-26.8	-28.4	-32.7	mV/dB
Output Intercept	9.7	10.4	9.8	8.5	9.7	12.1	24.8	21.4	18.9	16.1	14.3	dBm
Temperature Sensitivity @ -10 dBm Input [2]	10.2	10.3	8.4	7.1	8.3	10.3	-8.9	2.4	3.3	7.0	18.3	$\times 10^{-3} \times \text{dBm}/C^\circ$

[1] Detector mode measurements; LOGOUT (Pin 18) is shorted to VSET (Pin 17).

[2] Measured from  $T_A = -55C$  to  $T_A = +85C$



## 60 dB, LOGARITHMIC DETECTOR / CONTROLLER, 1 - 10000 MHz

### Electrical Specifications, (continued)

Parameter	Conditions	Min.	Typ.	Max.	Units
<b>LOGOUT Interface</b>					
Output Voltage Range		0		Vcc -1.0	V
Output Rise Time/Fall Time	From 10% to 90%		2.5 / 57		μs
<b>VSET Interface</b>					
Input Impedance			30		kΩ
Input Voltage Range			0.25 to 1.35		V
Low Frequency Gain	VSET to LOGOUT		56		dB
Open Loop Corner Frequency [2]			700		kHz
<b>Power Down (EN) Interface</b>					
Voltage Range for Normal Mode		0.8 x Vcc [1]		Vcc [1]	V
Voltage Range for Powerdown Mode		0		0.2 x Vcc [1]	V
Threshold Voltage			Vcc [1]/2		V
<b>Power Supply (Vcc1, Vcc2)</b>					
Operating Voltage Range		4.5		5.5	V
Supply Current in Normal Mode			103	120	mA
Supply Current in Power Down Mode			1		mA

[1] Vcc = Vcc1 = Vcc2 = +5V

[2] This parameter describes the open loop gain bandwidth of the HMC611 output amplifier with no feedback from VSET to LOGOUT.

### Test Conditions

Parameter	Condition
Vcc1 = Vcc2	+5V
Input Zo - w/ 68 Ω Term Resistor at IN+	50 Ω
T <sub>A</sub>	+25 C
Fin (CW)	900 MHz

IN- Port connected to ground through a 1000pF capacitor

### Temperature Compensation Component Values Used at Key Application Frequencies with Vcc = +5V

Component	Frequency (MHz)										
	50	100	900	1900	2200	3600	5800	7000	7500	8000	10000
R8	562 Ω	562 Ω	562 Ω	562 Ω	562 Ω	562 Ω	562 Ω	562 Ω	562 Ω	0 Ω	0 Ω

#### LOGOUT Voltage & Error vs. Input Power, Fin = 50 MHz

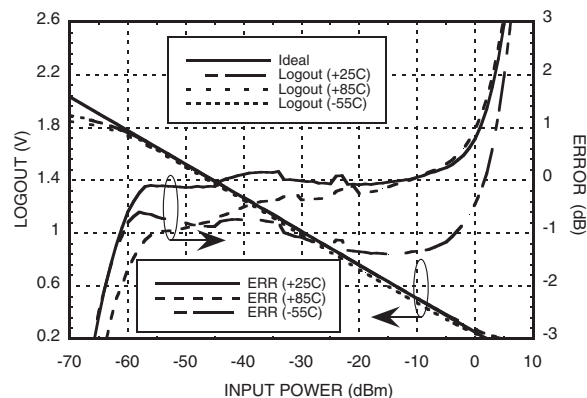

#### LOGOUT Voltage & Error vs. Input Power, Fin = 100 MHz

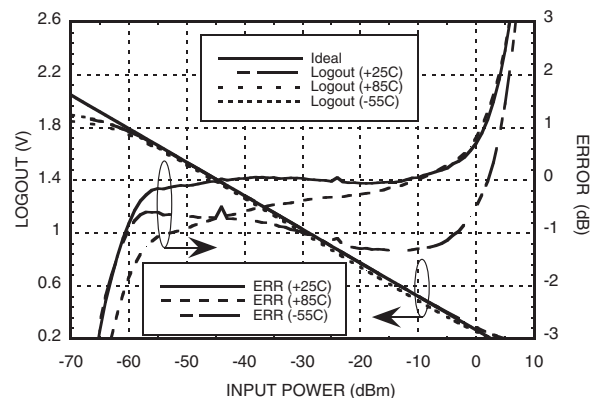

Unless otherwise noted: Vcc1, Vcc2 = +5V, T<sub>A</sub> = +25C

For price, delivery, and to place orders, please contact Hittite Microwave Corporation:  
20 Alpha Road, Chelmsford, MA 01824 Phone: 978-250-3343 Fax: 978-250-3373  
Order On-line at [www.hittite.com](http://www.hittite.com)



**60 dB, LOGARITHMIC  
DETECTOR / CONTROLLER, 1 - 10000 MHz**

**LOGOUT Voltage & Error  
vs. Input Power,  $f_{in} = 900$  MHz**

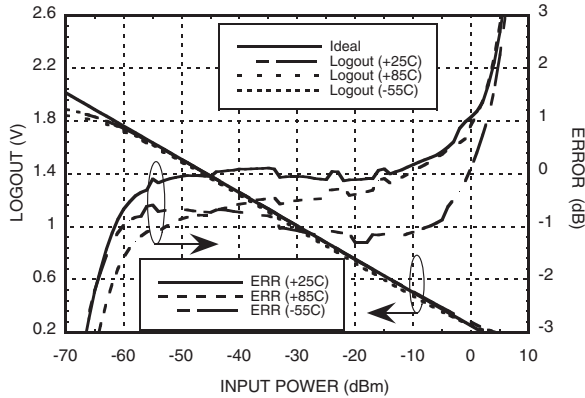

**LOGOUT Voltage & Error  
vs. Input Power,  $f_{in} = 1900$  MHz**

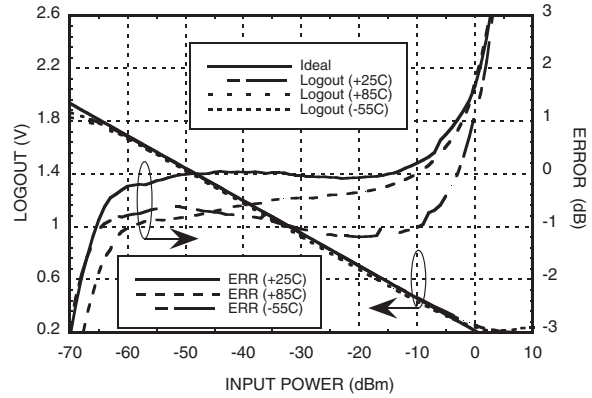

**LOGOUT Voltage & Error  
vs. Input Power,  $f_{in} = 2200$  MHz**

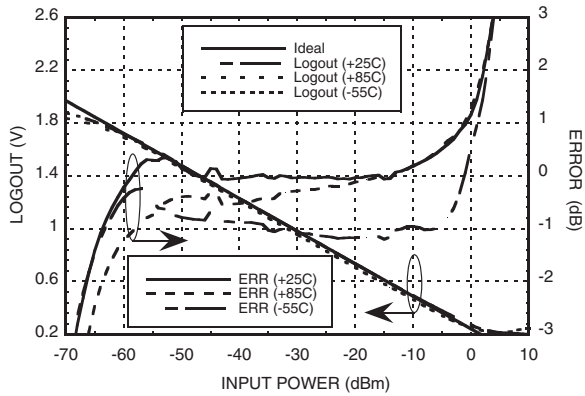

**LOGOUT Voltage & Error  
vs. Input Power,  $f_{in} = 3600$  MHz**

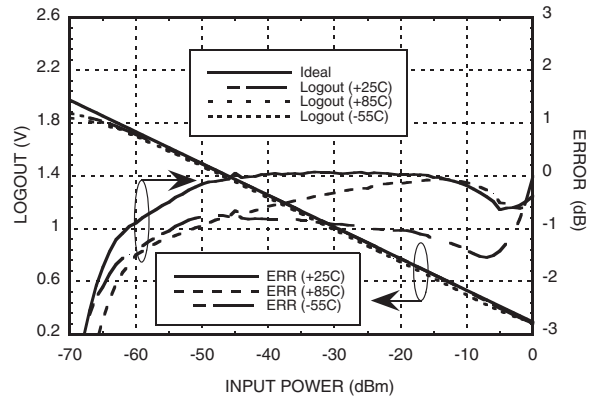

**LOGOUT Voltage & Error  
vs. Input Power,  $f_{in} = 5800$  MHz**

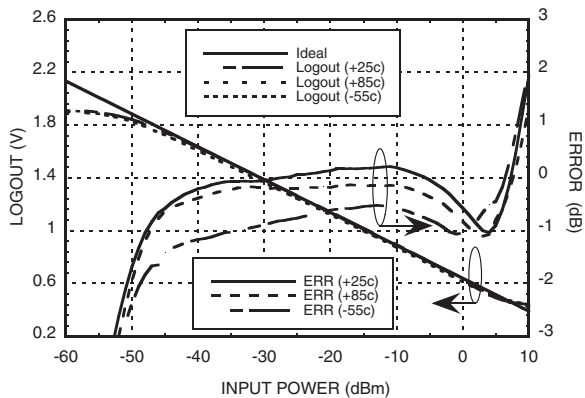

**LOGOUT Voltage & Error  
vs. Input Power,  $f_{in} = 7000$  MHz**

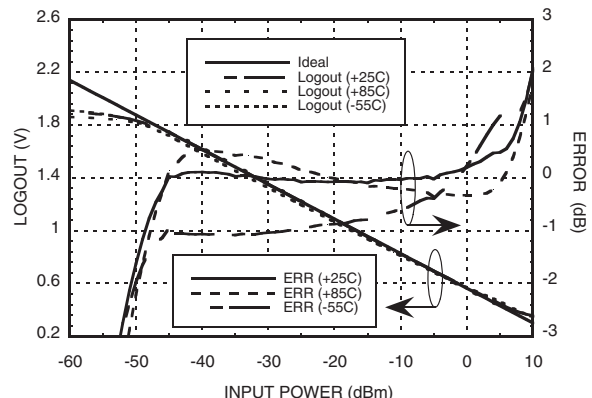

Unless otherwise noted:  $V_{cc1}, V_{cc2} = +5V, T_A = +25C$

For price, delivery, and to place orders, please contact Hittite Microwave Corporation:  
20 Alpha Road, Chelmsford, MA 01824 Phone: 978-250-3343 Fax: 978-250-3373  
Order On-line at [www.hittite.com](http://www.hittite.com)

## 60 dB, LOGARITHMIC DETECTOR / CONTROLLER, 1 - 10000 MHz

**LOGOUT Voltage & Error  
vs. Input Power,  $f_{in} = 7500$  MHz**

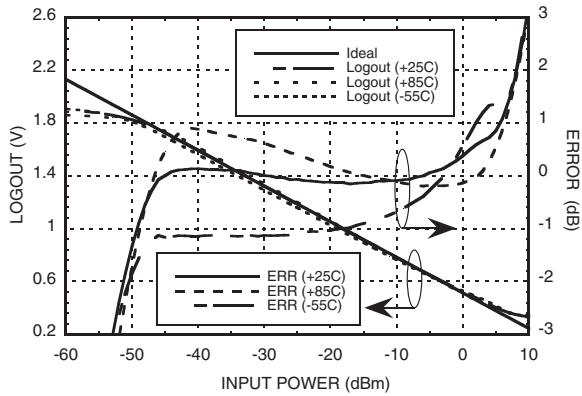

**LOGOUT Voltage & Error  
vs. Input Power,  $f_{in} = 8000$  MHz**

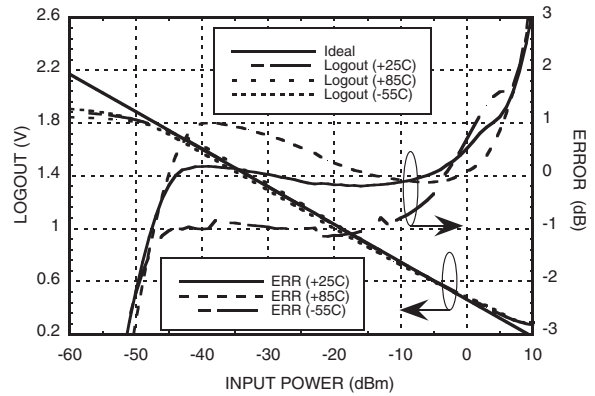

**LOGOUT Voltage & Error  
vs. Input Power,  $f_{in} = 10000$  MHz**

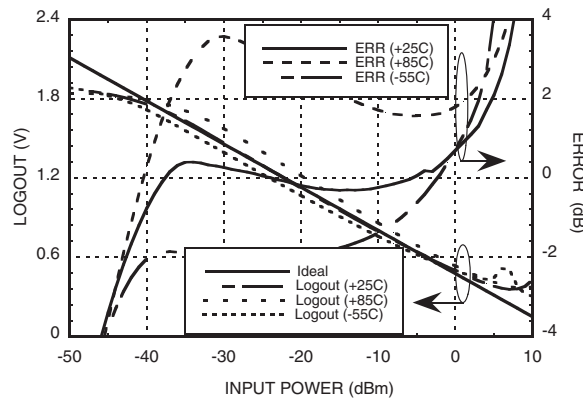

**LOGOUT Slope vs. Frequency**

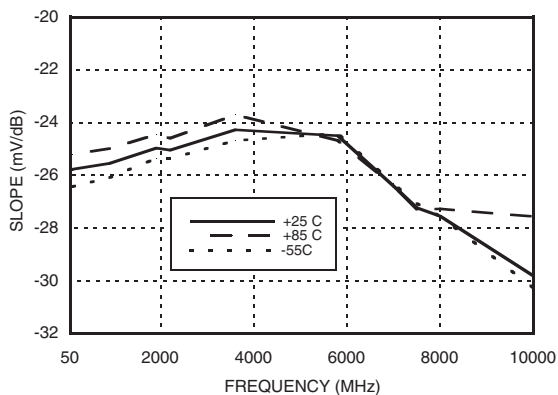

**LOGOUT Slope vs. Supply Voltage**

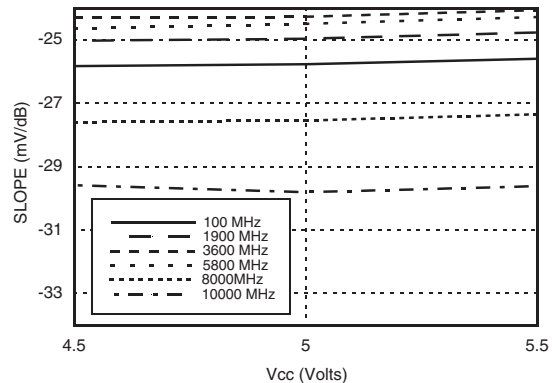

Unless otherwise noted:  $V_{cc1}, V_{cc2} = +5V, T_A = +25C$

For price, delivery, and to place orders, please contact Hittite Microwave Corporation:  
20 Alpha Road, Chelmsford, MA 01824 Phone: 978-250-3343 Fax: 978-250-3373  
Order On-line at [www.hittite.com](http://www.hittite.com)



**60 dB, LOGARITHMIC  
DETECTOR / CONTROLLER, 1 - 10000 MHz**

**LOGOUT Intercept vs. Frequency**

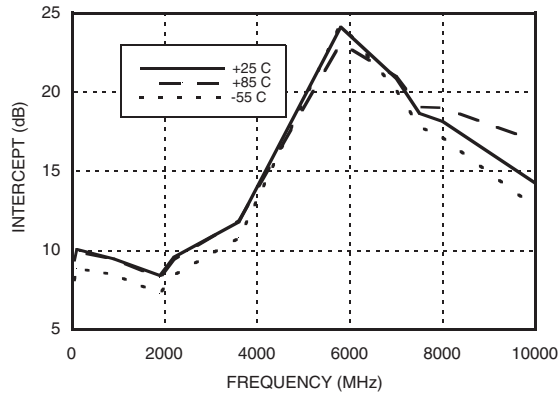

**LOGOUT Intercept vs. Supply Voltage**

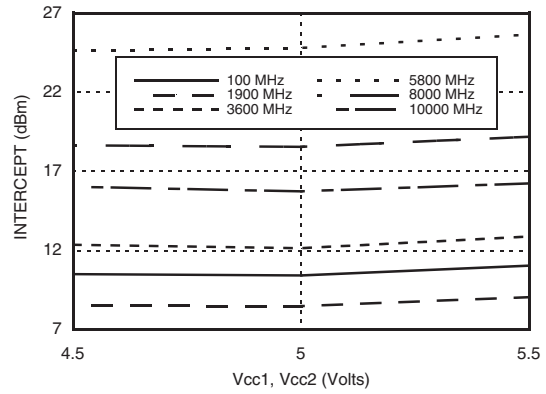

**LOGOUT Error vs. Input Power, Normalized [2], Fin= 1900 MHz**

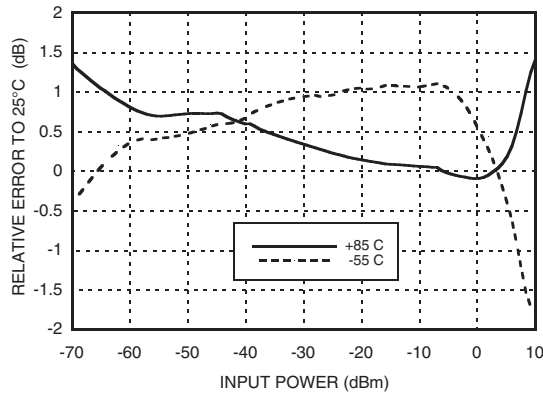

**Input Impedance vs Frequency [3]**

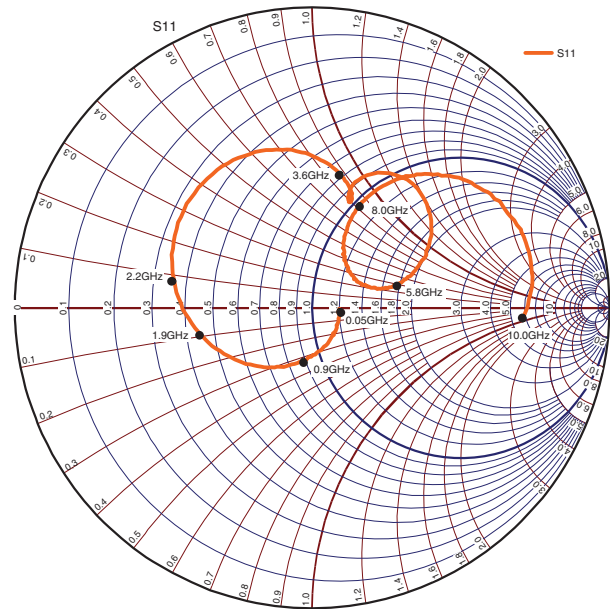

**LOGOUT Voltage vs. Input Power & Frequency**

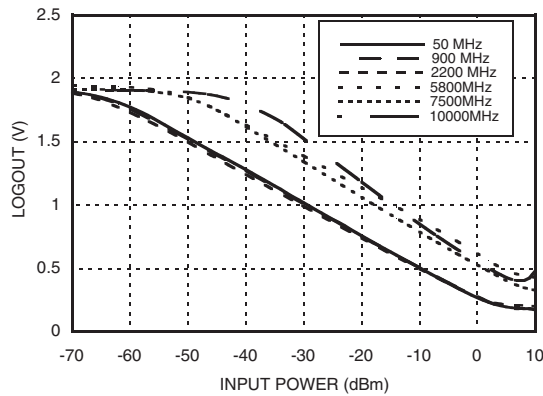

[1] Unless otherwise noted: Vcc1, Vcc2 = +5V, TA = +25C

[2] This data is relative to the room temperature performance of the HMC611

[3] Reference plane at input pad on test block

For price, delivery, and to place orders, please contact Hittite Microwave Corporation:  
20 Alpha Road, Chelmsford, MA 01824 Phone: 978-250-3343 Fax: 978-250-3373  
Order On-line at [www.hittite.com](http://www.hittite.com)



## 60 dB, LOGARITHMIC DETECTOR / CONTROLLER, 1 - 10000 MHz

### Absolute Maximum Ratings

Vcc1, Vcc2	+5.6V
EN	+5.6V
VSET Input Voltage	+5.6V
LOGOUT Output Current	3 mA
RF Input Power	+15 dBm
Junction Temperature	125 °C
Continuous Pdiss (T = 85°C) (Derate 21.6 mW/°C above 85°C)	0.86 Watts
Thermal Resistance (R <sub>th</sub> ) (junction to die bottom)	46.6 °C/W
Storage Temperature	-65 to +150 °C
Operating Temperature	-40 to +85 °C



ELECTROSTATIC SENSITIVE DEVICE  
OBSERVE HANDLING PRECAUTIONS

### Die Pad Dimensions

Pads	Pad Size
1, 2, 8, 13, 14, 15, 16, 20, 21, 22, 24, 26	.0024 [0.100] x .0052 [0.193]
3, 4, 5, 6, 7, 9, 10, 11, 12, 17, 18, 19, 23, 25, 27, 28, 29, 30, 31	.0024 [0.100] x .0024 [0.100]

### Outline Drawing

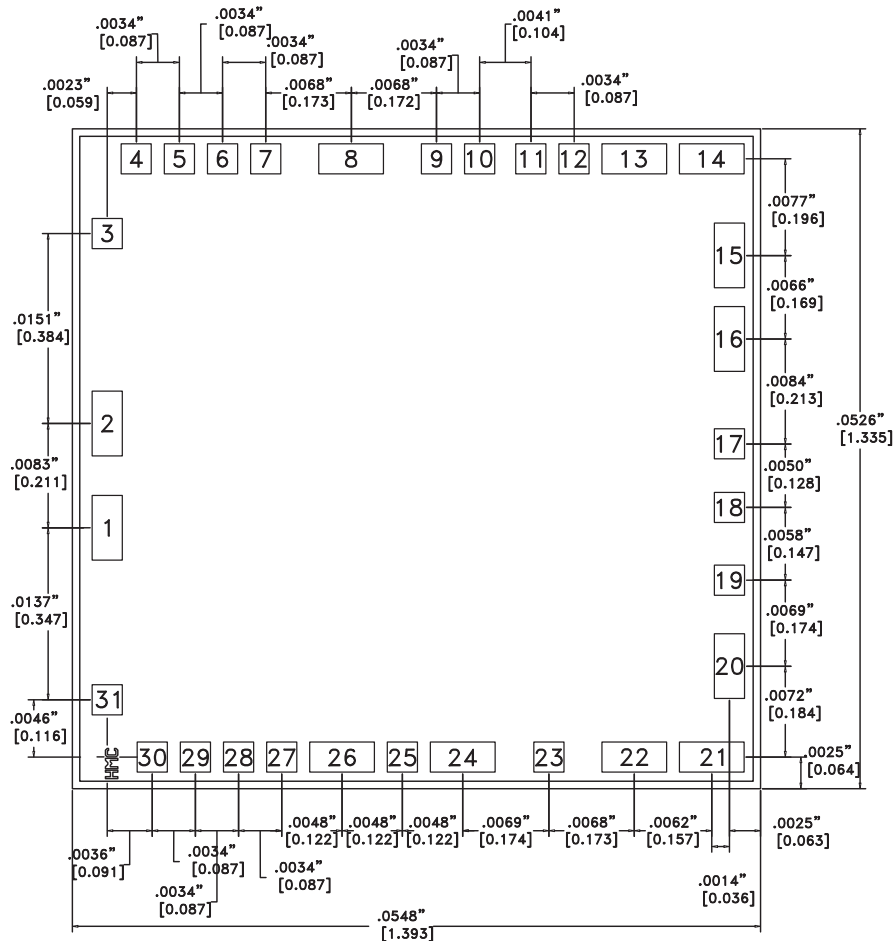

### Die Packaging Information [1]

Standard	Alternate
WP-3	[2]

[1] Refer to the "Packaging Information" section for die packaging dimensions.

[2] For alternate packaging information contact Hittite Microwave Corporation.

#### NOTES:



- ALL DIMENSIONS IN INCHES [MILLIMETERS]
- DIE THICKNESS IS 0.010 [0.25]
- TYPICAL BOND PAD IS 0.0024 SQUARE
- BOND PAD METALLIZATION: GOLD
- BACKSIDE METALLIZATION: GOLD
- BACKSIDE METAL IS GROUND
- NO CONNECTION REQUIRED FOR UNLABELED BOND PADS
- OVERALL DIE SIZE IS ±.002

For price, delivery, and to place orders, please contact Hittite Microwave Corporation:  
20 Alpha Road, Chelmsford, MA 01824 Phone: 978-250-3343 Fax: 978-250-3373  
Order On-line at [www.hittite.com](http://www.hittite.com)

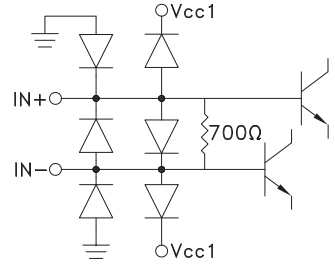
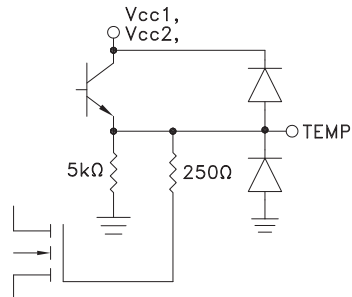

## 60 dB, LOGARITHMIC DETECTOR / CONTROLLER, 1 - 10000 MHz

### Pad Descriptions

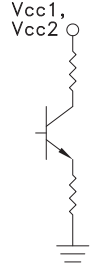
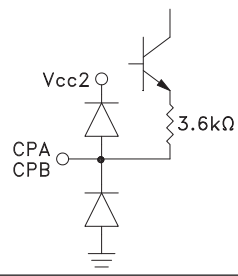
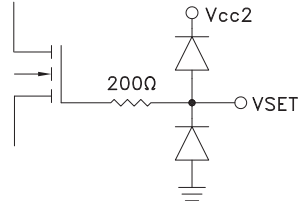
Pad Number	Function	Description	Interface Schematic
1, 2	IN-, IN+	RF Input pads. Connect RF to IN+, and AC couple IN- to ground for single-ended operation.	
3	TEMP	Temperature sensor output pin	
4, 5, 7, 9, 10, 15, 16, 23, 25, 27-30 Die Bottom	GND	Die bottom must be connected to RF and DC ground.	
6, 8, 13, 14, 20-22, 24, 26	Vcc1, Vcc2	Bias supply. Connect supply voltage to these pins with appropriate filtering.	
11, 12	CPA, CPB	Temperature compensation pins.	
17	VSET	VSET input in controller mode. Short this pin to LOGOUT for detector mode.	

For price, delivery, and to place orders, please contact Hittite Microwave Corporation:  
 20 Alpha Road, Chelmsford, MA 01824 Phone: 978-250-3343 Fax: 978-250-3373  
 Order On-line at [www.hittite.com](http://www.hittite.com)

### Pad Descriptions (Continued)

Pad Number	Function	Description	Interface Schematic
18	LOGOUT	Logarithmic output that converts the input power to a DC level in detector mode. Short this pin to VSET for detector mode.	
19	CLPF	Loop filter capacitor for output ripple filtering.	
31	EN	Enable pad, connect to Vcc1 or Vcc2 for normal operation. Applying voltage $<0.2 \times (V_{cc1}, V_{cc2})$ will initiate power saving mode.	





**60 dB, LOGARITHMIC  
DETECTOR / CONTROLLER, 1 - 10000 MHz**

**Application Circuit**

Note 1: For detector mode, connect high impedance volt meter to the LOGOUT port. LOGOUT is shorted to VSET, as required for detector mode.

Note 2: For controller mode, remove short between LOGOUT and VSET. In controller mode, the LOGOUT output can be used to drive a variable gain amplifier, or a variable attenuator, either directly or through a buffer or microcontroller. VSET should be connected to an external control voltage, typically between +0.6 and +1.9V.

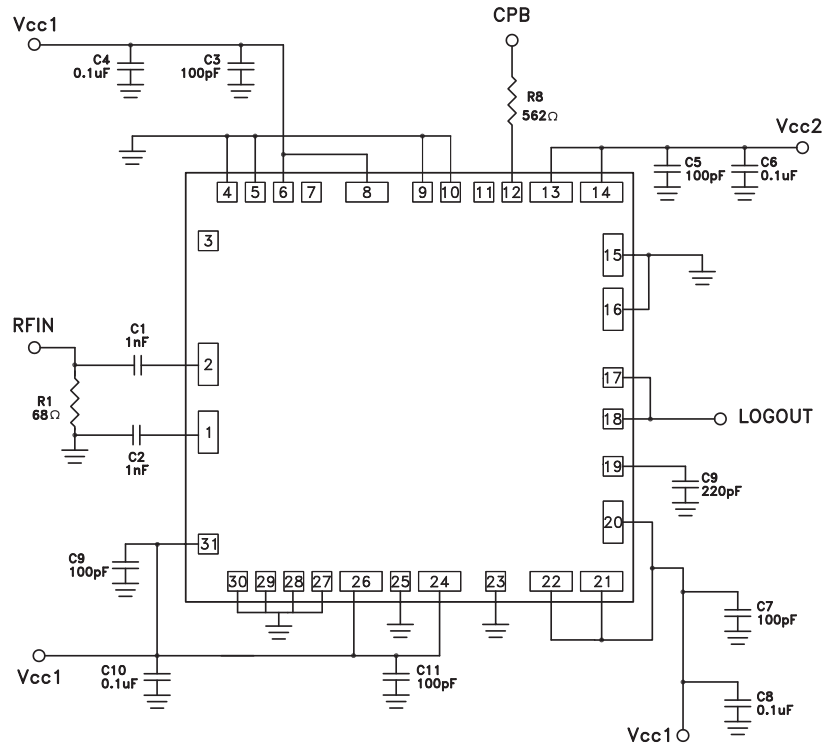

**Assembly Diagram**

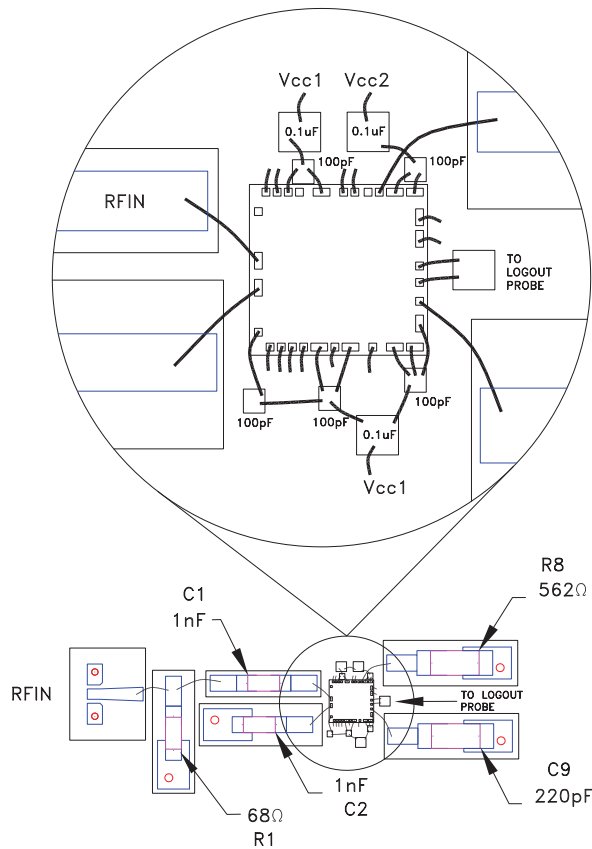

For price, delivery, and to place orders, please contact Hittite Microwave Corporation:  
20 Alpha Road, Chelmsford, MA 01824 Phone: 978-250-3343 Fax: 978-250-3373  
Order On-line at [www.hittite.com](http://www.hittite.com)

**60 dB, LOGARITHMIC  
DETECTOR / CONTROLLER, 1 - 10000 MHz**

**Mounting & Bonding Techniques for Millimeterwave GaAs MMICs**

The die should be attached directly to the ground plane eutectically or with conductive epoxy (see HMC general Handling, Mounting, Bonding Note).

50 Ohm Microstrip transmission lines on 0.127mm (5 mil) thick alumina thin film substrates are recommended for bringing RF to and from the chip (Figure 1). If 0.254mm (10 mil) thick alumina thin film substrates must be used, the die should be raised 0.150mm (6 mils) so that the surface of the die is coplanar with the surface of the substrate. One way to accomplish this is to attach the 0.102mm (4 mil) thick die to a 0.150mm (6 mil) thick molybdenum heat spreader (moly-tab) which is then attached to the ground plane (Figure 2).

Microstrip substrates should be placed as close to the die as possible in order to minimize bond wire length. Typical die-to-substrate spacing is 0.076mm to 0.152 mm (3 to 6 mils).

**Handling Precautions**

Follow these precautions to avoid permanent damage.

**Storage:** All bare die are placed in either Waffle or Gel based ESD protective containers, and then sealed in an ESD protective bag for shipment. Once the sealed ESD protective bag has been opened, all die should be stored in a dry nitrogen environment.

**Cleanliness:** Handle the chips in a clean environment. DO NOT attempt to clean the chip using liquid cleaning systems.

**Static Sensitivity:** Follow ESD precautions to protect against ESD strikes.

**Transients:** Suppress instrument and bias supply transients while bias is applied. Use shielded signal and bias cables to minimize inductive pick-up.

**General Handling:** Handle the chip along the edges with a vacuum collet or with a sharp pair of bent tweezers. The surface of the chip has fragile air bridges and should not be touched with vacuum collet, tweezers, or fingers.

**Mounting**

The chip is back-metallized and can be die mounted with AuSn eutectic preforms or with electrically conductive epoxy. The mounting surface should be clean and flat.

**Eutectic Die Attach:** A 80/20 gold tin preform is recommended with a work surface temperature of 255 °C and a tool temperature of 265 °C. When hot 90/10 nitrogen/hydrogen gas is applied, tool tip temperature should be 290 °C. DO NOT expose the chip to a temperature greater than 320 °C for more than 20 seconds. No more than 3 seconds of scrubbing should be required for attachment.

**Epoxy Die Attach:** Apply a minimum amount of epoxy to the mounting surface so that a thin epoxy fillet is observed around the perimeter of the chip once it is placed into position. Cure epoxy per the manufacturer's schedule.

**Wire Bonding**

RF bonds made with two 1 mil wires are recommended. These bonds should be thermosonically bonded with a force of 40-60 grams. DC bonds of 0.001" (0.025 mm) diameter, thermosonically bonded, are recommended. Ball bonds should be made with a force of 40-50 grams and wedge bonds at 18-22 grams. All bonds should be made with a nominal stage temperature of 150 °C. A minimum amount of ultrasonic energy should be applied to achieve reliable bonds. All bonds should be as short as possible, less than 12 mils (0.31 mm).

