

FEATURES

1. This specification shall be applied to photocoupler. Model No. CNY17F-1 / CNY17F-2 / CNY17F-3 / CNY17F-4 as an option.
2. Applicable Models (Business dealing name)
 - * Dual-in-line package :
CNY17F-1-V / CNY17F-2-V / CNY17F-2-V / CNY17F-4-V
 - * Wide lead spacing package :
CNY17F-1M-V / CNY17F-2M-V / CNY17F-3M-V / CNY17F-4M-V
 - * Surface mounting package :
CNY17F-1S-V / CNY17F-2S-V / CNY17F-3S-V / CNY17F-4S-V
 - * Tape and reel packaging :
CNY17F-1STA-V / CNY17F-2STA-V / CNY17F-3STA-V / CNY17F-4STA-V
CNY17F-1STA1-V / CNY17F-2STA1-V / CNY17F-3STA1-V / CNY17F-4STA1-V
3. The relevant models are the models Approved by VDE according to DIN VDE 0884:1992-06

Approved Model No.: CNY17F-1 / CNY17F-2 / CNY17F-3 / CNY17F-4 ;
CNY17F-1M / CNY17F-2M / CNY17F-3M / CNY17F-4M ;
CNY17F-1S / CNY17F-2S / CNY17F-3S / CNY17F-4S

VDE approved No.: 094722

(According to the specification DIN VDE 0884:1992-06)

- * Operating isolation voltage V_{IORM} : 850V (Peak)
- * Transient voltage V_{TR} : 6000V (Peak)
- * Pollution : 2 (According to VDE 0110-1 : 1997-04)
- * Clearances distance (Between input and output) : 7.0mm (MIN.)
- * Creepage distance (Between input and output) : 7.0mm (MIN.)
- * Isolation thickness between input and output : 0.4mm (MIN.)
- * Safety limit values
Current (Isi) : 400mA (Diode side)
Power (Psi) : 700mW (Phototransistor side)
Temperature(Tsi) : 175°C

In order to keep safety electric isolation of photocoupler, please set the protective circuit to keep within safety limit values when the actual application equipment troubled.

- * Indication of VDE 0884 approval prints "  " on sleeve package.

OUTLINE DIMENSIONS

Dual-in-line package :

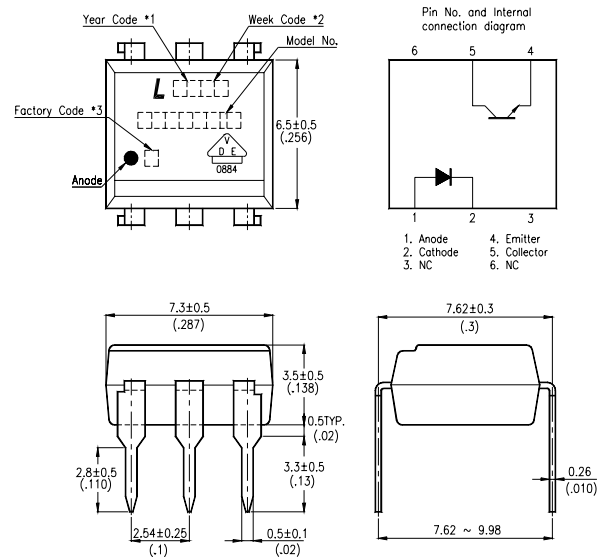

Wide lead spacing package:

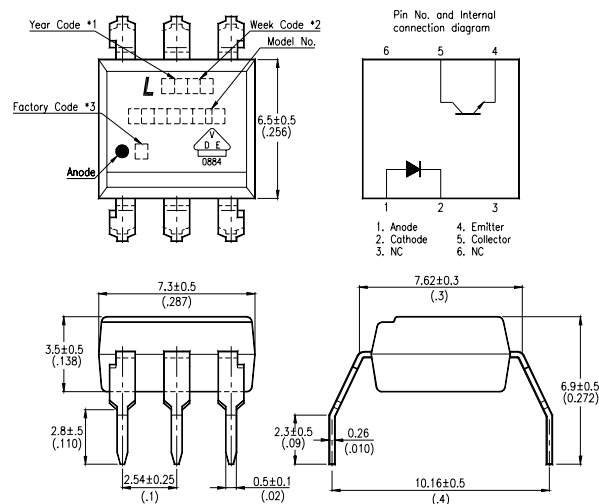

- *1. Year date code.
- *2. 2-digit work week.
- *3. Factory identification mark shall be marked (Z : Taiwan, Y : Thailand).
- *4. Model No.: CNY17F-1, CNY17F-2, CNY17F-3, CNY17F-4

OUTLINE DIMENSIONS

Surface mounting package :

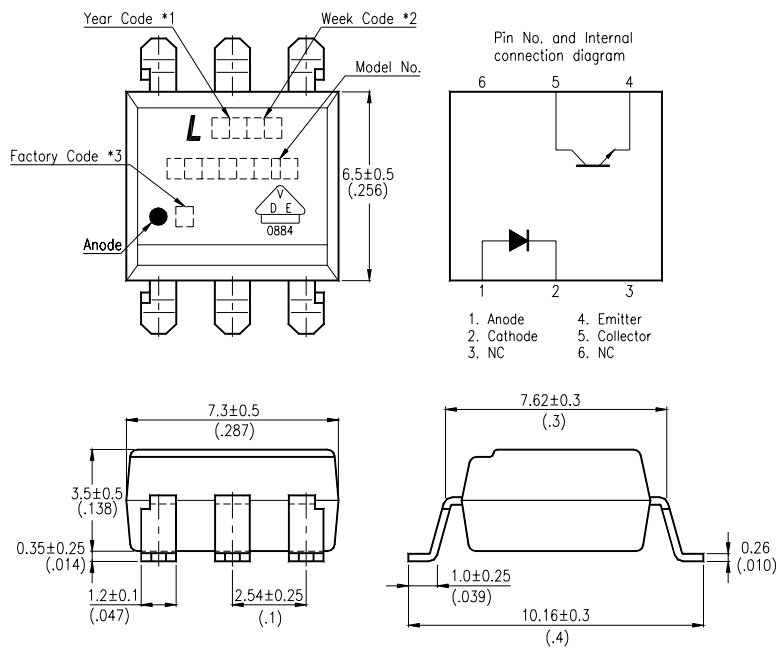

- *1. Year date code.
- *2. 2-digit work week.
- *3. Factory identification mark shall be marked (Z : Taiwan, Y : Thailand).
- *4. Model No.: CNY17F-1, CNY17F-2, CNY17F-3, CNY17F-4

TAPING DIMENSIONS

Tape and reel package (TYPE I) :

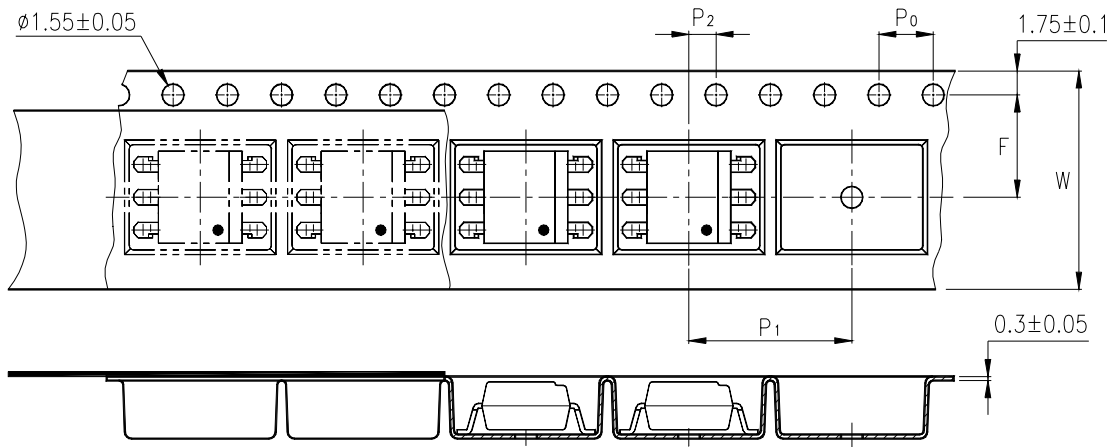

Tape and reel package (TYPE II) :

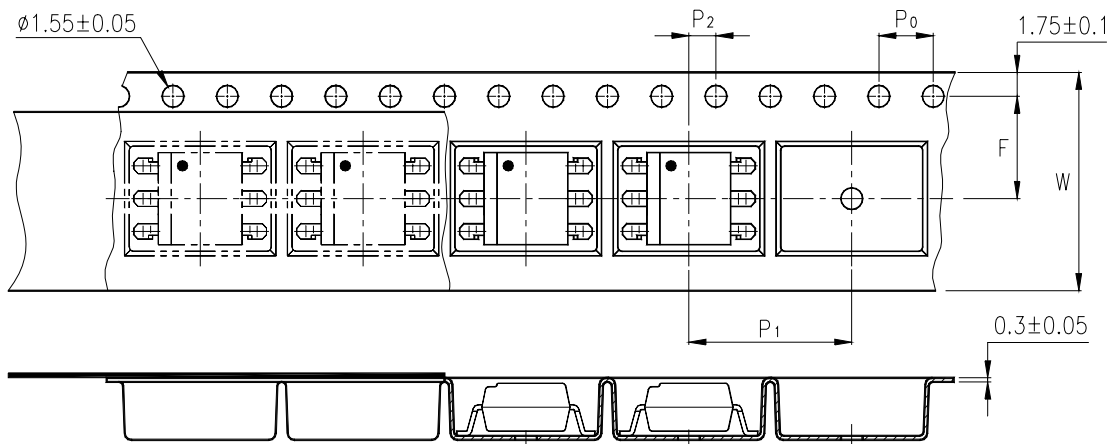

Description	Symbol	Dimensions in mm (inches)
Tape wide	W	16 ± 0.3 (.63)
Pitch of sprocket holes	P_0	4 ± 0.1 (.15)
Distance of compartment	F	7.5 ± 0.1 (.295)
	P_2	2 ± 0.1 (.079)
Distance of compartment to compartment	P_1	12 ± 0.1 (.472)

ABSOLUTE MAXIMUM RATING

(Ta = 25°C)

PARAMETER		SYMBOL	RATING	UNIT
INPUT	Forward Current	I _F	60	mA
	Reverse Voltage	V _R	6	V
	Power Dissipation	P	100	mW
OUTPUT	Collector - Emitter Voltage	V _{CEO}	70	V
	Emitter - Collector Voltage	V _{ECO}	7	V
	Collector Current	I _C	150	mA
	Collector Power Dissipation	P _C	150	mW
Total Power Dissipation		P _{tot}	250	mW
*1	Isolation Voltage	V _{iso}	5,000	V _{rms}
Operating Temperature		T _{opr}	-55 ~ +100	°C
Storage Temperature		T _{stg}	-55 ~ +150	°C
*2	Soldering Temperature	T _{sol}	260	°C

*1. AC For 1 Minute, R.H. = 40 ~ 60%

Isolation voltage shall be measured using the following method.

- (1) Short between anode and cathode on the primary side and between collector, emitter and base on the secondary side.
- (2) The isolation voltage tester with zero-cross circuit shall be used.
- (3) The waveform of applied voltage shall be a sine wave.

*2. For 10 Seconds

ELECTRICAL - OPTICAL CHARACTERISTICS

(Ta = 25°C)

PARAMETER		SYMBOL	MIN.	TYP.	MAX.	UNIT	CONDITIONS	
INPUT	Forward Voltage	V _F	—	1.45	1.65	V	I _F =60mA	
	Reverse Current	I _R	—	—	10	μA	V _R =6V	
	Terminal Capacitance	C _t	—	—	100	pF	V=0, f=1MHz	
OUTPUT	Collector Dark Current	I _{CEO}	—	—	50	nA	V _{CE} =10V, I _F =0	
	Collector-Emitter Breakdown Voltage	BV _{CEO}	70	—	—	V	I _C =0.1mA I _F =0	
	Emitter-Collector Breakdown Voltage	BV _{ECO}	7	—	—	V	I _E =10μA I _F =0	
TRANSFER CHARACTERISTICS	Current * Transfer Ratio	CNY17F-1-V	CTR	40	—	80	%	I _F =10mA V _{CE} =5V
		CNY17F-2-V		63	—	125		
		CNY17F-3-V		100	—	200		
		CNY17F-4-V		160	—	320		
	Collector-Emitter Saturation Voltage	V _{CE(sat)}	—	—	0.3	V	I _F =10mA I _C =2.5mA	
	Isolation Resistance	R _{iso}	100	—	—	GΩ	DC500V 40 ~ 60% R.H.	
	Floating Capacitance	C _f	—	—	2	pF	V=0, f=1MHz	
	Response Time (Rise)	t _r	—	5	10	μs	V _{CC} =10V, I _C =2mA R _L =100Ω	
	Response Time (Fall)	t _r	—	5	10	μs		

$$* CTR = \frac{I_C}{I_F} \times 100\%$$

ISOLATION SPECIFICATION ACCORDING TO VDE 0884

Parameter	Symbol	Conditions	Rating	Unit	Remark
Class of environmental test	-	DIN IEC68	55/100/21	-	
Pollution	-	DIN VDE0110	2	-	
Maximum Operating Isolation Voltage	V_{IORM}	-	850	V_{PEAK}	Refer to the Diagram 1, 2
Partial Discharge Test Voltage (Between Input and Output)	Diagram 1	$t_p=60s, q_c<5pC$	1275	V_{PEAK}	
	Diagram 2	$t_p=1s, q_c<5pC$	1594	V_{PEAK}	
Maximum Over-voltage	$V_{INITIAL}$	$t_{NI} = 10s$	6000	V_{PEAK}	
Safety Maximum Ratings					
1) Case Temperature	T_{si}	$I_F = 0, P_c = 0$	175	$^{\circ}C$	Refer to the Figure 1, 3
2) Input Current	I_{si}	$P_c=0$	400	mA	
3) Electric Power (Output or Total Power Issipation)	P_{si}	-	700	mW	
Isolation Resistance (Test Voltage Between Input and Output : DC500V)	R_{ISO}	$T_a=T_{si}$	MIN. 10^9	Ω	
		$T_a=T_{opr}(MAX.)$	MIN. 10^{11}		
		$T_a=25^{\circ}C$	MIN. 10^{12}		

Precautions in performing isolation test

* Partial discharge test methods shall be the ones according to the specifications of VDE 0884:1992-06

* Please don't carry out isolation test (V_{iso}) over $V_{INITIAL}$. This product deteriorates isolation characteristics by partial discharge due to applying high voltage (ex. $V_{INITIAL}$). And there is possibility that this product occurs partial discharge in operating isolation voltage (V_{IORM})

PARTIAL DISCHARGE TEST METHOD

Method (A) for type testing and random testing.

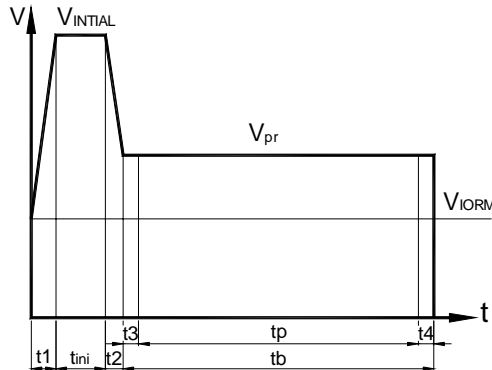

t_1, t_2 = 1 to 10s
 t_3, t_4 = 1s
 t_p (Partial Discharge Measuring Time) = 60s
 t_b = 62s
 t_{ini} = 10s

Method (B) for routine testing.

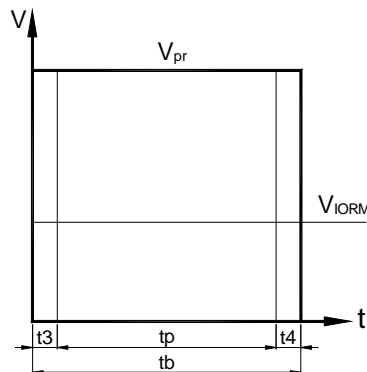

t_3, t_4 = 0.1s
 t_p (Partial Discharge Measuring Time) = 1s
 t_b = 1.2s

The partial discharge level shall not exceed 5 pC during the partial discharge measuring time interval t_p under the test conditions shown above.

CHARACTERISTICS CURVES

Fig.1 Forward Current vs. Ambient Temperature

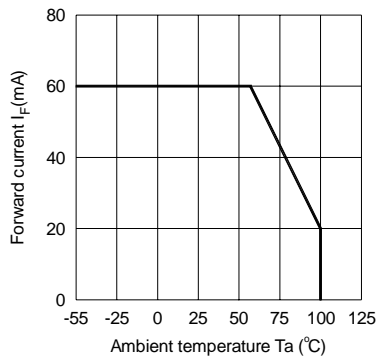

Fig.2 Collector Power Dissipation vs. Ambient Temperature

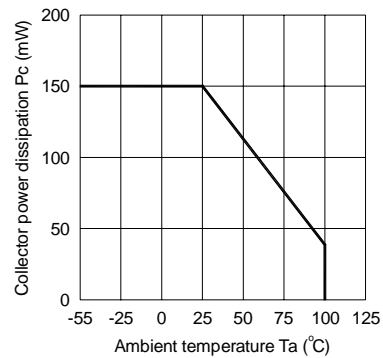

Fig.3 Collector-emitter Saturation Voltage vs. Forward Current

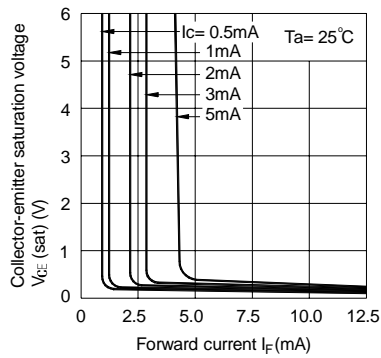

Fig.4 Forward Current vs. Forward Voltage

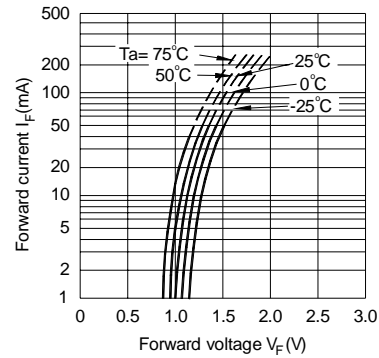

Fig.5 Current Transfer Ratio vs. Forward Current

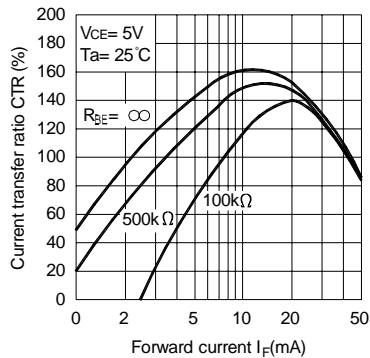
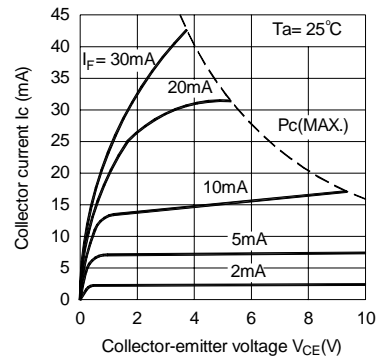

Fig.6 Collector Current vs. Collector-emitter Voltage



CHARACTERISTICS CURVES

Fig.7 Relative Current Transfer Ratio vs. Ambient Temperature

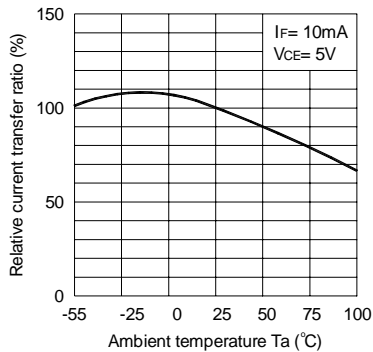

Fig.8 Collector-emitter Saturation Voltage vs. Ambient Temperature

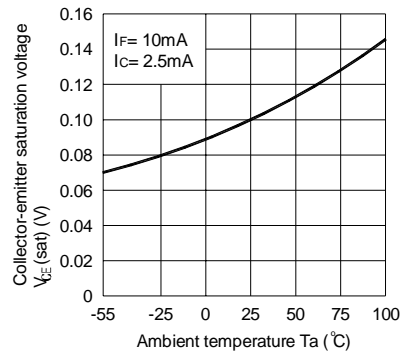

Fig.9 Collector Dark Current vs. Ambient Temperature

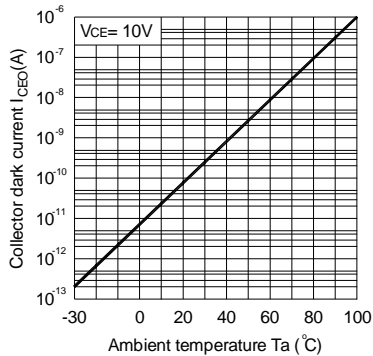

Fig.10 Response Time vs. Load Resistance

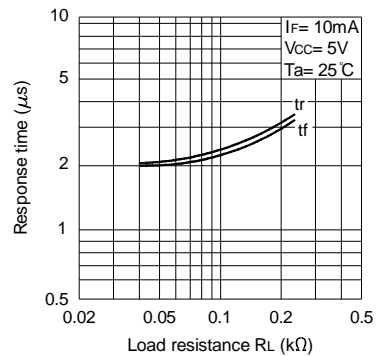
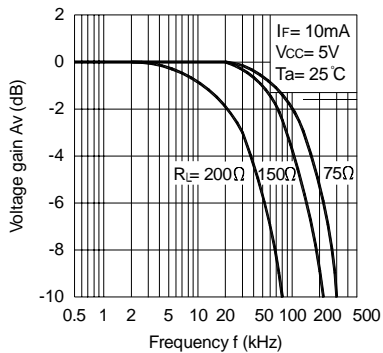
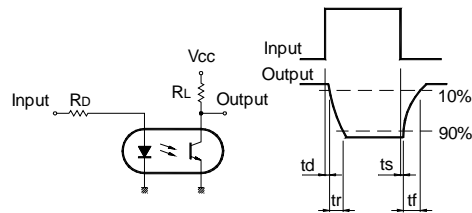

Fig.11 Frequency Response



Test Circuit for Response Time



Test Circuit for Frequency Response

