

AMMP-6442

37- 40 GHz, 1W Linear Power Amplifier
in SMT Package

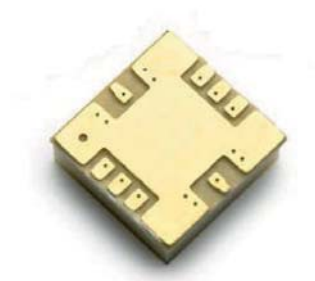

Data Sheet



Description

The AMMP-6442 MMIC is a 1W linear power amplifier in a surface mount package designed for use in transmitters that operate at frequencies between 37GHz and 40GHz. In the operational band, it provides 30dBm of output power (P-1dB) and 23dB of small-signal gain. This PA is also designed for high linear applications with typical performance of 35dBm OIP3 at 18dBm SCL output.

Pin Connections (Top View)

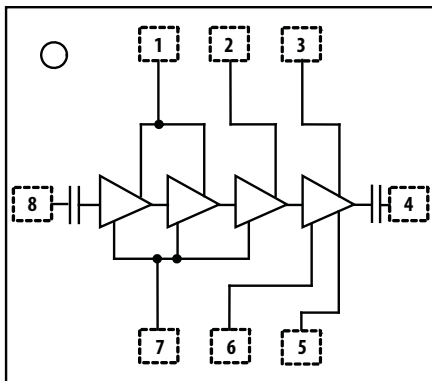

Pin	Function
1	Vd1
2	Vd2
3	Vd3
4	RF OUT
5	Vd3
6	Vg2
7	Vg1
8	RF IN

Features

- 5x5mm SMT package
- 1 watt output power
- 50 Ω match on input and output
- ESD protection (50V MM, and 250V HBM)

Typical Performance (Vd = 5V, Idsq = 0.7A)

- Frequency range 37 to 40 GHz
- Small signal Gain of 23dB (Typ.)
- Output power @P-1 of 30dBm (Typ.)
- Input and Output return losses -8dB
- OIP3 of 35dBm @Po=18dBm (scl)

Applications

- Point-to-Point Radio Systems
- mmW Communications

Note:

1. This MMIC uses depletion mode pHEMT devices. Negative supply is used for DC gate biasing.



Attention: Observe Precautions for handling electrostatic sensitive devices.

ESD Machine Model (Class A): 50V
ESD Human Body Model (Class 1A): 250V
Refer to Avago Application Note A004R:
Electrostatic Discharge Damage and Control.

Absolute Maximum Ratings^[1,2,3, and 4]

Symbol	Parameters	Unit	Max
V _d	Positive Supply Voltage ^[2]	V	5.5
V _g	Gate Supply Voltage	V	-2 to 0
P _D	Power Dissipation ^[2,3]	W	6
P _{in}	CW Input Power ^[2]	dBm	20
T _{ch}	Operating Channel Temp. ^[4,5]	°C	+150
T _{stg}	Storage Case Temp.	°C	-65 to +155
T _{max}	Maximum Assembly Temp (30 sec max)	°C	+260

Note:

1. Operation in excess of any one of these conditions may result in permanent damage to this device.
2. Combinations of supply voltage, drain current, input power, and output power shall not exceed P_D.
3. These ratings apply to each individual FET
4. The operating channel temperature will directly affect the device MTTF. For maximum life, it is recommended that junction temperatures be maintained at the lowest possible levels.

DC Specifications/ Physical Properties^[1]

Symbol	Parameters and Test Conditions	Unit	Min	Typ	Max
I _{d(q)}	Quiescent Drain Supply Current (V _d = 5 V, V _g set for I _{d(q)} Typical)	mA		700	
V _g	Gate Supply Operating Voltage (I _{d(q)} = 700 (mA))	V	-1.3	-1	-0.7
θ _{ch-bs}	Thermal Resistance (Channel-to-Base Plate)	°C/W		12	
T _{ch}	Channel Temperature	°C		150	

Note:

1. Assume AnPb soldering to an evaluation RF module at 90.5°C base plate temperatures.

RF Specifications^[1,2,3, and 4]

T_A = 25°C, V_{dd} = 5.0 V, I_{dq} = 0.7 A, V_g = -1V, Z_o = 50 Ω

Symbol	Parameters and Test Conditions	Units	Minimum	Typical	Maximum
Freq	Operational Frequency	GHz	37		40
Gain	Small-signal Gain ^[3, 4]	dB	20	23	
P _{-1dB}	Output Power at 1dB ⁽⁴⁾ Gain Compression	dBm	28	30	
IM3	Relative third Order Inter-modulation Level Δf = 20MHz, P _o = +18dBm, SCL	dBc		36	
RL _{in}	Input Return Loss	dB		8	
RL _{out}	Output Return Loss	dB		8	
Isolation	Reverse Isolation	dB		45	

Note:

1. Small/Large -signal data measured in packaged form on a 2.4mm connector based evaluation board at T_A = 25°C.
2. This final package part performance is verified by a functional test correlated to actual performance at one or more frequencies.
3. Pre-assembly into package performance verified 100% on-wafer published specifications at Frequencies=37 and 40GHz
4. The Gain and P1dB tested at 37 and 40GHz guaranteed with measurement accuracy ± 1.5 dB for gain and ±1.6dB for P1dB.

Typical Performance (Data was obtained from a 2.4mm connector based test fixture and includes connector and board losses. Connector and board loss is approximately 0.75dB at input and output ports for an approximate total of 1.5dB.)

($T_A = 25^\circ\text{C}$, $V_{dd} = 5\text{V}$, $I_{dq} = 0.7\text{A}$, $V_g = -1\text{V}$, $Z_{in} = Z_{out} = 50\ \Omega$)

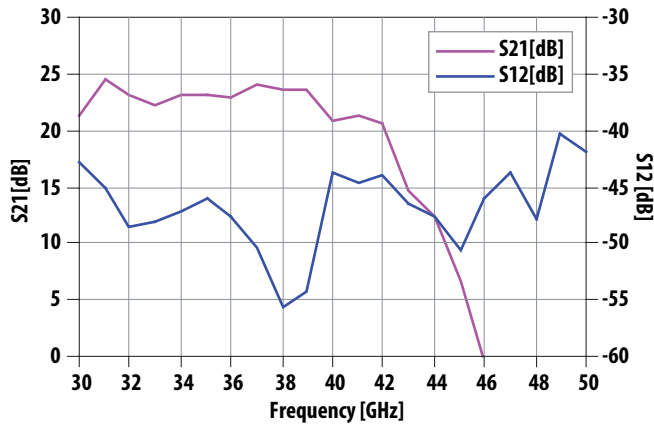

Figure 1. Typical gain and reverse isolation

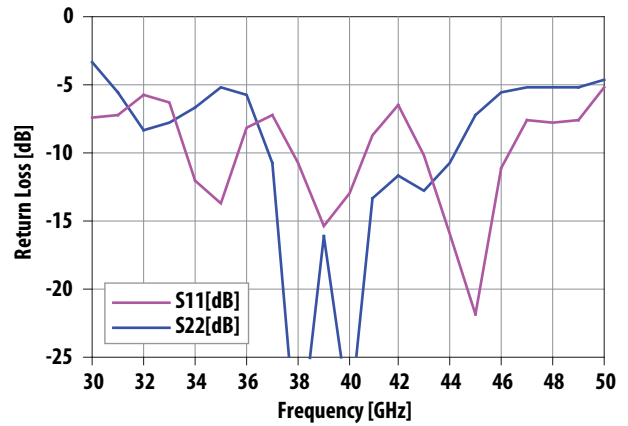

Figure 2. Typical return Loss (input and output)

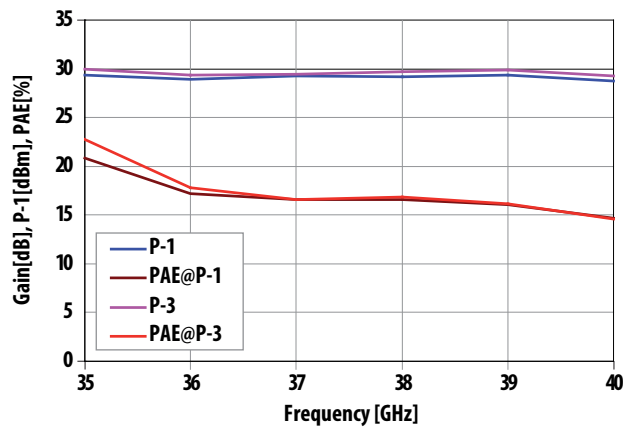

Figure 3. Typical output power (P-1 and P-3) vs. frequency

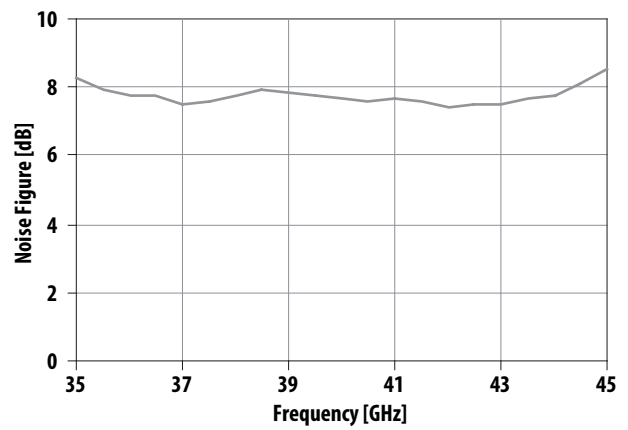

Figure 4. Typical noise figure

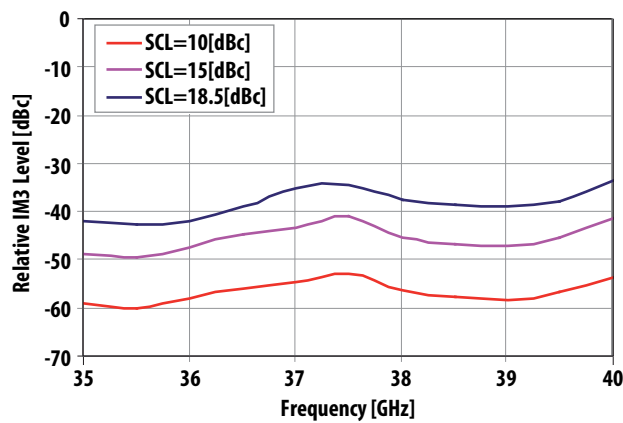

Figure 5. Typical third order inter-modulation product level vs. frequency at different single carrier output level (SCL)

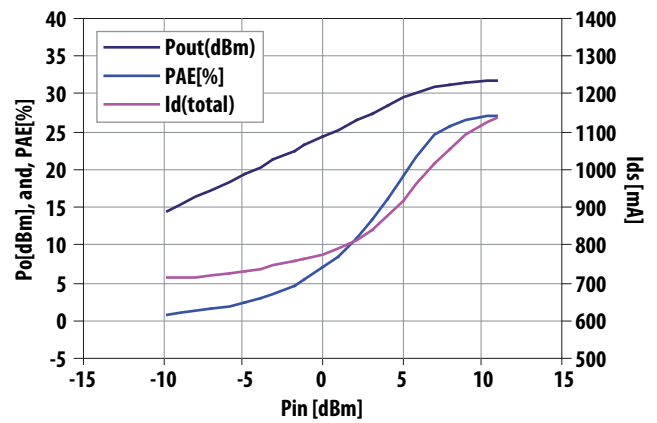

Figure 6. Typical output power, PAE, and total drain current versus Input power at 38GHz

Typical over temperature dependencies

($T_A = 25^\circ\text{C}$, $V_{dd} = 5\text{V}$, $I_{dq} = 0.7\text{A}$, $V_g = -1\text{V}$, $Z_{in} = Z_{out} = 50\ \Omega$)

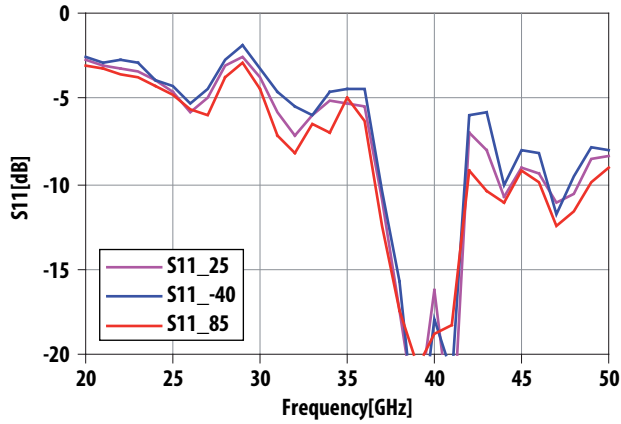

Figure 7. Typical S11 over temperature

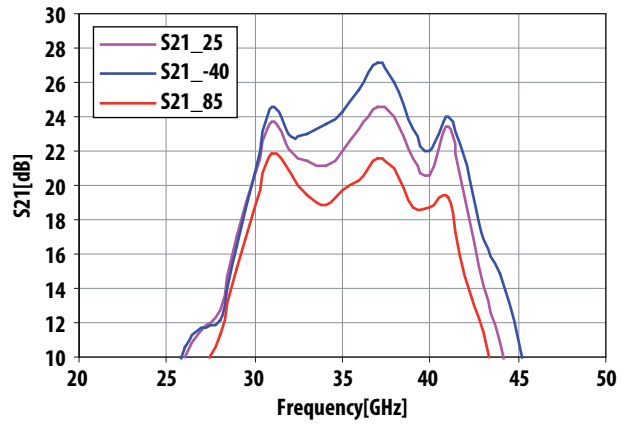

Figure 8. Typical Gain over temperature

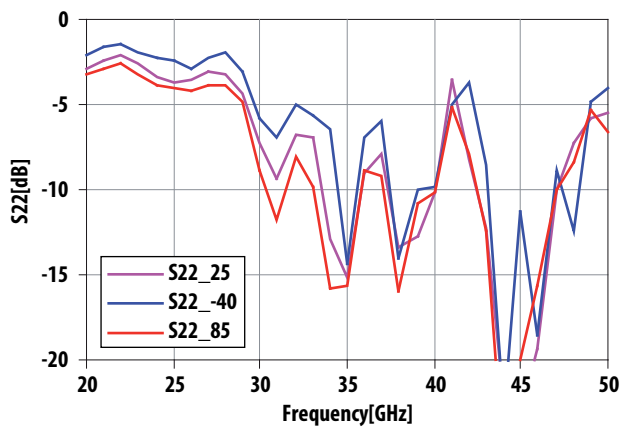

Figure 9. Typical S22 over temperature

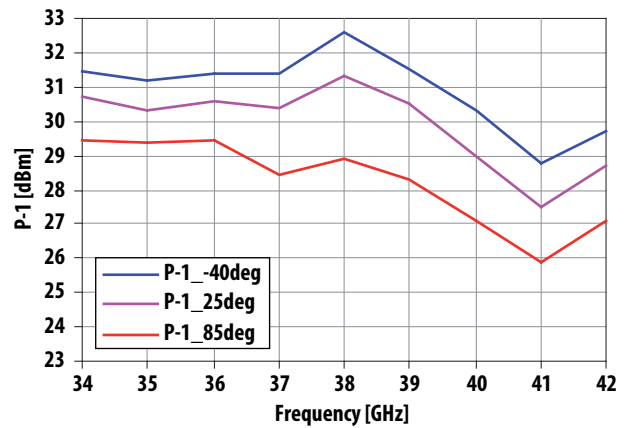

Figure 10. Typical P1 over temperature

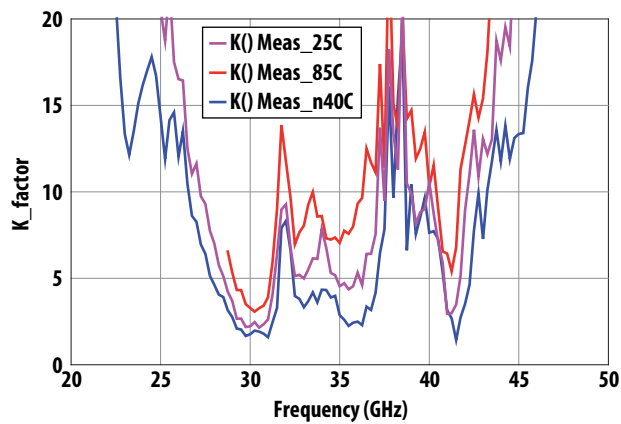

Figure 11. Typical K-factor over temperature

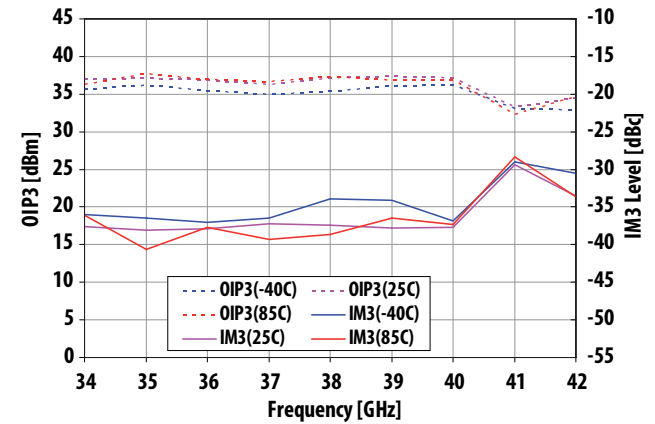

Figure 12. Typical IM3 level over temperature at $P_o=18\text{dBm}$, SCL

Typical Scattering Parameters [1], ($T_A = 25^\circ\text{C}$, $V_d = 5\text{ V}$, $I_D = 0.7\text{ A}$, $Z_{in} = Z_{out} = 50\ \Omega$)

Freq	S11 [dB]	S11 Mag.	S11 Ang.	S21 [dB]	S21 Mag.	S21 Ang.	S12 [dB]	S12 Mag.	S12 Ang.	S22 [dB]	S22 Mag.	S22 Ang.
20	-2.90	0.72	164.53	-23.81	0.06	-141.01	-48.88	3.60E-03	-57.97	-2.69	0.73	21.40
21	-3.00	0.71	86.65	-15.74	0.16	115.71	-52.28	2.43E-03	-104.05	-2.41	0.76	-70.16
22	-3.08	0.70	4.08	-7.22	0.44	0.83	-45.40	5.37E-03	152.36	-2.25	0.77	-161.69
23	-3.18	0.69	-87.20	0.27	1.03	-131.23	-46.50	4.73E-03	103.80	-2.68	0.73	112.41
24	-3.62	0.66	176.98	4.45	1.67	92.82	-48.17	3.90E-03	-13.03	-3.39	0.68	32.65
25	-4.52	0.59	84.30	7.24	2.30	-36.02	-48.90	3.59E-03	-66.94	-3.55	0.66	-45.60
26	-5.00	0.56	-8.28	9.35	2.93	-154.65	-50.90	2.85E-03	-147.71	-2.98	0.71	-125.74
27	-4.11	0.62	-104.27	11.05	3.57	81.71	-48.42	3.79E-03	176.54	-2.72	0.73	155.15
28	-3.00	0.71	168.96	13.11	4.52	-26.13	-48.48	3.77E-03	100.75	-3.20	0.69	77.20
29	-2.20	0.78	90.69	16.36	6.57	-143.75	-44.95	5.66E-03	16.82	-4.92	0.57	-11.91
30	-3.25	0.69	7.32	21.27	11.57	95.82	-42.75	7.28E-03	-67.62	-7.33	0.43	-126.78
31	-5.62	0.52	-81.47	24.48	16.76	-48.77	-45.14	5.53E-03	-173.22	-7.23	0.44	132.40
32	-8.31	0.38	151.65	23.09	14.27	172.96	-48.44	3.78E-03	113.12	-5.77	0.51	54.23
33	-7.80	0.41	55.51	22.16	12.83	59.22	-48.10	3.94E-03	83.43	-6.33	0.48	-12.99
34	-6.69	0.46	-3.34	23.03	14.18	-64.46	-47.20	4.36E-03	14.73	-12.04	0.25	-100.71
35	-5.11	0.56	-64.50	23.07	14.25	169.26	-46.03	5.00E-03	-72.16	-13.67	0.21	6.05
36	-5.77	0.51	-136.84	22.91	13.97	48.13	-47.62	4.16E-03	-147.24	-8.21	0.39	-77.65
37	-10.68	0.29	144.16	24.12	16.07	-78.82	-50.37	3.03E-03	131.49	-7.25	0.43	-146.43
38	-32.53	0.02	70.22	23.59	15.11	148.85	-55.62	1.66E-03	37.70	-10.74	0.29	121.48
39	-16.09	0.16	123.23	23.65	15.23	12.30	-54.20	1.95E-03	-76.46	-15.37	0.17	-4.18
40	-29.19	0.03	44.21	20.79	10.95	-116.29	-43.80	6.46E-03	70.75	-13.01	0.22	-123.56
41	-13.30	0.22	-59.99	21.33	11.66	112.89	-44.57	5.91E-03	-75.57	-8.63	0.37	173.01
42	-11.59	0.26	149.87	20.57	10.68	-35.23	-43.90	6.39E-03	146.83	-6.41	0.48	75.90
43	-12.74	0.23	70.60	14.55	5.34	-173.04	-46.59	4.69E-03	7.19	-10.12	0.31	4.46
44	-10.80	0.29	4.51	12.27	4.10	48.86	-47.60	4.17E-03	-74.19	-15.97	0.16	-73.99
45	-7.28	0.43	-68.05	6.64	2.15	-95.90	-50.63	2.94E-03	175.00	-21.81	0.08	-64.83
46	-5.57	0.53	-149.37	-0.54	0.94	129.12	-45.96	5.04E-03	157.54	-11.06	0.28	-107.83
47	-5.11	0.56	128.69	-7.71	0.41	4.98	-43.66	6.56E-03	42.47	-7.63	0.42	164.84
48	-5.10	0.56	40.23	-14.75	0.18	-116.43	-47.75	4.10E-03	-27.21	-7.78	0.41	65.52
49	-5.16	0.55	-55.86	-21.51	0.08	127.74	-40.36	9.59E-03	-151.21	-7.59	0.42	-65.16
50	-4.69	0.58	-154.92	-33.07	0.02	27.73	-41.94	8.00E-03	170.09	-5.13	0.55	-177.64

Note:

1. Data obtained from 2.4-mm connector based modules, and this data is including connector loss, and board loss. The measurement reference plane is at the RF connectors.

Application and Usage

Recommended quiescent DC bias condition for optimum power and linearity performances is $V_d=5$ volts with V_g (-1V) set for $I_d=700$ mA. Minor improvements in performance are possible depending on the application. The drain bias voltage range is 3 to 5V. A single DC gate supply connected to V_g will bias all gain stages. Muting can be accomplished by setting V_g to the pinch-off voltage V_p (-2V).

A typical DC bias configuration is shown in Figure 13. V_{d3} may be biased from either side (Pin 3 or Pin 5). The RF input and output ports are DC decoupled internally. No ground wires are needed since ground connections are made with plated through-holes to the backside of the device.

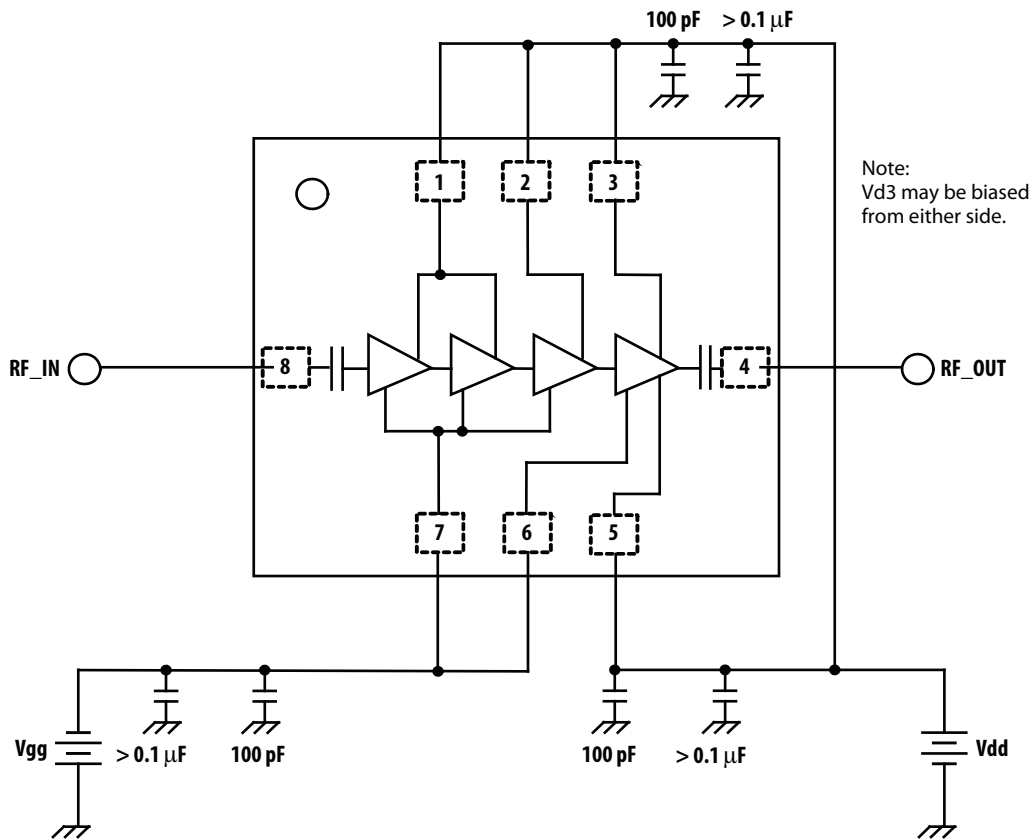

Figure 13. Schematic and recommended assemble example

Note: No RF performance degradation is seen due to ESD up to 250V HBM and 60V MM. The DC characteristics in general show increased leakage at lower ESD discharge voltages. The user is reminded that this device is ESD sensitive and needs to be handled with all necessary ESD protocols.

Recommended SMT Attachment for 5x5 Package

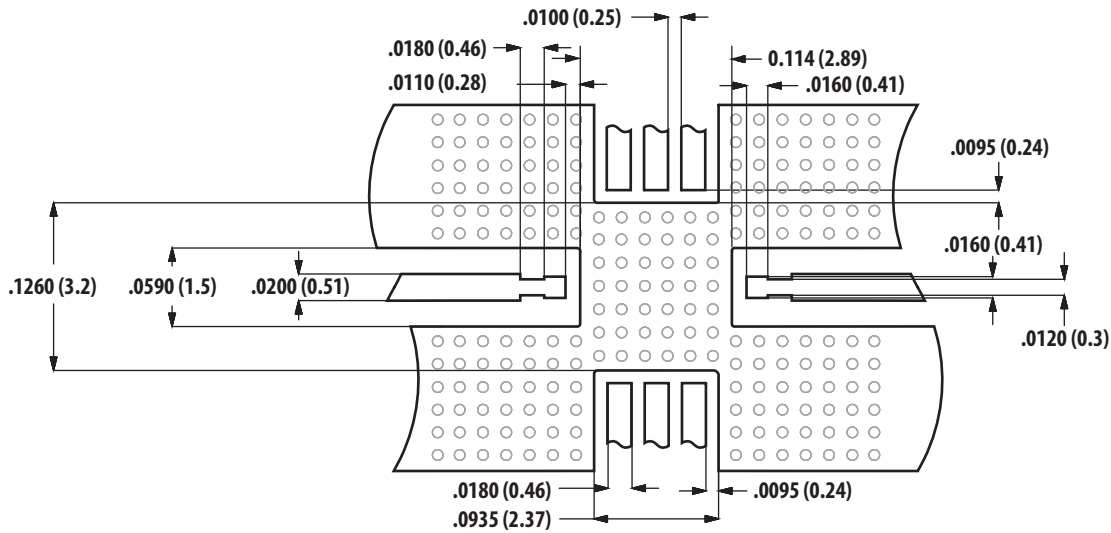

Figure 14a. Suggested PCB Land Pattern and Stencil Layout

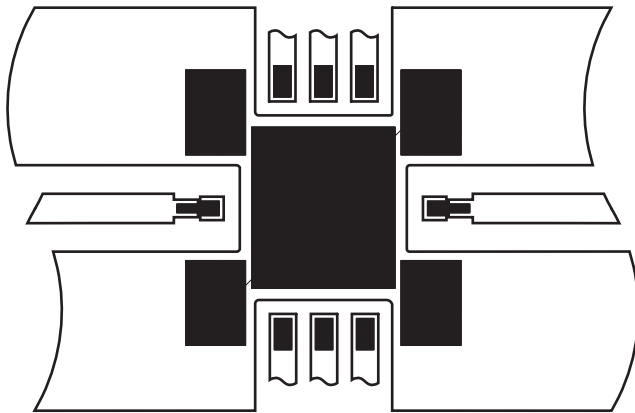

Figure 14b. PCB Land Pattern and Stencil Layouts

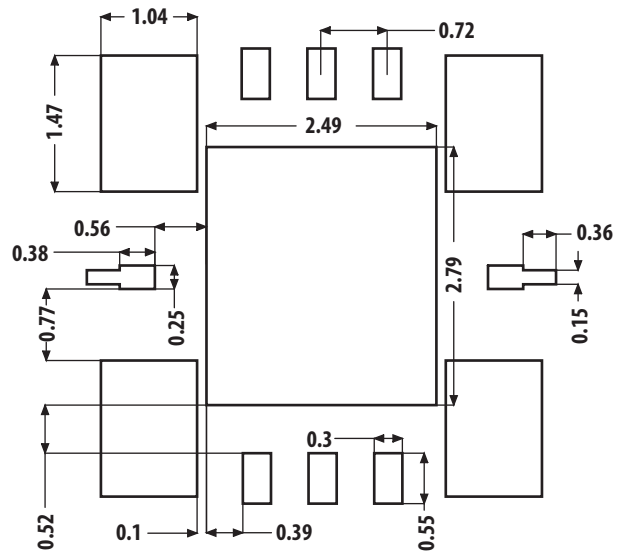

Figure 14c. Stencil Outline Drawing(mm)

The AMMP Packaged Devices are compatible with high volume surface mount PCB assembly processes. The PCB material and mounting pattern, as defined in the data sheet, optimizes RF performance and is strongly recommended. An electronic drawing of the land pattern is available upon request from Avago Sales & Application Engineering.

Manual Assembly

- Follow ESD precautions while handling packages.
- Handling should be along the edges with tweezers.
- Recommended attachment is conductive solder paste. Please see recommended solder reflow profile. Neither Conductive epoxy or hand soldering is recommended.
- Apply solder paste using a stencil printer or dot placement. The volume of solder paste will be dependent on PCB and component layout and should be controlled to ensure consistent mechanical and electrical performance.
- Follow solder paste and vendor's recommendations when developing a solder reflow profile. A standard profile will have a steady ramp up from room temperature to the pre-heat temp. to avoid damage due to thermal shock.
- Packages have been qualified to withstand a peak temperature of 260°C for 20 seconds. Verify that the profile will not expose device beyond these limits.

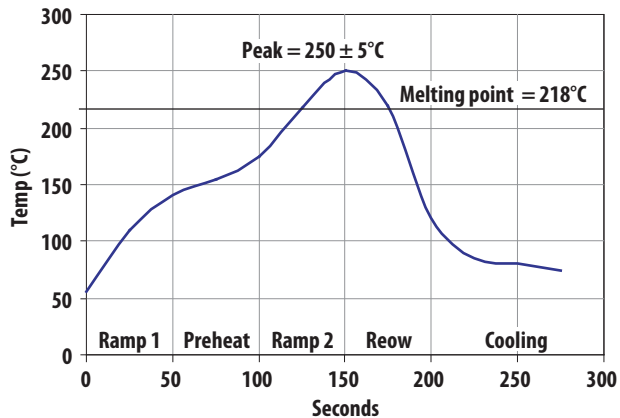

Figure 15. Suggested Lead-Free Reflow Profile for SnAgCu Solder Paste

A properly designed solder screen or stencil is required to ensure optimum amount of solder paste is deposited onto the PCB pads. The recommended stencil layout is shown in Figure 14b. The stencil has a solder paste deposition opening approximately 70% to 90% of the PCB pad. Reducing stencil opening can potentially generate more voids underneath. On the other hand, stencil openings larger than 100% will lead to excessive solder paste smear or bridging across the I/O pads. Considering the fact that solder paste thickness will directly affect the quality of the solder joint, a good choice is to use a laser cut stencil composed of 0.127mm (5 mils) thick stainless steel which is capable of producing the required fine stencil outline.

The most commonly used solder reflow method is accomplished in a belt furnace using convection heat transfer. The suggested reflow profile for automated reflow processes is shown in Figure 15. This profile is designed to ensure reliable finished joints. However, the profile indicated in Figure 1 will vary among different solder pastes from different manufacturers and is shown here for reference only.

AMMP-64xx Part Number Ordering Information

Part Number	Devices Per Container	Container
AMMP-64xx-BLK	10	Antistatic bag
AMMP-64xx-TR1	100	7" Reel
AMMP-64xx-TR2	500	7" Reel

Package, Tape & Reel, and Ordering Information

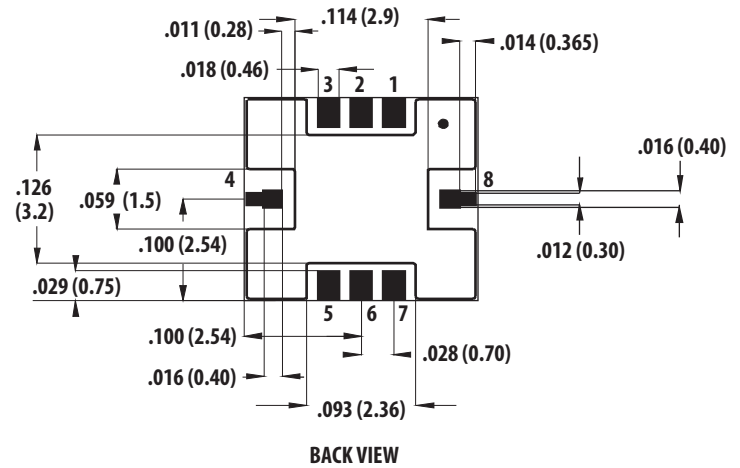
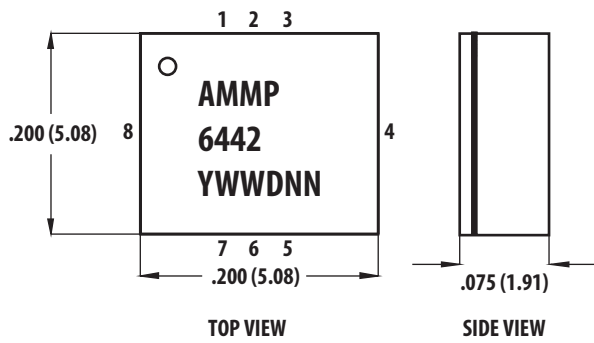

Dimensional Tolerances: 0.002" (0.05 mm)

Notes:

1. Dimensions are in inches (millimeters).
2. All grounds must be soldered to PCB RF.
3. Material is Rogers RO4350, 0.010" thick.
4. YWWDNN is manufacturing year, workweek, day and lot number

Carrier Tape and Pocket Dimensions

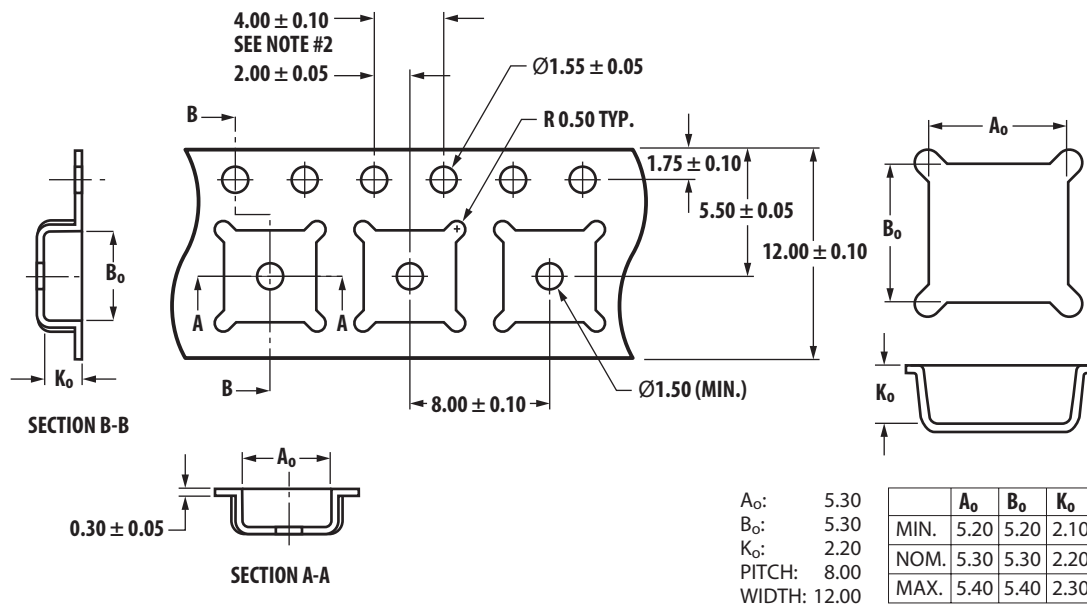

Notes:

1. A₀ and B₀ measured at 0.3 mm above base of pocket.
2. 10 pitches cumulative tolerance is ± 0.2 mm.

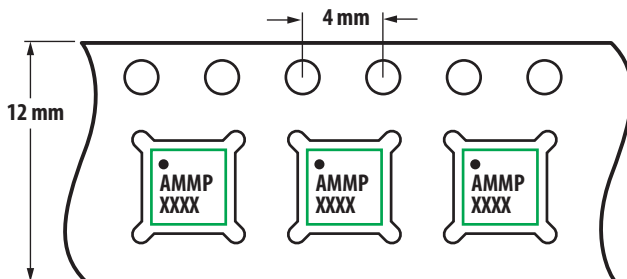

For product information and a complete list of distributors, please go to our web site: www.avagotech.com

Avago, Avago Technologies, and the A logo are trademarks of Avago Technologies in the United States and other countries. Data subject to change. Copyright © 2005-2010 Avago Technologies. All rights reserved. AV02-2399EN - August 19, 2010

AVAGO
TECHNOLOGIES