

AFCT-5710Z and AFCT-5715Z

Families of Single-Mode Small Form Factor Pluggable (SFP)
Optical Transceivers with Optional DMI for Gigabit Ethernet (1.25 GBd)



Data Sheet

Part Number Options

The AFCT-571xZ SFP family consists of the following products:

Part Number	DMI	Temperature	Latch Design
AFCT-5710LZ	No	Extended	Standard
AFCT-5710PZ	No	Extended	Bail
AFCT-5710ALZ	No	Industrial	Standard
AFCT-5710APZ	No	Industrial	Bail
AFCT-5715LZ	Yes	Extended	Standard
AFCT-5715PZ	Yes	Extended	Bail
AFCT-5715ALZ	Yes	Industrial	Standard
AFCT-5715APZ	Yes	Industrial	Bail

* Extended Temperature Range is -10 to 85 degrees C
Industrial Temperature Range is -40 to 85 degrees C

Description

The AFCT-571xZ family of Small Form Factor Pluggable (SFP) LC optical transceivers offers a wide range of design options, including optional DMI features (further described later), two temperature ranges (extended or industrial), and choice of standard or bail delatch. The AFCT-5715Z family targets applications requiring DMI, while the AFCT-5710Z family is streamlined for those applications where DMI is not needed. Throughout this datasheet, AFCT-571xZ will refer to the entire product family encompassing this full range of product options.

Related Products

- AFBR-5705Z SFP family: 1.25GBd Ethernet (1000BASE-SX) & 1.0625GBd Fiber Channel with DMI
- AFBR-5701Z SFP family: 1.25GBd Ethernet (1000BASE-SX) & 1.0625GBd Fiber Channel without DMI
- AFCT-5715Z SFP family: 1.25GBd Ethernet (1000BASE-LX) with DMI
- AFCT-5710Z SFP family: 1.25GBd Ethernet (1000BASE-LX) without DMI

Features

- ROHS-6 Compliant
- Optional Digital Diagnostic Monitoring available
 - AFCT-5710Z family: without DMI
 - AFCT-5715Z family: with DMI
- Per SFF-8472, diagnostic features on AFCT-5715Z family enable Diagnostic Monitoring Interface for optical transceivers with real-time monitoring of:
 - Transmitted optical power
 - Received optical power
 - Laser bias current
 - Temperature
 - Supply voltage
- Compliant to IEEE 802.3Z Gigabit Ethernet (1.25 GBd) 1000BASE-LX & Small Form Factor Pluggable (SFP) Multi-Source Agreement (MSA)
- Manufactured in an ISO 9001 compliant facility
- Hot-pluggable
- Temperature options (Extended) -10°C to +85°C (Industrial) -40°C to +85°C
- +3.3 V dc power supply
- 1310 nm longwave laser
- Eye safety certified:
 - US 21 CFR(J)
 - IEC 60825-1 (+All)
- LC-Duplex fiber connector compatible
- Link Lengths at 1.25 GBd:
 - 0.5 to 550 m - 50 µm MMF
 - 0.5 to 550 m - 62.5 µm MMF
 - 0.5 m to 10 km - SMF

Applications

- Ethernet Switch
- Enterprise Router
- Broadband aggregation and wireless infrastructure
- Metro Ethernet multi-service access & provisioning platforms

Overview

The AFCT-571xZ family is compliant with both IEEE 802.3Z (1000BASE-LX) and the SFP Multi-Source Agreement (MSA) specification. These transceivers are intended for premise, public and access networking applications. They are qualified in accordance with GR-468-CORE, and transmit data over single-mode (SM) fiber for a link distance of 10 km, in excess of the standard.

The AFCT-5715Z family of optical transceivers adds digital diagnostic monitoring to standard SFP functionality, enabling fault isolation, components monitoring and failure prediction capabilities.

General Features

The AFCT-571xZ is compliant to 1 GbE specifications. This includes specifications for the signal coding, optical fiber and connector types, optical and electrical transmitter characteristics, optical and electrical receiver characteristics, jitter characteristics, and compliance testing methodology for the aforementioned.

This transceiver is capable of implementing both Single Mode (SM) and Multimode (MM) optical fiber applications in that order of precedence in the event of conflicting specifications. In addition, the SM link type exceeds the 2 m to 5 km 1000BASE-LX specification by achieving compliance over 2 m to 10 km. The MM link type is expected to meet the 62.5 μm MMF specification when used with an "offset launch" fiber.

SFP MSA Compliance

The product package is compliant with the SFP MSA with the LC connector option. The SFP MSA includes specifications for mechanical packaging and performance as well as dc, ac and control signal timing and performance.

The power supply is 3.3 V dc.

The High Speed I/O (HSIO) signal interface is a Low Voltage Differential type. It is ac coupled and terminated internally to the module. The internal termination is a 100 Ohm differential load.

Installation

The AFCT-571xZ can be installed in or removed from any MSA-compliant Pluggable Small Form Factor (SFP) port regardless of whether the host equipment is operating or not. The module is simply inserted, electrical-interface first, under finger-pressure. Controlled hot-plugging is ensured by 3-stage pin sequencing at the electrical interface. This printed circuit board card-edge connector is depicted in Figure 2.

As the module is inserted, first contact is made by the housing ground shield, discharging any potentially component-damaging static electricity. Ground pins engage next and are followed by Tx and Rx power supplies. Finally, signal lines are connected. Pin functions and sequencing are listed in Table 2.

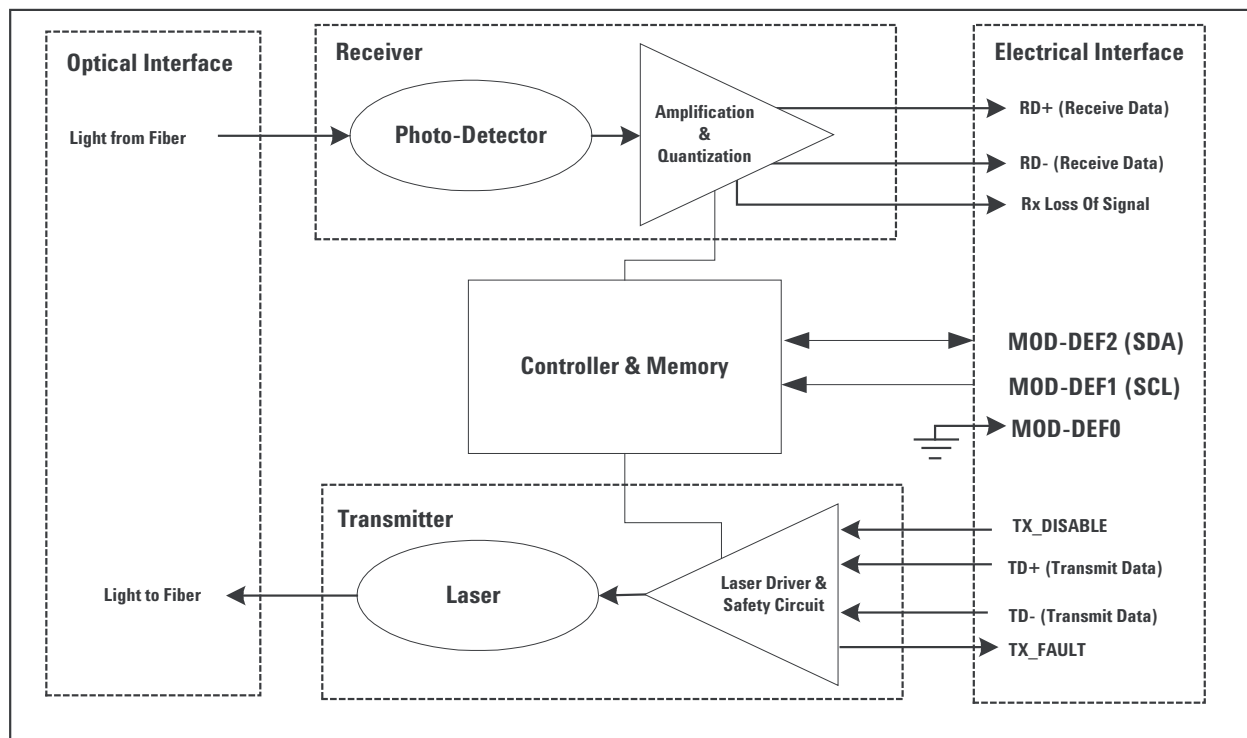

Figure 1. Transceiver Functional Diagram

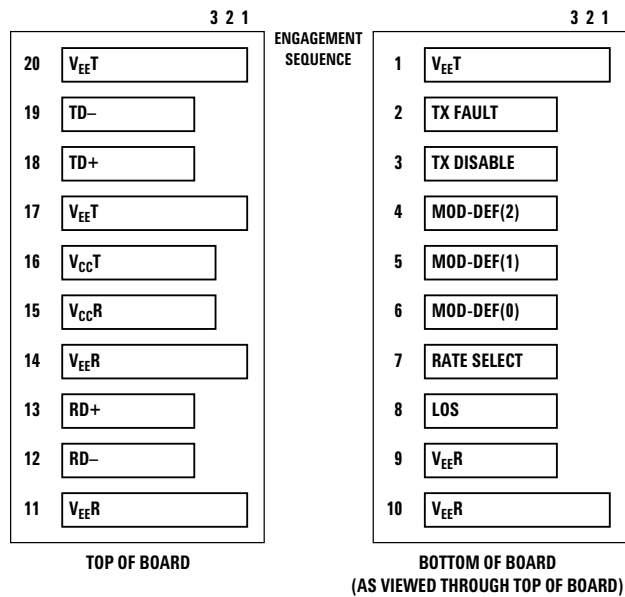

Figure 2. Pin description of the SFP electrical interface.

Transmitter Section

The transmitter section includes a 1310 nm Fabry-Perot laser and a transmitter driver circuit. The driver circuit maintains a constant optical power level provided that the data pattern is valid 8B/10B code. Connection to the transmitter is provided via a LC optical connector.

The transmitter has full IEC 60825 and CDRH Class 1 eye safety.

TX_DISABLE

The transmitter output can be disabled by asserting pin 3, TX_DISABLE. A high signal asserts this function while a low signal allows normal laser operation. In addition, via the 2-wire serial interface the transmitter output can be disabled (address A2h, byte 110, bit 6) or monitored (address A2h, byte 110, bit 7). The contents of A2h, byte 110, bit 6 are logic OR'd with hardware Tx_Disable (pin 3) to control transmitter operation. In the event of a transceiver fault, such as the activation of the eye safety circuit, toggling of the TX_DISABLE will reset the transmitter, as depicted in Figure 4.

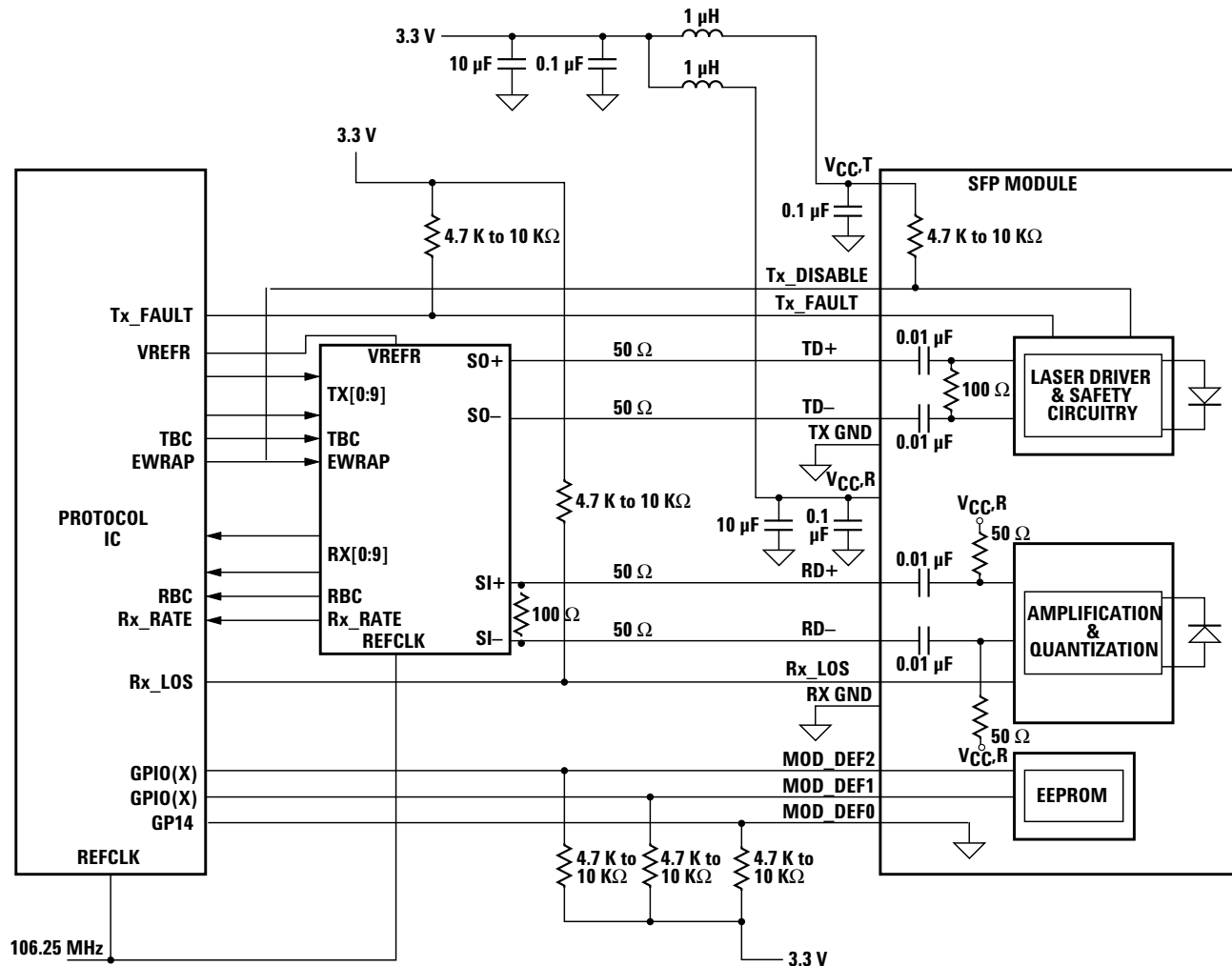

Figure 3. Typical Application Configuration

TX_FAULT

A laser fault or a low VCC condition will activate the transmitter fault signal, TX_FAULT, and disable the laser. This signal is an open collector output (pull-up required on the host board); A low signal indicates normal laser operation and a high signal indicates a fault. The TX_FAULT will be latched high when a laser fault occurs and is cleared by toggling the TX_DISABLE input or power cycling the transceiver. The TX_FAULT is not latched for Low VCC. The transmitter fault condition can also be monitored via the two-wire serial interface (address A2h, byte 110, bit 2).

Eye Safety Circuit

Under normal operating conditions, the laser power will be maintained below the eye-safety limit. If the eye safety limit is exceeded at any time, a laser fault will occur and the TX_FAULT output will be activated.

Receiver Section

The receiver section for the AFCT-571xZ contains an InGaAs/InP photo detector and a preamplifier mounted in an optical subassembly. This optical subassembly is coupled to a post amplifier/decision circuit on a circuit board. The design of the optical subassembly provides better than 12 dB Optical Return Loss (ORL).

Connection to the receiver is provided via a LC optical connector.

RX_LOS

The receiver section contains a loss of signal (RX_LOS) circuit to indicate when the optical input signal power is insufficient for Gigabit Ethernet compliance. A high signal indicates loss of modulated signal, indicating link failure such as a broken fiber or a failed transmitter. RX_LOS can be also be monitored via the two-wire serial (address A2h, byte 110, bit 1).

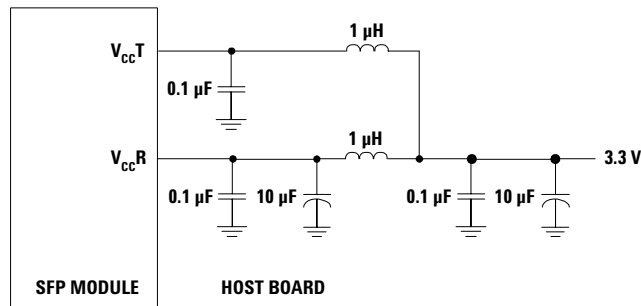

Figure 4. MSA required power supply filter

Functional Data I/O

Avago's AFCT-571xZ transceiver is designed to accept industry standard differential signals. The transceiver provides an AC-coupled, internally terminated data interface. Bias resistors and coupling capacitors have been included within the module to reduce the number of components required on the customer's board. Figure 2 illustrates the recommended interface circuit.

Digital Diagnostic Interface and Serial Identification

The AFCT-571xZ family complies with the SFF-8074i specification, which defines the module's serial identification protocol to use the 2-wire serial CMOS EEPROM protocol of the ATMEL AT24C01A or similar. Standard SFP EEPROM bytes 0-255 are addressed per SFF-8074i at memory address 0xA0 (A0h).

As an enhancement to the conventional SFP interface defined in SFF-8074i, the AFCT-5715Z is also compliant to SFF-8472 (the digital diagnostic interface for SFP). This enhancement adds digital diagnostic monitoring to standard SFP functionality, enabling failure prediction, fault isolation, and component monitoring capabilities.

Using the 2-wire serial interface, the AFCT-5715Z provides real time access to transceiver internal supply voltage and temperature, transmitter output power, laser bias current and receiver average input power, allowing a host to predict system compliance issues. These five parameters are internally calibrated, per the MSA. New digital diagnostic information is accessed per SFF-8472 using EEPROM bytes 0-255 at memory address 0xA2 (A2h).

The digital diagnostic interface also adds the ability to disable the transmitter (TX_DISABLE), monitor for Transmitter Faults (TX_FAULT) and monitor for Receiver Loss of Signal (RX_LOS).

Contents of the MSA-compliant serial ID memory are shown in Tables 10 through 14. The SFF-8074i and SFF-8472 specifications are available from the SFF Committee at <http://www.sffcommittee.org>.

Predictive Failure Identification

The diagnostic information allows the host system to identify potential link problems. Once identified, a fail-over technique can be used to isolate and replace suspect devices before system uptime is impacted.

Compliance Prediction

The real-time diagnostic parameters can be monitored to alert the system when operating limits are exceeded and compliance cannot be ensured.

Fault Isolation

The diagnostic information can allow the host to pinpoint the location of a link problem and accelerate system servicing and minimize downtime.

Component Monitoring

As part of the host system monitoring, the real time diagnostic information can be combined with system level monitoring to ensure system reliability.

Application Support

An Evaluation Kit and Reference Designs are available to assist in evaluation of the AFCT-571xZ SFPs. Please contact your local Field Sales representative for availability and ordering details.

Operating Temperature

The AFCT-571xZ family is available in either Extended (-10 to +85°C) or Industrial (-40 to +85°C) temperature ranges.

Power Supply Noise

The AFCT-571xZ can withstand an injection of PSN on the V_{CC} lines of 100 mV ac with a degradation in eye mask margin of up to 10% on the transmitter and a 1 dB sensitivity penalty on the receiver. This occurs when the product is used in conjunction with the MSA recommended power supply filter shown in Figure 3.

Regulatory Compliance

The transceiver regulatory compliance is provided in Table 1 as a figure of merit to assist the designer. The overall equipment design will determine the certification level.

Table 1. Regulatory Compliance

Feature	Test Method	Performance
Electrostatic Discharge (ESD) to the Electrical Pins	MIL-STD-883C Method 3015.4 JEDEC/EIA JESD22-A114-A	Class 2 (>2000 Volts)
Electrostatic Discharge (ESD) to the Duplex LC Receptacle	Bellcore GR1089-CORE	25 kV Air Discharge 10 Zaps at 8 kV (contact discharge) on the electrical faceplate on panel.
Electromagnetic Interference (EMI)	FCC Class B	Applications with high SFP port counts are expected to be compliant; however, margins are dependent on customer board and chassis design.
Immunity	Variation of IEC 61000-4-3	No measurable effect from a 10 V/m field swept from 80 to 1000 MHz applied to the transceiver without a chassis enclosure.
Eye Safety	US FDA CDRH AEL Class 1 EN (IEC) 60825-1, 2, EN60950 Class 1	CDRH certification # 9521220-132 TUV file 933/21201880/12
Component Recognition	Underwriter's Laboratories and Canadian Standards Association Joint Component Recognition for Information Technology Equipment Including Electrical Business Equipment	UL file # E173874
ROHS Compliance		Less than 1000ppm of: cadmium, lead, mercury, hexavalent chromium, polybrominated biphenyls, and polybrominated biphenyl ethers

Electrostatic Discharge (ESD)

There are two conditions in which immunity to ESD damage is important:

The first condition is static discharge to the transceiver during handling such as when the transceiver is inserted into the transceiver port. To protect the transceiver, it is important to use normal ESD handling precautions including the use of grounded wrist straps, work benches, and floor mats in ESD controlled areas. The ESD sensitivity of the AFCT-571xZ is compatible with typical industry production environments.

The second condition is static discharge to the exterior of the host equipment chassis after installation. To the extent that the duplex LC optical interface is exposed to the outside of the host equipment chassis, it may be subject to system-level ESD requirements. The ESD performance of the AFCT-571xZ exceeds typical industry standards. Table 1 documents ESD immunity to both of these conditions.

Electromagnetic Interference (EMI)

Most equipment designs using the AFCT-571xZ SFPs are subject to the requirements of the FCC in the United States, CENELEC EN55022 (CISPR 22) in Europe and VCCI in Japan. The metal housing and shielded design of the transceiver minimize EMI and provide excellent EMI performance.

EMI Immunity

The AFCT-571xZ transceivers have a shielded design to provide excellent immunity to radio frequency electromagnetic fields which may be present in some operating environments.

Eye Safety

The AFCT-571xZ transceivers provide Class 1 eye safety by design. Avago Technologies has tested the transceiver design for regulatory compliance, under normal operating conditions and under a single fault condition. See Table 1.

Flammability

The AFCT-571xZ family of SFPs is compliant to UL 94V-0.

Customer Manufacturing Processes

This module is pluggable and is not designed for aqueous wash, IR reflow, or wave soldering processes.

Caution

The AFCT-571xZ contains no user-serviceable parts. Tampering with or modifying the performance of the AFCT-571xZ will result in voided product warranty. It may also result in improper operation of the transceiver circuitry, and possible over-stress of the laser source. Device degradation or product failure may result. Connection of the AFCT-571xZ to a non-approved optical source, operating above the recommended absolute maximum conditions may be considered an act of modifying or manufacturing a laser product. The person(s) performing such an act is required by law to re-certify and re-identify the laser product under the provisions of U.S. 21 CF.

Table 2. Pin description

Pin	Name	Function/Description	Engagement Order(insertion)	Notes
1	VeeT	Transmitter Ground	1	
2	TX Fault	Transmitter Fault Indication	3	1
3	TX Disable	Transmitter Disable - Module disables on high or open	3	2
4	MOD-DEF2	Module Definition 2 - Two wire serial ID interface	3	3
5	MOD-DEF1	Module Definition 1 - Two wire serial ID interface	3	3
6	MOD-DEF0	Module Definition 0 - Grounded in module	3	3
7	Rate Selection	Not Connected	3	
8	LOS	Loss of Signal	3	4
9	VeeR	Receiver Ground	1	
10	VeeR	Receiver Ground	1	
11	VeeR	Receiver Ground	1	
12	RD-	Inverse Received Data Out	3	5
13	RD+	Received Data Out	3	5
14	VeeR	Receiver Ground	1	
15	VccR	Receiver Power -3.3 V \pm 5%	2	6
16	VccT	Transmitter Power -3.3 V \pm 5%	2	6
17	VeeT	Transmitter Ground	1	
18	TD+	Transmitter Data In	3	7
19	TD-	Inverse Transmitter Data In	3	7
20	VeeT	Transmitter Ground	1	

Notes:

- TX Fault is an open collector/drain output which should be pulled up externally with a 4.7K Ω – 10 K Ω resistor on the host board to a supply $<V_{ccT}+0.3$ V or $V_{ccR}+0.3$ V. When high, this output indicates a laser fault of some kind. Low indicates normal operation. In the low state, the output will be pulled to <0.8 V.
- TX disable input is used to shut down the laser output per the state table below. It is pulled up within the module with a 4.7-10 K Ω resistor.
 - Low (0 – 0.8 V): Transmitter on
 - Between (0.8 V and 2.0 V): Undefined
 - High (2.0 – 3.465 V): Transmitter Disabled
 - Open: Transmitter Disabled
- Mod-Def 0,1,2. These are the module definition pins. They should be pulled up with a 4.7-10 K Ω resistor on the host board to a supply less than $V_{ccT}+0.3$ V or $V_{ccR}+0.3$ V.
 - Mod-Def 0 is grounded by the module to indicate that the module is present
 - Mod-Def 1 is clock line of two wire serial interface for optional serial ID
 - Mod-Def 2 is data line of two wire serial interface for optional serial ID
- LOS (Loss of Signal) is an open collector/drain output which should be pulled up externally with a 4.7 K Ω – 10 K Ω resistor on the host board to a supply $<V_{ccT,R}+0.3$ V. When high, this output indicates the received optical power is below the worst case receiver sensitivity (as defined by the standard in use). Low indicates normal operation. In the low state, the output will be pulled to <0.8 V.
- RD-/+ : These are the differential receiver outputs. They are AC coupled 100 Ω differential lines which should be terminated with 100 Ω differential at the user SERDES. The AC coupling is done inside the module and is thus not required on the host board. The voltage swing on these lines must be between 370 and 2000 mV differential (185 – 1000 mV single ended) according to the MSA. Typically it will be 1500mV differential.
- VccR and VccT are the receiver and transmitter power supplies. They are defined as 3.135 – 3.465 V at the SFP connector pin. The in-rush current will typically be no more than 30 mA above steady state supply current after 500 nanoseconds.
- TD-/+ : These are the differential transmitter inputs. They are AC coupled differential lines with 100 Ω differential termination inside the module. The AC coupling is done inside the module and is thus not required on the host board. The inputs will accept differential swings of 500 – 2400 mV (250 – 1200 mV single ended). However, the applicable recommended differential voltage swing is found in Table 5.

Table 3. Absolute Maximum Ratings

Absolute maximum ratings are those values beyond which functional performance is not intended, device reliability is not implied, and damage to the device may occur.

Parameter	Symbol	Minimum	Maximum	Unit	Notes
Storage Temperature (non-operating)	T_s	-40	+100	° C	
Relative Humidity	RH	5	95	%	
Case Temperature	T_c	-40	85	° C	
Supply Voltage	V_{CC}	-0.5	3.8	V	1
Control Input Voltage	V_I	-0.5	$V_{CC}+0.5$	V	

Table 4. Recommended Operating Conditions

Typical operating conditions are those values for which functional performance and device reliability is implied.

Parameter	Symbol	Minimum	Typical	Maximum	Unit	Notes
Case Operating Temperature						
AFCT-5710LZ/PZ & AFCT-5715LZ/PZ	T_c	-10		+85	° C	
AFCT-5710ALZ/APZ & AFCT-5715ALZ/APZ	T_c	-40		+85	° C	
Supply Voltage	V_{CC}	3.14	3.3	3.47	V	

Table 5. Transceiver Electrical Characteristics

Parameter	Symbol	Minimum	Typical	Maximum	Unit	Notes
Module supply current	I_{CC}		200	240	mA	2
Power Dissipation	P_{DISS}		660	830	mW	2
AC Electrical Characteristics						
Power Supply Noise Rejection (peak - peak)	PSNR		100		mV	3
Inrush Current				30	mA	
DC Electrical Characteristics						
Sense Outputs:						
Transmit Fault (TX_FAULT)	V_{OH}	2.0		$V_{CC}T, R+0.3$	V	4
Loss of Signal (LOS) MOD-DEF2	V_{OL}			0.8	V	
Control Inputs:						
Transmitter Disable (TX_DISABLE) MOD-DEF1, 2	V_{IH} V_{IL}	2.0		V_{CC} 0.8	V	4,5
Data Input:						
Transmitter Differential Input Voltage (TD+/-)	V_I	500		2400	mV	6
Data Output:						
Receiver Differential Output Voltage (RD+/-)	V_O	370		1600	mV	7
Receiver Data Rise and Fall Times	T_{rf}			400	ps	
Receiver Contributed Total Jitter	TJ			0.33 267	UI ps	8

Notes:

- 1 The module supply voltages, $V_{CC}T$ and $V_{CC}R$, must not differ by more than 0.5V or damage to the device may occur.
2. Over temperature and Beginning of Life.
3. MSA filter is required on host board 10 Hz to 1 MHz. See Figure 3
4. LVTTTL, External 4.7 - 10 K Ω Pull-Up Resistor required
5. LVTTTL, Internal 4.7 - 10 K Ω Pull-Up Resistor required for TX_Disable
6. Internally ac coupled and terminated (100 Ohm differential)
7. Internally ac coupled and load termination located at the user SerDes
8. Per IEEE 802.3

Table 6. Transmitter Optical Characteristics

Parameter	Symbol	Minimum	Typical	Maximum	Unit	Notes
Average Optical Output Power	P_{OUT}	-9.5		-3	dBm	Note 1
Optical Extinction Ratio	ER	9			dB	
TX Optical Eye Mask Margin	MM	0	30		%	Note 3
Center Wavelength	λ_c	1270		1355	nm	
Spectral Width - rms	σ, rms			4	nm	
Optical Rise/Fall Time	t_r, t_f			260	ps	20-80%
Relative Intensity Noise	RIN			-120	dB/Hz	
Contributed Total Jitter (Transmitter) 1.25 Gb/s	TJ			0.284 227	UI ps	Note 2
P_{OUT} TX_DISABLE Asserted	P_{OFF}			-45	dBm	

Notes:

- Class 1 Laser Safety per FDA/CDRH
- Contributed total jitter is calculated from DJ and RJ measurements using $TJ = RJ + DJ$. Contributed RJ is calculated for 1×10^{-12} BER by multiplying the RMS jitter (measured on a single rise or fall edge) from the oscilloscope by 14. Per FC-PI (Table 9 - SM jitter output, note 1), the actual contributed RJ is allowed to increase above its limit if the actual contributed DJ decreases below its limits, as long as the component output DJ and TJ remain within their specified FC-PI maximum limits with the worst case specified component jitter input.
- Eye shall be measured with respect to the mask of the eye using filter defined in IEEE 802.3 section 38.6.5

Table 7. Receiver Optical Characteristics

Parameter	Symbol	Minimum	Typical	Maximum	Unit	Notes
Input Optical Power	P_{IN}			-3	dBm	
Receiver Sensitivity	P_{MIN}			-19	dBm	1, 2
Stressed Receiver Sensitivity (Optical Average Input Power)				-14.4	dBm	
Receiver Electrical 3 dB Upper Cutoff Frequency				1500	MHz	
Operating Center Wavelength	λ_c	1270		1355	nm	
Return Loss (minimum)		12			dB	
Loss of Signal - Assert	P_A	-30			dBm	3
Loss of Signal - De-Assert	P_D			-20	dBm	3
Loss of Signal - Hysteresis	$P_D - P_A$	0.5			dB	

Notes:

- $BER = 10^{-12}$
- An average power of -20 dBm with an Extinction Ratio of 9 dB is approximately equivalent to an OMA of 15 μW .
- These average power values are specified with an Extinction Ratio of 9 dB. The loss-of-signal circuitry responds to valid 8B/10B-encoded peak to peak input optical power, not average power.

Table 8. Transceiver Timing Characteristics

Parameter	Symbol	Minimum	Maximum	Unit	Notes
Hardware TX_DISABLE Assert Time	t _{off}		10	µs	Note 1
Hardware TX_DISABLE Negate Time	t _{on}		1	ms	Note 2
Time to initialize, including reset of TX_FAULT	t _{init}		300	ms	Note 3
Hardware TX_FAULT Assert Time	t _{fault}		100	µs	Note 4
Hardware TX_DISABLE to Reset	t _{reset}	10		µs	Note 5
Hardware RX_LOS Assert Time	t _{loss_on}		100	µs	Note 6
Hardware RX_LOS De-Assert Time	t _{loss_off}		100	µs	Note 7
Software TX_DISABLE Assert Time	t _{off_soft}		100	ms	Note 8
Software TX_DISABLE Negate Time	t _{on_soft}		100	ms	Note 9
Software Tx_FAULT Assert Time	t _{fault_soft}		100	ms	Note 10
Software Rx_LOS Assert Time	t _{loss_on_soft}		100	ms	Note 11
Software Rx_LOS De-Assert Time	t _{loss_off_soft}		100	ms	Note 12
Analog parameter data ready	t _{data}		1000	ms	Note 13
Serial bus hardware ready	t _{serial}		300	ms	Note 14
Write Cycle Time	t _{write}		10	ms	Note 15
Serial ID Clock Rate	f _{serial_clock}		400	kHz	

Notes:

1. Time from rising edge of TX_DISABLE to when the optical output falls below 10% of nominal.
2. Time from falling edge of TX_DISABLE to when the modulated optical output rises above 90% of nominal.
3. Time from power on or falling edge of Tx_Disable to when the modulated optical output rises above 90% of nominal.
4. From power on or negation of TX_FAULT using TX_DISABLE.
5. Time TX_DISABLE must be held high to reset the laser fault shutdown circuitry.
6. Time from loss of optical signal to Rx_LOS Assertion.
7. Time from valid optical signal to Rx_LOS De-Assertion.
8. Time from two-wire interface assertion of TX_DISABLE (A2h, byte 110, bit 6) to when the optical output falls below 10% of nominal. Measured from falling clock edge after stop bit of write transaction.
9. Time from two-wire interface de-assertion of TX_DISABLE (A2h, byte 110, bit 6) to when the modulated optical output rises above 90% of nominal.
10. Time from fault to two-wire interface TX_FAULT (A2h, byte 110, bit 2) asserted.
11. Time for two-wire interface assertion of Rx_LOS (A2h, byte 110, bit 1) from loss of optical signal.
12. Time for two-wire interface de-assertion of Rx_LOS (A2h, byte 110, bit 1) from presence of valid optical signal.
13. From power on to data ready bit asserted (A2h, byte 110, bit 0). Data ready indicates analog monitoring circuitry is functional.
14. Time from power on until module is ready for data transmission over the serial bus (reads or writes over A0h and A2h).
15. Time from stop bit to completion of a 1-8 byte write command.

Table 9. Transceiver Digital Diagnostic Monitor (Real Time Sense) Characteristics

Parameter	Symbol	Min	Units	Notes
Transceiver Internal Temperature Accuracy	T _{INT}	± 3.0	°C	Valid from T _C = -40 °C to +85 °C
Transceiver Internal Supply Voltage Accuracy	V _{INT}	± 0.1	V	Valid over V _{CC} = 3.3 V ± 5%
Transmitter Laser DC Bias Current Accuracy	I _{INT}	± 10	%	Percentage of nominal bias value
Transmitted Average Optical Output Power Accuracy	P _T	± 3.0	dB	Valid from 100 µW to 500µW, avg
Received Average Optical Input Power Accuracy	P _R	± 3.0	dB	Valid from 10 µW to 500µW avg

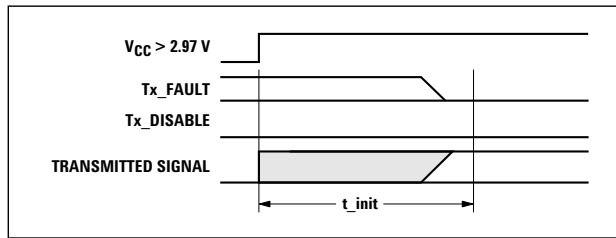

t-init: TX DISABLE NEGATED

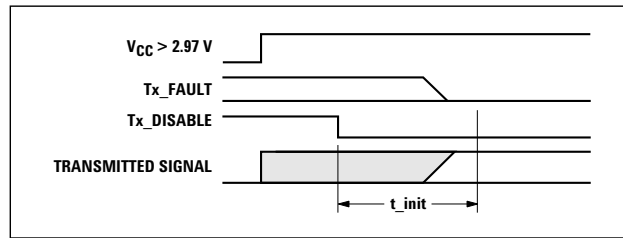

t-init: TX DISABLE ASSERTED

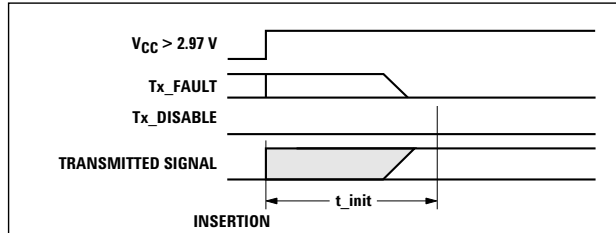

t-init: TX DISABLE NEGATED, MODULE HOT PLUGGED

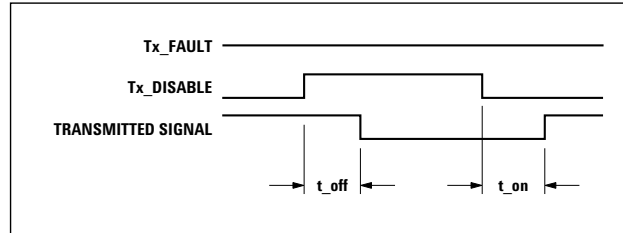

t-off & t-on: TX DISABLE ASSERTED THEN NEGATED

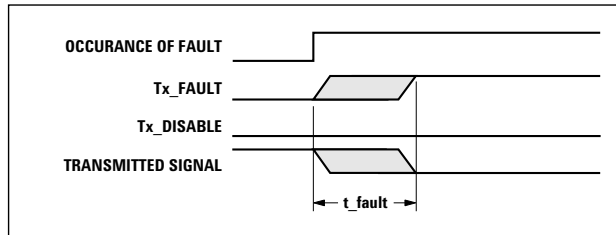

t-fault: TX FAULT ASSERTED, TX SIGNAL NOT RECOVERED

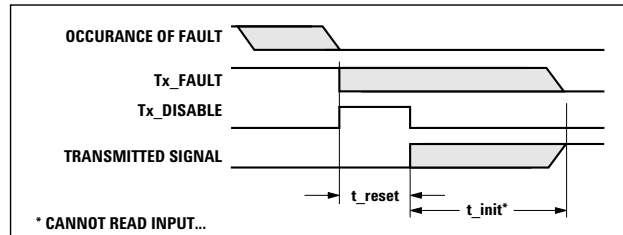

t-reset: TX DISABLE ASSERTED THEN NEGATED, TX SIGNAL RECOVERED

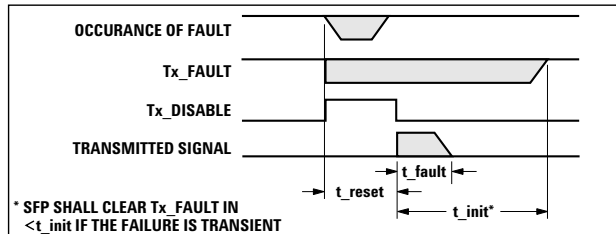

t-fault: TX DISABLE ASSERTED THEN NEGATED, TX SIGNAL NOT RECOVERED

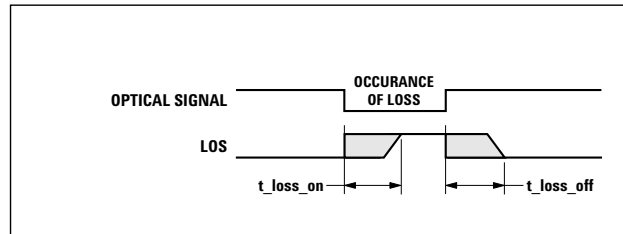

t-loss-on & t-loss-off

Figure 5. Transceiver Timing Diagrams (Module Installed Except Where Noted)

Table 10. EEPROM Serial ID Memory Contents - Page A0h

Byte # Decimal	Data Hex	Notes	Byte # Decimal	Data Hex	Notes
0	03	SFP physical device	37	00	Hex Byte of Vendor OUI (note 3)
1	04	SFP function defined by serial ID only	38	17	Hex Byte of Vendor OUI (note 3)
2	07	LC optical connector	39	6A	Hex Byte of Vendor OUI (note 3)
3	00		40	41	"A" - Vendor Part Number ASCII character
4	00		41	46	"F" - Vendor Part Number ASCII character
5	00		42	43	"C" - Vendor Part Number ASCII character
6	02	1000BASE-LX	43	54	"T" - Vendor Part Number ASCII character
7	00		44	2D	"-" - Vendor Part Number ASCII character
8	00		45	35	"5" - Vendor Part Number ASCII character
9	00		46	37	"7" - Vendor Part Number ASCII character
10	00		47	31	"1" - Vendor Part Number ASCII character
11	01	Compatible with 8B/10B encoded data	48		Note 4
12	0C	1200 MBit/sec nominal bit rate	49		Note 4
13	00		50		Note 4
14	0A		51		Note 4
15	64		52	20	" " - Vendor Part Number ASCII character
16	37	Note 1	53	20	" " - Vendor Part Number ASCII character
17	37	Note 2	54	20	" " - Vendor Part Number ASCII character
18	00		55	20	" " - Vendor Part Number ASCII character
19	00		56	20	" " - Vendor Revision Number ASCII character
20	41	"A" - Vendor Name ASCII character	57	20	" " - Vendor Revision Number ASCII character
21	56	"V" - Vendor Name ASCII character	58	20	" " - Vendor Revision Number ASCII character
22	41	"A" - Vendor Name ASCII character	59	20	" " - Vendor Revision Number ASCII character
23	47	"G" - Vendor Name ASCII character	60	05	Hex Byte of Laser Wavelength (Note 5)
24	4F	"O" - Vendor Name ASCII character	61	1E	Hex Byte of Laser Wavelength (Note 5)
25	20	" " - Vendor Name ASCII character	62	00	
26	20	" " - Vendor Name ASCII character	63		Checksum for Bytes 0-62 (Note 6)
27	20	" " - Vendor Name ASCII character	64	00	
28	20	" " - Vendor Name ASCII character	65	1A	Hardware SFP TX_DISABLE, TX_FAULT & RX_LOS
29	20	" " - Vendor Name ASCII character	66	00	
30	20	" " - Vendor Name ASCII character	67	00	
31	20	" " - Vendor Name ASCII character	68-83		Vendor Serial Number ASCII characters (Note 7)
32	20	" " - Vendor Name ASCII character	84-91		Vendor Date Code ASCII characters (Note 8)
33	20	" " - Vendor Name ASCII character	92		Note 4
34	20	" " - Vendor Name ASCII character	93		Note 4
35	20	" " - Vendor Name ASCII character	94		Note 4
36	00		95		Checksum for Bytes 64-94 (Note 6)
			96 - 255	00	

Notes:

1. Link distance with 50/125 µm cable.
2. Link distance with 62.5/125 µm.
3. The IEEE Organizationally Unique Identifier (OUI) assigned to Avago Technologies is 00-17-6A (3 bytes hex).
4. See Table 11 on following page for part number extensions and data-fields.
5. Laser wavelength is represented in 16 unsigned bits. The hex representation of 1310 (nm) is 051E.
6. Addresses 63 and 95 are checksums calculated (per SFF-8472 and SFF-8074) and stored prior to product shipment.
7. Addresses 68-83 specify the ASCII serial number and will vary on a per unit basis.
8. Addresses 84-91 specify the ASCII date code and will vary on a per date code basis.

Table 11. Part Number Extensions and Datafields

AFCT-5710ALZ			AFCT-5710APZ			AFCT-5710LZ			AFCT-5710PZ		
Address	Hex	ASCII	Address	Hex	ASCII	Address	Hex	ASCII	Address	Hex	ASCII
48	30	0	48	30	0	48	30	0	48	30	0
49	41	A	49	41	A	49	4C	L	49	50	P
50	4C	L	50	50	P	50	5A	Z	50	5A	Z
51	5A	Z	51	5A	Z	51	20		51	20	
92	0		92	0		92	0		92	0	
93	0		93	0		93	0		93	0	
94	0		94	0		94	0		94	0	

AFCT-5715ALZ			AFCT-5715APZ			AFCT-5715LZ			AFCT-5715PZ		
Address	Hex	ASCII	Address	Hex	ASCII	Address	Hex	ASCII	Address	Hex	ASCII
48	35	5	48	35	5	48	35	5	48	35	5
49	41	A	49	41	A	49	4C	L	49	50	P
50	4C	L	50	50	P	50	5A	Z	50	5A	Z
51	5A	Z	51	5A	Z	51	20		51	20	
92	68		92	68		92	68		92	68	
93	F0		93	F0		93	F0		93	F0	
94	1		94	1		94	1		94	1	

Table 12. EEPROM Serial ID Memory Contents - Address A2h (AFCT-5715Z family only)

Byte # Decimal	Notes	Byte # Decimal	Notes	Byte # Decimal	Notes
0	Temp H Alarm MSB ¹	26	Tx Pwr L Alarm MSB ⁴	104	Real Time Rx P _{AV} MSB ⁵
1	Temp H Alarm LSB ¹	27	Tx Pwr L Alarm LSB ⁴	105	Real Time Rx P _{AV} LSB ⁵
2	Temp L Alarm MSB ¹	28	Tx Pwr H Warning MSB ⁴	106	Reserved
3	Temp L Alarm LSB ¹	29	Tx Pwr H Warning LSB ⁴	107	Reserved
4	Temp H Warning MSB ¹	30	Tx Pwr L Warning MSB ⁴	108	Reserved
5	Temp H Warning LSB ¹	31	Tx Pwr L Warning LSB ⁴	109	Reserved
6	Temp L Warning MSB ¹	32	Rx Pwr H Alarm MSB ⁵	110	Status/Control - see Table 13
7	Temp L Warning LSB ¹	33	Rx Pwr H Alarm LSB ⁵	111	Reserved
8	V _{CC} H Alarm MSB ²	34	Rx Pwr L Alarm MSB ⁵	112	Flag Bits - see Table 14
9	V _{CC} H Alarm LSB ²	35	Rx Pwr L Alarm LSB ⁵	113	Flag Bit - see Table 14
10	V _{CC} L Alarm MSB ²	36	Rx Pwr H Warning MSB ⁵	114	Reserved
11	V _{CC} L Alarm LSB ²	37	Rx Pwr H Warning LSB ⁵	115	Reserved
12	V _{CC} H Warning MSB ²	38	Rx Pwr L Warning MSB ⁵	116	Flag Bits - see Table 14
13	V _{CC} H Warning LSB ²	39	Rx Pwr L Warning LSB ⁵	117	Flag Bits - see Table 14
14	V _{CC} L Warning MSB ²	40-55	Reserved	118	Reserved
15	V _{CC} L Warning LSB ²	56-94	External Calibration Constants ⁶	119	Reserved
16	Tx Bias H Alarm MSB ³	95	Checksum for Bytes 0-94 ⁷	120-122	Reserved
17	Tx Bias H Alarm LSB ³	96	Real Time Temperature MSB ¹	123	
18	Tx Bias L Alarm MSB ³	97	Real Time Temperature LSB ¹	124	
19	Tx Bias L Alarm LSB ³	98	Real Time V _{CC} MSB ²	125	
20	Tx Bias H Warning MSB ³	99	Real Time V _{CC} LSB ²	126	
21	Tx Bias H Warning LSB ³	100	Real Time Tx Bias MSB ³	127	Reserved ⁸
22	Tx Bias L Warning MSB ³	101	Real Time Tx Bias LSB ³	128-247	Customer Writable ⁹
23	Tx Bias L Warning LSB ³	102	Real Time Tx Power MSB ⁴	248-255	Vendor Specific
24	Tx Pwr H Alarm MSB ⁴	103	Real Time Tx Power LSB ⁴		
25	Tx Pwr H Alarm LSB ⁴				

Notes:

1. Temperature (Temp) is decoded as a 16 bit signed twos complement integer in increments of 1/256 °C.
2. Supply voltage (V_{CC}) is decoded as a 16 bit unsigned integer in increments of 100 µV.
3. Laser bias current (Tx Bias) is decoded as a 16 bit unsigned integer in increments of 2 µA.
4. Transmitted average optical power (Tx Pwr) is decoded as a 16 bit unsigned integer in increments of 0.1 µW.
5. Received average optical power (Rx Pwr) is decoded as a 16 bit unsigned integer in increments of 0.1 µW.
6. Bytes 55-94 are not intended for use with AFCT-5715xxxx, but have been set to default values per SFF-8472.
7. Bytes 95 is a checksum calculated (per SFF-8472) and stored prior to product shipment.
8. Byte 127 accepts a write but performs no action (reserved legacy byte).
9. Bytes 128-247 are write enabled (customer writable).

Table 13. EEPROM Serial ID Memory Contents - Address A2h, Byte 110 (AFCT-5715Z family only)

Bit #	Status/Control Name	Description
7	Tx Disable State	Digital state of SFP Tx Disable Input Pin (1 = Tx_Disable asserted)
6	Soft Tx Disable	Read/write bit for changing digital state of SFP Tx_Disable function ¹
5	Reserved	
4	Rx Rate Select State	Digital state of SFP Rate Select Input Pin (1 = full bandwidth of 155 Mbit) ²
3	Reserved	
2	Tx Fault State	Digital state of the SFP Tx Fault Output Pin (1 = Tx Fault asserted)
1	Rx LOS State	Digital state of the SFP LOS Output Pin (1 = LOS asserted)
0	Data Ready (Bar)	Indicates transceiver is powered and real time sense data is ready (0 = Ready)

Notes:

1. Bit 6 is logic OR'd with the SFP Tx_Disable input pin 3 ... either asserted will disable the SFP transmitter.
2. AFCT-5715Z does not respond to state changes on Rate Select Input Pin. It is internally hardwired to full bandwidth.

Table 14. EEPROM Serial ID Memory Contents - Address A2h, Bytes 112, 113, 116, 117 (AFCT-5715Z family only)

Byte	Bit #	Flag Bit Name	Description
112	7	Temp High Alarm	Set when transceiver internal temperature exceeds high alarm threshold.
	6	Temp Low Alarm	Set when transceiver internal temperature exceeds alarm threshold.
	5	V _{cc} High Alarm	Set when transceiver internal supply voltage exceeds high alarm threshold.
	4	V _{cc} Low Alarm	Set when transceiver internal supply voltage exceeds low alarm threshold.
	3	Tx Bias High Alarm	Set when transceiver laser bias current exceeds high alarm threshold.
	2	Tx Bias Low Alarm	Set when transceiver laser bias current exceeds low alarm threshold.
	1	Tx Power High Alarm	Set when transmitted average optical power exceeds high alarm threshold.
	0	Tx Power Low Alarm	Set when transmitted average optical power exceeds low alarm threshold.
113	7	Rx Power High Alarm	Set when received P_Avg optical power exceeds high alarm threshold.
	6	Rx Power Low Alarm	Set when received P_Avg optical power exceeds low alarm threshold.
	0-5	Reserved	
116	7	Temp High Warning	Set when transceiver internal temperature exceeds high warning threshold.
	6	Temp Low Warning	Set when transceiver internal temperature exceeds low warning threshold.
	5	V _{cc} High Warning	Set when transceiver internal supply voltage exceeds high warning threshold.
	4	V _{cc} Low Warning	Set when transceiver internal supply voltage exceeds low warning threshold.
	3	Tx Bias High Warning	Set when transceiver laser bias current exceeds high warning threshold.
	2	Tx Bias Low Warning	Set when transceiver laser bias current exceeds low warning threshold.
	1	Tx Power High Warning	Set when transmitted average optical power exceeds high warning threshold.
	0	Tx Power Low Warning	Set when transmitted average optical power exceeds low warning threshold.
117	7	Rx Power High Warning	Set when received P_Avg optical power exceeds high warning threshold.
	9	Rx Power Low Warning	Set when received P_Avg optical power exceeds low warning threshold.
	0-5	Reserved	

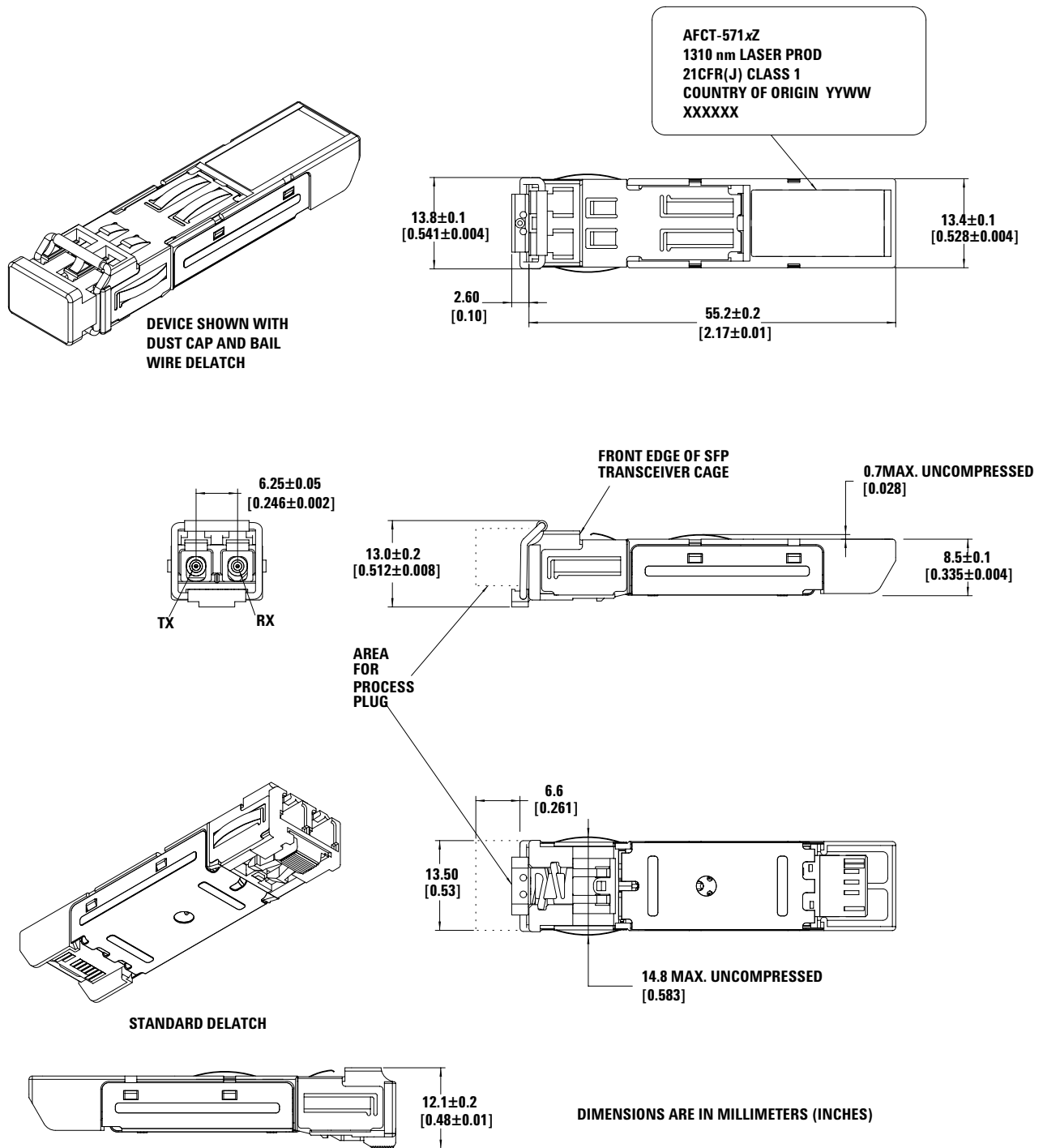

Figure 6. Drawing of SFP Transceiver

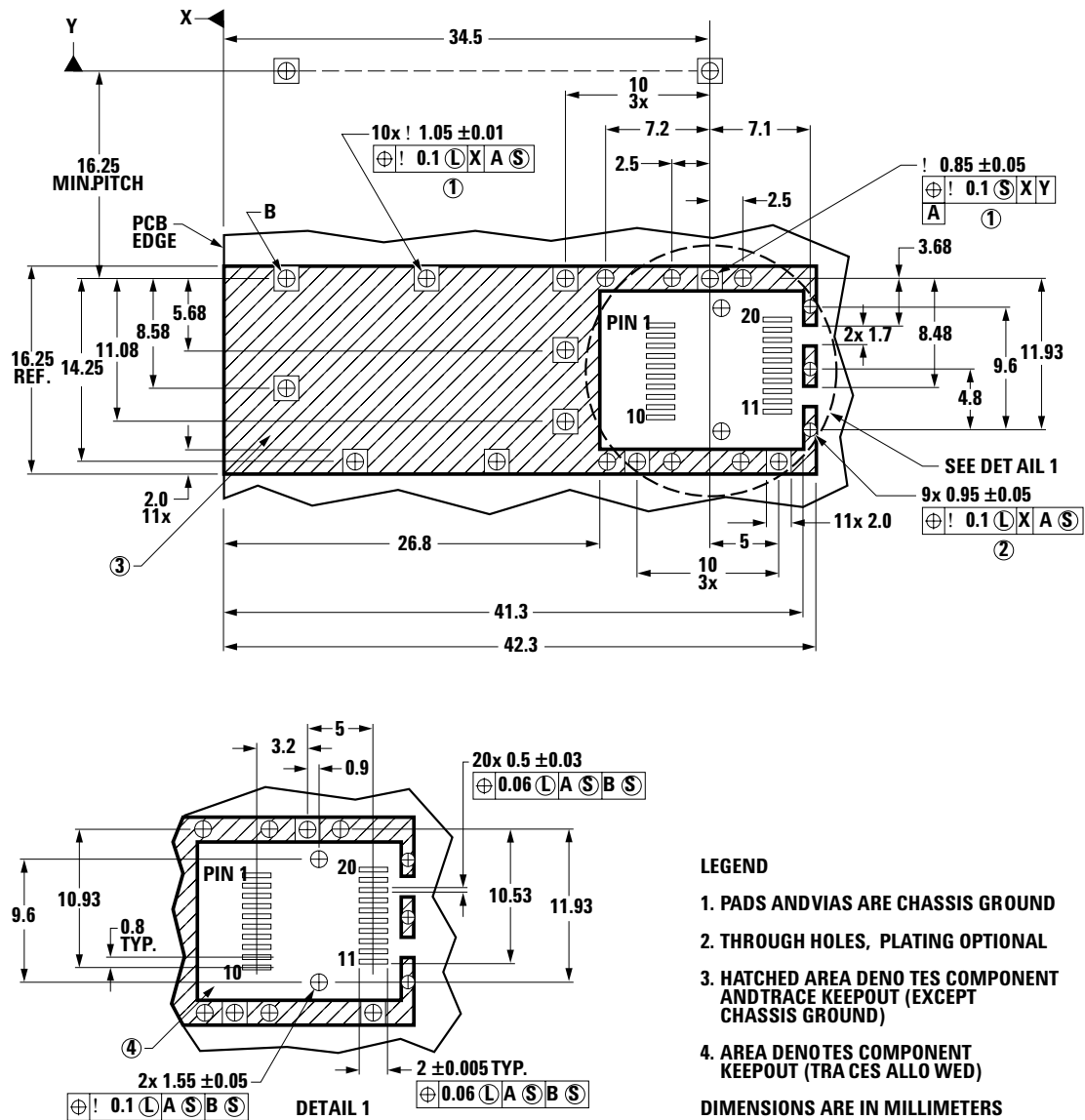
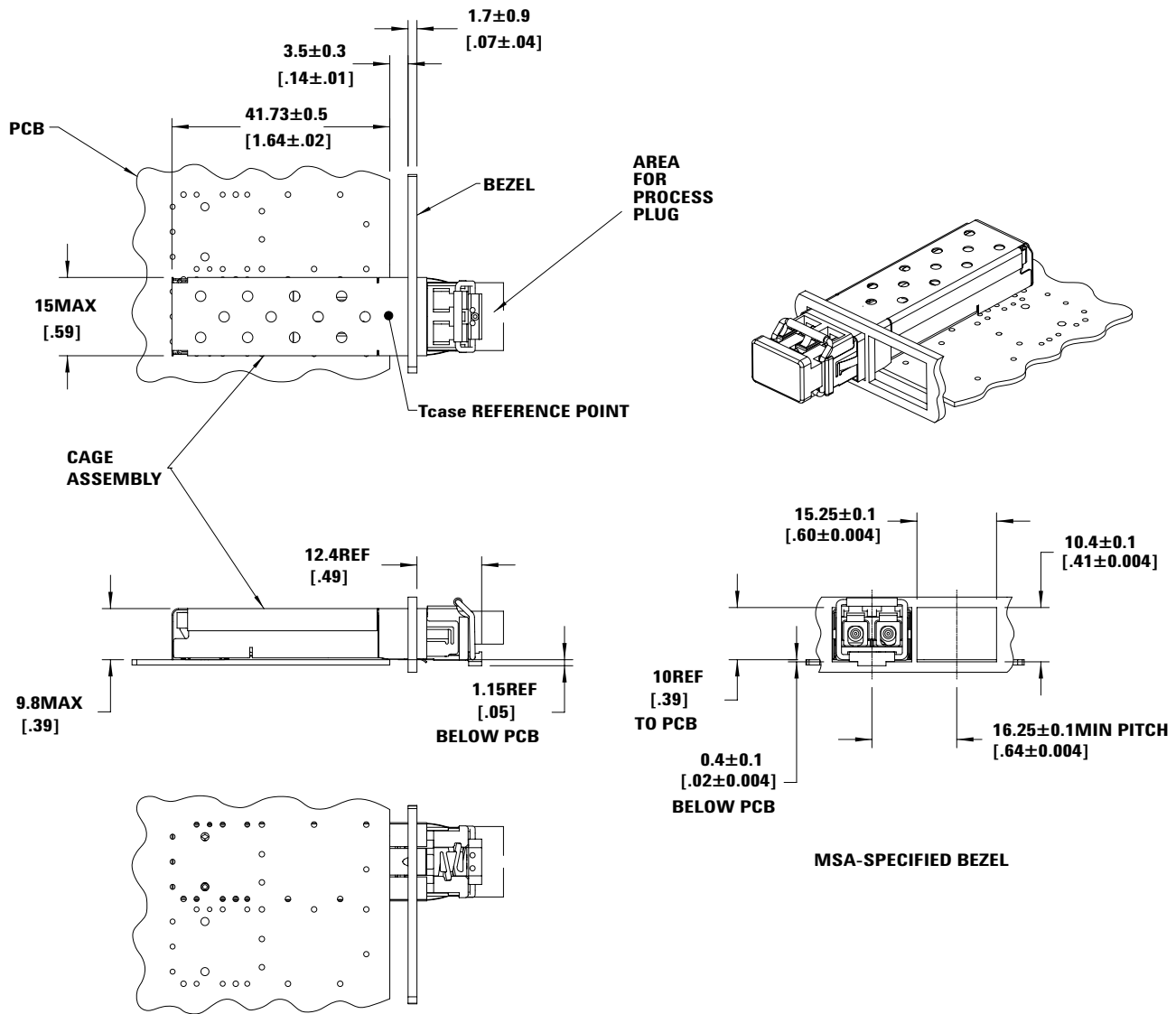

Figure 7. SFP host board mechanical layout



DIMENSIONS ARE IN MILLIMETERS [INCHES].

Figure 8. Assembly Drawing

Ordering Information

Please contact your local field sales engineer or one of Avago Technologies franchised distributors for ordering information. For technical information, please visit Avago Technologies' web-page at **www.avagotech.com** or contact one of Avago Technologies' regional Technical Response Centers.

For information related to SFF Committee documentation visit **www.sffcommittee.org**.

AFCT-5715LZ	DMI	Extended Temperature (-10°C to 85°C)	Standard Delatch
AFCT-5715PZ	DMI	Extended Temperature (-10°C to 85°C)	Bail Delatch
AFCT-5715ALZ	DMI	Industrial Temperature (-40°C to 85°C)	Standard Delatch
AFCT-5715APZ	DMI	Industrial Temperature (-40°C to 85°C)	Bail Delatch
AFCT-5710LZ	No DMI	Extended Temperature (-10°C to 85°C)	Standard Delatch
AFCT-5710PZ	No DMI	Extended Temperature (-10°C to 85°C)	Bail Delatch
AFCT-5710ALZ	No DMI	Industrial Temperature (-40°C to 85°C)	Standard Delatch
AFCT-5710APZ	No DMI	Industrial Temperature (-40°C to 85°C)	Bail Delatch

For product information and a complete list of distributors, please go to our web site: **www.avagotech.com**

Avago, Avago Technologies, and the A logo are trademarks of Avago Technologies, Pte. in the United States and other countries.
Data subject to change. Copyright © 2006 Avago Technologies Pte. All rights reserved.
AV01-0167EN - May 11, 2006

