

SANYO

No.3118

LB1617M

Monolithic Digital IC

3-Phase Brushless Motor Driver

The LB1617M is a 3-phase brushless motor driver IC ideally suited for use in movie VTR capstan motor driver, drum motor driver, and DAT motor driver applications.

Features

- 120° voltage linear type
- Less power dissipation because of speed control based on motor voltage control (suitable for use in portable sets)
- Torque ripple compensation circuit on chip
- Small capacitance of external capacitor because of soft switching method (chip capacitor)
- Thermal shutdown circuit on chip

Absolute Maximum Ratings at Ta = 25°C

			unit
Maximum Supply Voltage	V _{CC2} , V _{CC3} max	16	V
	V _{CC1} max	7	V
Supply Voltage	V _S V _S < V _{CC2}	12	V
Output Current	I _O	1.5	A
Hall Supply Current	I _H	20	mA
Allowable Power Dissipation	P _d max 30-pin MFP	1.0	W
Operating Temperature	T _{opg}	-20 to +75	°C
Storage Temperature	T _{stg}	-55 to +125	°C

Allowable Operating Conditions at Ta = 25°C

Case	V _{CC1} (Reg)	V _{CC2} (Un-Reg)	V _{CC3}
1	4 to 7V	4 to 16V	Shorted with V _{CC1}
2	Open	6 to 16V	Shorted with V _{CC2}

Electrical Characteristics at Ta = 25°C, V_{CC2} = V_{CC3} = 7.0V, V_S = 3V

			min	typ	max	unit
Supply Current 1	I _{CC1} + 3	V _{CC1} = V _{CC3} = 5V, V _{BR} = 5V		10	12	mA
Supply Current 2	I _{CC2}	V _{BR} = 5V		18	23	mA
Supply Current 3	I _S	V _{BR} = 5V	5.0	7.0		mA
Supply Standby Current	I _{CC0Q}	V _{STBY} = 0V			180	µA

Continued on next page.

Case Outline 3073A-M301C

(unit: mm)

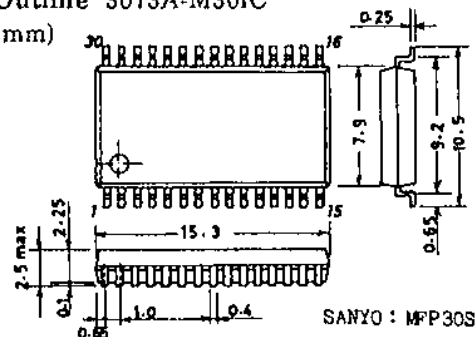

The application circuit diagrams and circuit constants herein are included as an example and provide no guarantee for designing equipment to be mass-produced. The information herein is believed to be accurate and reliable. However, no responsibility is assumed by SANYO for its use, nor for any infringements of patents or other rights of third parties which may result from its use.

Specifications and information herein are subject to change without notice.

SANYO Electric Co., Ltd. Semiconductor Overseas Marketing Div.
 Natsume Bldg., 18-6, 2-chome, Yushima, Bunkyo-ku, TOKYO 113 JAPAN

N159TA, TS - No.3118-1/6

Continued from preceding page.

			min	typ	max	unit
Output Saturation Voltage	$V_{O(sat)}$	$I_{OUT}=1.0A$ sink + source			2.3	V
Output Transistor	$V_{O(sus)}$	$I_{OUT}=20mA$	16			V
Breakdown Voltage						
Output Standby Voltage	V_{OQ}	$V_{BR}=5V$	1.43	1.63	1.63	V
Hall Amp Input Offset Voltage	$V_{HOFFSET}$		-5		+5	mV
Hall Amp Common-Mode	V_{HCOM}		1.4		2.8	V
Input Voltage Range						
Hall Input-Output Voltage Gain	G_{VHO}	Under specified circuit conditions	33	36	39	dB
Brake Pin 'H'-Level Voltage			2.0			V
Brake Pin 'L'-Level Voltage					0.8	V
Brake Pin Input Current					100	μA
Brake Pin Leak Current					-30	μA
FRC Pin 'H'-Level Voltage			2.8			V
FRC Pin 'L'-Level Voltage					1.2	V
FRC Pin Input Current					100	μA
FRC Pin Leak Current					-30	μA
Hall Supply Voltage	V_{H}	$I_H=10mA, V_{H(+)} - V_{H(-)}$	0.8	1.0	1.5	V
Upper Residual Voltage	V_{XH}	$I_{OUT}=100mA, V_{CC2}=6V, V_S=2V$	0.33		0.5	V
Lower Residual Voltage	V_{XL}	$I_{OUT}=100mA, V_{CC2}=6V, V_S=2V$	0.41		0.5	V
Residual Voltage Inflection Point				2.0		V
Overlap Amount		$V_{CC2}=6V, V_S=3V$	60	70	80	%
Operating Temperature of Thermal Shutdown Circuit			150	180	210	$^{\circ}C$
Hysteresis of Thermal Shutdown Circuit				15		$^{\circ}C$
Standby Operating Voltage					0.1	V
Standby Bias Current		Pin GND			10	μA

Design Notes

It should be noted that dielectric breakdown is liable to occur between pin 10 and other pins.

Pin Assignment

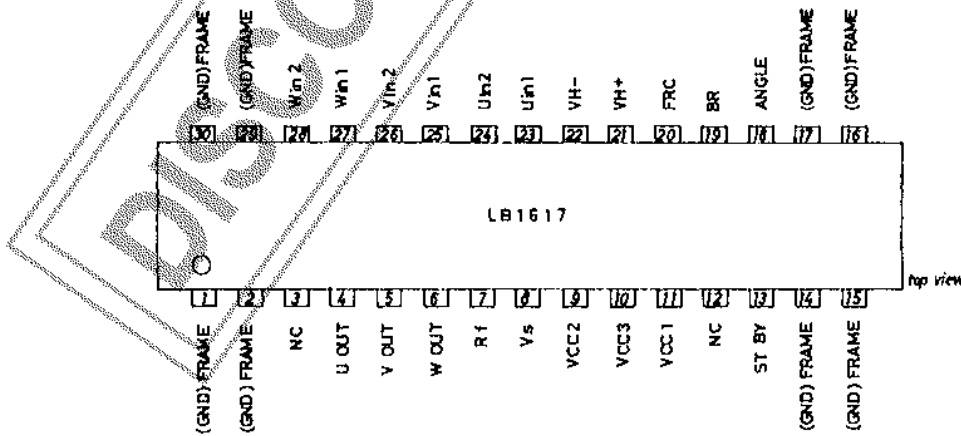

Truth Table

	Source	Sink	Input			Forward/Reverse Control
			U	V	W	
1	W phase → V phase		H	H	L	L
	V phase → W phase		H	H	L	H
2	W phase → U phase		H	L	L	L
	U phase → W phase		H	L	L	H
3	V phase → W phase		L	L	H	L
	W phase → V phase		L	L	H	H
4	U phase → V phase		L	H	L	L
	V phase → U phase		L	H	L	H
5	V phase → U phase		H	L	H	L
	U phase → V phase		H	L	H	H
6	U phase → W phase		L	H	H	L
	W phase → U phase		L	H	H	H

Input: "H": Input 1 of each phase is at a potential which is higher by more than 0.2V relative to input 2.
 "L": Input 1 of each phase is at a potential which is lower by more than 0.2V relative to input 2.
 Forward/reverse control: "H": 2.8 to V_{CC2}
 "L": 0 to 1.2V

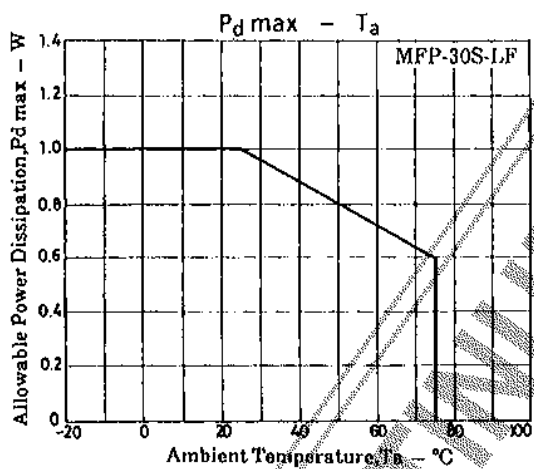

Equivalent Circuit Block Diagram

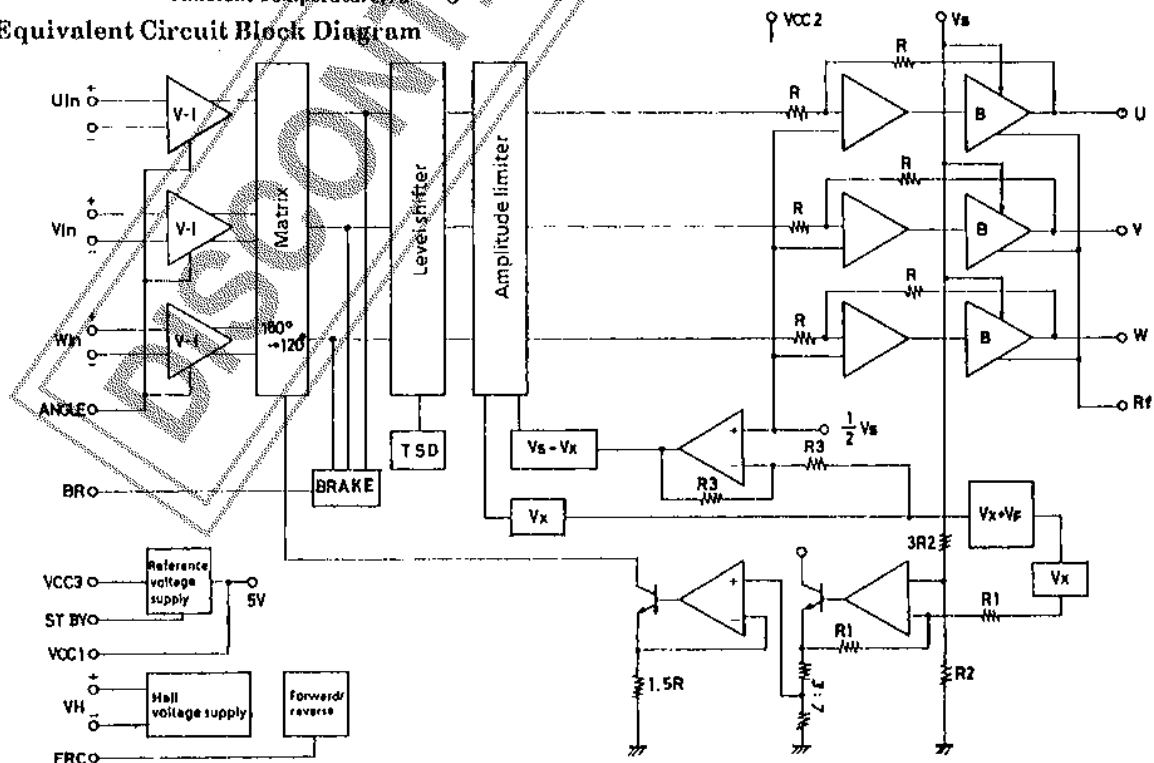

Pin Description

Pin No.	Pin Symbol	Pin Voltage	Equivalent Circuit	Pin Function
1,2 14,15 16,17 29,30	FRAME (GND)			GND for other than output
4 5 6	U_{out} V_{out} W_{out}			Output pins
7	R_f			GND for output transistor
8	V_s	$< V_{CC2}$		Power supply pin for fixing the output amplitude. Must be lower than V_{CC2} voltage.
9	V_{CC2}			Power supply pin for power amp circuit other than motor driver transistor. Power supply pin for supplying voltage to other than the control section whose supply voltage is V_{CC1} , V_{CC3} .
10	V_{CC3}			Power supply pin for hall bias power supply, 1.2V reference voltage, V_{CC1} internal power supply.
11	V_{CC1}			Power supply pin for supplying voltage to the hall amp, forward/reverse control, thermal shutdown circuit. When this pin is left open, a voltage of approximately 5V is supplied internally.
13	ST.BY	L: 0.1V max H: 2.0V min		When this pin is grounded, all the circuitry stops operating. In this case, the supply current is approximately 100 μ A. In the normal operation mode, this pin is left open or made to be at a potential of more than 2V.
18	ANGLE			The hall input-output gain (slope of motor waveform) can be changed by changing the resistance connected across this pin and GND. $\approx 10k\Omega$
19	BR	H: 2.0V min L: 0.8V max (When $V_{CC1} = 5V$)		Pin for stopping the motor L level : Motor drive (Less than 0.8V : When $V_{CC1} = 5V$) H level : Motor stop (More than 2.0V : When $V_{CC1} = 5V$)

Continued on next page.

Continued from preceding page.

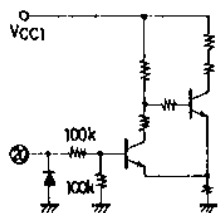
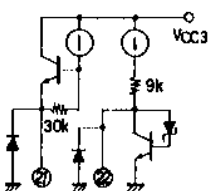
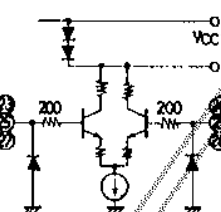
Pin No.	Pin Symbol	Pin Voltage	Equivalent Circuit	Pin Function
20	FRC	H: 1.2V min L: 2.8V max (When $V_{CC1} = 5V$)		Pin for forward/reverse control of motor L level: Forward (Less than 1.2V : When $V_{CC1} = 5V$) H level: Reverse (More than 2.8V : When $V_{CC1} = 5V$)
21 22	V_{H+} V_{H-}			Pin for supplying the hall bias current A voltage of approximately 1V is developed across (V_{H+}) and (V_{H-}).
23 24 25 26 27 28	U_{in1} U_{in2} V_{in1} V_{in2} W_{in1} W_{in2}	1.4V min 2.8V max (When $V_{CC1} = 5V$)		U phase hall element input pin Logic "H": $U_{in1} > U_{in2}$ V phase hall element input pin Logic "H": $V_{in1} > V_{in2}$ W phase hall element input pin Logic "H": $W_{in1} > W_{in2}$

Note) Pin 12 (NC pin) must be left open.

Sample Application Circuit

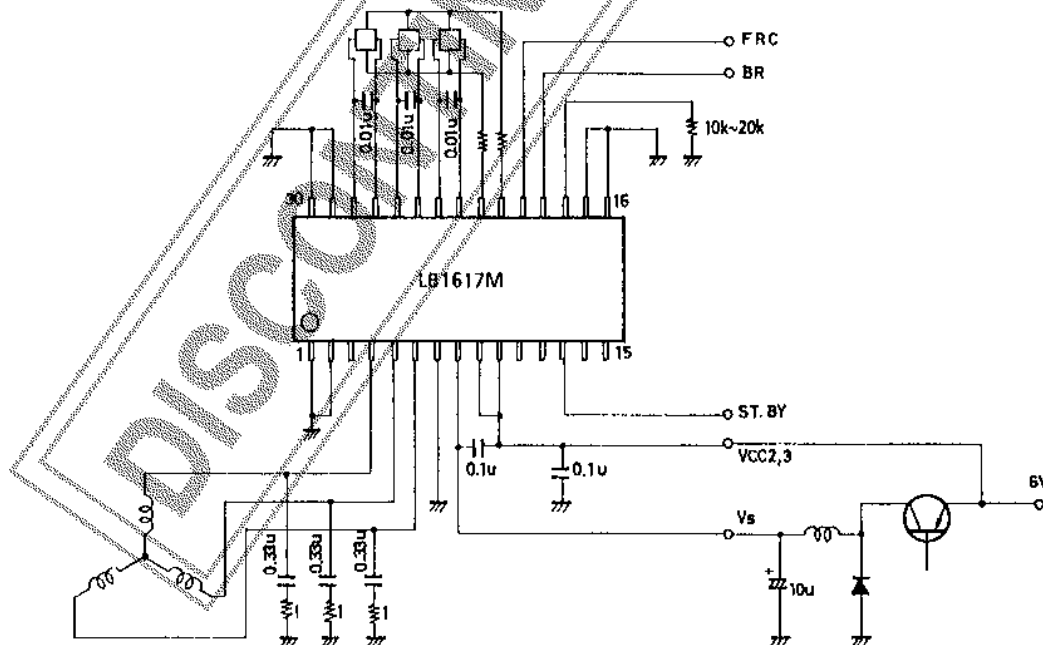

Output Voltage Waveform

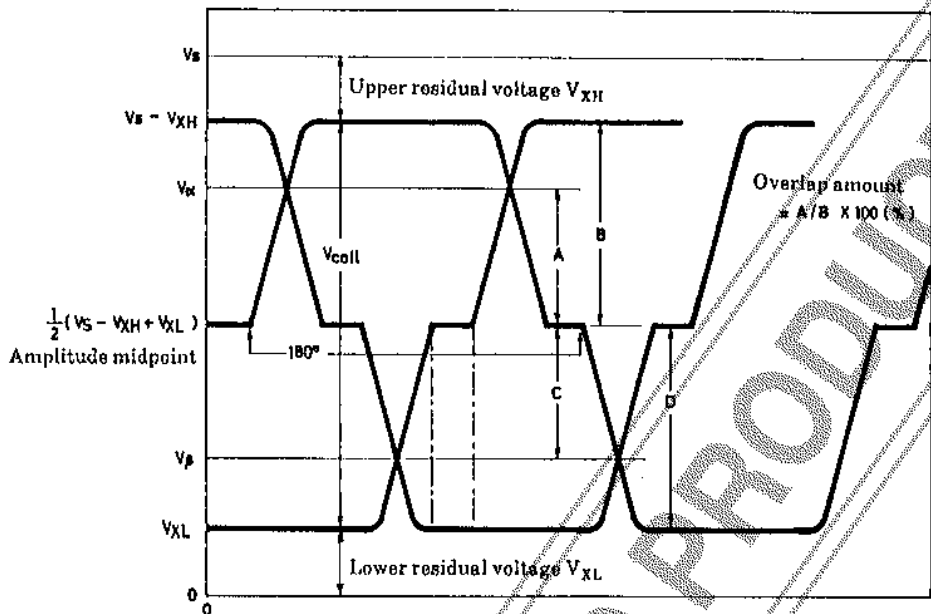

Upper overlap = $A/B = (2V_C - V_P - V_{XL}) / (V_P - V_{XL}) \times 100[\%]$
 Lower overlap = $C/D = (V_P + V_{XL} - 2V_C) / (V_P - V_{XL}) \times 100[\%]$

DISCONTINUED PRODUCT