



No. 4353

LB1672NM

Brushless-Sensorless Motor Driver

The LB1672NM is ideal IC for stereo headphone, micro cassette and mini cassette players applications.

Functions and Features

- Supports forward and reverse rotation
- On-chip speed control function (V-servo system)
- On-chip start/stop pin
- On-chip stabilized reference voltage (0.5 V)
- One on-chip comparator (NPN open collector output)
- Low voltage operation (1.0 V -)

Package Dimensions

unit : mm

3112-MFP24S

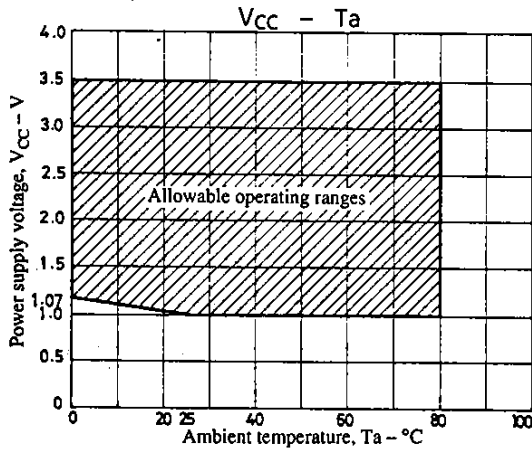
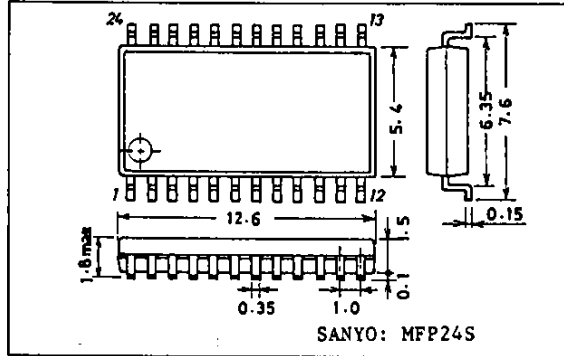

Pin Assignment

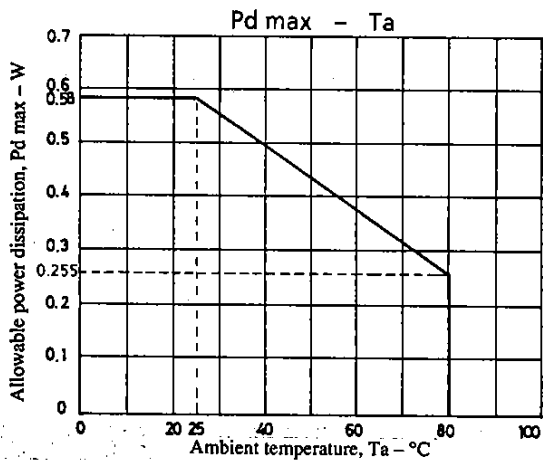
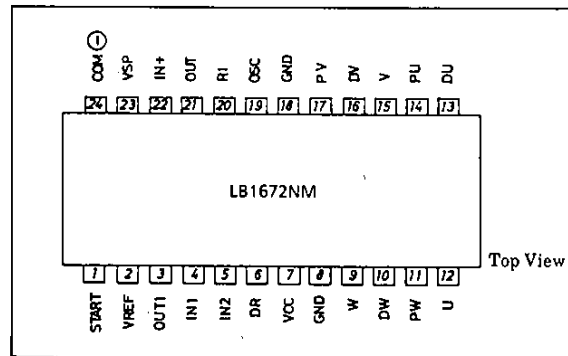

SANYO Electric Co., Ltd. Semiconductor Business Headquarters
 TOKYO OFFICE Tokyo Bldg., 1-10, 1 Chome, Ueno, Taito-ku, TOKYO, 110 JAPAN

Specifications

Absolute Maximum Ratings at Ta = 25°C

			unit
Maximum supply voltage	V _{CC} max	5	V
Output transistor pressure	V _{OTR} max	10	V
Maximum output current	I _M max	1	A
Allowable power dissipation	P _d max	0.58	W
Operating temperature	T _{opr}	Temperatures other than 25°C are shown in a separate diagram	0 to +80 °C
Storage temperature	T _{stg}	-40 to +125	°C

Allowable Operation Conditions at Ta = 25°C

			unit
Power supply voltage operating range	V _{CC} op	1.0 to 3.5	V

Electrical Characteristics at Ta = 25°C, V_{CC} = 1.5V, and the specified Test Circuit

			min	typ	max	unit
Supply current	I _{CC1}	START pin "H"		6	10	mA
	I _{CC2}	START pin "L"		0	10	μA
Reference voltage	V _{ref}		0.48	0.5	0.53	V
Reference voltage Voltage characteristics	$\frac{\Delta V_{ref}}{\Delta V_{CC}}$	V _{CC} = 1 to 3.5V		1	1.5	%/V
Reference voltage Load characteristics	$\frac{\Delta V_{ref}}{\Delta I_{ref}}$	I _{ref} = 0 to -60 μA	-0.1	-0.04		mV/μA
Reference voltage Temperature characteristics	$\frac{\Delta V_{ref}}{V_{ref}} / \Delta T_a$	T _a = 0 to 80°C		0.01		%/°C
Speed signal Detection accuracy	V _{sp}	V _{IN} = 500mV	125	135	145	mV
Speed signal Interphase error			-5		5	%
Speed signal Voltage characteristics	$\frac{\Delta V_{sp}}{V_{sp}} / \Delta V_{CC}$	V _{CC} = 1 to 3.5V		2	3	%/V
Speed signal Temperature characteristics	$\frac{\Delta V_{sp}}{V_{sp}} / \Delta T_a$	V _{IN} = 0.5V, T _a = 0 to +80°C		0.05		%/°C
Current detection accuracy	V _{RI}	V _{IN1} = 0.3V, V _{IN2} = 1V	100	120	137	mV
Current detection ratio	K _I	V _{IN1} = 0.3V, V _{IN2} = 1 to 1.3V	0.17	0.2	0.23	
Start pulse period	T _S	C _S = 2.2μF		55		ms
COM ⊖ lead-in current	I _{COM ⊖}		22	32	42	μA
Output saturation voltage	V _{sat}	V _{CC} = 1V, I _M = 0.2A		0.15	0.25	V
Logic input "H"-level voltage	V _H		0.9			V
Logic input "L"-level voltage	V _L				0.3	V
Comparator offset voltage	V _{OFF}		-10	0	10	mV
Comparator output current		V _{CC} = 1V, OUT1 = V _{CC}	100			μA

Equivalent Circuit Block Diagram

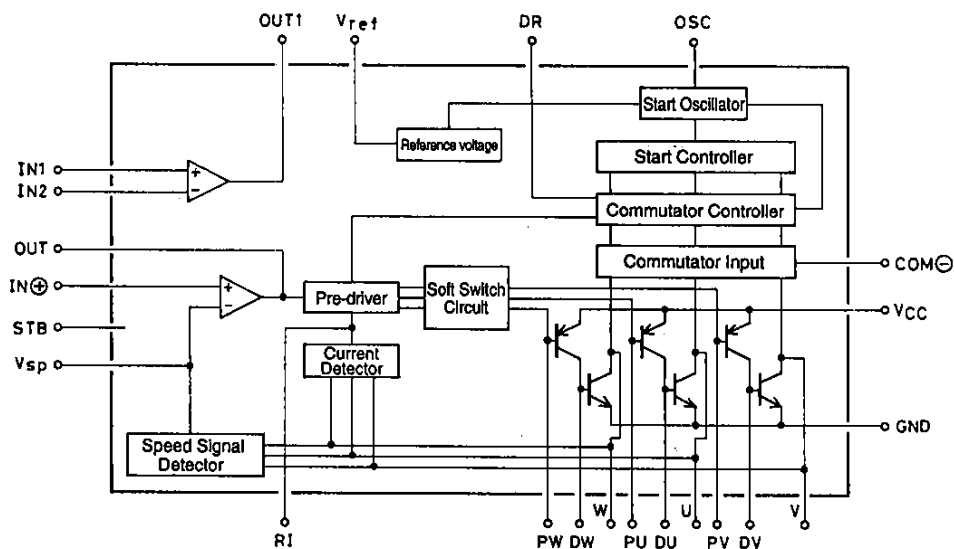

LB1672NM

Application Circuits Example

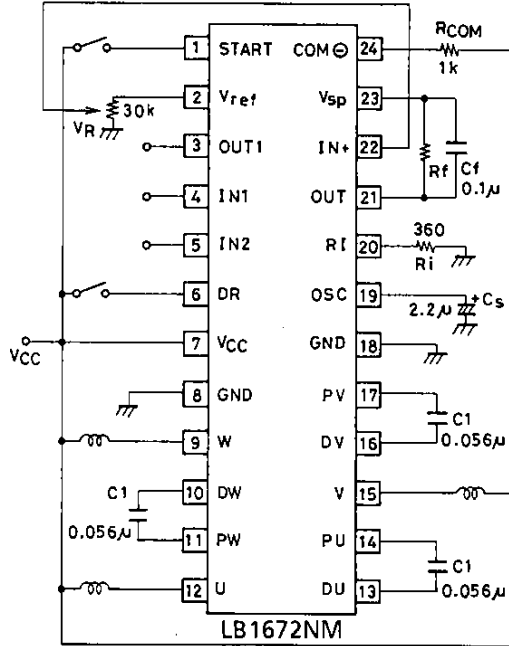

- When the resistance value of R_I increases and the capacitance between V_{CC} and GND is large ($1500\mu F$), oscillation elevates to the motor waveform.
- When the resistance value of R_I is excessively low, start voltage increases.
- The damping capacitor (C_1) for the output circuit should be as small as possible with C_S as large as possible.
- When the capacitor for the output circuit is large and C_S is small, start voltage increases with low temperatures.

Unit (resistance: Ω , capacitance: F)

Pin Descriptions

Pin Number	Pin Name	Functions
1	START	This pin is "H" active.
2	Vref	This pin is for reference voltage (0.5 V).
3	OUT1	This pin is for the on-chip comparator output (NPN open comparator).
4	IN1	This pin is for the on-chip comparator negative input (PNP base input).
5	IN2	This pin is for the on-chip comparator positive input (PNP base input).
6	DR	This pin is for switching rotation direction ("H" Initiates forward rotation)
7	VCC	This pin is for the power supply.
8	GND	This pin is for all circuit grounds.
9	W	This pin is for W-phase output.
10	DW	This pin is for the W-phase output transistor base.
11	PW	This pin is for the W-phase output predrive transistor base.
12	U	This pin is for the U-phase output.
13	DU	This pin is for the U-phase output transistor base.
14	PU	This pin is for the U-phase output predrive transistor base.
15	V	This pin is for the V-phase output.
16	DV	This pin is for the V-phase output transistor base.
17	PV	This pin is for the V-phase output predrive transistor base.
18	GND	This pin is the common for pin \textcircled{e} which is the pin for all circuit grounds.
19	OSC	This pin is for start pulse period setting.
20	R_i	This pin is for use in detecting motor current.
21	OUT	This pin is for speed signal error amplifier output. Motor current is returned.
22	IN \textcircled{e}	This pin is for speed signal error amplifier standard input.
23	Vsp	This pin is for detecting the speed signal (voltage induction).
24	COM \textcircled{e}	This pin performs a supporting role for the current control circuit during startup or when the rotational direction is changed.

- No products described or contained herein are intended for use in surgical implants, life-support systems, aerospace equipment, nuclear power control systems, vehicles, disaster/crime-prevention equipment and the like, the failure of which may directly or indirectly cause injury, death or property loss.
- Anyone purchasing any products described or contained herein for an above-mentioned use shall:
 - ① Accept full responsibility and indemnify and defend SANYO ELECTRIC CO., LTD., its affiliates, subsidiaries and distributors and all their officers and employees, jointly and severally, against any and all claims and litigation and all damages, cost and expenses associated with such use:
 - ② Not impose any responsibility for any fault or negligence which may be cited in any such claim or litigation on SANYO ELECTRIC CO., LTD., its affiliates, subsidiaries and distributors or any of their officers and employees jointly or severally.
- Information (including circuit diagrams and circuit parameters) herein is for example only; it is not guaranteed for volume production. SANYO believes information herein is accurate and reliable, but no guarantees are made or implied regarding its use or any infringements of intellectual property rights or other rights of third parties.