



Low-Saturation Bidirectional Motor Drive for Low-Voltage Applications

Overview

The LB1638, 1638M are low-saturation bidirectional motor driver ICs for use in low-voltage applications. At an I_O of 500 mA, they have a low saturation output of $V_O(\text{sat}) = 0.75$ V. They are especially suited for use in compact motor of portable equipment.

Features

- Low voltage operation (2.5 V min.)
- Low saturation voltage (upper transistor + lower transistor residual voltage; at $I_O = 500$ mA, $V_O(\text{sat}) = 0.75$ V typ.)
- Low current drain at standby mode ($I_{CC0} = 0.1$ μ A typ. or less)
- Separate logic power supply and motor power supply
- Brake function
- Built-in spark killer diodes
- Compact package (MFP-10S) suited for surface mounting.

Package Dimensions

unit : mm

3098B-DIP10S

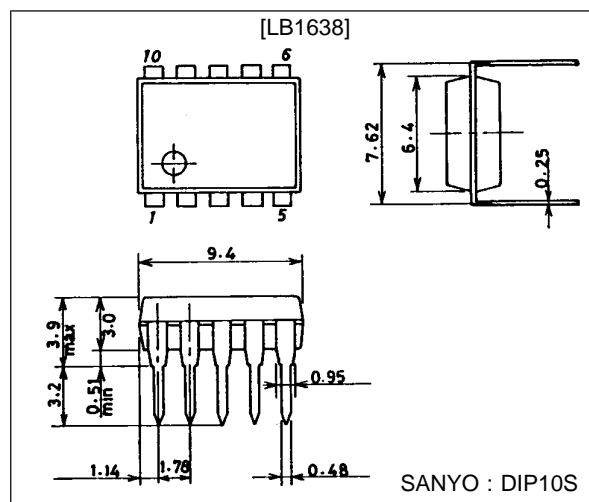

unit : mm

3086A-MFP10S

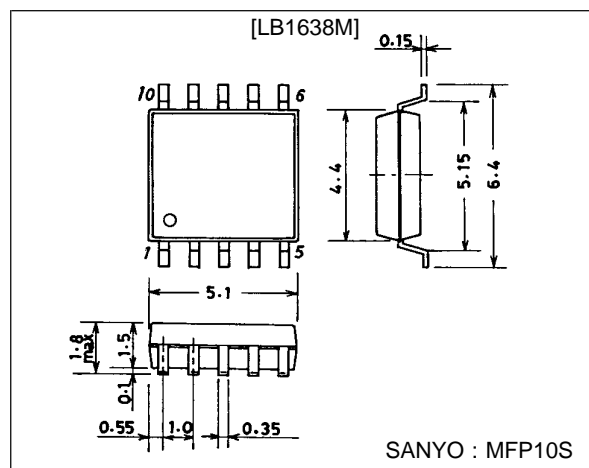

LB1638, 1638M

Specifications

Absolute Maximum Ratings at $T_a = 25\text{ }^\circ\text{C}$

Parameter	Symbol	Conditions	Ratings	Unit
Maximum supply voltage	$V_{CC\text{ max}}$		-0.3 to +10.5	V
	$V_S\text{ max}$		-0.3 to +10.5	V
Output applied voltage	V_{OUT}		-0.3 to $V_S + V_F$	V
Input applied voltage	V_{IN}		-0.3 to +10.0	V
Ground pin flow-out current	I_{GND}		1.0	A
Allowable power dissipation	$P_d\text{ max}$	LB1638	1.0	W
		LB1638M: Independent IC	440	mW
		LB1638M: *With board	550	mW
Operating temperature	T_{opr}		-20 to +75	$^\circ\text{C}$
Storage temperature	T_{stg}		-40 to +125	$^\circ\text{C}$

* Specified board ($30 \times 30 \times 1.5\text{ mm}^3$ glass epoxy)

Allowable Operating Ranges at $T_a = 25\text{ }^\circ\text{C}$

Parameter	Symbol	Conditions	Ratings	Unit
Supply voltage range	V_{CC}		2.5 to 9.0	V
	V_S		2.2 to 9.0	V
Input high-level voltage	V_{IH}		2.0 to 9.0	V
Input low-level voltage	V_{IL}		-0.3 to +0.7	V

Electrical Characteristics at $T_a = 25\text{ }^\circ\text{C}$, $V_{CC} = V_S = 3\text{ V}$

Parameter	Symbol	Conditions	min	typ	max	Unit
Current drain	I_{CC0}	$V_{IN}\ 1, 2$ $I_{CC} + I_S$			10	μA
	I_{CC1}	$V_{IN}\ 1 = 3\text{ V}, V_{IN}\ 2 = 0\text{ V}$ $I_{CC} + I_S$			20	mA
	I_{CC2}	$V_{IN}\ 1, 2 = 3\text{ V}$ $I_{CC} + I_S$			40	mA
Output saturation voltage (upper + lower)	V_{OUT1}	$I_{OUT} = 200\text{ mA}$		0.25	0.5	V
	V_{OUT2}	$I_{OUT} = 500\text{ mA}$		0.70	1.3	V
Output pin voltage difference		$I_O = 200\text{ mA}$			0.1	V
Output sustain voltage	$V_O\text{ (sus)}$	$I_{OUT} = 500\text{ mA}$	9			V
Input current	I_{IN}	$V_{IN} = 7\text{ V}, V_{CC} = 7\text{ V}$			0.5	mA
[Spark killer diode]						
Reverse current	$I_S\text{ (leak)}$	$V_{CC}, V_S = 7\text{ V}$			10	μA
Forward voltage	V_{SF}	$I_{OUT} = 200\text{ mA}$			1.7	V

Pin Assignment

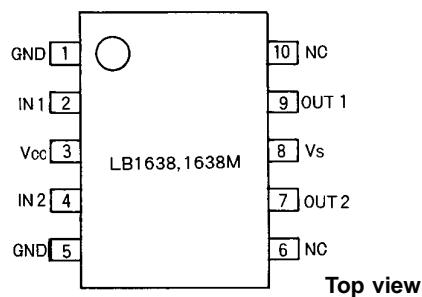

Note: both ground pins must be grounded.

Truth Table

IN 1	IN 2	OUT 1	OUT 2	Mode
H	L	H	L	Forward
L	H	L	H	Reverse
H	H	L	L	Brake
L	L	OFF	OFF	Standby

Sample Application Circuit

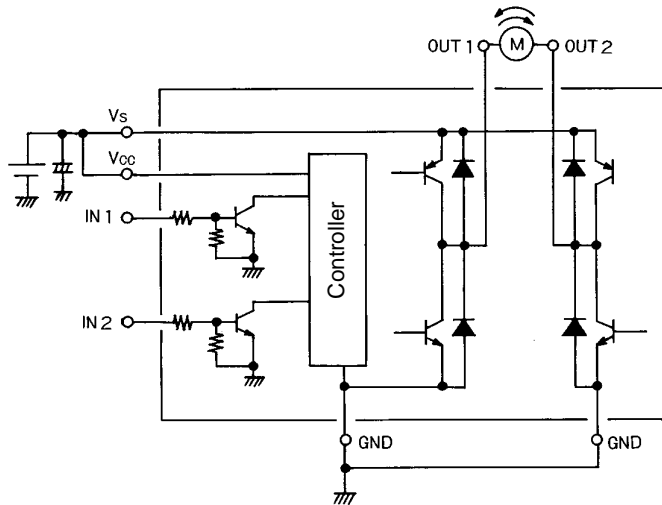

Note: When using the same power supply for V_S and V_{CC} , short the V_{CC} and V_S pins to each other or insert a capacitor in the V_{CC} line.

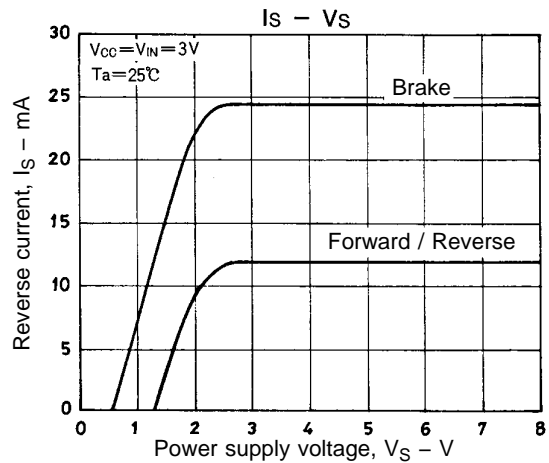
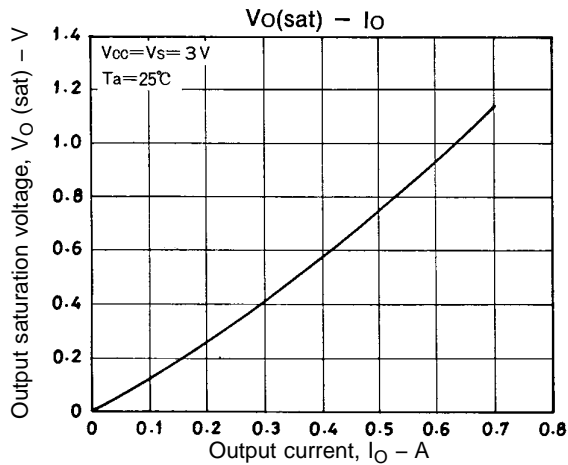

LB1638, 1638M

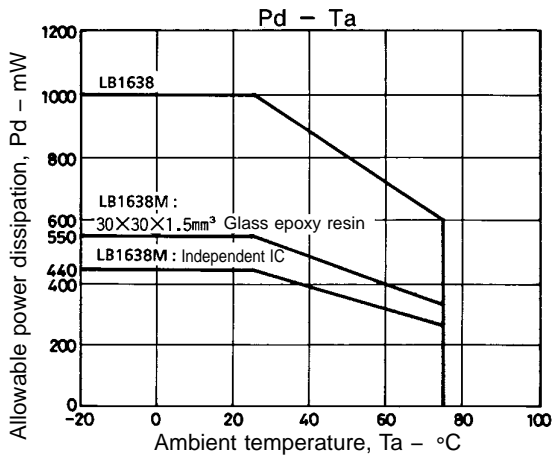
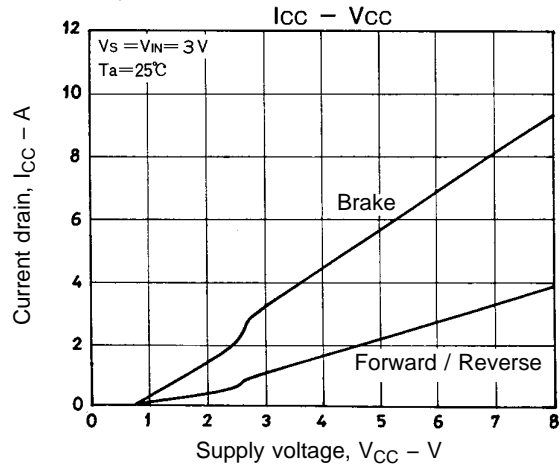
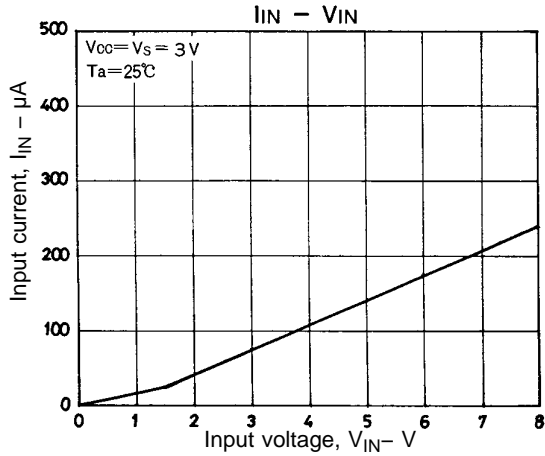

- No products described or contained herein are intended for use in surgical implants, life-support systems, aerospace equipment, nuclear power control systems, vehicles, disaster/crime-prevention equipment and the like, the failure of which may directly or indirectly cause injury, death or property loss.
- Anyone purchasing any products described or contained herein for an above-mentioned use shall:
 - ① Accept full responsibility and indemnify and defend SANYO ELECTRIC CO., LTD., its affiliates, subsidiaries and distributors and all their officers and employees, jointly and severally, against any and all claims and litigation and all damages, cost and expenses associated with such use:
 - ② Not impose any responsibility for any fault or negligence which may be cited in any such claim or litigation on SANYO ELECTRIC CO., LTD., its affiliates, subsidiaries and distributors or any of their officers and employees jointly or severally.
- Information (including circuit diagrams and circuit parameters) herein is for example only; it is not guaranteed for volume production. SANYO believes information herein is accurate and reliable, but no guarantees are made or implied regarding its use or any infringements of intellectual property rights or other rights of third parties.

This catalog provides information as of July, 1996. Specifications and information herein are subject to change without notice.