



## 2-Phase Unipolar Brushless Motor Drivers

### Applications

2-Phase unipolar brushless motor (ex. DC brushless fan motor) drivers

### Features and Functions

- Protection against motor lock and automatic return can be provided with a minimum number of external parts.
- The LB1663, LB1663M, LB1666 can be operated from either 12 V or 24 V power supply by changing an external resistor.
- Possible to connect a Hall element direct to the LB1663, LB1663M, LB1666.
- Built-in output transistors with output current 1.5 A.
- Built-in rotation detect function (Drive mode: "L", Stop mode: "H")
- Built-in thermal shutdown
- With radio noise reduction pin

### Package Dimensions

unit : mm

#### 3098A - DIP10S

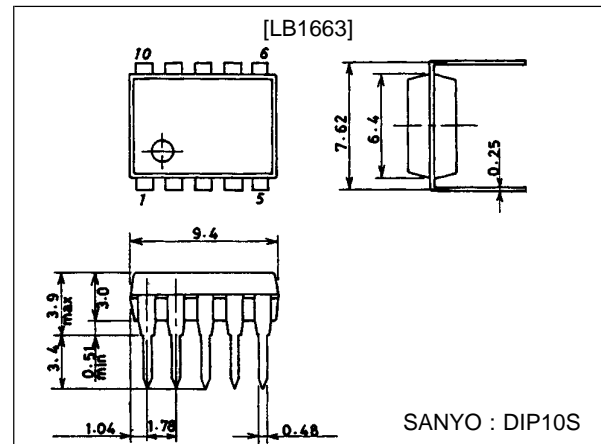

unit : mm

#### 3054A - DIP16F

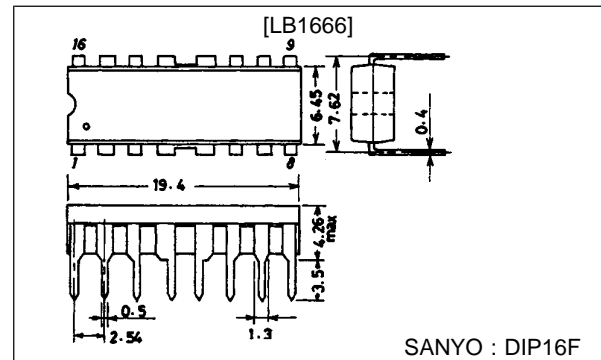

unit : mm

#### 3097 - MFP16FS

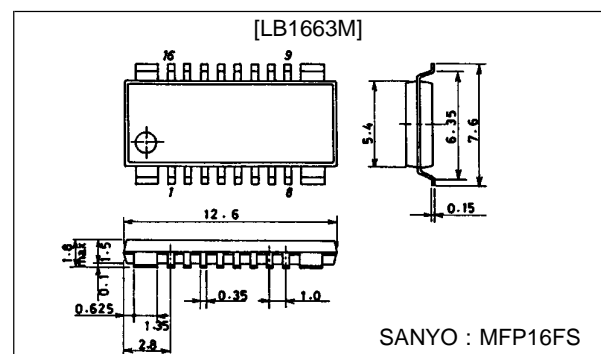

## Specifications

### [LB1663]

#### Absolute Maximum Ratings at $T_a = 25^\circ\text{C}$

| Parameter                   | Symbol       | Conditions     | Ratings     | Unit             |
|-----------------------------|--------------|----------------|-------------|------------------|
| Maximum input current       | $I_{CC}$ max | $t \leq 20$ ms | 200         | mA               |
| Output supply voltage       | $V_O$ max    |                | -0.3 to +85 | V                |
| Maximum output current      | $I_O$ max    |                | 1.5         | A                |
| RD flow-in current          | $I_{RD}$     |                | 10          | mA               |
| RD supply voltage           | $V_{RD}$     |                | 50          | V                |
| Allowable power dissipation | $P_d$ max    |                | 1.2         | W                |
| Operating temperature       | $T_{opr}$    |                | -30 to +80  | $^\circ\text{C}$ |
| Storage temperature         | $T_{stg}$    |                | -55 to +125 | $^\circ\text{C}$ |

#### Allowable Operating Ranges at $T_a = 25^\circ\text{C}$

| Parameter                       | Symbol    | Conditions | Rating              | Unit |
|---------------------------------|-----------|------------|---------------------|------|
| Input current range             | $I_{CC}$  |            | 6.0 to 50.0         | mA   |
| Common-mode input voltage range | $V_{ICM}$ |            | 0 to $V_{IN} - 1.5$ | V    |

#### Electrical Characteristics at $T_a = 25^\circ\text{C}$ , $I_{CC} = 10$ mA

| Parameter                          | Symbol         | Conditions        | min  | typ           | max  | Unit          |
|------------------------------------|----------------|-------------------|------|---------------|------|---------------|
| Output withstand voltage 1         | $V_{OR}$       |                   | 80   |               |      | V             |
| Output withstand voltage 2         | $V_O$ (sus)    | $I_O = 0.1$ A     | 65   |               |      | V             |
| Output saturation voltage          | $V_O$ (sat)1   | $I_O = 0.5$ A     |      | 0.95          | 1.20 | V             |
|                                    | $V_O$ (sat)2   | $I_O = 1.0$ A     |      | 1.15          | 1.50 | V             |
|                                    | $V_O$ (sat)3   | $I_O = 1.5$ A     |      | 1.40          | 2.00 | V             |
| $V_{IN}$ input voltage             | $V_{IN}$       | $I_{CC} = 7.0$ mA | 6.4  | 6.7           | 7.0  | V             |
| Amp input offset voltage           | $V_{off}$      |                   | -7   | 0             | +7   | mV            |
| Amp input bias current             | $I_{BA}$       |                   | -250 |               |      | nA            |
| RD output saturation voltage       | $V_{RD}$ (sat) | $I_{RD} = 5$ mA   |      | 0.1           | 0.2  | V             |
| C flow-out current                 | $I_{C1}$       |                   | 2.1  | 3.0           | 3.9  | $\mu\text{A}$ |
| C discharge current                | $I_{C2}$       |                   | 0.31 | 0.44          | 0.59 | $\mu\text{A}$ |
| Comparator input threshold voltage | $V_{TH1}$      |                   | 0.77 | $0.8 V_{IN}$  | 0.83 | V             |
|                                    | $V_{TH2}$      |                   | 0.42 | $0.45 V_{IN}$ | 0.48 | V             |

### [LB1663M] = Preliminary

#### Absolute Maximum Ratings at $T_a = 25^\circ\text{C}$

| Parameter                   | Symbol       | Conditions             | Ratings     | Unit             |
|-----------------------------|--------------|------------------------|-------------|------------------|
| Maximum input current       | $I_{CC}$ max | $t \leq 20$ ms         | 200         | mA               |
| Output supply voltage       | $V_O$ max    |                        | -0.3 to +85 | V                |
| Maximum output current      | $I_O$ max    |                        | 1.5         | A                |
| RD flow-in current          | $I_{RD}$     |                        | 10          | mA               |
| RD supply voltage           | $V_{RD}$     |                        | 50          | V                |
| Allowable power dissipation | $P_d$ max    |                        | 0.9         | W                |
|                             |              | * With specified board | 1.2         | W                |
| Operating temperature       | $T_{opr}$    |                        | -30 to +80  | $^\circ\text{C}$ |
| Storage temperature         | $T_{stg}$    |                        | -55 to +125 | $^\circ\text{C}$ |

\* Note:  $20 \times 30 \times 1.5$  mm<sup>3</sup> glass epoxy board

## LB1663, 1663M, 1666

### Allowable Operating Ranges at $T_a = 25^\circ\text{C}$

| Parameter                       | Symbol    | Conditions | Ratings           | Unit |
|---------------------------------|-----------|------------|-------------------|------|
| Input current range             | $I_{CC}$  |            | 6.0 to 50.0       | mA   |
| Common-mode input voltage range | $V_{ICM}$ |            | 0 to $V_{IN}-1.5$ | V    |

### Electrical Characteristics at $T_a = 25^\circ\text{C}$ , $I_{CC} = 10\text{ mA}$

| Parameter                          | Symbol         | Conditions               | min  | typ           | max  | Unit          |
|------------------------------------|----------------|--------------------------|------|---------------|------|---------------|
| Output withstand voltage 1         | $V_{OR}$       |                          | 80   |               |      | V             |
| Output withstand voltage 2         | $V_O$ (sus)    | $I_O = 0.1\text{ A}$     | 65   |               |      | V             |
| Output saturation voltage          | $V_O$ (sat)1   | $I_O = 0.5\text{ A}$     |      | 0.95          | 1.20 | V             |
|                                    | $V_O$ (sat)2   | $I_O = 1.0\text{ A}$     |      | 1.15          | 1.50 | V             |
|                                    | $V_O$ (sat)3   | $I_O = 1.5\text{ A}$     |      | 1.40          | 2.00 | V             |
| $V_{IN}$ input voltage             | $V_{IN}$       | $I_{CC} = 7.0\text{ mA}$ | 6.4  | 6.7           | 7.0  | V             |
| Amp input offset voltage           | V off          |                          | -7   | 0             | +7   | mV            |
| Amp input bias current             | $I_{BA}$       |                          | -250 |               |      | nA            |
| RD output saturation voltage       | $V_{RD}$ (sat) | $I_{RD} = 5\text{ mA}$   |      | 0.1           | 0.2  | V             |
| C flow-out current                 | $I_{C1}$       |                          | 2.1  | 3.0           | 3.9  | $\mu\text{A}$ |
| C discharge current                | $I_{C2}$       |                          | 0.31 | 0.44          | 0.59 | $\mu\text{A}$ |
| Comparator input threshold voltage | $V_{TH1}$      |                          | 0.77 | $0.8 V_{IN}$  | 0.83 | V             |
|                                    | $V_{TH2}$      |                          | 0.42 | $0.45 V_{IN}$ | 0.48 | V             |

### [LB1666]

### Absolute Maximum Ratings at $T_a = 25^\circ\text{C}$

| Parameter                   | Symbol       | Conditions            | Ratings     | Unit             |
|-----------------------------|--------------|-----------------------|-------------|------------------|
| Maximum input current       | $I_{CC}$ max | $t \leq 20\text{ ms}$ | 200         | mA               |
| Output supply voltage       | $V_O$ max    |                       | -0.3 to +85 | V                |
| Maximum output current      | $I_O$ max    |                       | 1.5         | A                |
| RD flow-in current          | $I_{RD}$     |                       | 10          | mA               |
| RD supply voltage           | $V_{RD}$     |                       | 50          | V                |
| Allowable power dissipation | $P_d$ max    |                       | 2.0         | W                |
| Operating temperature       | $T_{opr}$    |                       | -30 to +80  | $^\circ\text{C}$ |
| Storage temperature         | $T_{stg}$    |                       | -55 to +125 | $^\circ\text{C}$ |

### Allowable Operating Ranges at $T_a = 25^\circ\text{C}$

| Parameter                       | Symbol    | Conditions | Ratings           | Unit |
|---------------------------------|-----------|------------|-------------------|------|
| Input current range             | $I_{CC}$  |            | 6.0 to 50.0       | mA   |
| Common-mode input voltage range | $V_{ICM}$ |            | 0 to $V_{IN}-1.5$ | V    |

### Electrical Characteristics at $T_a = 25^\circ\text{C}$ , $I_{CC} = 10\text{ mA}$

| Parameter                          | Symbol         | Conditions               | min  | typ           | max  | Unit          |
|------------------------------------|----------------|--------------------------|------|---------------|------|---------------|
| Output withstand voltage 1         | $V_{OR}$       |                          | 80   |               |      | V             |
| Output withstand voltage 2         | $V_O$ (sus)    | $I_O = 1.0\text{ A}$     | 65   |               |      | V             |
| Output saturation voltage          | $V_O$ (sat)1   | $I_O = 0.5\text{ A}$     |      | 0.95          | 1.20 | V             |
|                                    | $V_O$ (sat)2   | $I_O = 1.0\text{ A}$     |      | 1.15          | 1.50 | V             |
|                                    | $V_O$ (sat)3   | $I_O = 1.5\text{ A}$     |      | 1.40          | 2.00 | V             |
| $V_{IN}$ input voltage             | $V_{IN}$       | $I_{CC} = 7.0\text{ mA}$ | 6.4  | 6.7           | 7.0  | V             |
| Amp input offset voltage           | V off          |                          | -7   | 0             | +7   | mV            |
| Amp input bias current             | $I_{BA}$       |                          | -250 |               |      | nA            |
| RD output saturation voltage       | $V_{RD}$ (sat) | $I_{RD} = 5\text{ mA}$   |      | 0.1           | 0.2  | V             |
| C flow-out current                 | $I_{C1}$       |                          | 2.1  | 3.0           | 3.9  | $\mu\text{A}$ |
| C discharge current                | $I_{C2}$       |                          | 0.21 | 0.30          | 0.39 | $\mu\text{A}$ |
| Comparator input threshold voltage | $V_{TH1}$      |                          | 0.77 | $0.8 V_{IN}$  | 0.83 | V             |
|                                    | $V_{TH2}$      |                          | 0.42 | $0.45 V_{IN}$ | 0.48 | V             |

# LB1663, 1663M, 1666

## Pin Assignment

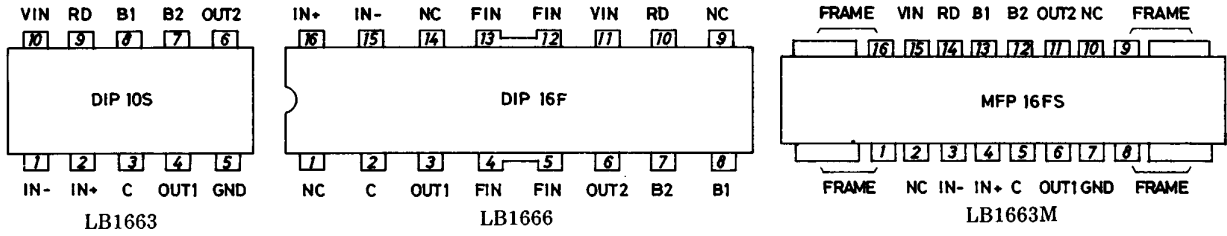

Top view

## Equivalent Circuit Block Diagram and Sample Application Circuit

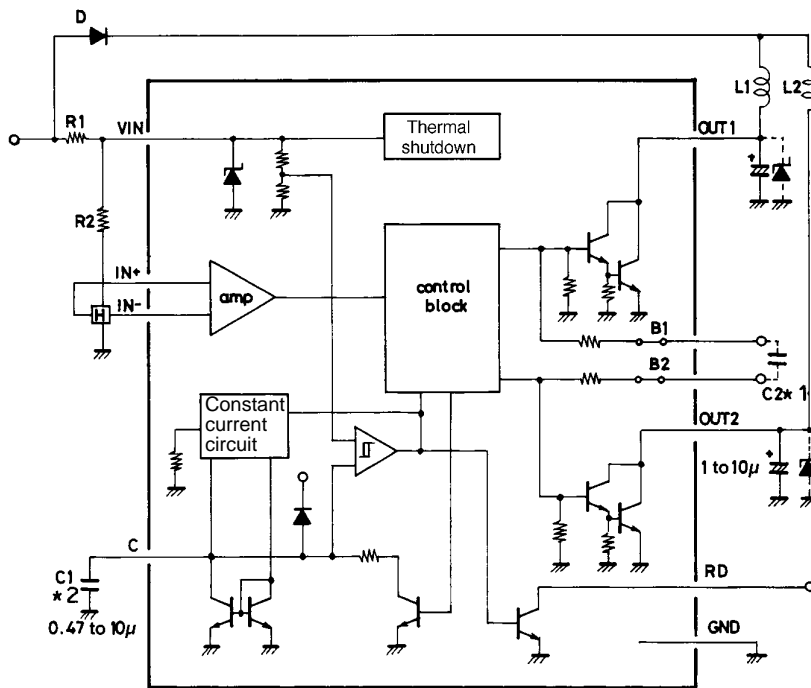

(Note) \*1: Radio noise reduction capacitor: 0.01 to 0.1  $\mu$ F.  
 \*2: Use a less leaky capacitor.

# LB1663, 1663M, 1666

## Truth Table

| IN+ | IN- | C | OUT1 | OUT2 |
|-----|-----|---|------|------|
| H   | L   | L | H    | L    |
| L   | H   | L | L    | H    |
| H   | L   | H | H    | H    |
| L   | H   | H | H    | H    |

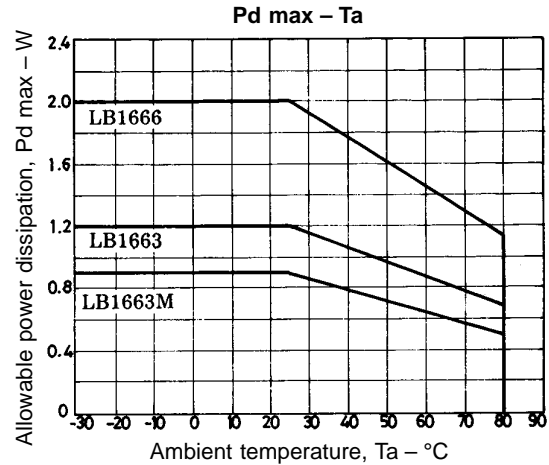

## Output Protection

|                             |                                |                  |
|-----------------------------|--------------------------------|------------------|
| For C marked with 1 $\mu$ F | Lock detect time               | Approximately 2s |
|                             | Lock protect time (output on)  | Approximately 1s |
|                             | Lock protect time (output off) | Approximately 6s |

## Pin Description

| Pin Name     | Function   |
|--------------|--|
| $V_{IN}$     | A limiting resistor is connected across $V_{CC}$ and $V_{IN}$ to adjust the current flowing into $V_{IN}$ to be 6 mA to 50 mA, which generates a voltage (6.7 V) on this pin and supplies a regulated voltage to the IC system and a Hall element.   |
| IN+<br>IN-   | Pins for accepting output from Hall element.<br>Common-mode input voltage range: 0 to $V_{IN}-1.5$ V<br>Offset voltage: $\pm 7$ mV   |
| OUT1<br>OUT2 | Output transistors of output pins are Darlington-connected. External capacitors or Zener diodes must be connected to protect output transistors.   |
| RD           | Open collector output (Drive mode - "L", Stop mode - "H")  |
| B1<br>B2     | Base pins for output transistors of Darlington connection.<br>A capacitor must be connected in an application where radio noise becomes a problem.   |
| C            | Capacitor pin for automatic return function<br>When the rotation is stopped by an overload, the voltage on this pin is increased, turning OFF the output. Automatic return from output "stop" to "drive" occurs by making the load proper. The lock detect time can be set by changing the capacitor constant. |
| GND          | Ground   |

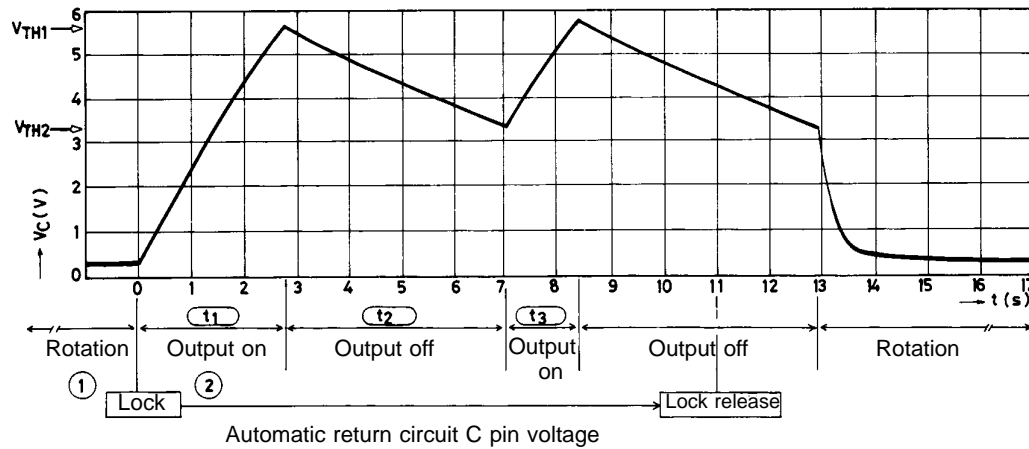

- ① When a fan is rotating, the capacitor is charged at 3  $\mu$ A (typ) and discharged through the C with pulses according to the rotational speed.
- ② When a fan is locked, no discharge occurs through the C and the C voltage rises, turning OFF the output at  $0.8 \times V_{IN}$ .
- ③ When the output is turned OFF, discharge occurs through the C at 0.44  $\mu$ A (typ). If the lock is not released when the C voltage drops to  $V_{TH2}$ , the capacitor is charged to  $V_{TH1}$  again. (At this moment, the output is turned ON.)  
These operations ②, ③ repeated on a cycle of approximately  $t_{on} : t_{off} = 1 : 6$  protect a motor.
- ④ If the lock is released when the C voltage drops to  $V_{TH2}$ , the output is turned ON, starting rotation.

■ No products described or contained herein are intended for use in surgical implants, life-support systems, aerospace equipment, nuclear power control systems, vehicles, disaster/crime-prevention equipment and the like, the failure of which may directly or indirectly cause injury, death or property loss.

■ Anyone purchasing any products described or contained herein for an above-mentioned use shall:

- ① Accept full responsibility and indemnify and defend SANYO ELECTRIC CO., LTD., its affiliates, subsidiaries and distributors and all their officers and employees, jointly and severally, against any and all claims and litigation and all damages, cost and expenses associated with such use:
- ② Not impose any responsibility for any fault or negligence which may be cited in any such claim or litigation on SANYO ELECTRIC CO., LTD., its affiliates, subsidiaries and distributors or any of their officers and employees jointly or severally.

■ Information (including circuit diagrams and circuit parameters) herein is for example only; it is not guaranteed for volume production. SANYO believes information herein is accurate and reliable, but no guarantees are made or implied regarding its use or any infringements of intellectual property rights or other rights of third parties.

This catalog provides information as of November, 1997. Specifications and information herein are subject to change without notice.