



LB1855NM

3-Phase Brushless Motor Driver

Overview

The LB1855NM is a 3-phase brushless motor driver IC that is optimal for VCR drum motor drive.

Features

- Current linear drive
- No output electrolytic capacitors required.

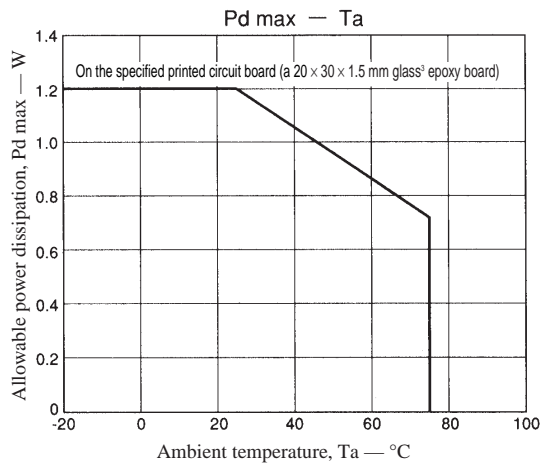

- Current limiter circuit built in
- AGC circuit built in
- Thermal shutdown circuit built in

Package Dimensions

unit: mm

3097-MFP16FS

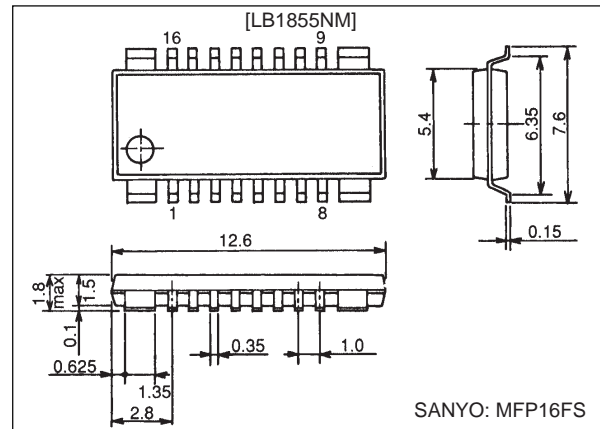

Specifications

Absolute Maximum Ratings at Ta = 25°C

Parameter	Symbol	Conditions	Ratings	Unit
Maximum supply voltage	V _{CC} max		20	V
Maximum output current	I _O max		1.2	A
Allowable power dissipation	Pd max	On the specified printed circuit board (a 20 × 30 × 1.5 mm ³ glass epoxy board)	1.2	W
Operating temperature	T _{opr}		-20 to +75	°C
Storage temperature	T _{stg}		-55 to +150	°C

Allowable Operating Ranges at Ta = 25°C

Parameter	Symbol	Conditions	Ratings	Unit
Supply current	V _{CC}		7 to 18	V
Hall input amplitude	V _{HALL}	Between the Hall inputs	70 to 300	mVp-p

■ Any and all SANYO products described or contained herein do not have specifications that can handle applications that require extremely high levels of reliability, such as life-support systems, aircraft's control systems, or other applications whose failure can be reasonably expected to result in serious physical and/or material damage. Consult with your SANYO representative nearest you before using any SANYO products described or contained herein in such applications.

■ SANYO assumes no responsibility for equipment failures that result from using products at values that exceed, even momentarily, rated values (such as maximum ratings, operating condition ranges, or other parameters) listed in products specifications of any and all SANYO products described or contained herein.

SANYO Electric Co., Ltd. Semiconductor Business Headquarters

TOKYO OFFICE Tokyo Bldg., 1-10, 1 Chome, Ueno, Taito-ku, TOKYO, 110-8534 JAPAN

O3098RM (OT) No. 5798-1/5

LB1855NM

Electrical Characteristics at $T_a = 25^\circ\text{C}$, $V_{CC} = 12\text{ V}$

Parameter	Symbol	Conditions	Ratings			Unit
			min	typ	max	
Supply current	I_{CC}	$V_C = \text{GND}$			8	mA
Reference voltage	V_{REF}	$I_R = 8\text{ mA}$	6.0	6.3	6.6	V
[Saturation voltage]						
Upper side	V_{sat1}	$I_O = 1\text{ A}$		1.5	1.9	V
Lower side	V_{sat2}	$I_O = 1\text{ A}$		0.8	1.2	V
[Leakage current]						
Upper side	I_{OL1}	$V_{CC} = 18\text{ V}$			50	μA
Lower side	I_{OL2}	$V_{CC} = 18\text{ V}$			50	μA
[Hall Amplifier]						
Input offset voltage	V_{HO}	*	-10		+10	mV
Common-mode input voltage range	V_{HCM}		2.2		$V_{CC} - 0.7$	V
[Control Amplifier]						
Control reference voltage	V_{REF1}	(the V_{CREF} pin voltage) $\times 23/16$	2.1	2.3	2.5	V
Control Gm	V_G	$R_f = 1\Omega$		1		A/V
Input current	I_{IN}				10	μA
[Thermal Shutdown Circuit]						
Operating temperature	T_{TSD}	*		180		$^\circ\text{C}$
Hysteresis	ΔT_{TSD}	*		15		$^\circ\text{C}$

Note: Items marked with an asterisk (*) are design target values and are not tested.

Pin Assignment

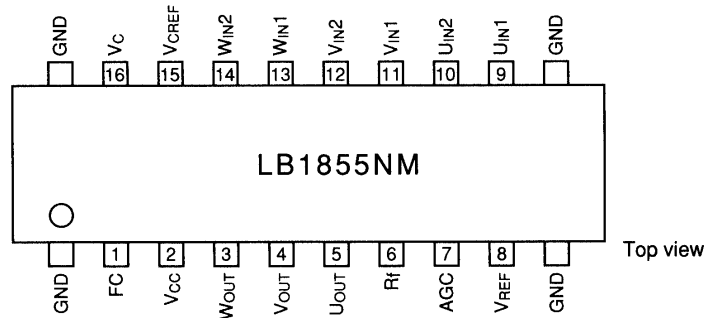

Block Diagram

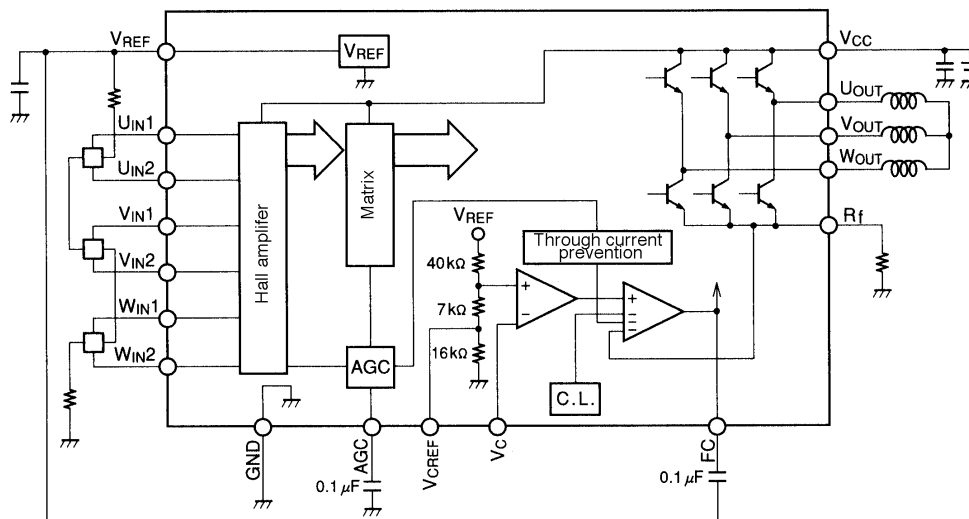

However, note that certain motors may require output capacitors to prevent oscillation.

LB1855NM

Sample Application Circuit

Hall input voltage range: 2.2 to ($V_{CC} - 0.7$) V DC

70 mV p-p to 300 mV p-p AC

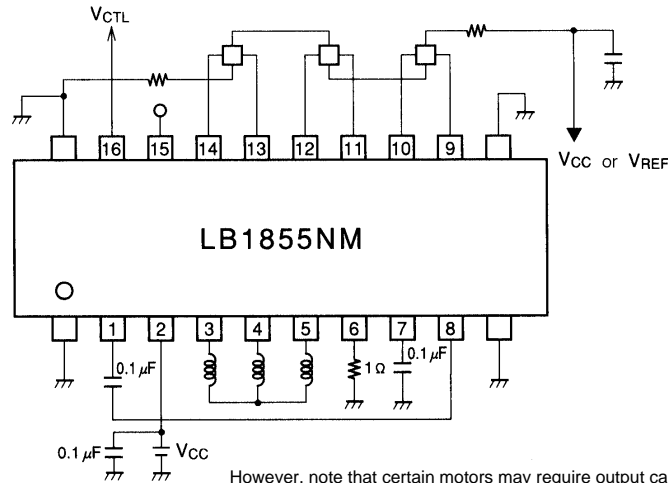

However, note that certain motors may require output capacitors to prevent oscillation.

Truth Table

Item	Source → sink	Input		
		U	V	W
1	V phase → W phase	H	H	L
2	U phase → W phase	H	L	L
3	W phase → V phase	L	L	H
4	V phase → U phase	L	H	L
5	U phase → V phase	H	L	H
6	W phase → U phase	L	H	H

Input: "H" indicates that the input phase 1 is at least 0.2 V higher than phase 2.

"L" indicates that the input phase 1 is at least 0.2 V lower than phase 2.

Pin Functions

Pin No.	Pin	Pin voltage (V)	Pin description	Equivalent circuit
1	FC		<ul style="list-style-type: none"> Frequency characteristics correction Oscillation in the current control closed loop can be prevented by inserting a capacitor between this pin and VREF. 	
2	V _{CC}	7 to 18	<ul style="list-style-type: none"> Power supply pin 	
3 4 5	W _{OUT} V _{OUT} U _{OUT}		<ul style="list-style-type: none"> Outputs pin 	
6	R _f		<ul style="list-style-type: none"> Ground for the output transistor The output current can be detected as a voltage by inserting the resistor R_f between this pin and ground to provide fixed current drive. The current limiter also operates by detecting this voltage. 	

Continued on next page.

LB1855NM

Continued from preceding page.

Pin No.	Pin	Pin voltage (V)	Pin description	Equivalent circuit
7	AGC		<ul style="list-style-type: none"> AGC pin The Hall amplifier gain can be controlled according to the amplitude of the Hall input by inserting a capacitor between this pin and ground. 	
8	V _{REF}		<ul style="list-style-type: none"> Internal reference voltage. About 6.3 V. 	
9 10 11 12 13 14	U _{IN1} U _{IN2} V _{IN1} V _{IN2} W _{IN1} W _{IN2}	2.2 to V _{CC} - 0.7	<ul style="list-style-type: none"> Hall element inputs pin 	
15 16	V _{CREF} V _C	0 to 5	<ul style="list-style-type: none"> Speed control pin This IC adopts a current control type in which the output current is controlled by the pin 16 voltage. The control start voltage changes about 1.3 to 1.4 V if pin 15 is connected to ground. 	

- Specifications of any and all SANYO products described or contained herein stipulate the performance, characteristics, and functions of the described products in the independent state, and are not guarantees of the performance, characteristics, and functions of the described products as mounted in the customer's products or equipment. To verify symptoms and states that cannot be evaluated in an independent device, the customer should always evaluate and test devices mounted in the customer's products or equipment.
- SANYO Electric Co., Ltd. strives to supply high-quality high-reliability products. However, any and all semiconductor products fail with some probability. It is possible that these probabilistic failures could give rise to accidents or events that could endanger human lives, that could give rise to smoke or fire, or that could cause damage to other property. When designing equipment, adopt safety measures so that these kinds of accidents or events cannot occur. Such measures include but are not limited to protective circuits and error prevention circuits for safe design, redundant design, and structural design.
- In the event that any or all SANYO products (including technical data, services) described or contained herein are controlled under any of applicable local export control laws and regulations, such products must not be exported without obtaining the export license from the authorities concerned in accordance with the above law.
- No part of this publication may be reproduced or transmitted in any form or by any means, electronic or mechanical, including photocopying and recording, or any information storage or retrieval system, or otherwise, without the prior written permission of SANYO Electric Co., Ltd.
- Any and all information described or contained herein are subject to change without notice due to product/technology improvement, etc. When designing equipment, refer to the "Delivery Specification" for the SANYO product that you intend to use.
- Information (including circuit diagrams and circuit parameters) herein is for example only; it is not guaranteed for volume production. SANYO believes information herein is accurate and reliable, but no guarantees are made or implied regarding its use or any infringements of intellectual property rights or other rights of third parties.

This catalog provides information as of October, 1998. Specifications and information herein are subject to change without notice.