



**SANYO Semiconductors**  
**DATA SHEET**

**LB11850VA** — **Monolithic Digital IC**  
**For Fan Motor**  
**Single-Phase Full-Wave Pre-Driver**  
**with Speed Control Function**

### Overview

The LB11850VA is a single-phase bipolar fan motor driver with speed control function that works with a speed feedback signal. A highly efficient, quiet and low power consumption motor driver circuit, with a high speed accuracy and large variable speed can be implemented by adding a small number of external components.

This pre-driver is optimal for driving large scale fan motors (with large air volume and large current) such as those used in servers and consumer products.

### Functions and features

- Pre-driver for single-phase full-wave drive
  - PMOS-NMOS is used as an external power TR, enabling high-efficiency and low-power-consumption drive by means of the low-saturation output and single-phase full-wave drive.
- On-chip speed control circuit
  - The speed control (closed loop control) using a speed feedback signal makes it possible to achieve higher speed accuracy and lower speed fluctuations when supply voltage fluctuates or load fluctuates, compared with an open-loop control system. Separately excited upper direct PWM control method is used as the variable-speed control system.
- External PWM input or analog voltage input enabling variable speed control
  - The speed control input signal is compatible with PWM duty ratio or analog voltages.
- On-chip soft start circuit
- Lowest speed setting pin
  - The lowest speed can be set with the external resistor.
- Current limiter circuit incorporated
  - Chopper type current limit at start or lock.
- Reactive current cut circuit incorporated
  - Reactive current before phase change is cut to enable silent and low-consumption drive.
- Constraint protection and automatic reset functions incorporated
- FG (speed detection), RD (lock detection) output
- Constant-voltage output pin for hall bias

■ Any and all SANYO Semiconductor Co.,Ltd. products described or contained herein are, with regard to "standard application", intended for the use as general electronics equipment (home appliances, AV equipment, communication device, office equipment, industrial equipment etc.). The products mentioned herein shall not be intended for use for any "special application" (medical equipment whose purpose is to sustain life, aerospace instrument, nuclear control device, burning appliances, transportation machine, traffic signal system, safety equipment etc.) that shall require extremely high level of reliability and can directly threaten human lives in case of failure or malfunction of the product or may cause harm to human bodies, nor shall they grant any guarantee thereof. If you should intend to use our products for applications outside the standard applications of our customer who is considering such use and/or outside the scope of our intended standard applications, please consult with us prior to the intended use. If there is no consultation or inquiry before the intended use, our customer shall be solely responsible for the use.

■ Specifications of any and all SANYO Semiconductor Co.,Ltd. products described or contained herein stipulate the performance, characteristics, and functions of the described products in the independent state, and are not guarantees of the performance, characteristics, and functions of the described products as mounted in the customer's products or equipment. To verify symptoms and states that cannot be evaluated in an independent device, the customer should always evaluate and test devices mounted in the customer's products or equipment.

**SANYO Semiconductor Co., Ltd.**

TOKYO OFFICE Tokyo Bldg., 1-10, 1 Chome, Ueno, Taito-ku, TOKYO, 110-8534 JAPAN

# LB11850VA

## Specifications

### Absolute Maximum Ratings at $T_a = 25^\circ\text{C}$

Parameter	Symbol	Conditions	Ratings	Unit
$V_{CC}$ maximum supply voltage	$V_{CC\text{ max}}$		18	V
OUTN pin maximum output current	$I_{OUTN\text{ max}}$		20	mA
OUTP pin maximum sink current	$I_{OUTP\text{ max}}$		20	mA
OUT pin output withstand voltage	$V_{OUT\text{ max}}$		18	V
HB maximum output current	HB		10	mA
CTL, C pin withstand voltage	CTL, C max		7	V
CVI, LIM pin withstand voltage	CVI, LIM max		7	V
RD/FD output pin output withstand voltage	FG max		19	V
RD/FG output current	FG max		10	mA
5VREG pin maximum output current	$I_{5VREG\text{ max}}$		10	mA
Allowable power dissipation	$P_d\text{ max}$	Mounted on a specified board *	0.9	W
Operating temperature range	$T_{opr}$		-30 to +95	$^\circ\text{C}$
Storage temperature range	$T_{stg}$		-55 to +150	$^\circ\text{C}$

Note \*1: Mounted on a specified board: 114.3mm×76.1mm×1.6mm, glass epoxy.

Note \*2:  $T_j\text{ max} = 150^\circ\text{C}$ . Use the device in a condition that the chip temperature does not exceed  $T_j = 150^\circ\text{C}$  during operation.

### Recommended Operating Ranges at $T_a = 25^\circ\text{C}$

Parameter	Symbol	Conditions	Ratings	Unit
$V_{CC}$ supply voltage 1	$V_{CC1}$	$V_{CC}$ pin	5.5 to 16	V
$V_{CC}$ supply voltage 2	$V_{CC2}$	When $V_{CC}$ -5VREG shorted	4.5 to 5.5	V
CTL input voltage range	VCTL		0 to 5VREG	V
LIM input voltage range	VLIM		0 to 5VREG	V
VCI input voltage range	VCVI		0 to 5VREG	V
Hall input common phase input voltage range	VICM		0.2 to 3	V

### Electrical Characteristics at $T_a = 25^\circ\text{C}$ , $V_{CC} = 12\text{V}$ , unless otherwise specified

Parameter	Symbol	Conditions	Ratings			unit
			min	typ	max	
Circuit current	$I_{CC1}$	During drive		12	15	mA
	$I_{CC2}$	During lock protection		12	15	mA
5VREG voltage	5VREG	$I_{5VREG} = 5\text{mA}$	4.8	5.0	5.2	V
HB voltage	VHB	$I_{HB} = 5\text{mA}$	1.05	1.20	1.35	V
Current limiter voltage	VLIM		190	210	230	mV
CPWM pin H level voltage	VCRH		2.8	3.0	3.2	V
CPWM pin L level voltage	VCRL		0.9	1.1	1.3	V
CPWM pin charge current	ICPWM1	$V_{CPWM} = 0.5\text{V}$	24	30	36	$\mu\text{A}$
CPWM pin discharge current	ICPWM2	$V_{CPWM} = 3.5\text{V}$	21	27	33	$\mu\text{A}$
CPWM oscillation frequency	FPWM	$C = 220\text{pF}$		30		kHz
CT pin H level voltage	VCTH		2.8	3.0	3.2	V
CT pin L level voltage	VCTL		0.9	1.1	1.3	V
CT pin charge current	ICT1	$V_{CT} = 2\text{V}$	1.6	2.0	2.5	$\mu\text{A}$
CT pin discharge current	ICT2	$V_{CT} = 2\text{V}$	0.16	0.20	0.25	$\mu\text{A}$
CT pin charge/discharge current ratio	RCT	$ICT1/ICT2$	8	10	12	times
OUTN pin output H voltage	VONH	$I_O = 10\text{mA}$		$V_{CC}-0.85$	$V_{CC}-1.0$	V
OUTN pin output L voltage	VONL	$I_O = 10\text{mA}$		0.9	1.0	V
OUTP pin output L voltage	VOPL	$I_O = 10\text{mA}$		0.5	0.65	V

Continued on next page.

# LB11850VA

Continued from preceding page.

Parameter	Symbol	Conditions	Ratings			unit
			min	typ	max	
Hall input sensitivity	VHN	IN <sup>+</sup> , IN <sup>-</sup> difference voltage (including offset and hysteresis)		±15	±25	mV
FG output L voltage	VFGL	IFG = 5mA		0.15	0.30	μA
FG pin leak current	IFGL	VFG = 19V			30	μA
RD output L voltage	VRDL	IRD = 5mA		0.15	0.30	V
RD pin leak current	IRDL	VRD = 19V			30	μA
EO pin output H voltage	VEOH	IEO1 = -0.2mA	VREG-1.2	VREG-0.8		V
EO pin output L voltage	VEOL	IEO1 = 0.2mA		0.8	1.1	V
RC pin output H voltage	VRCH		3.2	3.45	3.7	V
RC pin output L voltage	VRCL		0.7	0.8	1.05	V
RC pin clamp voltage	VRCLP		1.3	1.5	1.7	V
CTL pin input H voltage	VCTLH		2.0		VREG	V
CTL pin input L voltage	VCTLL		0		1.0	V
CTL pin input open voltage	VCTLO		VREG-0.5		VREG	V
CTL pin H input H current	ICTLH	VFGIN = 5VREG	-10	0	10	μA
CTL pin L input L current	ICTLL	VFGIN = 0V	-120	-90		μA
C pin output H voltage	VCH		VREG-0.3	VREG-0.1		V
C pin output L voltage	VCL		1.8	2.0	2.2	V
LIM pin input bias current	IBLIM		-1		1	μA
LIM pin common phase input voltage range	VILIM		2.0		VREG	V
SOFT pin charge current	ICSOFT		1.0	1.3	1.6	μA
SOFT pin operating voltage range	VISOFT		2.0		VREG	V
CVI pin input bias current	IB(VCI)		-1		2	μA
CVI pin common phase input voltage range	VIVCI		2.0		VREG	V
CVO pin output H level voltage	V <sub>OH</sub> (VCO)		VREG-0.35	VREG-0.2		V
Output L level voltage	V <sub>OL</sub> (VCO)		1.8	2.0	2.2	V

## Package Dimensions

unit : mm (typ)

3287

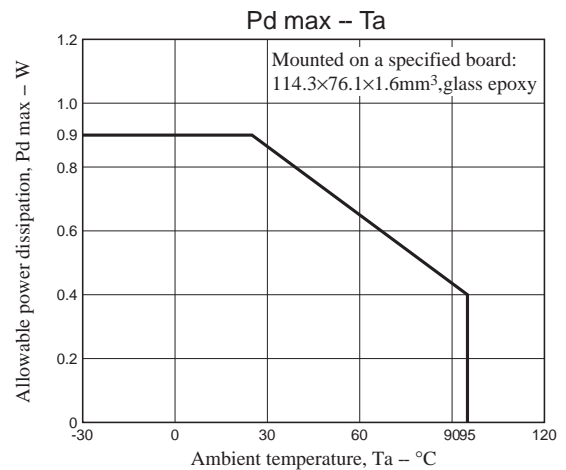
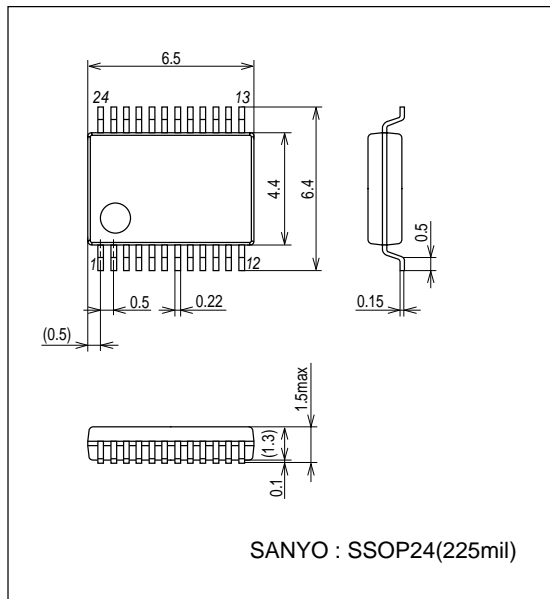

# LB11850VA

## Pin Assignment

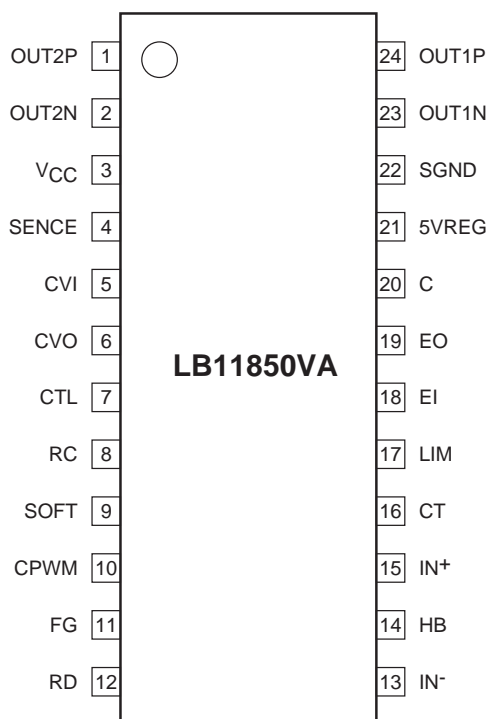

Top view

## Truth Table

Lock protection CPWM = H

IN <sup>-</sup>	IN <sup>+</sup>	CT	OUT1P	OUT1N	OUT2P	OUT2N	FG	Mode
H	L	L	L	L	OFF	H	L	OUT1→2 drive
L	H		OFF	H	L	L	OFF	OUT2→1 drive
H	L	H	OFF	L	OFF	H	L	Lock protection
L	H		OFF	H	OFF	L	OFF	

Speed control CT = L

EO	CPWM	IN <sup>-</sup>	IN <sup>+</sup>	OUT1P	OUT1N	OUT2P	OUT2N	Mode
L	H	H	L	L	L	OFF	H	OUT1→2 drive
		L	H	OFF	H	L	L	OUT2→1 drive
H	L	H	L	OFF	L	OFF	H	Regeneration mode
		L	H	OFF	H	OFF	L	

LB11850VA

Block Diagram

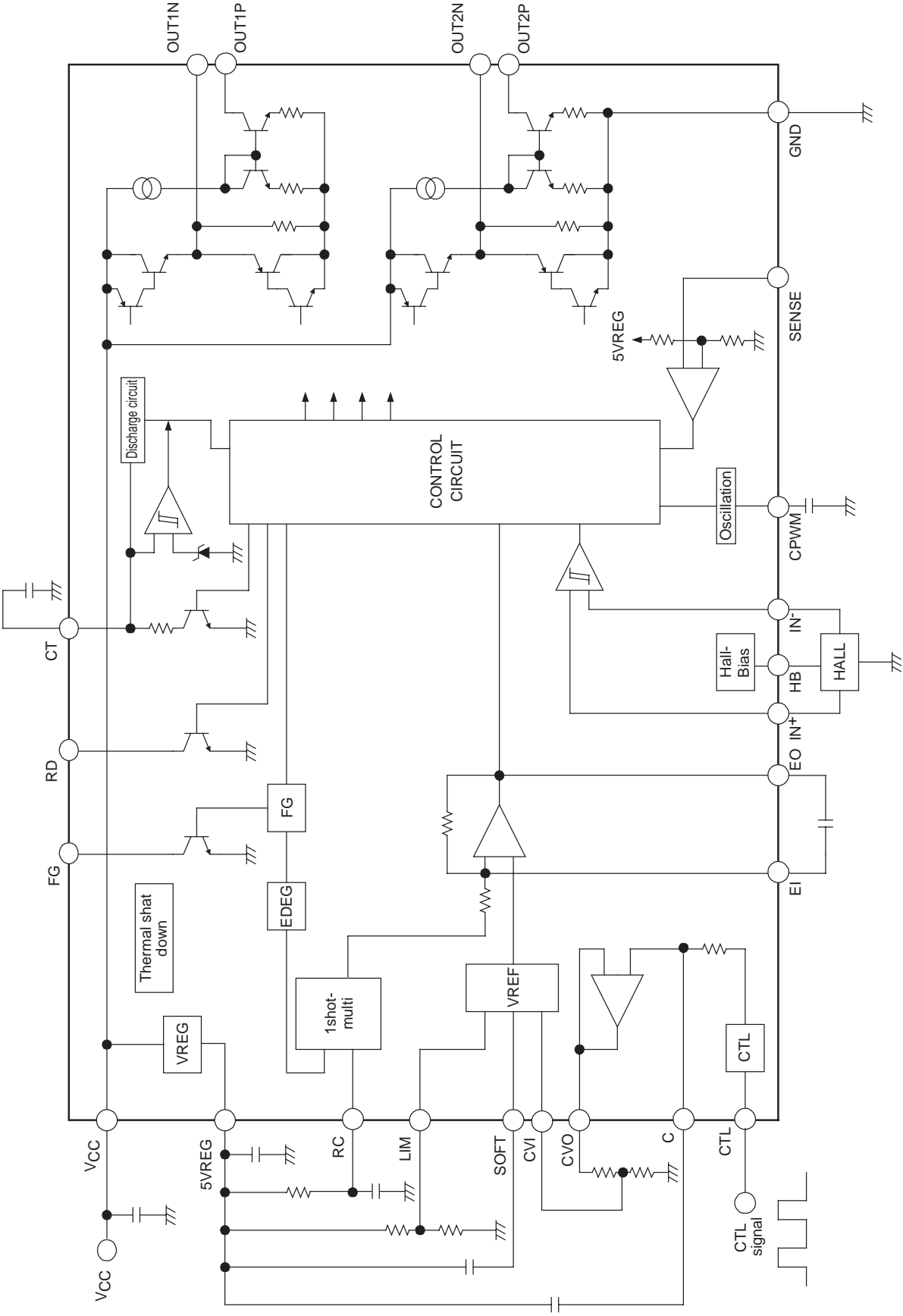

ILB01797

# LB11850VA

## Sample Application Circuit

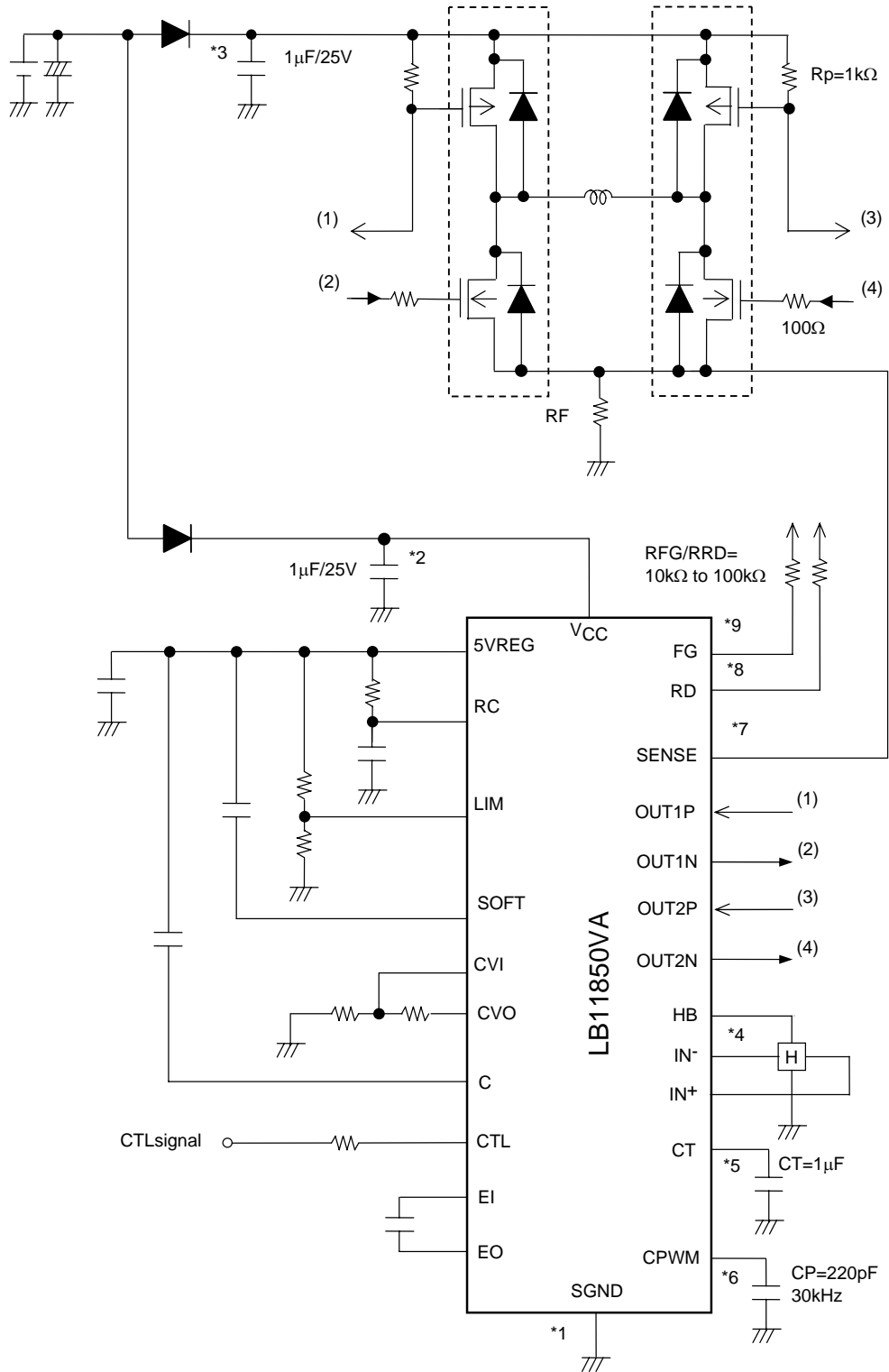

## Description of Pre-driver Block

- \*1: <Power supply-GND wiring>  
SGND is connected to the control circuit power supply system.
  
- \*2: <Power stabilization capacitor>  
For the signal-side power stabilization capacitor, the capacitance of more than 0.1 $\mu$ F is used.  
Connect the capacitor between V<sub>CC</sub> and GND with the thick pattern and along the shortest route.
  
- \*3: <Power-side power stabilization capacitor>  
For the power-side power stabilization capacitor, the capacitance of more than 0.1 $\mu$ F is used.  
Connect the capacitor between power-side power supply and GND with the thick pattern and along the shortest route.
  
- \*4: <IN<sup>+</sup>, IN<sup>-</sup> pins>  
Hall signal input pins  
Wiring needs to be short to prevent carrying noise. If noise is carried, insert a capacitor between IN<sup>+</sup> and IN<sup>-</sup>. The Hall input circuit is a comparator having a hysteresis of 15mV.  
It has a  $\pm$ 30mV (input signal difference voltage) soft switch zone.  
It is recommended that the Hall input level is 100mV (p-p) at the minimum.
  
- \*5: <CPWM pin>  
This is the pin to connect capacitor for generating the PWM basic frequency  
Use of CP = 220pF produces oscillation at the frequency of 30kHz which serves as the PWM basic frequency.  
Since this pin is also used for the current limiter reset signal, the capacitor must be connected without fail even when no speed control is implemented.
  
- \*6: <CT pin>  
This is the pin to connect capacitor for lock detection  
Constant-current charging and constant-current discharging circuits are incorporated. When the pin voltage becomes 3.0V, the safety lock is applied, and when it lowers to 1.0V, the lock protection is reset.  
Connect this pin to GND when it is not in use (when lock protection is not required).
  
- \*7: <SENSE pin>  
This is the pin for current limiter detection  
When the pin voltage exceeds 0.21V, current limiting is applied, and the low-side regeneration mode is established.  
Connect this pin to GND when it is not in use.
  
- \*8: <RD pin>  
Lock detection pin  
This is the open collector output, which outputs "L" during rotation and "H" at stop. This pin is left open when it is not in use.
  
- \*10: <FG pin>  
Speed detection pin.  
This is the open collector output, which can detect the rotation speed using the FG output according to the phase change. This pin is left open when it is not in use.

**Description of Speed Control Block**

1) Speed control diagram

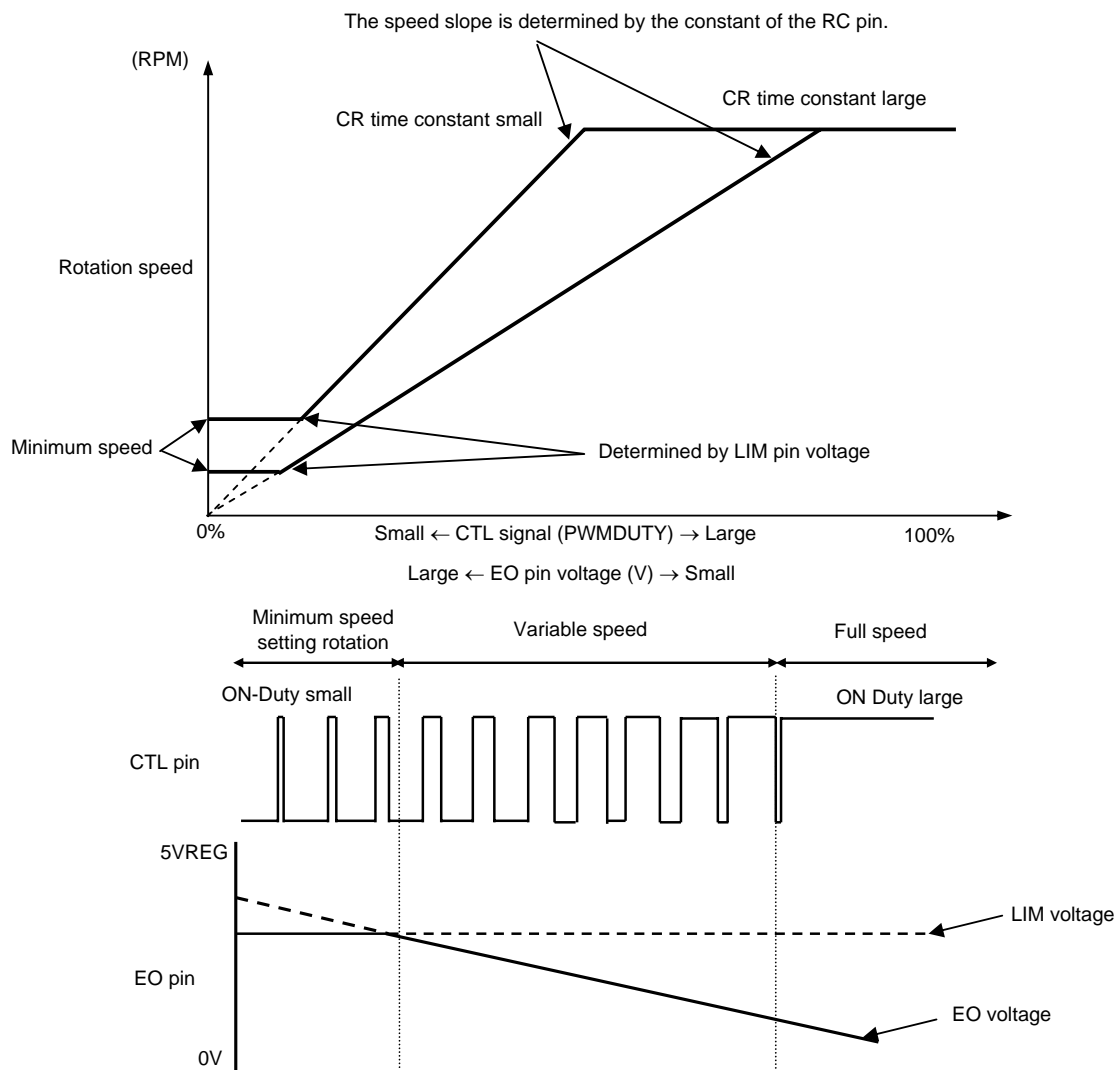

2) Timing at startup (soft start)

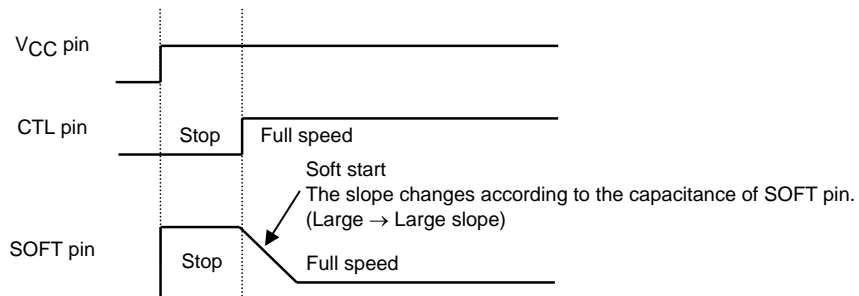



## LB11850VA

### 3) Additional description of operations

The LB11850 forms a feedback loop inside the IC so that the FG period (motor speed) corresponding to the control voltage is established by inputting the duty pulse.

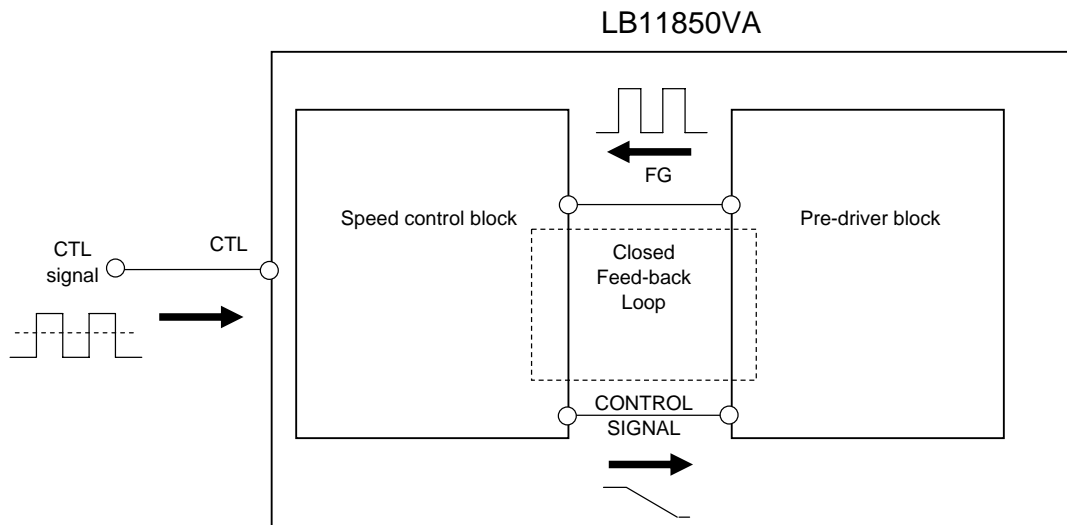

The operation inside the IC is as follows. Pulse signals are created from the edges of the FG signals as shown in the figure below, and a waveform with a pulse width which is determined by the CR time constants and which uses these edges as a reference is generated by a one-shot multivibrator.

These pulse waveforms are integrated and the duty ratio of the pre-driver output is controlled as a control voltage.

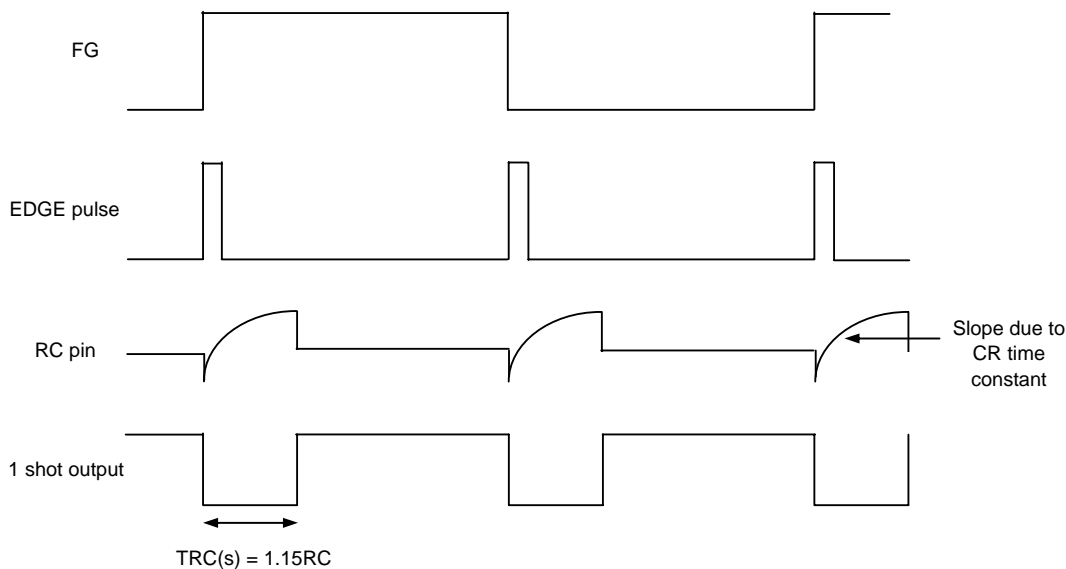

Furthermore, by changing the pulse width as determined by the CR time constant, the VCTL versus speed slope can be changed as shown in the speed control diagram of the previous section.

However, since the pulses used are determined by the CR time constant, the variations in CR are output as-is as the speed control error.

## 4) Procedure for calculating constants

<RC pin>

The slope shown in the speed control diagram is determined by the constant of the RC pin.

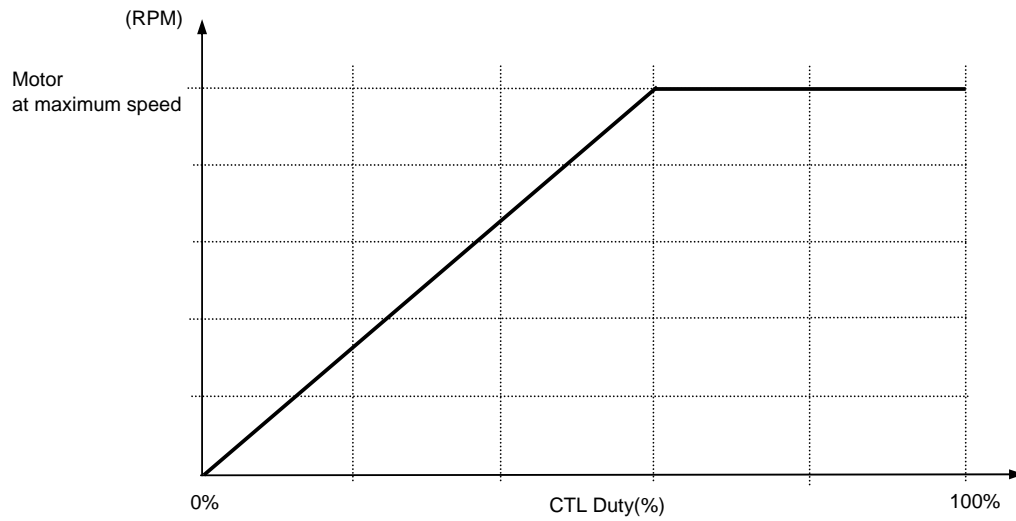

(1) Obtain FG signal frequency  $f_{FG}$  (Hz) of the maximum speed of the motor.

(With FG2 pulses per rotation)

$$f_{FG} \text{ (Hz)} = 2 \text{ rpm}/60 \dots <1>$$

(2) Obtain the time constant which is connected to the RC pin.

(Have "DUTY" (example: 100% = 1.0, 60% = 0.6) serve as the CTL duty ratio at which the maximum speed is to be obtained.)

$$R \times C = \text{DUTY}/(3.3 \times 1.1 \times f_{FG}) \dots <2>$$

(3) Obtain the resistance and capacitance of the capacitor.

Based on the discharge capacity of the RC pin, the capacitance of the capacitor which can be used is 0.01 to 0.015  $\mu\text{F}$ . Therefore, find the appropriate resistance using equation <3> or <4> below from the result of <2> above.

$$R = (R \times C)/0.01 \mu\text{F} \dots <3>$$

$$R = (R \times C)/0.015 \mu\text{F} \dots <4>$$

The temperature characteristics of the curve are determined by the temperature characteristics of the capacitor of the RC pin. When temperature-caused fluctuations in the speed are to be minimized, use a capacitor with good temperature characteristics.

<CVO, CVI pins>

These pins determine the position of the slope origin. (When the origin point is at (0%, 0 rpm), CVO and CVI are shorted.)

(1) Movement along the X-axis (resistance divided between CVO and GND)

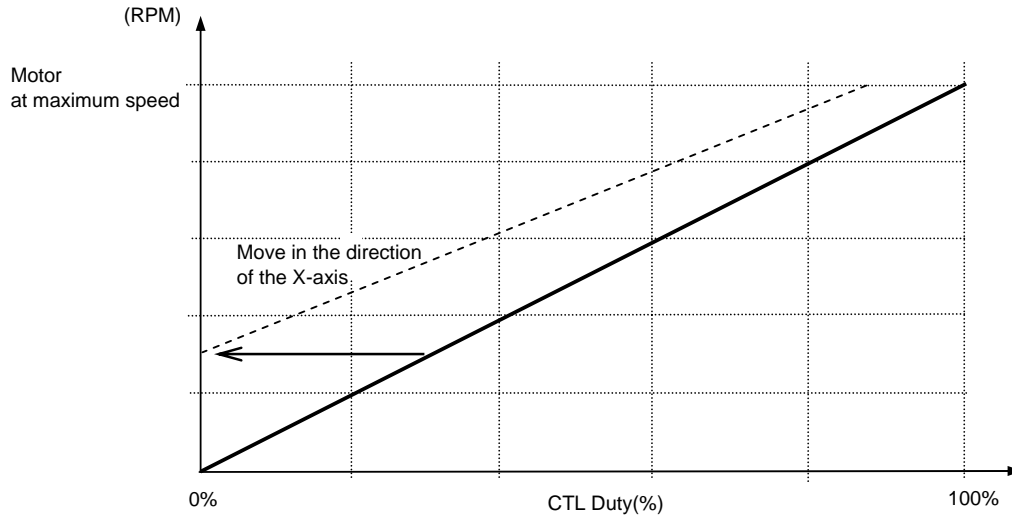

(Example) In the case where the characteristics change from ones with the origin point (0%, 0 rpm) to ones where the speed at a duty ratio of 30% becomes the speed at 0%:

First, obtain the input voltage of the CVI pin required at 0%.

$$CVI = 5 - (3 \times \text{duty ratio}) = 5 - (3 \times 0.3) = 5 - 0.9 = 4.1V$$

Next, obtain the resistances at which the voltage becomes 4.1V by dividing the resistance between CVO and GND when CVO is 5V. The ratio of CVO-CVI: CVI-GND is 0.9V: 4.1V = 1: 4.5.

Based on the above, the resistance is 20kΩ between CVO and CVI and 91kΩ between CVI and GND.

Furthermore, the slope changes. (In the case of the example given, since the resistance ratio is 1: 4.5, the slope is now  $4.5/5.5 = 0.8$  times what it was originally.)

If necessary, change the resistance of the RC pin, and adjust the slope.

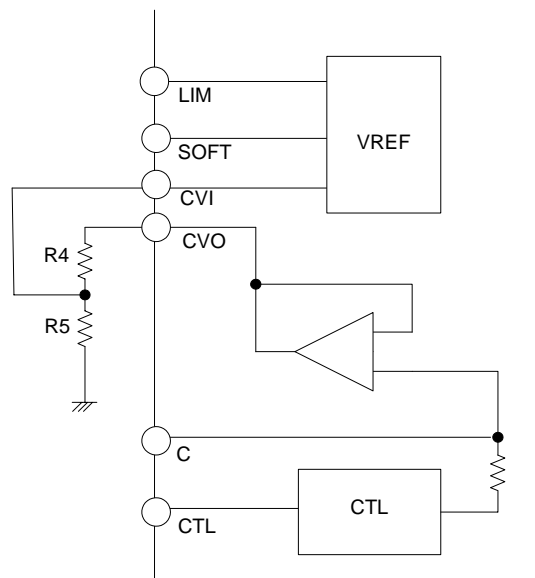

## LB11850VA

(2) Movement along the Y-axis (resistance divided between CVO and V<sub>CC</sub>)

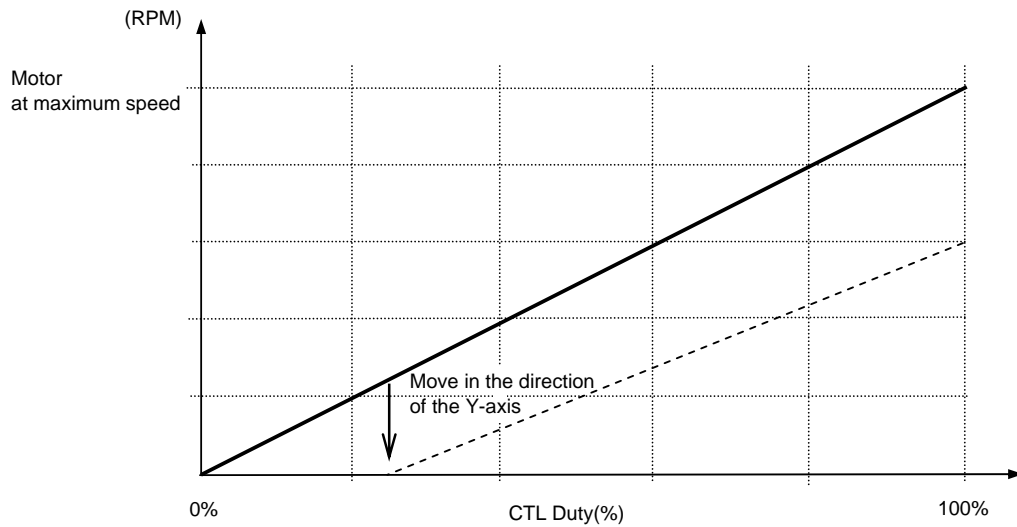

(Example) In the case where the characteristics change from ones with the origin point (0%, 0 rpm) to ones where the speed at a duty ratio of 25% becomes 0 rpm:

First, obtain the CVO pin voltage required for the CVI voltage to be 5V at 25%.

$$CVO = 5 - (3 \times \text{duty ratio}) = 5 - (3 \times 0.25) = 5 - 0.75 = 4.25V$$

With CVO = 4.25V, find the resistances at which CVI = 5V.

The ratio of CVO-CVI: CVI-GND is 0.75V: 7V = 1: 9.3

Based on the above, the resistance is 20kΩ between CVO and CVI and 180kΩ between CVI and V<sub>CC</sub>.

(Due to the current capacity of the CVO pin, the total resistance must be set to 100kΩ or more.)

Furthermore, the slope changes. (In the case of the example given, since the resistance ratio is 1: 9.3, the slope is now 9.3/10.3 = 0.9 times what it was originally.)

If necessary, change the resistance of the RC pin, and adjust the slope.

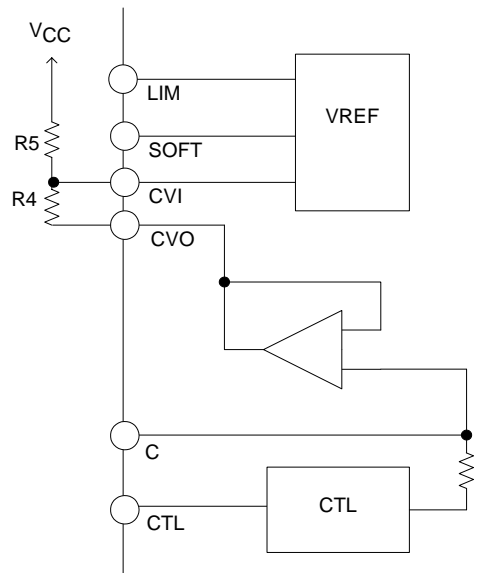

## <LIM pin>

The minimum speed is determined by the voltage of the LIM pin.

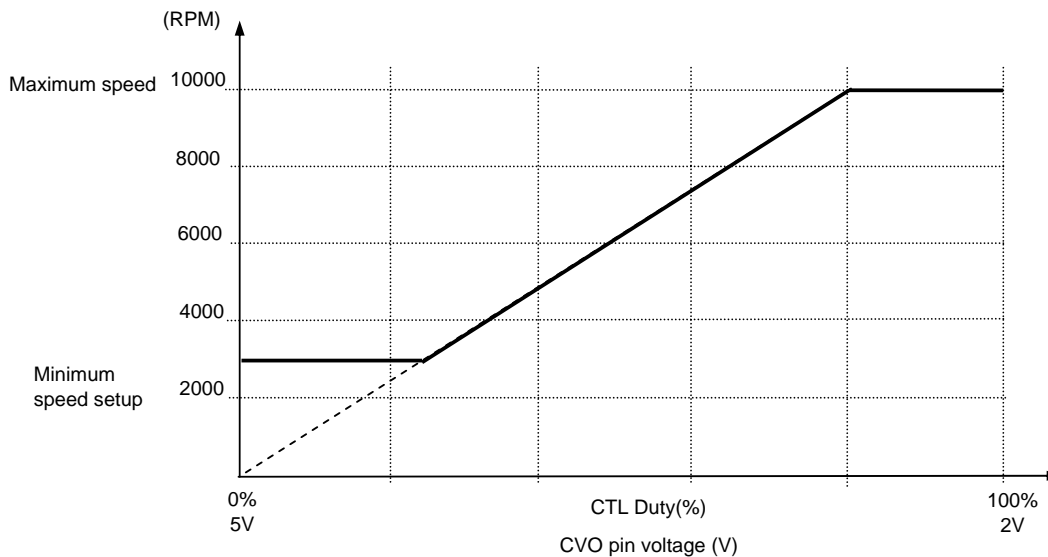

- (1) Obtain the ratio of the minimum speed required to the maximum speed.

$$Ra = \text{Minimum speed}/\text{maximum speed} \dots <1>$$

In the example shown in the figure above,  $Ra = \text{minimum speed}/\text{maximum speed} = 3000/10000 = 0.3$ .

- (2) Obtain the product of the duty ratio at which the maximum speed is obtained and the value in equation <1>.

$$Ca = \text{Duty ratio at maximum speed} \times Ra \dots <2>$$

In this example,  $Ca = \text{duty ratio at maximum speed} \times Ra = 0.8 \times 0.3 = 0.24$ .

- (3) Obtain the required LIM pin voltage.

$$LIM = 5 - (3 \times Ca) \dots <3>$$

In this example,  $LIM = 5 - (3 \times Ca) = 5 - (3 \times 0.24) \approx 4.3V$ .

- (4) Divide the resistance of 5VREG, and generate the LIM voltage.

In this example, the voltage is 4.3V so the resistance ratio is 1: 6.

The resistance is 10k $\Omega$  between 5VREG and LIM and 62k $\Omega$  between LIM and GND.

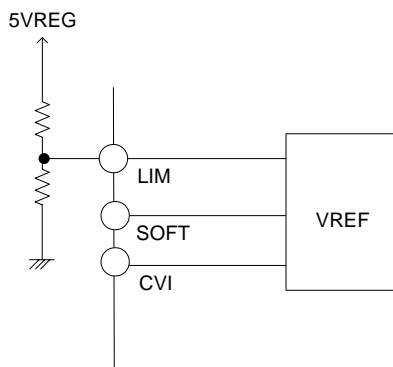

## <C pin>

In order to connect a capacitor capable of smoothing the pin voltage to the C pin, the correlation given in the following equation must be satisfied when  $f$  (Hz) serves as the input signal frequency of the CTL pin. (R is contained inside the IC, and is  $180\text{k}\Omega$  (typ.).)

$$1/f = t < CR$$

The higher the capacitance of the capacitor is, the slower the response to changes in the input signal is.

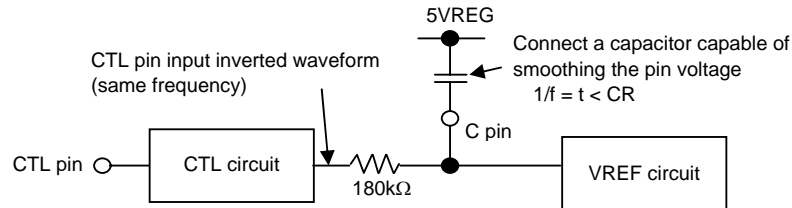

- SANYO Semiconductor Co.,Ltd. assumes no responsibility for equipment failures that result from using products at values that exceed, even momentarily, rated values (such as maximum ratings, operating condition ranges, or other parameters) listed in products specifications of any and all SANYO Semiconductor Co.,Ltd. products described or contained herein.
- SANYO Semiconductor Co.,Ltd. strives to supply high-quality high-reliability products, however, any and all semiconductor products fail or malfunction with some probability. It is possible that these probabilistic failures or malfunction could give rise to accidents or events that could endanger human lives, trouble that could give rise to smoke or fire, or accidents that could cause damage to other property. When designing equipment, adopt safety measures so that these kinds of accidents or events cannot occur. Such measures include but are not limited to protective circuits and error prevention circuits for safe design, redundant design, and structural design.
- In the event that any or all SANYO Semiconductor Co.,Ltd. products described or contained herein are controlled under any of applicable local export control laws and regulations, such products may require the export license from the authorities concerned in accordance with the above law.
- No part of this publication may be reproduced or transmitted in any form or by any means, electronic or mechanical, including photocopying and recording, or any information storage or retrieval system, or otherwise, without the prior written consent of SANYO Semiconductor Co.,Ltd.
- Any and all information described or contained herein are subject to change without notice due to product/technology improvement, etc. When designing equipment, refer to the "Delivery Specification" for the SANYO Semiconductor Co.,Ltd. product that you intend to use.
- Information (including circuit diagrams and circuit parameters) herein is for example only; it is not guaranteed for volume production.
- Upon using the technical information or products described herein, neither warranty nor license shall be granted with regard to intellectual property rights or any other rights of SANYO Semiconductor Co.,Ltd. or any third party. SANYO Semiconductor Co.,Ltd. shall not be liable for any claim or suits with regard to a third party's intellectual property rights which has resulted from the use of the technical information and products mentioned above.

This catalog provides information as of March, 2007. Specifications and information herein are subject to change without notice.