



SANYO Semiconductors

DATA SHEET

LB11948T — Monolithic Digital IC PWM Constant Current Control 1-2 Phase Excitation Stepping Motor Driver

Overview

The LB11948T is a low saturation voltage output PWM current control bipolar drive stepping motor driver. It is optimal for use as the driver for the miniature low-voltage stepping motors used in portable electronic equipment such as portable thermal printers.

Features

- PWM current control (external excitation)
- Simultaneous on state prevention function (through current prevention)
- Thermal shutdown circuit
- Noise canceller function
- Low-power mode control pin

Specifications

Absolute Maximum Ratings at $T_a = 25^\circ\text{C}$

Parameter	Symbol	Conditions	Ratings	Unit
VS supply voltage	VS		-0.3 to +18	V
Logic system supply voltage	V_{CC}		-0.3 to +18	V
Peak output current	I_O peak	$t_W \leq 20\mu\text{S}$	0.5	A
Continuous output current	I_O max		0.4	A
Emitter output voltage	VE		1.0	V
Input voltage	V_{IN}		-0.3 to V_{CC}	V
Allowable power dissipation	P_d max	Mounted on the specified PCB*	1.2	W
Operating temperature	T_{opg}		-20 to +85	$^\circ\text{C}$
Storage temperature	T_{stg}		-40 to +150	$^\circ\text{C}$

Note * : Specified PCB : 114.3×76.1×1.6mm

■ Any and all SANYO Semiconductor Co.,Ltd. products described or contained herein are, with regard to "standard application", intended for the use as general electronics equipment (home appliances, AV equipment, communication device, office equipment, industrial equipment etc.). The products mentioned herein shall not be intended for use for any "special application" (medical equipment whose purpose is to sustain life, aerospace instrument, nuclear control device, burning appliances, transportation machine, traffic signal system, safety equipment etc.) that shall require extremely high level of reliability and can directly threaten human lives in case of failure or malfunction of the product or may cause harm to human bodies, nor shall they grant any guarantee thereof. If you should intend to use our products for applications outside the standard applications of our customer who is considering such use and/or outside the scope of our intended standard applications, please consult with us prior to the intended use. If there is no consultation or inquiry before the intended use, our customer shall be solely responsible for the use.

■ Specifications of any and all SANYO Semiconductor Co.,Ltd. products described or contained herein stipulate the performance, characteristics, and functions of the described products in the independent state, and are not guarantees of the performance, characteristics, and functions of the described products as mounted in the customer's products or equipment. To verify symptoms and states that cannot be evaluated in an independent device, the customer should always evaluate and test devices mounted in the customer's products or equipment.

SANYO Semiconductor Co., Ltd.

TOKYO OFFICE Tokyo Bldg., 1-10, 1 Chome, Ueno, Taito-ku, TOKYO, 110-8534 JAPAN

D2607 MS PC 20060201-S00001/N2206/D1504TN(OT)/81004TN(OT) No.7947-1/13

LB11948T

Recommended Operating Conditions at $T_a = 25^\circ\text{C}$

Parameter	Symbol	Conditions	Ratings	Unit
VS supply voltage	VS		3.0 to 15	V
V _{CC} supply voltage	V _{CC}		3.0 to 15	V
Reference voltage	VREF	V _{CC} ≤ 4V	0.0 to 1.0	V
		V _{CC} > 4V	0.0 to 1.5	V

Electrical Characteristics $T_a = 25^\circ\text{C}$, VS = V_{CC} = 5V, VREF = 0.3V

Parameter	Symbol	Conditions	Ratings			Unit
			min	typ	max	
[Output Block]						
VS system supply current	I _{VS} OFF	PH1 = PH2 = 0V, EN1 = EN2 = 3.0V, ST = 3.0V			5	μA
	I _{VS} ON	PH1 = PH2 = EN1 = EN2 = 0V, ST = 3.0V	28	40	52	mA
	I _{VS} wt	PH1 = PH2 = EN1 = EN2 = ST = 0V			1	μA
Output saturation voltage 1	V _O (sat) 1	I _O = +0.2A (source)		0.2	0.4	V
Output saturation voltage 2	V _O (sat) 2	I _O = +0.4A (source)		0.3	0.5	V
Output saturation voltage 3	V _O (sat) 3	I _O = -0.2A (sink)		0.2	0.4	V
Output saturation voltage 4	V _O (sat) 4	I _O = -0.4A (sink)		0.3	0.5	V
Output leakage current	I _{O1} (leak)	V _O = V _{BB} (sink)			50	μA
	I _{O2} (leak)	V _O = 0V (source)	-50			μA
Upper and lower side output diodes						
Forward voltage 1 (upper side)	VF1	I = 400mA	0.9	1.1	1.3	V
Forward voltage 2 (lower side)	VF2	I = 400mA	0.9	1.1	1.3	V
[Logic Block]						
V _{CC} system supply current	I _{CC} OFF	PH1 = PH2 = 0V, EN1 = EN2 = 3.0V, ST = 3.0V	6.5	10	13.5	mA
	I _{CC} ON	PH1 = PH2 = EN1 = EN2 = 0V, ST = 3.0V	7	11	15	mA
	I _{CC} wt	PH1 = PH2 = EN1 = EN2 = ST = 0V			1	μA
Input voltage	V _I on		2.0			V
	V _I off				0.8	V
Input current	I _{IN}	V _{IN} = 5V	70	100	130	μA
Reference voltage : 1V	V1V	I _O = 1mA	0.95	1	1.05	V
Current setting reactive current	IE		-22	-17	-10.5	mA
Reference current	IREF	VREF = 0.3V, VE = 0.3V	-1			μA
CR pin current 1	ICR1	CR = 0.5V	-2			μA
CR pin current 2	ICR2	CR = 3V	1.65	2.2	2.75	mA
Sense voltage 1	VSEN1	VREF = 0.5V	0.475	0.5	0.525	V
Thermal shutdown temperature *	TS	*		170		°C

Note * : Design guarantee value

Truth Table

Input	Channel 1				Channel 2			
	Input		Output		Input		Output	
ST	PHASE1	ENABLE1	OUT1 ⁻	OUT1	PHASE2	ENABLE2	OUT2 ⁻	OUT2
H	L	L	H	L	L	L	H	L
H	H	L	L	H	H	L	L	H
H	*	H	OFF	OFF	*	H	OFF	OFF
L	*	*	OFF	OFF	*	*	OFF	OFF

Note * : Levels shown as an asterisk (*) can be set to be either high or low.

LB11948T

Package Dimensions

unit : mm (typ)

3259

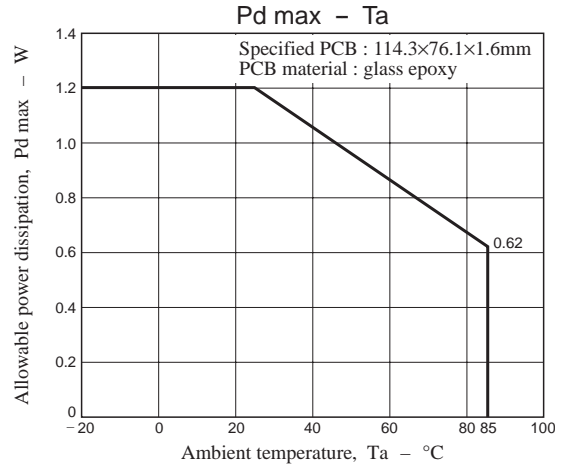
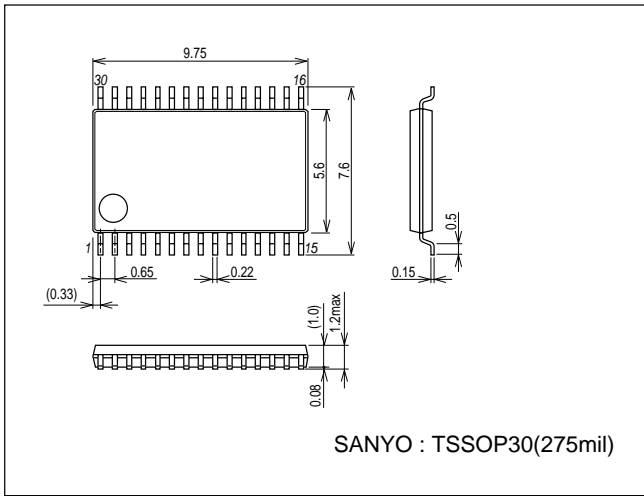

Pin Assignment

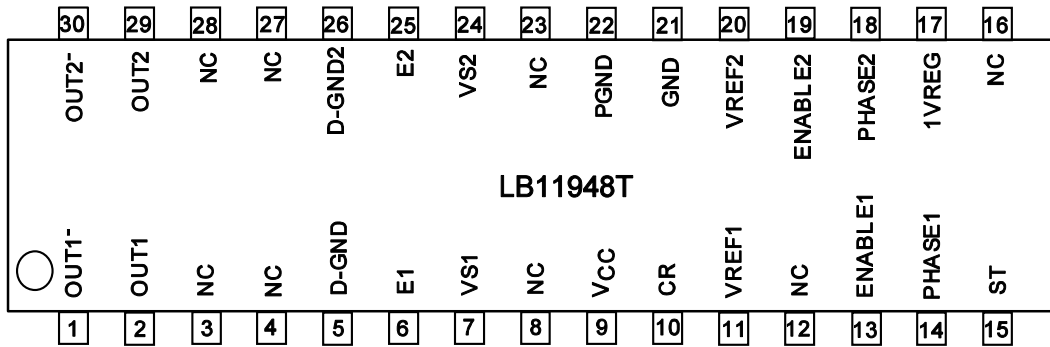

Top view

LB11948T

Pin Functions

Pin No.	Pin Name	Description
1	OUT1 ⁻	Output
2	OUT1	Output
3	NC	Unused
4	NC	Unused
5	D-GND	Lower side internal diode anode connection
6	E1	Constant current control sensing The motor current is set by the value of the sensing resistor R_e connected between the E1 pin and ground. The current is set according to the following equation : $I_O = V_{REF}/R_e$ (A)
7	VS1	VS power supply
8	NC	Unused
9	V _{CC}	V _{CC} power supply
10	CR	RC oscillator connection
11	VREF1	Current setting system reference voltage input VREF1 voltage range : 0 to 0.5V
12	NC	Unused
13	ENABLE1	Output is turned on when ENABLE1 is low, and the output is turned off (operating state) when ENABLE1 is high.
14	PHASE1	Logic level input : phase switching When PHASE1 = high : Output pin states : OUT1 : high, OUT1 ⁻ : low. When PHASE1 = low : Output pin states : OUT1 : low, OUT1 ⁻ : high.
15	ST	Standby mode setting When ST = high : the IC operates in normal operating mode. When ST = low : the IC operates in standby mode. The VS and V _{CC} current drain levels are under 1μA in this mode.
16	NC	Unused
17	1VREG	1V regulator circuit output The LB11948 includes an internal 1V regulator circuit, and this pin is the output from that circuit. The VREF1 and VREF2 reference voltages can be set by voltage dividing the 1V regulator output.
18	PHASE2	Logic level input : phase switching When PHASE2 = high : Output pin states : OUT2 : high, OUT2 ⁻ : low. When PHASE2 = low : Output pin states : OUT2 : low, OUT2 ⁻ : high.
19	ENABLE2	Output is turned on when ENABLE2 is low, and the output is turned off (operating state) when ENABLE2 is high.
20	VREF2	Current setting reference voltage input VREF2 voltage range : 0 to 0.5V
21	GND	Ground (small signal circuit system ground)
22	PGND	Power system ground (high current circuit system ground)
23	NC	Unused
24	VS2	VS power supply
25	E2	Constant current control sensing The motor current is set by the value of the sensing resistor R_e connected between the E2 pin and ground. The current is set according to the following equation : $I_O = V_{REF}/R_e$ (A)
26	D-GND2	Lower side internal diode anode connection
27	NC	Unused
28	NC	Unused
29	OUT2	Output
30	OUT2 ⁻	Output

Block Diagram

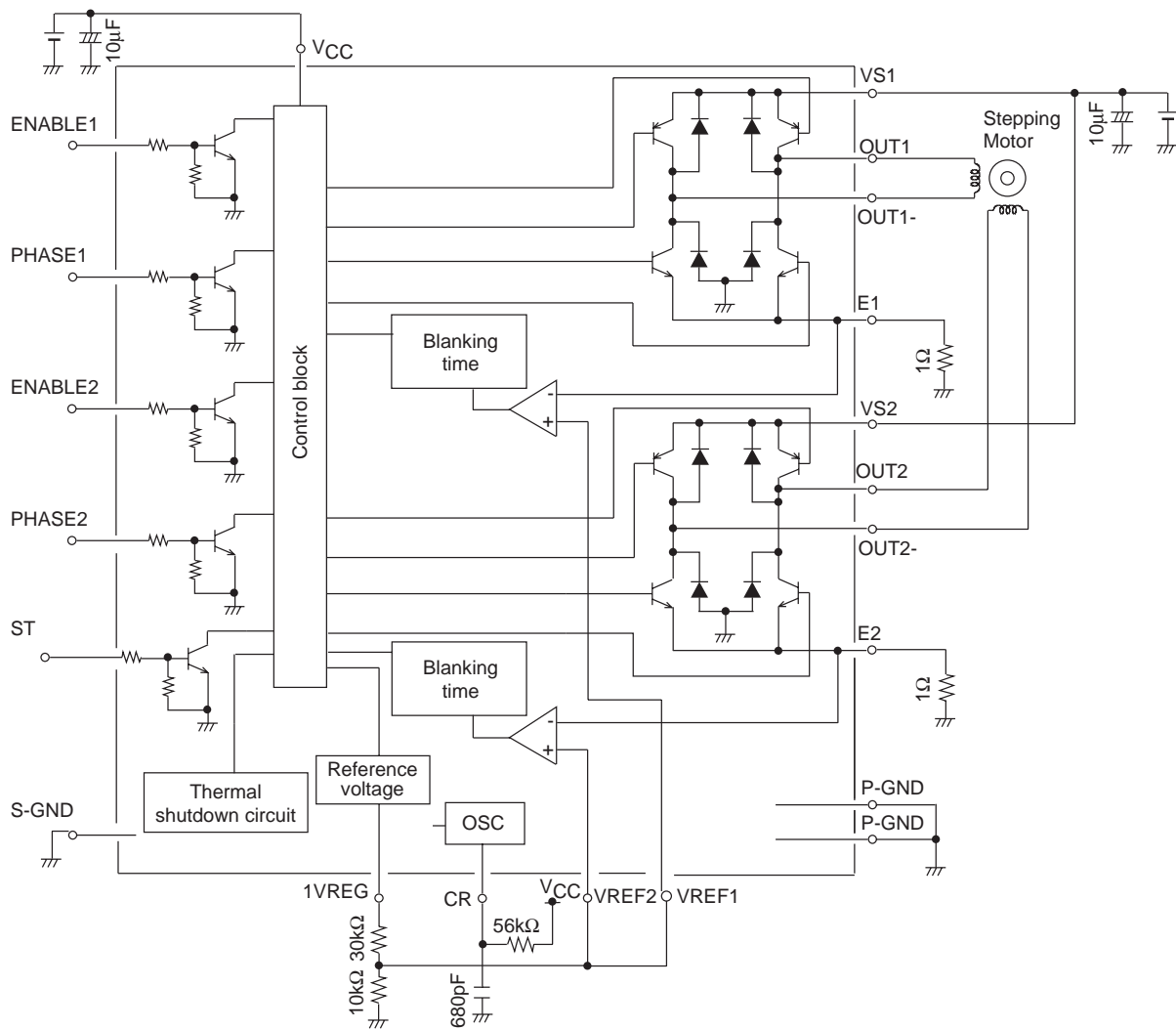

LB11948T

Sample Application Circuit

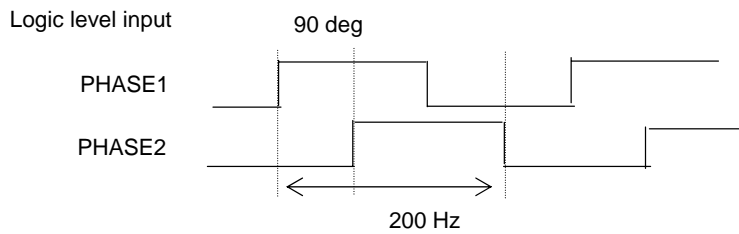
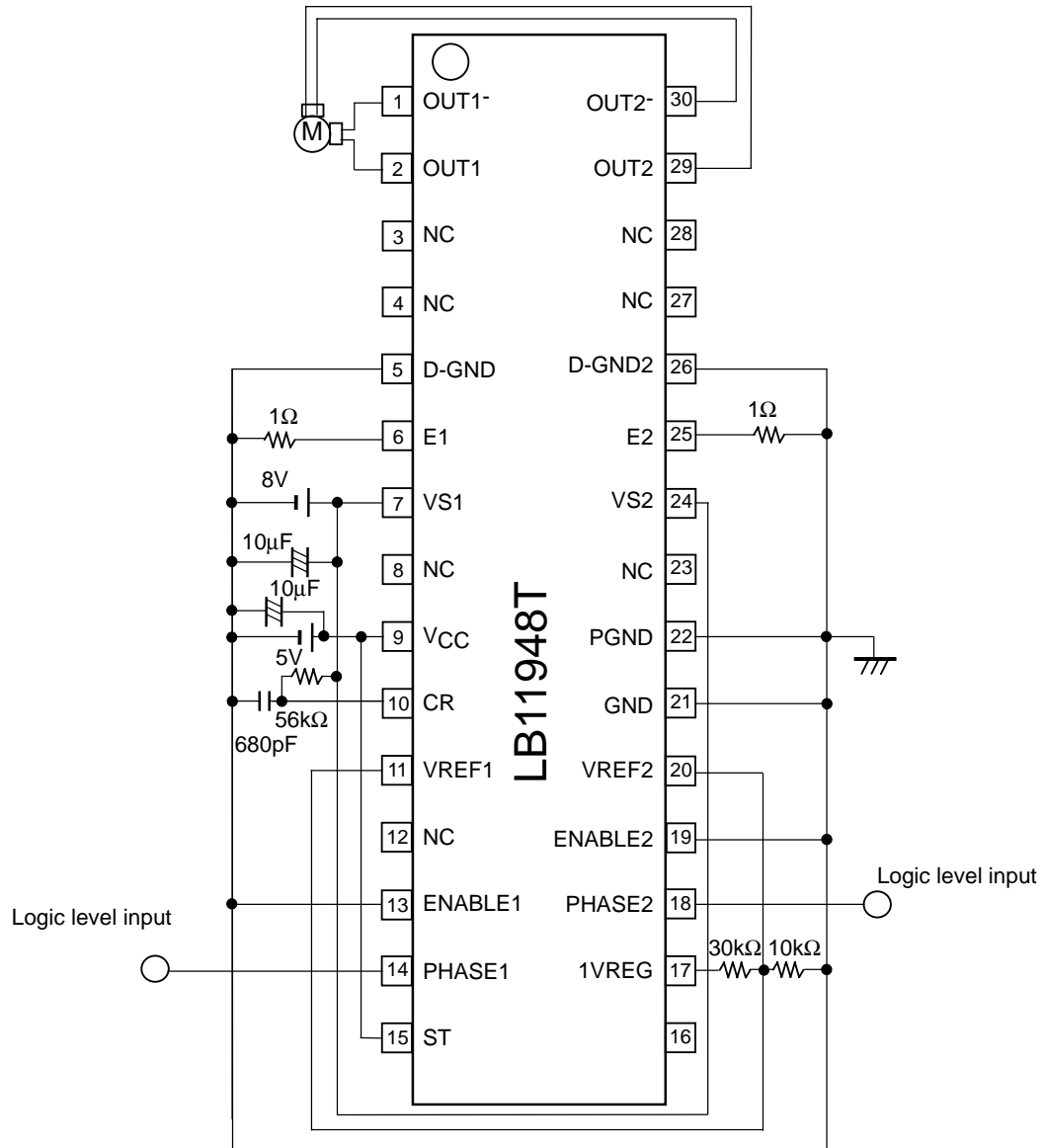

Drive Sequence Table
2 Phase Excitation Drive Sequence

Table 1 Clockwise drive

No.	PHASE1	ENABLE1	OUT1	OUT1'	PHASE2	ENABLE2	OUT2	OUT2'
0	0	0	0	1	0	0	0	1
1	1	0	1	0	0	0	0	1
2	1	0	1	0	1	0	1	0
3	0	0	0	1	1	0	1	0

Table 2 Counterclockwise drive

No.	PHASE1	ENABLE1	OUT1	OUT1'	PHASE2	ENABLE2	OUT2	OUT2'
0	0	0	0	1	1	0	1	0
1	1	0	1	0	1	0	1	0
2	1	0	1	0	0	0	0	1
3	0	0	0	1	0	0	0	1

1-2 Phase Excitation Drive Sequence

Table 3 Clockwise drive

No.	PHASE1	ENABLE1	OUT1	OUT1'	PHASE2	ENABLE2	OUT2	OUT2'
0	0	0	0	1	0	1	OFF	OFF
1	0	0	0	1	0	0	0	1
2	1	1	OFF	OFF	0	0	0	1
3	1	0	1	0	0	0	0	1
4	1	0	1	0	1	1	OFF	OFF
5	1	0	1	0	1	0	1	0
6	0	1	OFF	OFF	1	0	1	0
7	0	0	0	1	1	0	1	0

Table 4 Counterclockwise drive

No.	PHASE1	ENABLE1	OUT1	OUT1'	PHASE2	ENABLE2	OUT2	OUT2'
0	0	0	0	1	1	1	OFF	OFF
1	0	0	0	1	1	0	1	0
2	1	1	OFF	OFF	1	0	1	0
3	1	0	1	0	1	0	1	0
4	1	0	1	0	0	1	OFF	OFF
5	1	0	1	0	0	0	0	1
6	0	1	OFF	OFF	0	0	0	1
7	0	0	0	1	0	0	0	1

2 Phase Excitation Drive Sequence

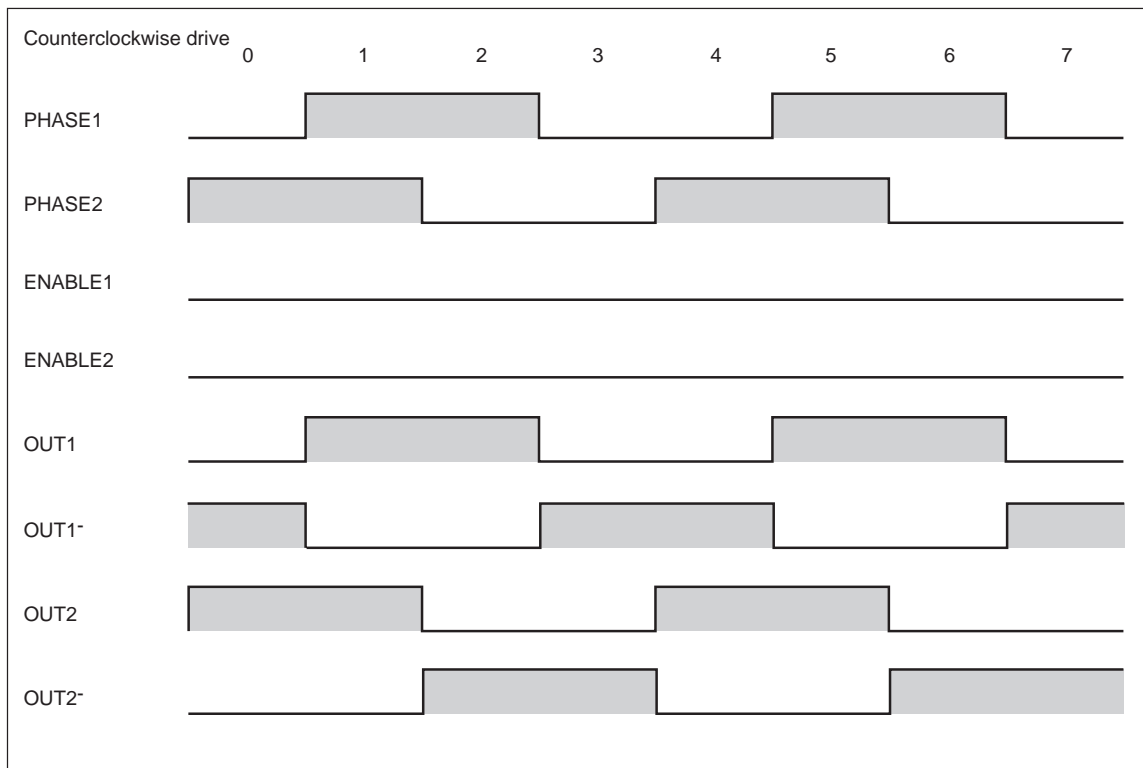
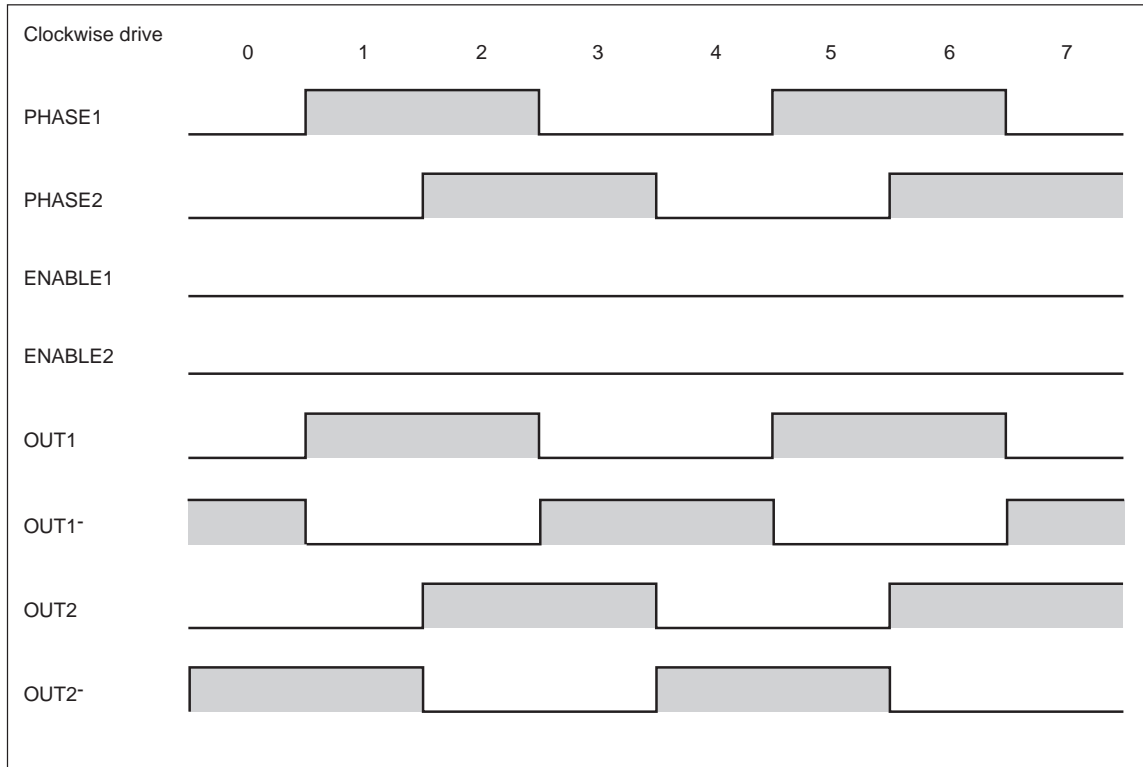

1-2 Phase Excitation Drive Sequence

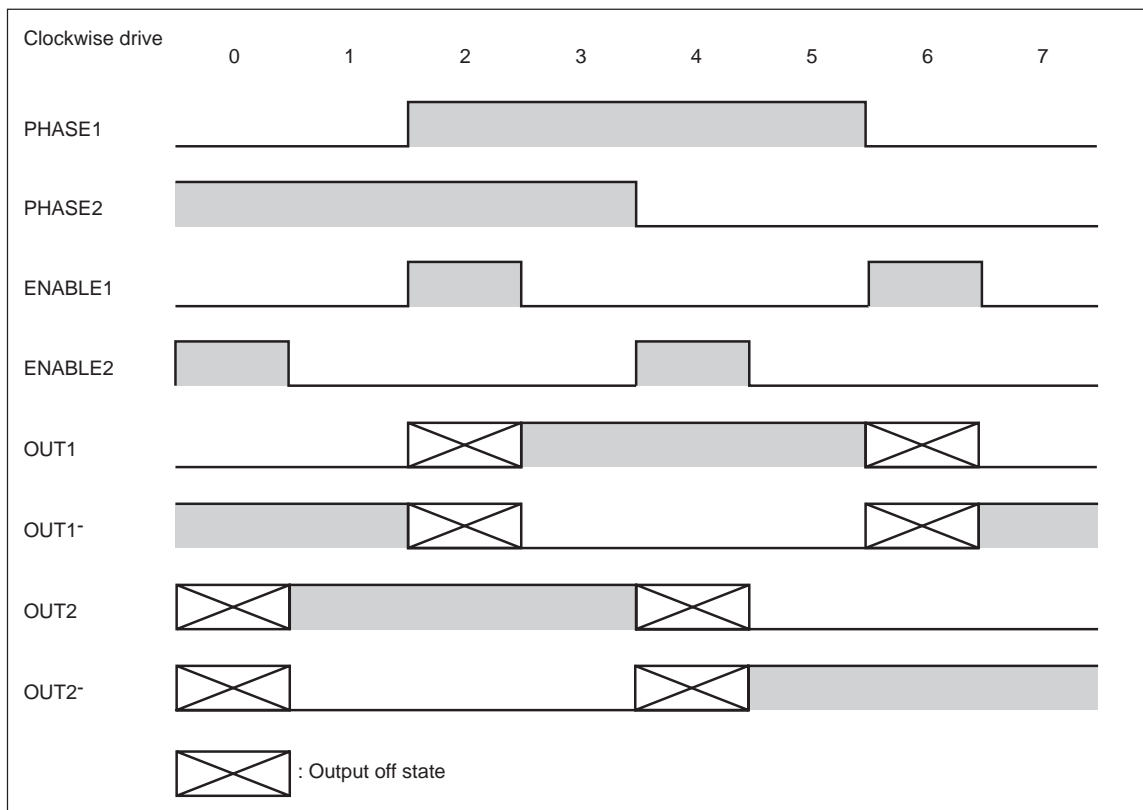
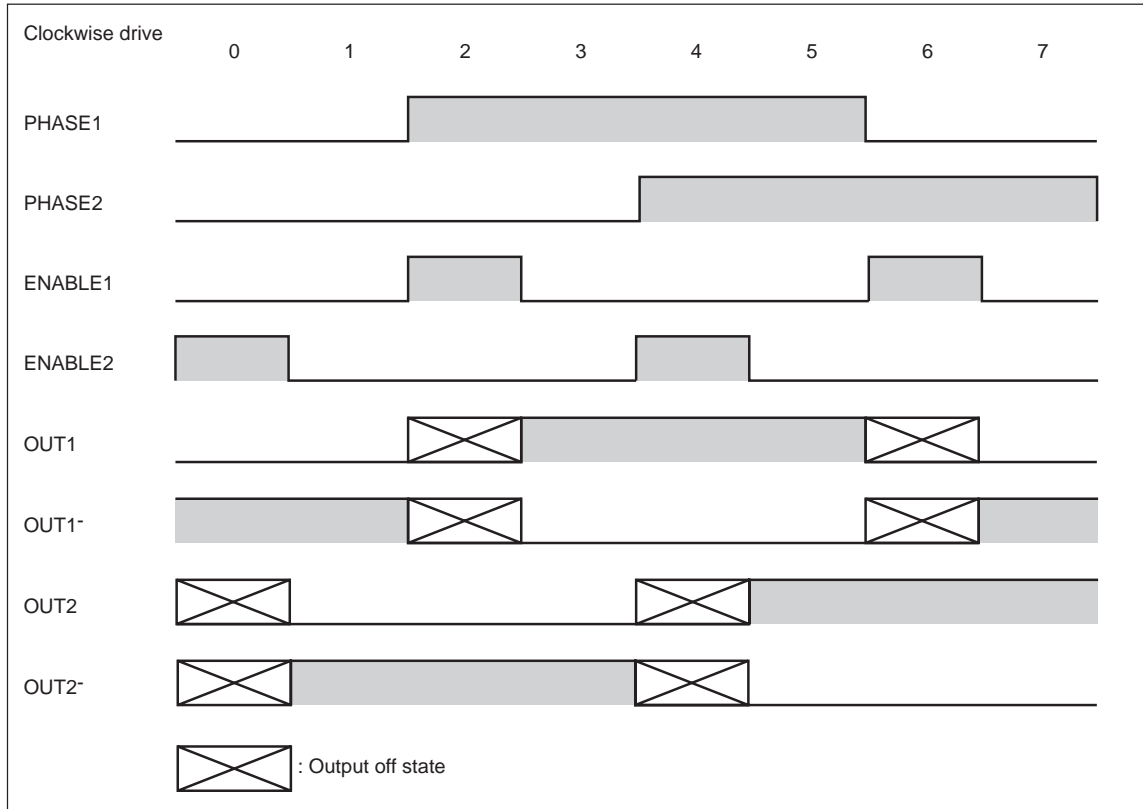

Switching Operation Timing Chart

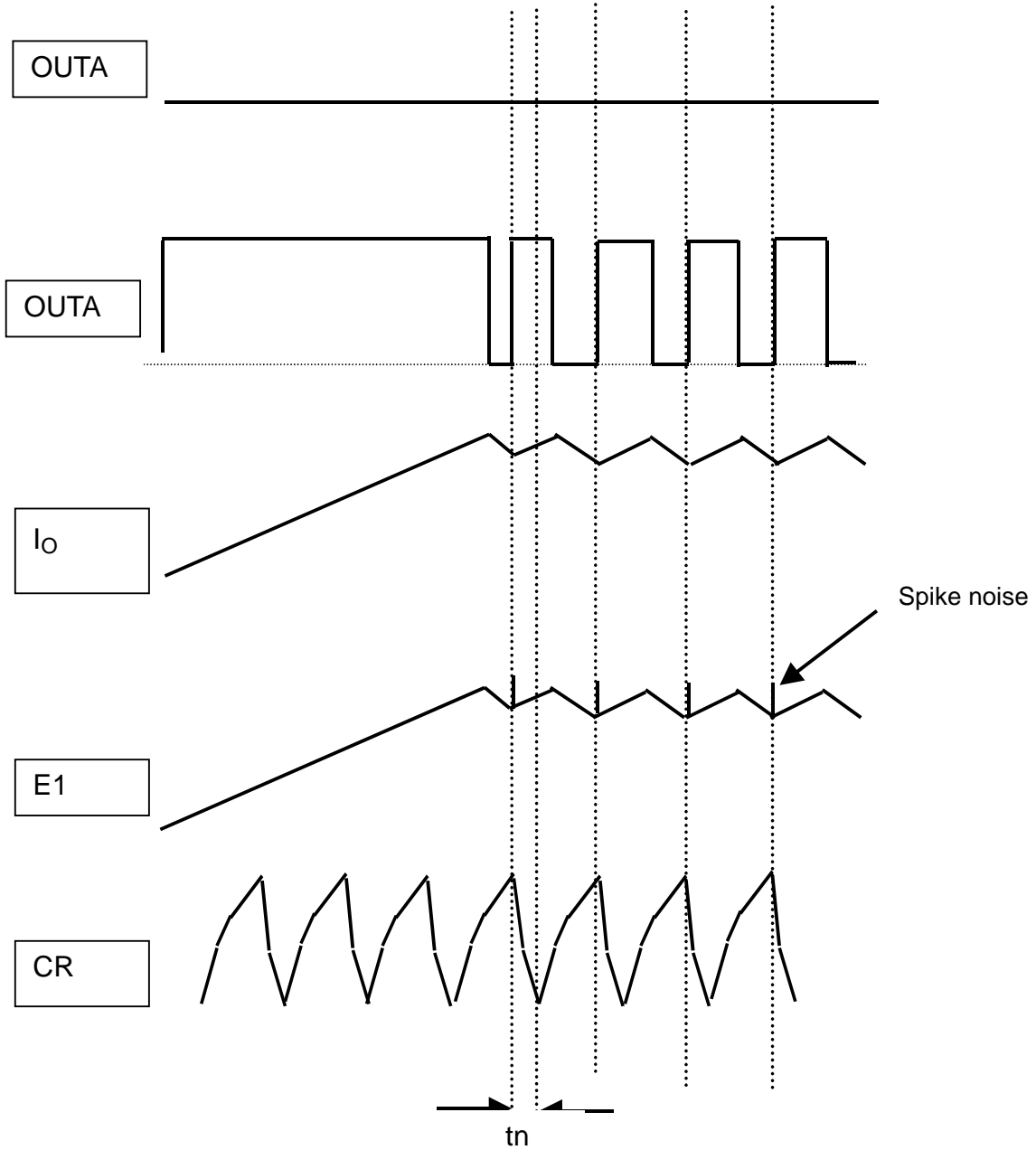

tn: The noise canceller operating time

Usage Notes

(1) Simple Formulas for Determining Resistor and Capacitor Values

The formula for setting the rising time (T1) and the falling time (T2) for the RC oscillator are shown below. (Refer to Fig. 1)

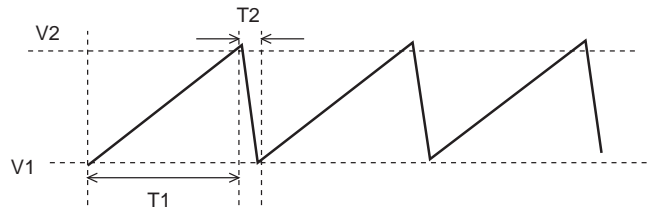

Fig. 1

Formulas

Oscillation period $T = T1 + T2$ (sec)

Threshold voltages $V1 = ((V_{CC} - V_{set1}) \times 10.7k / 48.7k) + V_{set1}$ (V)

$V2 = ((V_{CC} - V_{set2}) \times 42.7k / 80.7k) + V_{set2}$ (V)

V_{set1} : VCE voltage of transistor for internal comparator hysteresis = 0.05V

V_{set2} : VCE voltage of reference resistance switching transistor of oscillation circuit = 0.1V

When charging : $T1 = -C \times R \times \ln \{ (V_{CC} - V2) / (V_{CC} - V1) \}$ (sec)

When discharging : $T2 = -C \times R_{in} \times \ln (V1 / V2)$ (sec)

R_{in} : Internal discharge resistance of the CR pin 1.3k Ω

C : External capacitor

R : External resistor

Oscillation frequency $F_c = 1 / T$ (Hz)

The T2 fall time serves as the noise canceling time (Tn). This time is a forced-on time for the output, and the output is not turned off even when the E pin voltage is higher than the sense voltage that has been preset by VREF.

(2) Constant current settings

The reference voltages of the VREF1 and VREF2 pins can be set by dividing the resistance voltage from the 1V regulator output pin (1VREG).

The output current is set using the VREF reference voltage applied to the VREF1 and VREF2 pins and the Re resistor connected between the E1 and E2 pins and ground. The bias current of the output transistor also flows from the E pins so that the Iout output current flowing to the motor is reduced by an amount equivalent to the bias current. In addition, in controlling the constant current, the voltage is sensed by the E pins (pad area on IC chip) so that the amount equivalent to the wire bonding resistance (rw) from the pad to the package pins is added to the current sensing resistance (Re).

Therefore, the formula for calculating the current setting is as shown below. (Refer to Fig. 2)

$$I_{OUT} = VREF / (Re + rw) - I_{bias} \quad [A]$$

Re : Sensing resistance of resistor connected between E pins and ground

rw : Amount equivalent to wire bonding resistance from pad to pins $rw = 50 - 100m\Omega$

Ibias : Output transistor bias current

The Ibias current corresponds to the current setting reactive current (IE) in the specifications for the electrical characteristics.

Current setting reactive current IE ratings : Min : -22mA Typ : -17mA Max : -10.5mA

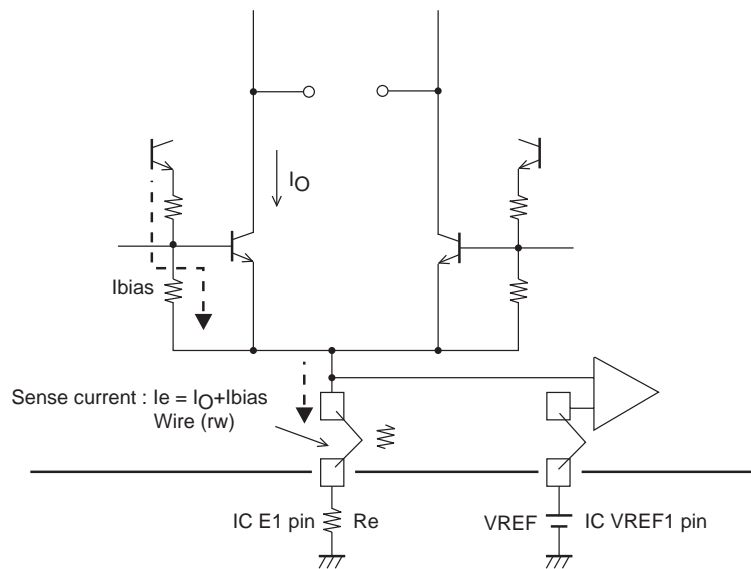

Fig. 2

(3) VREF pins

The VREF pins are the reference voltage input pins for the preset current, so take special care to ensure that they are not affected by noise. If these pins will be affected by noise, connect a capacitor to VREF1 and VREF2 pins.

(4) Notes on the Ground Pins

Since this IC switches large currents, the following notes on ground lines must be observed.

- The PCB pattern lines in areas that handle large currents must be as wide as possible so as to have low impedances, and must be kept as far as possible from the small signal systems.
- The ground terminals on the sensing resistors Re connected to the E pins (E1 and E2) must be connected as close as possible to the IC GND (pin 21), PGND (pin 22), or DGND (pins 5 and 26) pins as possible.
- The capacitors between VCC and ground and between VBB and ground must be as close as possible to the corresponding VCC and VBB pin in the pattern.

- SANYO Semiconductor Co.,Ltd. assumes no responsibility for equipment failures that result from using products at values that exceed, even momentarily, rated values (such as maximum ratings, operating condition ranges, or other parameters) listed in products specifications of any and all SANYO Semiconductor Co.,Ltd. products described or contained herein.
- SANYO Semiconductor Co.,Ltd. strives to supply high-quality high-reliability products, however, any and all semiconductor products fail or malfunction with some probability. It is possible that these probabilistic failures or malfunction could give rise to accidents or events that could endanger human lives, trouble that could give rise to smoke or fire, or accidents that could cause damage to other property. When designing equipment, adopt safety measures so that these kinds of accidents or events cannot occur. Such measures include but are not limited to protective circuits and error prevention circuits for safe design, redundant design, and structural design.
- In the event that any or all SANYO Semiconductor Co.,Ltd. products described or contained herein are controlled under any of applicable local export control laws and regulations, such products may require the export license from the authorities concerned in accordance with the above law.
- No part of this publication may be reproduced or transmitted in any form or by any means, electronic or mechanical, including photocopying and recording, or any information storage or retrieval system, or otherwise, without the prior written consent of SANYO Semiconductor Co.,Ltd.
- Any and all information described or contained herein are subject to change without notice due to product/technology improvement, etc. When designing equipment, refer to the "Delivery Specification" for the SANYO Semiconductor Co.,Ltd. product that you intend to use.
- Information (including circuit diagrams and circuit parameters) herein is for example only; it is not guaranteed for volume production.
- Upon using the technical information or products described herein, neither warranty nor license shall be granted with regard to intellectual property rights or any other rights of SANYO Semiconductor Co.,Ltd. or any third party. SANYO Semiconductor Co.,Ltd. shall not be liable for any claim or suits with regard to a third party's intellectual property rights which has resulted from the use of the technical information and products mentioned above.

This catalog provides information as of December, 2007. Specifications and information herein are subject to change without notice.